

Transmitter equalization feedback and MDIO control

(In support of comment #i-9)

Adee Ran
Intel Corporation

Contributors:

- Pete Anslow
- Mike Dudek

Supporters:

- Rick Rabinovich

Clause 45 changes

(Further details in [anslow_01_062714_CAUI](#))

Current MDIO register definition

Table 45–71b—CAUI-4 chip-to-chip transmitter equalization, receive direction, lane 0 register bit definitions

Bit(s)	Name	Description	R/W ^a
1.180.15:5	Reserved	Value always 0, writes ignored	RO
1.180.4:2	Post-cursor setting	4 3 2 1 1 1 = Reserved 1 1 0 = Reserved 1 0 1 = -0.25 1 0 0 = -0.2 0 1 1 = -0.15 0 1 0 = -0.1 0 0 1 = -0.05 0 0 0 = 0	R/W
1.180.1:0	Pre-cursor setting	1 0 1 1 = -0.15 1 0 = -0.1 0 1 = -0.05 0 0 = 0	R/W

1
2
3
4
5
6
7
8
9
10
11
12
13
14
15
16
17
18
19
20

Modify and Extend this definition:

- In bits 4:0, rename “setting” to ”local setting”
- Change descriptions to refer to new variables *Local_eq_cm1* and *Local_eq_c1* (to be defined in annex 83D)
- Add new fields:
 - Bits 9:5, “remote setting”, variables *Remote_eq_cm1* and *Remote_eq_c1*, R/W
 - Bits 14:10, “request”, variables *Requested_eq_cm1* and *Requested_eq_c1*, RO
 - Bit 15, “request flag”, variable *Request_flag*, RO

Annex 83D changes

83D.1 Overview

- Change the sentence that starts in line 54 of page 151 as follows:

The CAUI-4 transmitter on each end of the link is adjusted to an appropriate setting based on channel knowledge. If implemented, the transmitter equalization feedback mechanism described in 83D.3.3.2 may be used to identify an appropriate setting. The adaptive or adjustable receiver performs the remainder of the equalization.

83D.3.1.1 Transmitter equalization settings

- Change text in 83D.3.1.1 as in the next slide
 - Add variables corresponding to the $c(-1)$ and $c(1)$ tap values
- Add columns to tables 83D-2 and 83D-3 defining the effect of variable values (per current descriptions in tables 45-71b and 45-71c)

Transmitter equalization settings

- Text before table 83D-2 in section 83D.3.1.1:

The variable *Local_eq_cm1* controls the pre-cursor tap value $c(-1)$. The valid values of *Local_eq_cm1* and their effect are specified in Table 83D-2. The variable *Local_eq_c1* controls the post-cursor tap value $c(1)$. The main tap value $c(0)$ is calculated from *Local_eq_cm1* and *Local_eq_c1* such that $c(0)=1+c(-1)+c(1)$. The valid values of *Local_eq_c1* and their effect are specified in Table 83D-3. *Local_eq_cm1* and *Local_eq_c1* are independent of each other, and independent on each lane.

- Change the second paragraph as follows:

If a Clause 45 MDIO is implemented, *Local_eq_cm1* and *Local_eq_c1* for each lane (0 through 3) and direction (transmit and receive) are accessible through registers 1.180 through 1.187 (see 45.2.1.92b through 45.2.1.92e).

Table 83D-2 – Pre-cursor equalization

Replace with the following table:

<i>Local_eq_cm1</i> value	c(-1) value	R_{pre} when <i>Local_eq_c1=0</i>
0	0	1 ±12.5%
1	-0.05	1.11 ±12.5%
2	-0.1	1.25 ±12.5%
3	-0.15	1.43 ±12.5%

Table 83D-3 – Post-cursor equalization

Replace with the following table:

<i>Local_eq_c1</i> value	c(1) value	R_{post} when <i>Local_eq_cm1=0</i>
0	0	1 ±12.5%
1	-0.05	1.11 ±12.5%
2	-0.1	1.25 ±12.5%
3	-0.15	1.43 ±12.5%
4	-0.2	1.67 ±12.5%
5	-0.25	2 ±12.5%

Transmitter equalization feedback (optional)

Insert new subclause 83D.3.3.2 after 83D.3.3.1 (Receiver interference tolerance) :

83D.3.3.2 Transmitter equalization feedback (optional)

Transmitter equalization feedback is an optional capability for a CAUI-4 chip-to-chip receiver. If implemented, it shall be as described in this subclause.

Transmitter equalization feedback is generated for each lane (0 through 3) and direction (transmit and receive) independently. The variables that control transmitter equalization feedback are specific for each lane and direction.

A CAUI-4 chip-to-chip receiver may generate a request to change the transmit equalization coefficients of the remote transmitter to new values by setting the *Request_flag* variable to 1. The variables *Requested_eq_cm1* and *Requested_eq_c1* indicate the requested values of *Local_eq_cm1* and *Local_eq_c1*, respectively, in the remote transmitter (see Table 83D-2 and Table 83D-3). The requested setting may be generated from the remote CAUI-4 chip-to-chip transmitter's equalization setting, which is stored in the variables *Remote_eq_cm1* and *Remote_eq_c1*, and from information internal to the receiver, in an implementation specific manner.

When a CAUI-4 chip-to-chip receiver does not request a change of the remote transmitter's transmit equalization setting, it sets the *Request_flag* variable to 0. A CAUI-4 chip-to-chip receiver that does not implement transmitter equalization feedback always sets *Request_flag* to 0.

If a Clause 45 MDIO is implemented, the variables *Request_flag*, *Requested_eq_cm1*, *Requested_eq_c1*, *Remote_eq_cm1* and *Remote_eq_c1* for each lane and direction are accessible through registers 1.180 through 1.187 (see 45.2.1.92b through 45.2.1.92e).

Example usage of the optional transmitter equalization feedback

Insert new subclause 83D.5:

83D.5 Example usage of the optional transmitter equalization feedback

83D.5.1 Overview

If implemented, transmitter equalization feedback from a CAUI-4 chip-to-chip receiver may be used to tune the equalization settings of the transmitter at the other end of the CAUI-4 chip-to-chip link to the values requested by the receiver. An example of a possible transmitter equalization tuning process using transmitter equalization feedback is provided in this subclause.

In this example, two components, A and B, are connected by a CAUI-4 chip-to-chip link, such that A is closest to the PCS and B is closest to the PMD. Clause 45 MDIO is implemented by both components, with component A at device address 11 and component B at device address 10. Transmitter equalization feedback is implemented by either component A, component B, or both. One Station Management (STA) controls both components.

Figure 83D-5 depicts the components of the CAUI-4 chip-to-chip link and the registers used during the tuning procedure.

(insert Figure 83D-5 here)

The STA performs the procedures described in 83D.5.2 and 83D.5.3 to tune lane 0 equalization settings in both sides of the CAUI-4 chip-to-chip link. When these procedures are completed, the STA uses similar procedures to tune equalization settings in lanes 1 through 3. When all lanes are tuned, the STA may repeat the process with another pair of components connected by CAUI-4 chip-to-chip.

NOTE – Using non-optimal transmitter equalization settings (or changing them) during the tuning procedure may interrupt data communication. The CAUI-4 bit error ratio is assumed to meet the requirements of 83D.3.3.1 upon completion of the tuning process.

Example procedure for tuning equalization settings on lane 0, Transmit direction

83D.5.2 Tuning equalization settings on lane 0 in the Transmit direction

1. Read Local_eq_cm1 (11.184.1:0) and Local_eq_c1 (11.184.4:2) from component A.
2. Write Local_eq_cm1 and Local_eq_c1 read from component A to Remote_eq_cm1 (10.184.6:5) and Remote_eq_c1 (10.184.9:7), respectively, in component B.
3. Read Request_flag (10.184.15), Requested_eq_cm1 (10.184.11:10) and Requested_eq_c1 (10.184.14:12) from component B.
4. If Request_flag is 0, go to tuning equalization settings on lane 0 in the Receive direction (83D.5.3)
5. If Request_flag is 1, write Requested_eq_cm1 and Requested_eq_c1 read from component B to Local_eq_cm1 (11.184.1:0) and Local_eq_c1 (11.184.4:2), respectively, in component A.
6. Go to step 1.

Example procedure for tuning equalization settings on lane 0, Receive direction

83D.5.3 Tuning equalization settings on lane 0 in the Receive direction

1. Read Local_eq_cm1 (10.180.1:0) and Local_eq_c1 (10.180.4:2) from component B.
2. Write Local_eq_cm1 and Local_eq_c1 read from component B to Remote_eq_cm1 (11.180.6:5) and Remote_eq_c1 (11.180.9:7), respectively, in component A.
3. Read Request_flag (11.180.15), Requested_eq_cm1 (11.180.11:10) and Requested_eq_c1 (11.180.14:12) from component A.
4. If Request_flag is 0, proceed to tuning lane 1.
5. If Request_flag is 1, write Requested_eq_cm1 and Requested_eq_c1 read from component A to Local_eq_cm1 (10.180.1:0) and Local_eq_c1 (10.180.4:2), respectively, in component B.
6. Go to step 1.

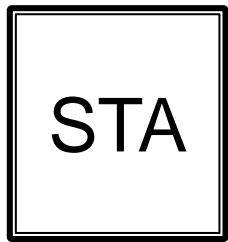

PCS (Transmit direction)

PCS (Receive direction)

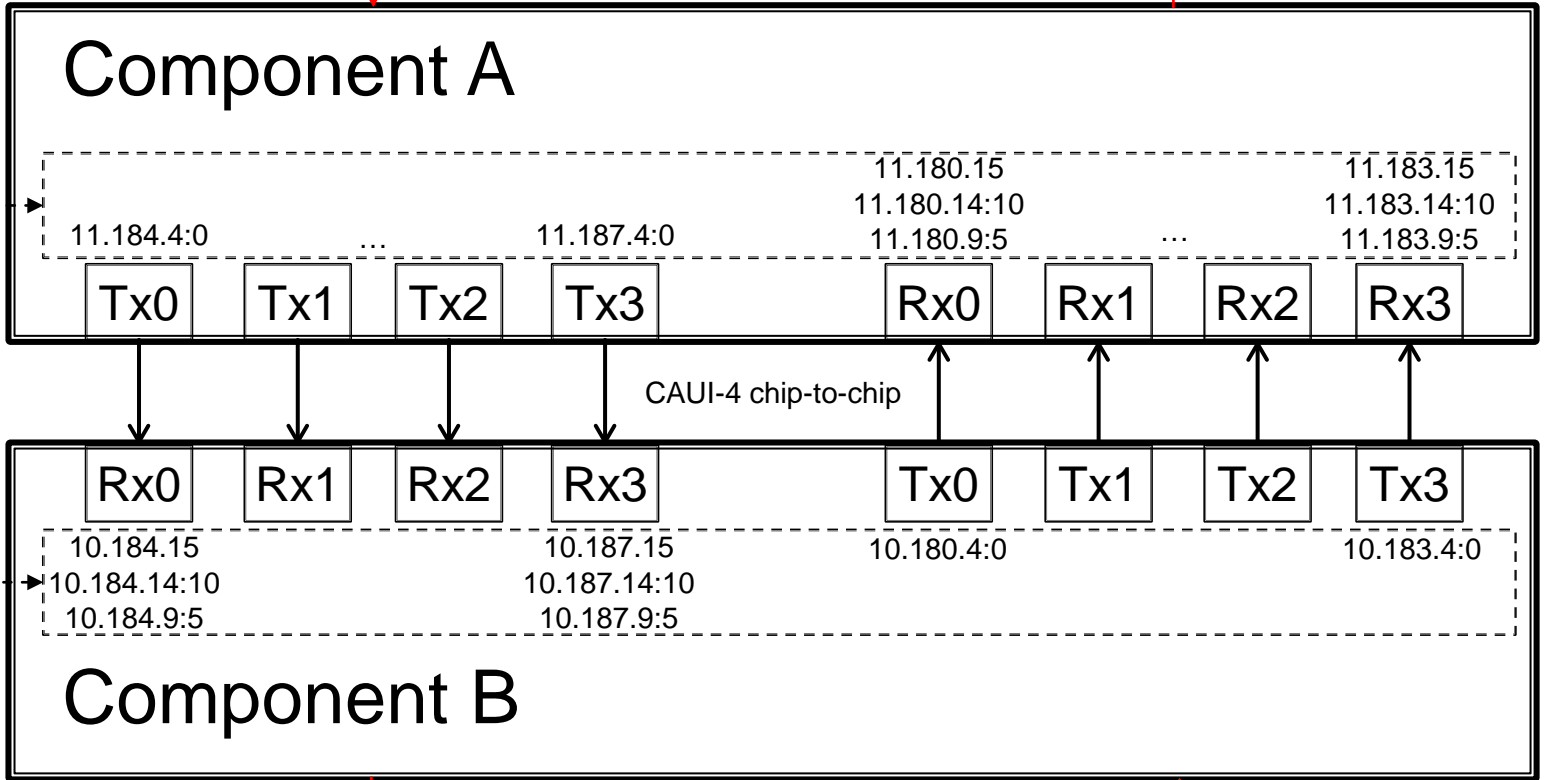

PMD (Transmit direction)

PMD (Receive direction)