

100m MMF reach objective baseline proposal

14th January 2013

MMF ad hoc

Outline

- Baseline proposal of a retimed PMD to address 802.3bm objective to ‘Define a 100 Gb/s PHY for operation up to at least 100 m of MMF’
 - 4 lane parallel, short wavelength based PMD for 100GBASE-SR4
 - >100m reach is enabled by making use of the KR4 FEC defined in 802.3bj
 - Architecture, parameters and specifications for optical interfaces follow

Supporters and contributors

- Pete Anslow, Ciena
- Gary Bernstein, Leviton
- Chris Cole, Finisar
- Doug Coleman, Corning
- Mike Dudek, QLogic
- Jonathan King, Finisar
- Paul Kolesar, Commscope
- Ryan Latchman, Mindspeed
- Sharon Lutz, US Conec
- Phil McClay, TE Connectivity
- Gary Nicholl, Cisco
- Mark Nowell, Cisco
- John Petrilla, Avago Technologies
- Petar Pepeljugoski, IBM
- Rick Rabinovich, Alcatel-Lucent
- Nathan Tracy, TE Connectivity
- Greg LeCheminant, Agilent
- Mike Peng Li, Altera
- Steve Swanson, Corning
- CK Wong, FCI

Motivation

- 4 parallel links operating at 25.78125 GBd utilize low cost, high performing multimode fiber compatible optics and electronics
 - FEC supported retimed interface enables a lowest power, lowest cost, 100m solution today
 - Uses existing, viable semiconductor technologies
 - Compatible with uncooled VCSEL
- The 4 optical lanes directly map the 4 electrical lanes, without requiring multiplexing, translation, or de-skewing inside the module
- This proposal is supported by multiple vendors and users, and is economically feasible and competitive compared to other alternatives

Proposal

- 4 parallel lanes @ 25.78125 GBd for 100GBASE-SR4 over OM4 fiber
- 850 nm sources
- Uses 100GBASE-KR4 FEC being defined in 802.3bj

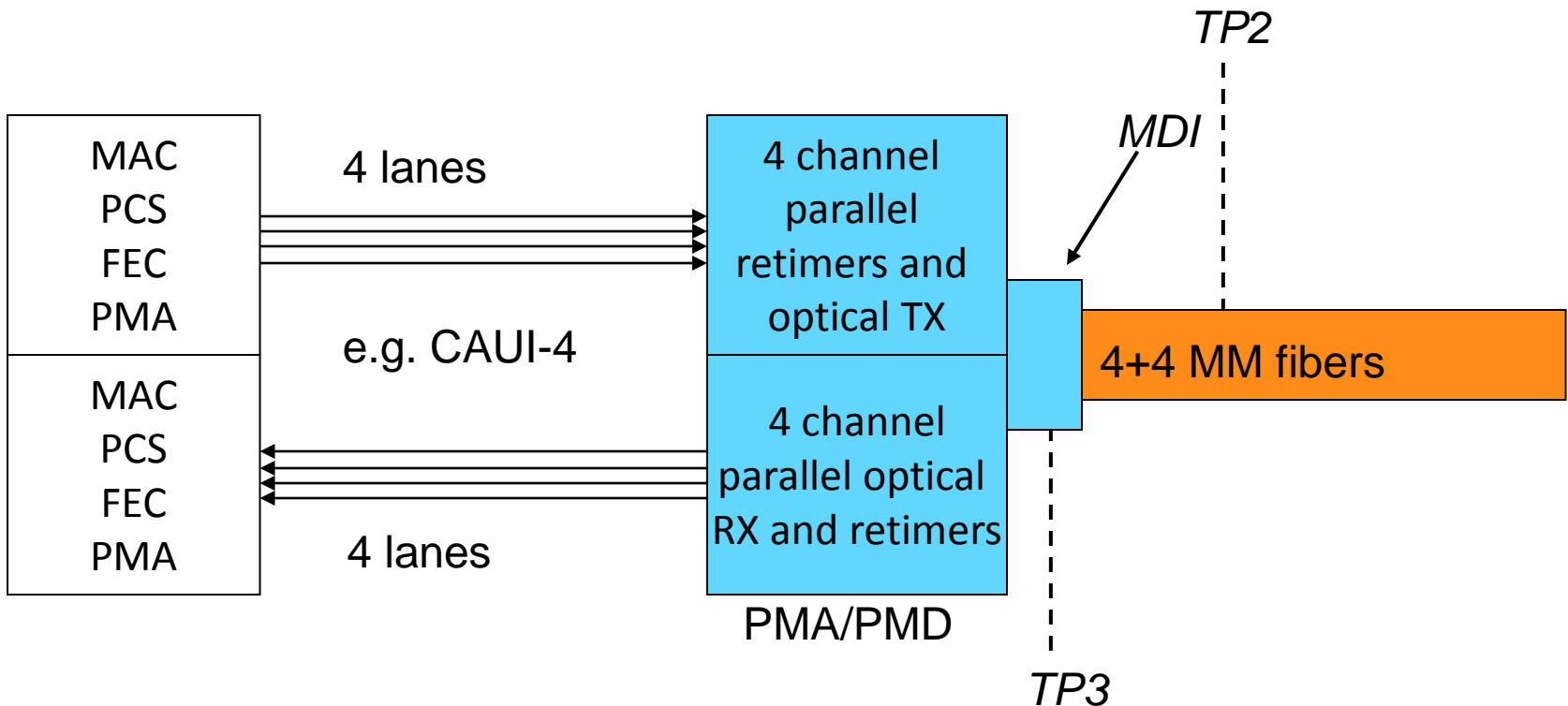

Position in 802.3 architecture

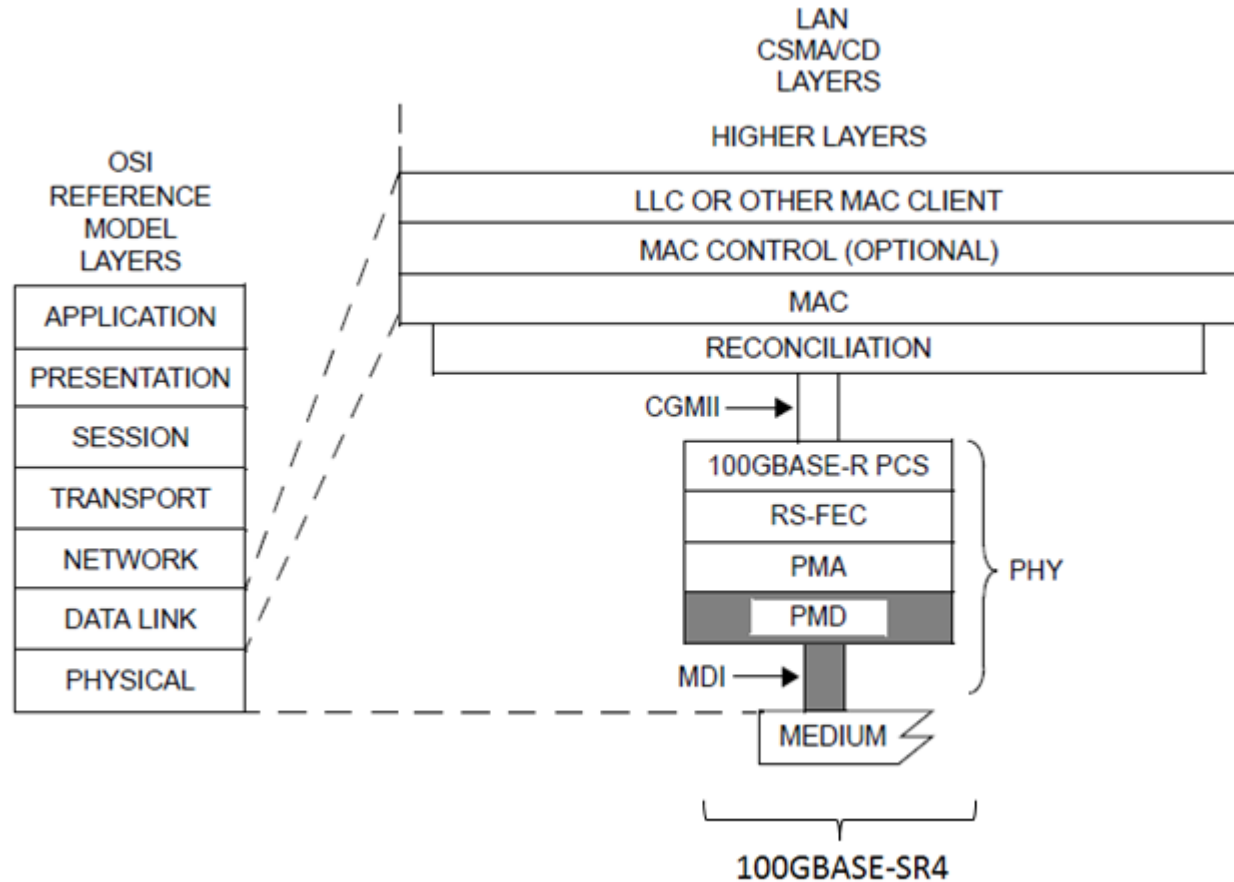

CGMII = 100 Gb/s MEDIA INDEPENDENT INTERFACE
 LLC = LOGICAL LINK CONTROL
 MAC = MEDIA ACCESS CONTROL
 MDI = MEDIUM DEPENDENT INTERFACE

PCS = PHYSICAL CODING SUBLAYER
 PHY = PHYSICAL LAYER DEVICE
 PMA = PHYSICAL MEDIUM ATTACHMENT
 PMD = PHYSICAL MEDIUM DEPENDENT
 RS-FEC = REED-SOLOMON FORWARD ERROR CORRECTION

Block diagram

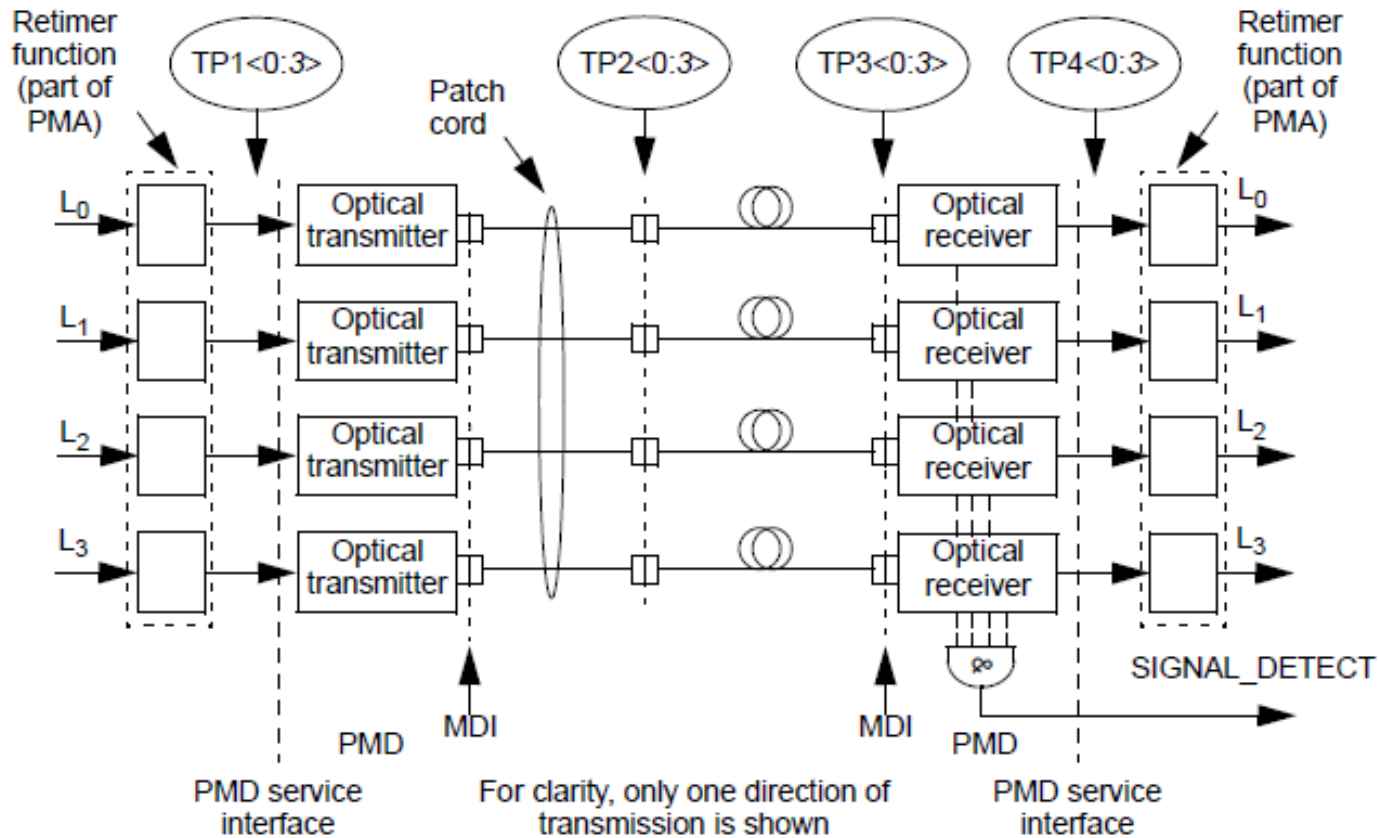

- TP1 and TP4, shown here for illustration only, represent the start and end of link budget calculations. They may not be accessible points for measurements, nor are they intended as reference points for specifications

Transmitter characteristics (each lane)

Description	Type	Unit	Strawman
Signal rate		GBd	25.78125 ±100ppm
Center wavelength	range	nm	840 to 860
RMS spectral width	max	nm	0.6
Average launch power	max	dBm	2.4
Average launch power	min	dBm	-9.1 (tbc)*
Optical Modulation Amplitude (OMA)	max	dBm	3
OMA	min	dBm	-7.1 (tbc) ^{a,*}
OMA at max TDP	min	dBm	-3
Launch power in OMA minus TDP	min	dBm	-8 (tbc)*
Difference in launch power between any two lanes (OMA)	max	dB	ffs (4 or greater)
Transmitter & dispersion penalty (TDP) at target BER before FEC	max	dB	5 (tbc)*
Extinction ratio	min	dB	3
Optical return loss tolerance	max	dB	12
Encircled Flux			≥ 86% @ 19um, ≤ 30% at 4.5um
Transmitter eye mask definition {X1, X2, X3, Y1, Y2, Y3}, 5×10 ⁻⁵ hits/sample			ffs
Average launch power of OFF transmitter	max	dBm	-30

^a Even if the TDP is less than 0.9 dB the OMA min must exceed this value

*TDP value and dependent parameters are subject to confirmation

Receiver characteristics (each lane)

Description	Type	Unit	Strawman
Signal rate		GBd	25.78125 ±100ppm
Center wavelength	range	nm	840 to 860
Damage threshold	min	dB	3.4
Average power at receiver	max	dBm	2.4
Average power at receiver	min	dBm	-11.0 (tbc)*
Optical Modulation Amplitude (OMA)	max	dBm	3
Stressed receiver sensitivity in OMA	max	dBm	ffs
SRS test conditions			ffs
Receiver reflectance		dB	-12

*TDP value and dependent parameters are subject to confirmation

Link and Cable Characteristic

Parameter	Type	Unit	Value
Supported fiber types			50μm OM4, (OM3 ²)
Effective Modal Bandwidth		MHz*km	4700 ¹ , (2000 ^{1,2})
Power Budget	min	dB	8.2
Operating Range		m	0.5 to 106 ²
Channel insertion loss	max	dB	1.9

Note 1: With EMB as specified in clause 86

Note 2: Reach on OM4; equivalent reach on OM3 is for further study in the task force

Further Work

- Fine tune parameters/eliminate TBDs and items for further study
 - Some TBD/ffs items may be present in first draft
- Compliance tests development
- Reach for OM3