

100G PSM4 Link Model & Results Update

John Petrilla: Avago Technologies

May 2013

100G PSM4 Link Model & Results Update

Presentation Objectives:

- Update set of attribute values for 100G PSM4, 500 m SMF, example link model
- Provide comparison with link models attributes for 10GBASE-LR and 100GBASE-LR4
- Provide comparison between 10GBASE-LR and 100G PSM4 for sensitivity to optical reflection penalties
- Provide comparison between 10GbE link model and MPI Upper Bound estimates of reflection penalties

Conclusions:

- The 10GbE based example link model sufficiently addresses adverse effects of MPI.

Fiber Optic Links Interfaces

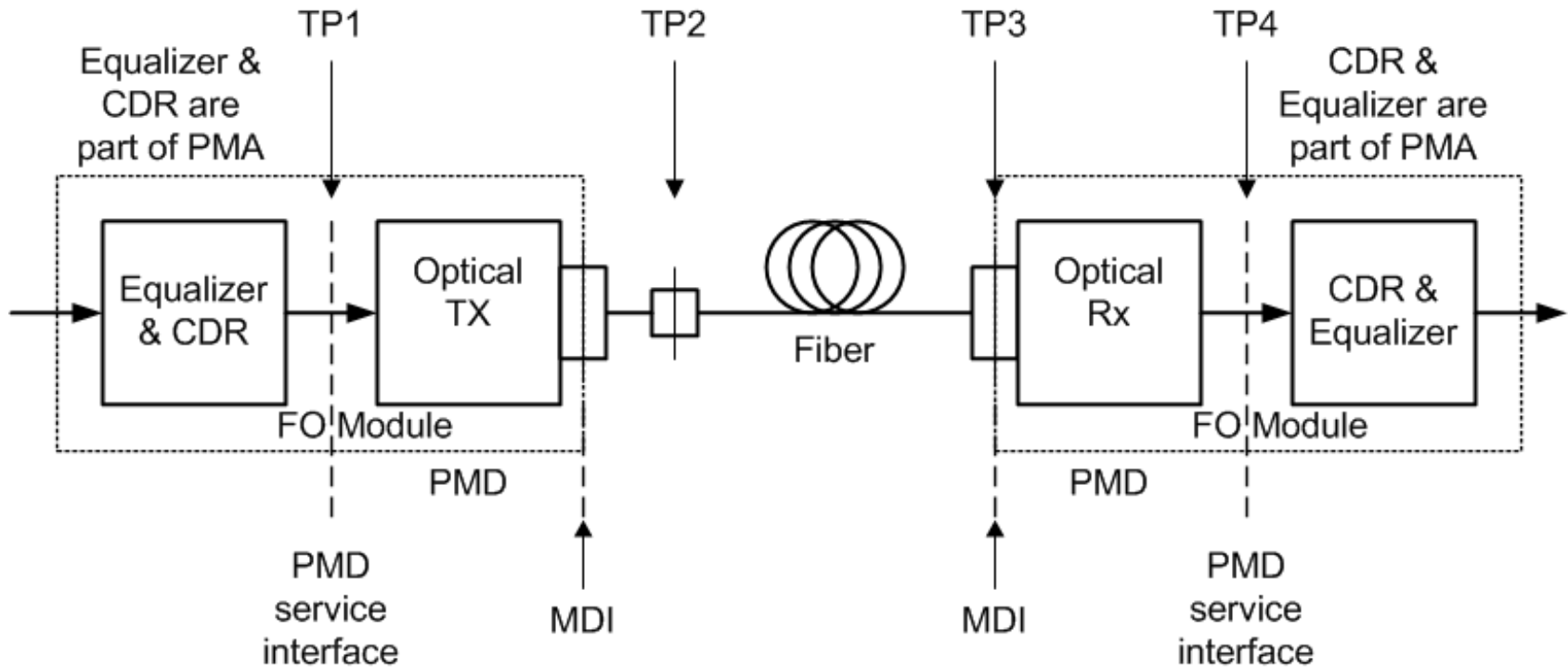

Figure 1

- For cases, as shown above in Figure 1, where retimers are incorporated in the optical module, the PMD service interface is not exposed. TP1 and TP4 remain as points on the PMD service interface and, consequently not exposed.
- The high speed signal inputs and outputs of the optical module are expected to be defined by CAUI-4.

100G PSM4 with KR4 FEC: Tx Link Model Attributes (each lane)

Parameter	Unit	10G LR	100G LR4	100G PSM4	
Signal rate	GBd	10.3125	25.78125		
Q (BER)		7.034 (E-12)		3.8905 (5E-5)	KR4 FEC corrects PSM4 BER to $\leq E-12$
Center Wavelength, min	nm	1260	1294.53	1295	
Center Wavelength Range, max	nm	95	2.1	30	
Spectral Width, max	nm	0.20			Note 1
OMA at max TDP & w.l. offset, min	dBm	-3.0	-0.1	-2.6	Note 2
Extinction ratio, min	dB	3.5	4.0	3.5	
Tx output transition times, 20% -80%, max	ps	47	12	16	
RINcOMA, max	dB/Hz	-128	-130	-130	Note 3
RIN coefficient		0.7			
Tx reflectance, max	dB	-12			
Tx optical return loss tolerance, max	dB	12	20	12	

Attributes and values in the above table are provided in order to populate example link models and may not be normative.

Note 1, Model uses 0.2 nm spectral width to generate penalty equivalent to max expected from chirp.

Note 2, Trade-offs are available for 100G PSM4 with min OMA, center wavelength and TDP.

Note 3, For 10G LR & 100G PSM4, $c = 12$ and for 100G LR4, $c = 20$.

100G PSM4 with KR4 FEC: Rx Link Model Attributes (each lane)

Parameter	Unit	10G LR	100G LR4	100G PSM4	
Signal rate	GBd	10.3125	25.78125		
Q (BER)		7.034 (E-12)		3.8905 (5E-5)	KR4 FEC corrects PSM4 BER to \leq E-12
Center Wavelength, min	nm	1260	1294.53	1295	
Center Wavelength Range, max	nm	95	2.1	30	
Rx sensitivity (OMA), max	dBm	-12.6	-8.6	-9.67 (-7.10 at Q = 7.034)	
Rx Bandwidth, min	MHz	7734	19,336		
RMS base line wander coefficient	dB/Hz	0.025			
Rx reflectance, max	dB	-12	-26	-7.94	Note 1

Attributes and values in the above table are provided in order to populate example link models and may not be normative attributes.

Note 1, 100G PSM4 Rx reflectance is a single point equivalence for a -12 dB Rx reflectance and four inline connectors each at **-35 dB** reflectance. The single point equivalence was determined with the Upper Bound penalty calculation in “PAM MPI – Overview & Recommendations”, http://www.ieee802.org/3/100GNGOPTX/public/may12/bhatt_01_0512_optx.pdf

100G PSM4 with KR4 FEC: Link Model Channel Attributes (each lane)

Parameter	Unit	10G LR	100G LR4	100G PSM4	
Signal rate	GBd	10.3125	25.78125		
Q (BER)		7.034 (E-12)		3.8905 (5E-5)	KR4 FEC corrects PSM4 BER to $\leq E-12$
Reach	km	10	10	0.5	
Fiber Attenuation	dB/km	0.40	0.424	0.50	For 1310 nm center wavelength
Dispersion, min Uo	nm	1324			
Dispersion, So	ps/nm ² km	0.093			
PoIMD DGD max	ps	10	10	2.24	Sq root dependency with length
Reflection Noise Factor		0.6			
Signal power budget at max TDP	dB	9.6	8.50	7.07	Model output
Connector & splice loss allocation	dB	2.0	2.0	3.0	
Fiber Insertion loss	dB	4.20	4.30	0.25	Model output
Allocation for penalties at max TDP	dB	3.26	1.93	3.82	Model output, includes Peye
Additional insertion loss allowed	dB	0.0	0.0	0.0	Model output

Attributes and values in the above table are provided in order to populate example link models and may not be normative attributes. Various model outputs are provided.

100G PSM4 with KR4 FEC: Link Model Jitter Attributes (each lane)

Parameter	Unit	10G LR	100G LR4	100G PSM4	
Signal rate	GBd	10.3125	25.78125		
Q (BER)		7.034 (E-12)		3.8905 (5E-5)	KR4 FEC corrects PSM4 BER to \leq E-12
TP1 RJrms tolerance, min	UI	0.0036	0.0054	0.0079	
TP1 DJ tolerance, min	UI	0.083	0.087	0.110	
TP3 DCD tolerance, min	UI	0.0619	0.05	0.050	
TP3 DJ tolerance, min	UI	0.083	0.087	0.163	
TP4 J2, max	UI	0.376	0.359	0.568	Model output
TP4 TJ at BER, max	UI	0.900	0.850	0.780	Model output

Attributes and values in the above table are provided in order to populate example link models and may not be normative attributes. Various model outputs are provided.

Nomenclature: Terms TP1, TP2, TP3 and TP4 are used as defined in 802.3 clause 88 and shown in above Figure 1. Note that TP1 is downstream of the input CDR and equalizer for an optical transmitter.

Reflection Penalties: Low Loss Cases

Case	Reach	Channel IL	Tx Refl	Rx Refl	In Line Refl	ER	Link Model Margin (Refl NF = 0.6)	Link model total penalty for Reflections Note 1	Upper Bound Penalty
10G LR	2 m	0	12	12	100	3.5	3.36	4.10	2.65
100G PSM4	2 m	0	12	12	100	3.5	2.47	2.60	2.65
10G LR	500 m	0.21	12	12	100	3.5	3.53	3.71	2.48
100G PSM4	500 m	0.25	12	12	100	3.5	2.38	2.41	2.48
10G LR	500 m	0.21	12	12	55	3.5	3.07	4.17	2.67
100G PSM4	500 m	0.25	12	12	55	3.5	2.18	2.61	2.67
10G LR	500 m	0.21	12	12	35	3.5	Off scale	Off scale	5.14
100G PSM4	500 m	0.25	12	12	35	3.5	-0.76	5.55	5.14

Note 1, The link model total penalty for reflections is determined by the difference in link margin between the cases where the Reflection noise factor is set to 0.0 and where it is set to 0.60.

- Penalties using the MPI Upper-Bound penalty from bhatt_01_0512 (http://www.ieee802.org/3/100GNGOPTX/public/may12/bhatt_01_0512_optx.pdf) are compared in the above table with penalties from the example link model for various case of 10G LR and 100G PSM4.
- For the Bhatt Upper-Bound penalty calculations, PAM2, four inline connectors in addition to the connectors at the module interface are assumed. Independent variables are: channel insertion loss, return loss of the module connectors, return loss of the inline connectors and ER.
- Since the example link model does not accommodate inline connectors, for the < 100 dB inline connector cases, Tx Refl and Rx Refl values (not shown above) were adjusted to provide an equivalence using the Bhatt Upper-Bound penalty calculations.
- For the low loss cases in the above table, it can be seen that the example link model estimates comparable or higher penalties than the Bhatt Upper-Bound penalty calculations. Also, 100G PSM4 always shows positive margin except for a case where the inline connectors have a 35 dB ORL and zero insertion loss. 100G PSM4 tolerates this case better than 10G LR.

Reflection Penalties: 500 m Cases

Case	Reach	Channel IL	Tx Refl	Rx Refl	In Line Refl	ER	Link Model Margin (Refl NF = 0.6)	Link model total penalty for Reflections Note 1	Upper Bound Penalty
10G LR	500 m	2.21	12	12	100	3.5	3.44	1.80	1.39
100G PSM4	500 m	2.25	12	12	100	3.5	0.94	1.33	1.39
10G LR	500 m	2.21	12	12	55	3.5	3.30	1.94	1.49
100G PSM4	500 m	2.25	12	12	55	3.5	1.36	1.43	1.49
10G LR	500 m	2.21	12	12	35	3.5	1.48	3.76	2.50
100G PSM4	500 m	2.25	12	12	35	3.5	0.36	2.43	2.50
10G LR	500 m	3.21	12	12	100	3.5	2.90	1.34	1.07
100G PSM4	500 m	3.25	12	12	100	3.5	0.88	1.02	1.07
10G LR	500 m	3.21	12	12	55	3.5	2.81	1.43	1.14
100G PSM4	500 m	3.25	12	12	55	3.5	0.70	1.09	1.14
10G LR	500 m	3.21	12	12	35	3.5	1.72	2.52	1.86
100G PSM4	500 m	3.25	12	12	35	3.5	0.0	1.79	1.86

Note 1, The link model total penalty for reflections is determined by the difference in link margin between the cases where the Reflection noise factor is set to 0.0 and where it is set to 0.60.

- For the 500 m cases in the above table, as with the low loss cases, the example link model estimates comparable or higher penalties than the Bhatt Upper-Bound penalty calculations.

- The conservatism of the worst case based 10GbE link model appears to adequately address adverse MPI effects.

Reflection Penalties: High Loss Cases

Case	Reach	Channel IL	Tx Refl	Rx Refl	In Line Refl	ER	Link Model Margin (Refl NF = 0.6)	Link model total penalty for Reflections Note 1	Upper Bound Penalty
10G LR	2 km	2.84	12	12	100	3.5	3.08	1.50	1.18
10G LR	2 km	2.84	12	12	55	3.5	2.97	1.61	1.25
10G LR	2 km	2.84	12	12	35	3.5	1.66	2.92	2.07
10G LR	2 km	2.84	12	12	26	3.5	Off scale	Off scale	4.85
10G LR	2 km	3.84	12	12	100	3.5	2.45	1.13	0.91
10G LR	2 km	3.84	12	12	55	3.5	2.37	1.21	0.96
10G LR	2 km	3.84	12	12	35	3.5	1.53	2.06	1.55
10G LR	2 km	3.84	12	12	26	3.5	-3.11	6.70	3.32
10G LR	10 km	6.20	12	12	100	3.5	0.0	0.70	0.50
10G LR	10 km	6.20	12	12	55	3.5	-0.05	0.75	0.53
10G LR	10 km	6.20	12	12	35	3.5	-0.50	1.20	0.83
10G LR	10 km	6.20	12	12	26	3.5	-1.90	2.60	1.61

Note 1, The link model total penalty for reflections is determined by the difference in link margin between the cases where the Reflection noise factor is set to 0.0 and where it is set to 0.60.

- For the high loss cases in the above table, as with the low loss and 500 m cases, the example link model estimates higher penalties than the Bhatt Upper-Bound penalty calculations.

- The conservatism of the worst case based 10GbE link model appears to adequately address adverse MPI effects.

Link Model Background (1 of 2)

Link Model Update

Piers Dawe
Vipul Bhatt

Los Angeles, October 2001

Reflection Noise (Interferometric Noise)

- Formula is intended to follow Krister Fröjd, Petar Pepeljugoski and their colleagues
- Because the noise is bounded and may be concentrated at extremes, it is calculated like a source of ISI not random noise
- Reflection noise factor of 0.6 introduced to avoid undue pessimism
 - *The value (0.6) needs further consideration*

Los Angeles, Oct. 2000

Link Model Update

8

To provide background, pages are copied from the “Link Model Update”, http://www.ieee802.org/3/ae/public/oct01/dawe_1_1001.pdf where the reflection noise penalty was introduced into the 10GbE link model and shown here and on the following page. The reflection noise penalty is calculated (in dB) according to the following expression

$$P_r = -10 \cdot \log \left[1 - \frac{2 \cdot R_{NF} \cdot 10^{\frac{-ChL}{10}} \cdot GMR \cdot \sqrt{1 + \epsilon + 2 \cdot \epsilon \cdot O(DJ_{eff}) \cdot (\epsilon - 1)}}{O(DJ_{eff}) \cdot (\epsilon - 1)} \right] \quad (27)$$

and can also be found in, “ONIDS 2002 Review of the 10Gigabit Ethernet Link Model”, David Cunningham & Piers Dawe at <http://www.avagotech.com/docs/AV02-2485EN>

Prior to dawe_1_1001, there were 6 contributions commenting on the need for a reflection noise penalty. Afterwards there were none.

Model vs. reality

- Model appears to be pessimistic by ~1-2 dB
 - Reason is not known
 - Could be that receivers are better than we thought (always some transmitter penalty even with test equipment)
 - A zero or slightly negative penalty output from the model may be acceptable
- Jitter measurements are inaccurate and not easily corrected by calibration. Big problem.
- Model does not include RJ
 - Assume most RJ is already accounted for as noise in amplitude domain
- The dispersion penalty calculation was meant for multimode lasers, is likely to be inaccurate for **single mode lasers**

Los Angeles, Oct. 2000

Link Model Update

18

- The 10GbE link model has been a valuable tool for over 10 years.
- 10G LR, based on the 10GbE model has been shipping for ~ 10 years with good results.
- Does anyone believe the definition of 10G LR is broken?
- There have been 156 Maintenance Requests submitted since Oct. 2001. None were related to 10GBASE-LR.
- Recommendation: Continue to use a Reflection Noise factor value of 0.6 in 10GbE based link models.