

# **100G MMF: 70m OM3 & 100m OM4 Link Model Comparison**

John Petrilla: Avago Technologies

May 2013

# 100G MMF: 70 m OM3 & 100 m OM4 Link Model Comparison

## Presentation Objectives:

Provide values for 100G MMF Example Link Model cases and 100GBASE-SR4 draft baseline

- 100 m OM4
- 70 m OM3

## Link Model Reference

<http://www.avagotech.com/docs/AV02-2485EN>

# Fiber Optic Links Interfaces

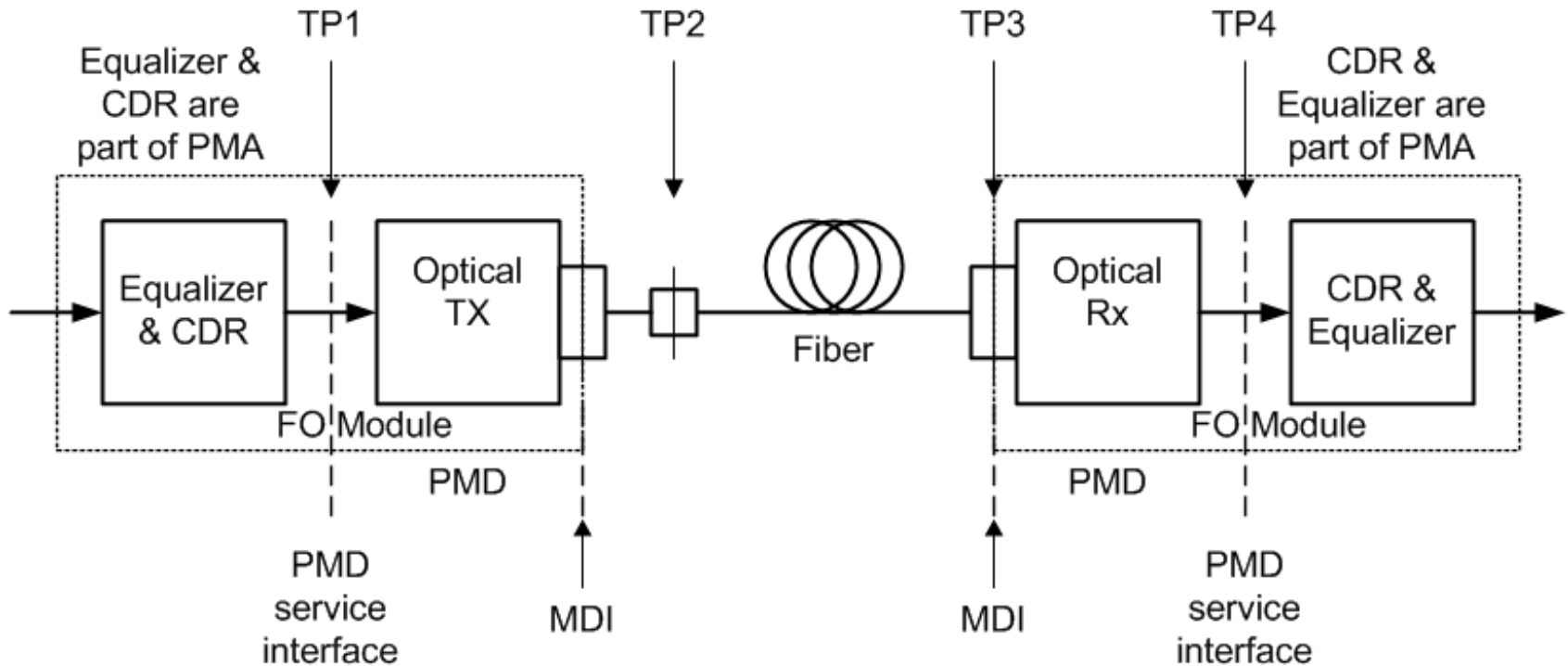

Figure 1

- For cases, as shown above in Figure 1, where retimers are embedded in the optical module, the PMD service interface is not exposed. TP1 and TP4 remain as points on the PMD service interface and, consequently, not exposed.
- The high speed signal inputs and outputs of these optical modules are expected to be defined by CAUI-4.

# 100G SR4 with KR4 FEC: Example Link Model Tx Attributes (each lane)

Parameter/Case	Unit	100 m OM4	70 m OM3	
Signal rate	GBd	25.78125	25.78125	
Q (BER)		3.8905 (5.0E-5)	3.8905 (5.0E-5)	FEC corrects BER to $< 10^{-12}$
Center Wavelength, min	nm	840	840	
Spectral Width, max	nm	0.60	0.60	
OMA at max TDP, min	dBm	-3.0	-3.0	
Extinction ratio, min	dB	3.0	3.0	
Tx output transition times, 20% -80%, max	ps	21	21	
RIN <sub>12</sub> OMA, max	dB/Hz	-128	-128	
RIN coefficient		0.7	0.7	
MPN coefficient		0.3	0.3	
Modal Noise Penalty	dB	0.129	0.129	Scaled with Q
Tx reflectance, max	dB	-12	-12	
Tx optical return loss tolerance, max	dB	12	12	

Attributes and values in the above table are provided in order to populate example link models and may not be normative attributes.

# 100G SR4 with KR4 FEC: Rx Link Model Attributes (each lane)

Parameter/Case	Unit	100 m OM4	70 m OM3	
Signal rate	GBd	25.78125	25.78125	
Q (BER)		3.8905 (5.0E-5)	3.8905 (5.0E-5)	FEC corrects BER to $< 10^{-12}$
Wavelength, min	nm	840	840	
Rx sensitivity (OMA), max	dBm	-11.2	-11.2	-8.63 dBm at Q = 7.034
Rx Bandwidth, min	MHz	18,047	18,047	
RMS base line wander coefficient		0.025	0.025	
Rx reflectance, max	dB	-12	-12	

Attributes and values in the above table are provided in order to populate example link models and may not be normative attributes.

# 100G SR4 with KR4 FEC: Example Link Model Ch Attributes (each lane)

Parameter/Case	Unit	100 m OM4	70 m OM3	
Signal rate	GBd	25.78125	25.78125	
Q (BER)		3.8905 (5.0E-5)	3.8905 (5.0E-5)	FEC corrects BER to < 10 <sup>-12</sup>
Reach	m	100	70	
Fiber Attenuation	dB/km	3.5	3.5	For 850 nm center wavelength
Dispersion min Uo	nm	1316	1316	
Dispersion So	ps/nm <sup>2</sup> km	0.10275	0.10275	
Fiber modal bandwidth	MHz·km	4400	2000	For 840 nm center wavelength
Reflection Noise Factor		0	0	
Signal power budget at max TDP	dB	8.20	8.20	Model output
Connector & splice loss allocation	dB	1.50	1.50	
Fiber Insertion loss	dB	0.36	0.25	Model output
Allocation for penalties at max TDP	dB	6.34	6.28	Model output (includes Peye)
Unallocated Margin	dB	0	0.17	Model output

Attributes and values in the above table are provided in order to populate example link models and may not be normative attributes. Various model outputs are provided.

# 100G SR4 with KR4 FEC: Example Link Model Jitter Attributes (each lane)

Parameter/Case	Unit	100 m OM4	70 m OM3	
Signal rate	GBd	25.78125	25.78125	
Q (BER)		3.8905 (5.00E-5)	3.8905 (5.00E-5)	FEC corrects BER to $< 10^{-12}$
TP1 RJrms tolerance, min	UI	0.0079	0.0079	
TP1 DJ tolerance, min	UI	0.11	0.11	
TP3 DCD tolerance, min	UI	0.05	0.05	
TP3 DJ tolerance, min	UI	0.247	0.247	Model output
Cum DJ at TP4	UI	0.328	0.328	Model output
TP4 J2, max	UI	0.592	0.592	Model output
TP4 TJ at BER, max	UI	0.780	0.780	Model output

Attributes and values in the above table are provided in order to populate example link models and may not be normative attributes. Various model outputs are provided.

Nomenclature: Terms TP1, TP2, TP3 and TP4 are used as defined in 802.3 clause 86 and shown in above Figure 1. Note that TP1 is downstream of the input CDR and equalizer for an optical transmitter.