

# **100G SR4 Link Model Update, TDP, Tx Eye Mask & SRS**

John Petrilla: Avago Technologies

June 2013

# Presentation Summary

## Presentation Objectives:

- Provide an update of the example link model for 100G 100m MMF
- Propose updated example link model as a worst case link model for 100GBASE-SR4
- Present TDP setup and requirements for 100G 100m MMF Tx
- Present Tx Eye Mask setup & coordinates
- Present SRS setup & conditions – introduce SRS eye mask

## Link Model Reference

<http://www.avagotech.com/docs/AV02-2485EN>

# Fiber Optic Links Interfaces

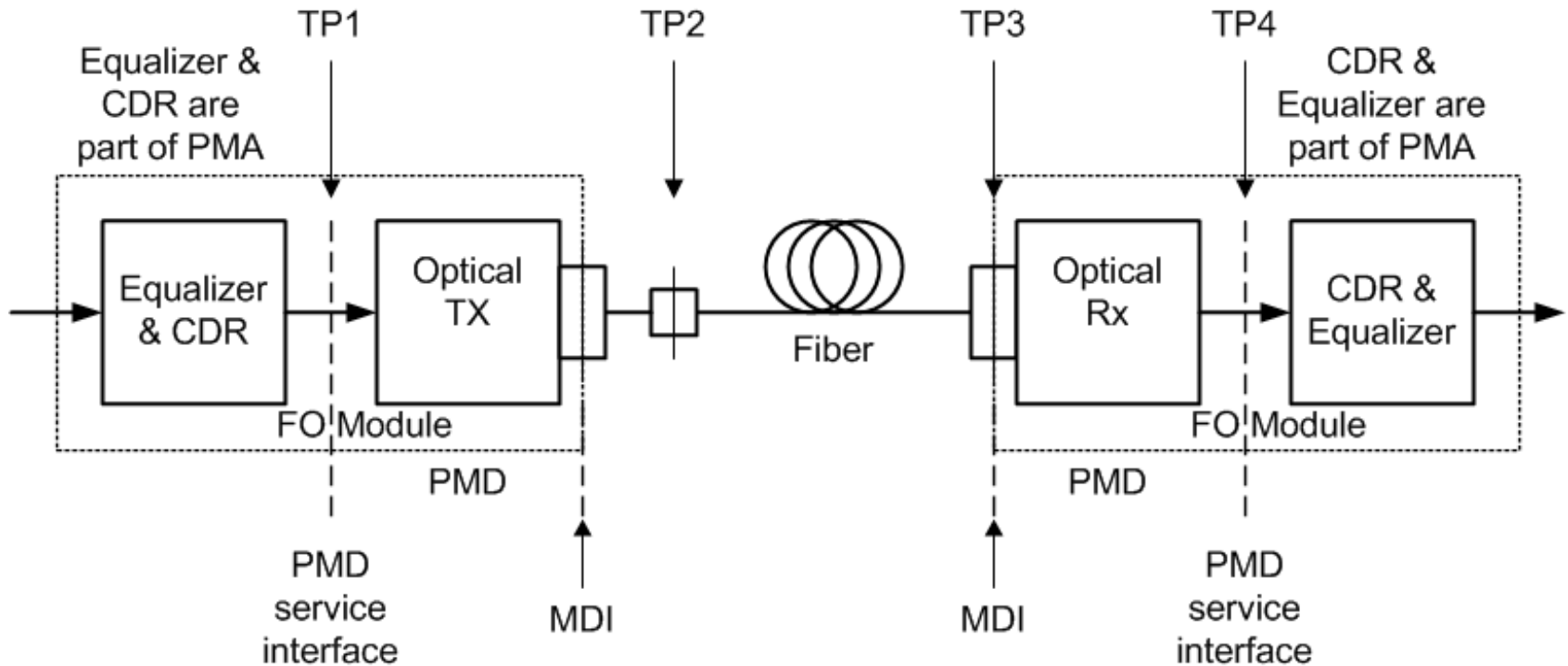

Figure 1

- For cases, as shown above in Figure 1, where retimers are embedded in the optical module, the PMD service interface is not exposed. TP1 and TP4 remain as points on the PMD service interface and, consequently, not exposed.
- The high speed signal inputs and outputs of the optical module are expected to be defined by CAUI-4.

# 100G SR4 with KR4 FEC: Example Link Model Tx Attributes (each lane)

Parameter	Unit	100G SR4	
Signal rate	GBd	25.78125	
Q (BER)		3.8905 (5.0E-5)	FEC corrects BER to < 1.0E-12
Center Wavelength, min	nm	840	
Spectral Width, max	nm	0.60	
OMA at max TDP, min	dBm	-3.0	
Extinction ratio, min	dB	3.0	Previously 4.0
Tx output transition times, 20% -80%, max	ps	21	
RIN <sub>12</sub> OMA, max	dB/Hz	-128	
RIN coefficient		0.7	
MPN coefficient		0.3	
Modal Noise Penalty	dB	0.129	Scaled with Q
Tx reflectance, max	dB	-12	
Tx optical return loss tolerance, max	dB	12	

Attributes and values in the above table are provided in order to populate example link models and are not presented as specification recommendations.

# 100G SR4 with KR4 FEC: Example Link Model Rx Attributes (each lane)

Parameter	Unit	100G SR4	
Signal rate	GBd	25.78125	
Q (BER)		3.8905 (5.0E-5)	FEC corrects BER to < 1.0E-12
Center Wavelength, min	nm	840	
Rx sensitivity (OMA), max	dBm	-11.2	-8.33 dBm at Q = 7.034
Rx Bandwidth, min	MHz	18,047	
RMS base line wander coefficient		0.025	
Rx reflectance, max	dB	-12	

Attributes and values in the above table are provided in order to populate example link models and are not presented as specification recommendations.

# 100G SR4 with KR4 FEC: Example Link Model Ch Attributes (each lane)

Parameter	Unit	100G SR4	
Signal rate	GBd	25.78125	
Q (BER)		3.8905 (5.0E-5)	FEC corrects BER to < 1.0E-12
Reach	m	100	<a href="#">Previously 106</a>
Fiber Attenuation	dB/km	3.5	For 850 nm center wavelength
Dispersion min Uo	nm	1316	
Dispersion So	ps/nm <sup>2</sup> km	0.10275	
Fiber modal bandwidth	MHz·km	4400	<a href="#">For 840 nm center wavelength, 4700 MHz·km at 850 nm</a>
Reflection Noise Factor		0	
Signal power budget at max TDP	dB	8.20	Model output
Connector & splice loss allocation	dB	1.50	
Fiber Insertion loss	dB	<a href="#">0.36</a>	Model output
Allocation for penalties at max TDP	dB	<a href="#">6.34</a>	Model output Now includes Peye
Allocation for target TP4 eye at max TDP	dB	<a href="#">0</a>	<a href="#">Included in Allocation for penalties at max TDP</a>
Additional insertion loss allowed	dB	0	Model output

Attributes and values in the above table are provided in order to populate example link models and are not presented as specification recommendations. Various model outputs are provided.

# 100G SR4 with KR4 FEC: Example Link Model Jitter Attributes (each lane)

Parameter	Unit	100G SR4	
Signal rate	GBd	25.78125	
Q (BER)		3.8905 (5.00E-5)	FEC corrects BER to < 1.0E-12
TP1 RJrms tolerance, min	UI	0.0079	
TP1 DJ tolerance, min	UI	0.11	
TP3 DCD tolerance, min	UI	0.05	
TP3 DJ tolerance, min	UI	0.243	
TP4 J2, max	UI	0.592	Model output
TP4 TJ at BER, max	UI	0.780	Model output

Attributes and values in the above table are provided in order to populate example link models and are not presented as specification recommendations. Various model outputs are provided.

Nomenclature: Terms TP1, TP2, TP3 and TP4 are used as defined in 802.3 clause 86 and shown in above Figure 1. Note that TP1 is downstream of the input CDR and equalizer for an optical transmitter.

# 100G SR4: Developing TDP Requirements 1

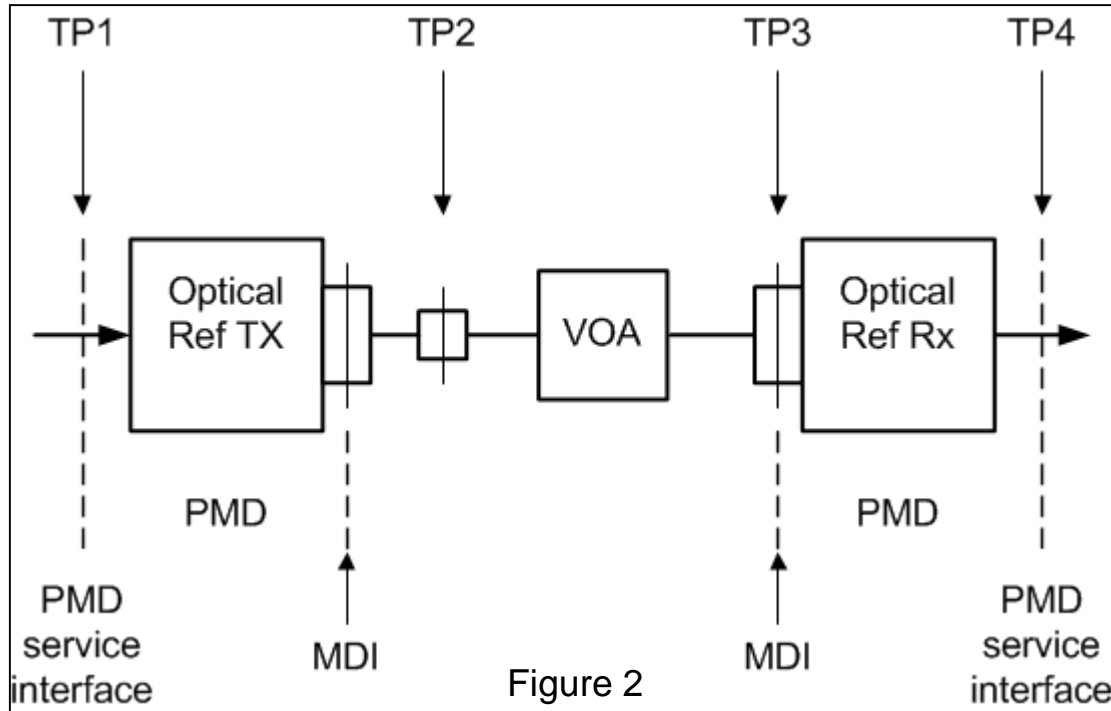

- 1) In setup of Figure 2, adjust VOA to yield TP4 TJ requirement.
- 2) Measure OMA at TP3.
- 3) Determine residual link penalty if any.
- 4) Record OMA + residual link penalty as Test Reference Sensitivity,  $S$ .

- The above figure shows a starting point for development of TDP requirements for a MMF link.
- This is entirely a link model exercise based on idealized reference devices and the defined worst case Tx operating at defined worst case TP1 conditions over the defined worst case optical channel.
- A reference transmitter, Ref Tx, and a reference receiver, Ref Rx, are defined. These are idealized devices and are not expected to be implemented.
- The sensitivity,  $S$ , of the Ref Rx is defined by the signal level at TP3 at the point that the requirements at TP4 are met.
- Link model attributes for Ref Tx and Ref Rx, TP1 and TP3 are provided on following pages.
- In the spread sheet link model cell L7, normally the entry for connector loss, is used to enter the VOA attenuation.



# 100G SR4 with KR4 FEC: Example Ref Tx Attributes

Parameter	Unit	100G SR4	
Signal rate	GBd	25.78125	
Q (BER)		3.8905 (5.0E-5)	FEC corrects BER to < 1.0E-12
Center Wavelength	nm	860	
Spectral Width	nm	0.05	
OMA at max TDP	dBm	-3.0	
Extinction ratio	dB	3.0	
Tx output transition times, 20% -80%	ps	1.0	
RIN <sub>12</sub> OMA	dB/Hz	-128	
RIN coefficient		0	
MPN coefficient		0	
Modal Noise Penalty	dB	0	
Tx reflectance, max	dB	-12	
Tx optical return loss tolerance, max	dB	12	

- Attributes and values in the above table represent an ideal device to use as a reference case. There's no expectation that such a transmitter can be implemented.
- Note that all noise sources are disabled.

# 100G SR4 with KR4 FEC: Example Ref Rx Attributes

Parameter	Unit	100G SR4	
Signal rate	GBd	25.78125	
Q (BER)		3.8905 (5.0E-5)	FEC corrects BER to < 1.0E-12
Wavelength, min	nm	840	
Ref Rx sensitivity (OMA)	dBm	-14.60	-12.03 dBm at Q = 7.034
Rx Bandwidth	MHz	19,336	
RMS base line wander coefficient		0	
Rx reflectance, max	dB	-12	

•Attributes and values in the above table represent an ideal device to use as a reference case.

# 100G SR4 with KR4 FEC: Example Ref Ch Attributes (each lane)

Parameter	Unit	100G SR4	
Signal rate	GBd	25.78125	
Q (BER)		3.8905 (5.0E-5)	FEC corrects BER to < 1.0E-12
Reach	m	2	
Fiber Attenuation	dB/km	0	For 850 nm center wavelength
Dispersion min Uo	nm	1316	
Dispersion So	ps/nm <sup>2</sup> km	0.10275	
Fiber modal bandwidth	MHz·km	2000	
Reflection Noise Factor		0	
Signal power budget at max TDP	dB	11.60	Model output
Fiber Insertion loss	dB	0.00	Model output

Attributes and values in the above table are provided in order to populate a link model representing the test setup for the TDP reference case.

# 100G SR4 with KR4 FEC: Example Ref Tx Ref Rx Link & Jitter Attributes

Parameter	Unit	100G SR4	
Signal rate	GBd	25.78125	
Q (BER)		3.8905 (5.0E-5)	FEC corrects BER to < 1.0E-12
TP1 RJrms	UI	0	
TP1 DJ	UI	0	
TP3 DCD	UI	0	
TP3 DJ	UI	0	
Attenuation (aka Connector loss)	dB	11.50	Adjusted to yield zero margin
TP4 TJ at BER, max	UI	0.780	Model output
<b>Residual Link Power Penalty</b>	<b>dB</b>	<b>0.10</b>	<b>ISI penalty for TP4 TJ = 0.78 UI</b>

- Attributes and values in the above table represent an ideal input at TP1 to use as a reference case. There's no expectation that such an input can be realized.
- Note that the only noise in the link is the noise that determines the sensitivity of the Ref Rx
- Nomenclature: Terms TP1, TP2, TP3 and TP4 are used as defined in 802.3 clause 86 and shown in above Figure 1 and Figure 2.
- For the Ref Tx, Ref Rx, reference channel and TP1 conditions defined above, a VOA attenuation entry of 11.50 dB should yield a TP4 TJ (BER =  $5 \times 10^{-5}$ ) of 0.78 UI consistent with the TP4 requirement in the example link model for an S = -14.6 dBm.

## 100G SR4: Developing TDP Requirements 2

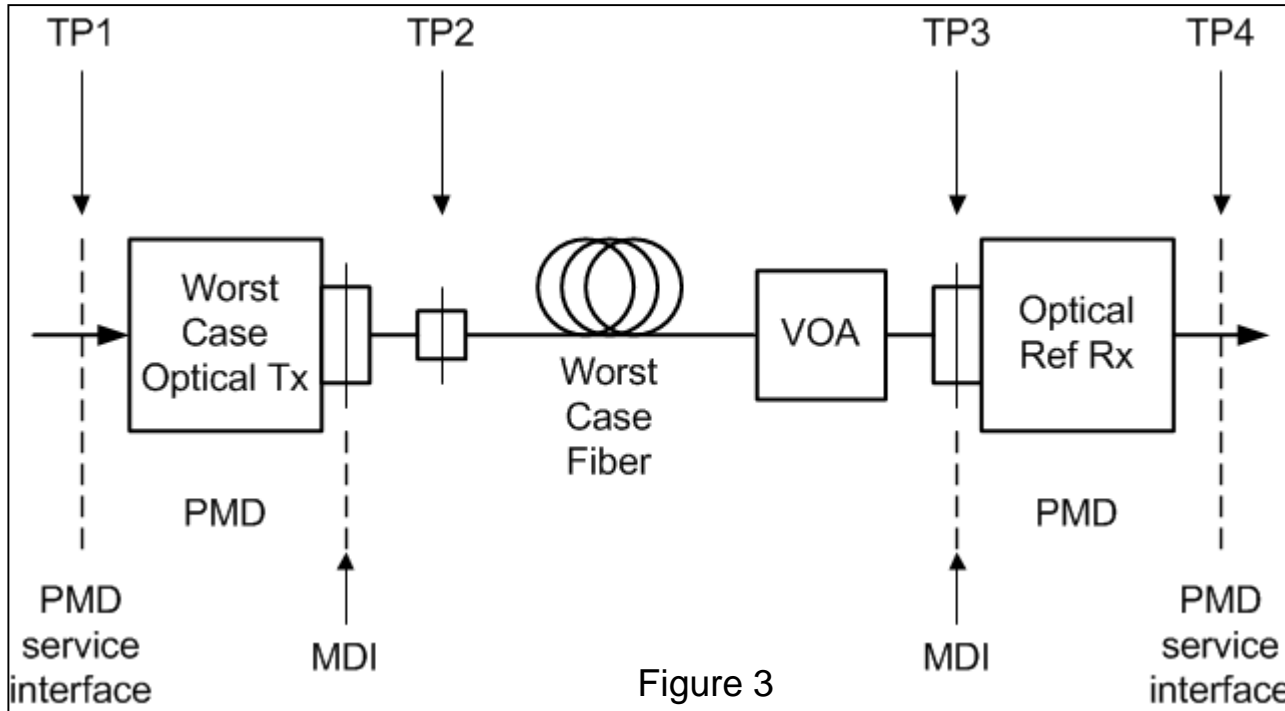

- 1) Replace Ref Tx in Figure 2 with Worst Case Tx, worst case TP1 conditions and Worst Case Fiber as shown in Figure 3.
- 2) Adjust VOA to yield TP4 TJ requirement.
- 3) Record OMA at TP3
- 4)  $\text{Max TDP} = \text{OMA} - \text{Ref Rx } S$ .

- Now that the sensitivity,  $S$ , of the Ref Rx has been established, the Ref Tx and reference channel is replaced by the worst case Tx operating with the worst case TP1 conditions and the worst case optical channel. This channel includes a VOA that is adjusted such that the requirements at TP4 are met.
- The difference between the signal level at TP3 for this case and  $S$  yields the **max limit for TDP, here 5.10 dB**.

# 100G SR4: Developing TDP Requirements 3

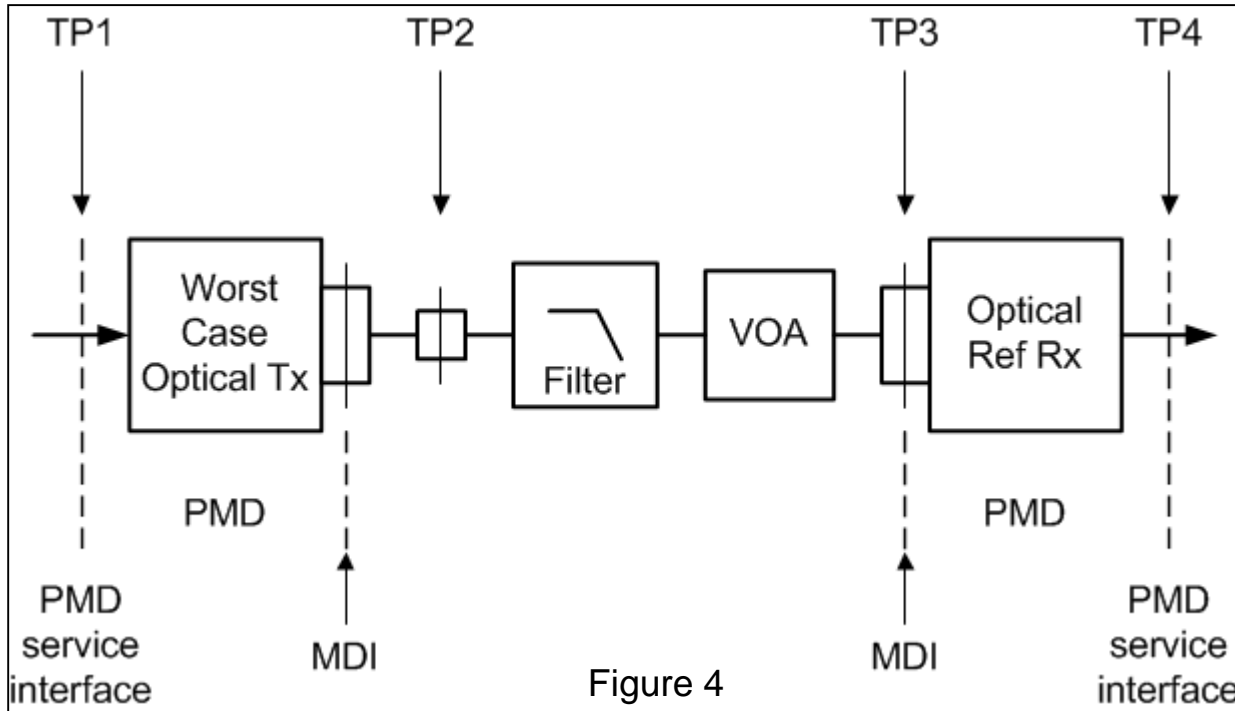

- 1) Replace Worst Case Fiber in Figure 3 with filter.
- 2) Adjust the VOA and Filter bandwidth to yield the same OMA at TP3, the same TP4 TJ and same total link penalties as seen in the setup of Figure 3.
- 3) Combine the bandwidth of the filter and Ref Rx and record as the Rx BW for the TDP measurement.

- Finally, the worst case channel is replaced by the reference channel and a filter is added to the Ref Rx input with a bandwidth that yields the same  $P_{total}$  central (link model cell T28) as did the worst case channel.
- For the example link model, **this filter in combination with the Ref Rx yields a BW of 12.180 GHz.**

# 100G SR4: Developing TDP Requirements 4

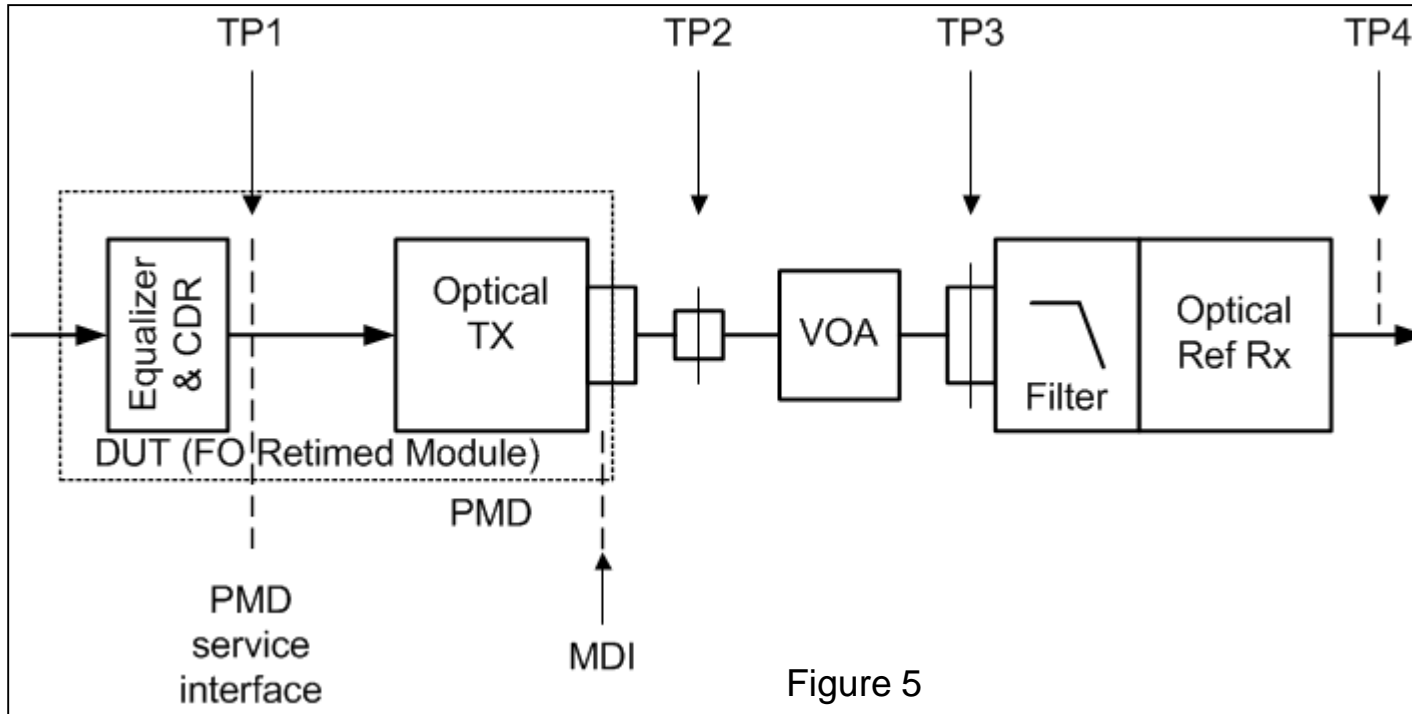

Testing a transceiver module for TDP:

- 1) Replace Worst Case Tx in Figure 4 with Tx DUT as shown in Figure 5.
- 2) Adjust the VOA to yield the same OMA at TP3, the same TP4 TJ and same total link penalties as seen in the setup of Figure 3.
- 3) Note the filter has been combined with the Ref Rx.

# 100G SR4 with KR4 FEC: Example TDP Test Channel (each lane)

Parameter	Unit	100G SR4	
Signal rate	GBd	25.78125	
Q (BER)		3.8905 (5.0E-5)	FEC corrects BER to < 1.0E-12
Reach	m	2	
Fiber Attenuation	dB/km	0.0	For 850 nm center wavelength
Dispersion min Uo	nm	1316	
Dispersion So	ps/nm <sup>2</sup> km	0.10275	
Fiber modal bandwidth	MHz·km	2000	
Reflection Noise Factor		0	
Signal power budget at max TDP	dB	11.60	Model output
Fiber Insertion loss	dB	0.00	Model output
Attenuation (aka Connector loss)	dB	6.50	Adjusted to yield zero margin
Rx Bandwidth for TDP	MHz	12180	Adjusted to match P <sub>tot</sub> of Ref Ch with 100 m of OM4
Max TDP	dB	5.10	

Attributes and values in the above table provide a summary of the test channel using the TDP filter.



# Eye Mask Coordinates Reference/Definition

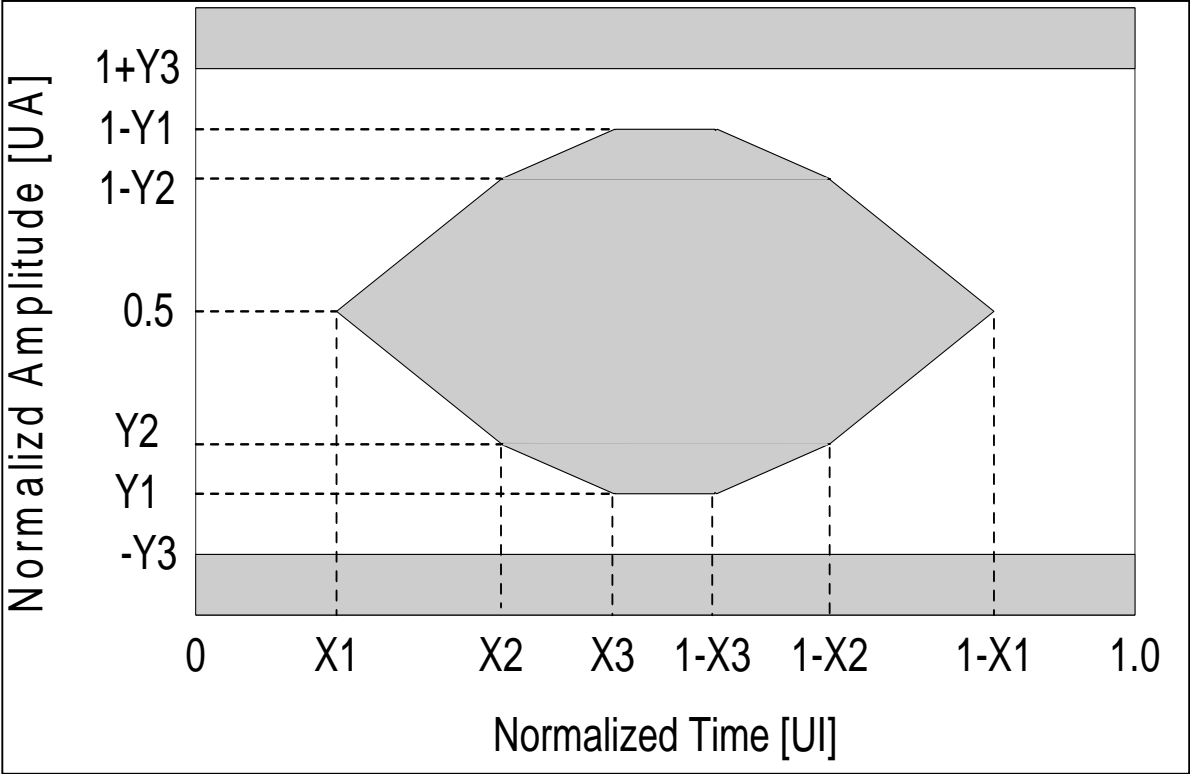

# 100G SR4: Developing Tx Eye Mask Requirements

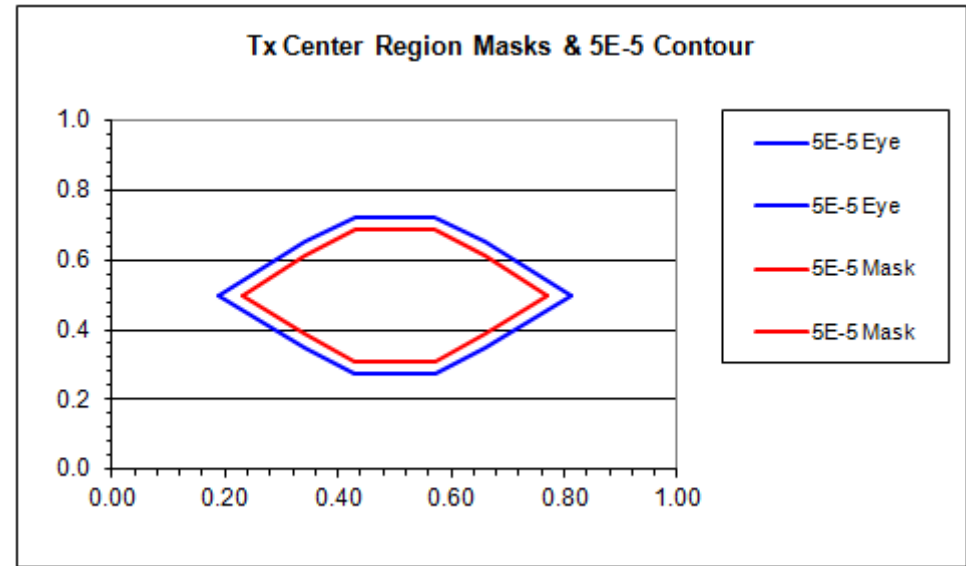
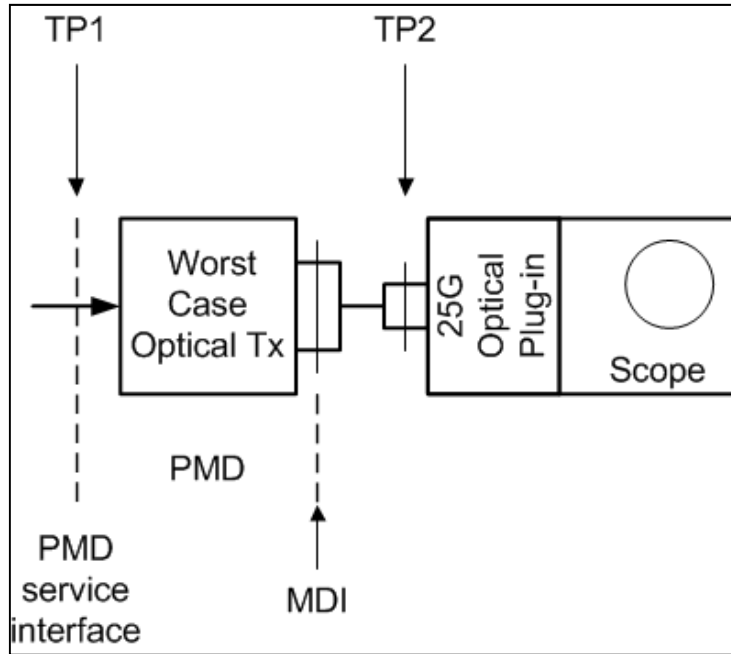

- The Worst Case Tx and worst case TP1 conditions used to determine Max TDP are used to define the coordinates for the Tx Eye mask.
- A link model can be setup to represent an oscilloscope with an optical plugin that matches the sensitivity and bandwidth characteristics of the Ref Rx.
- The 5E-5 jitter contour at TP2 as observed by the Ref Rx can be determined from the link model.
- Since the Tx Eye mask is used to control aberrant waveforms and not jitter mask coordinates are chosen to provide a mask slightly relaxed from the 5E-5 contour.
- Proposed mask coordinates are  $X1 = 0.23$  UI,  $X2 = 0.34$  UI,  $X3 = 0.43$  UI,  $Y1 = 0.31$  UA,  $Y2 = 0.39$  UA ,  $Y3 = 0.40$**

# 100G SR4: Developing SRS Requirements

- To test the optical Rx, the worst case signal expected at TP3 should be reproduced as the Rx input condition.
- This represents the worst case Tx operating with the worst case TP1 conditions over the worst case fiber including the maximum connector loss.
- The amplitude of this stressed signal is determined by the min OMA at max TDP adjusted by the max channel insertion loss and power penalties (yielding SRS OMA) and further reduced by the ISI power penalty associated with the Ref Rx (yielding VECP).
- The example link model includes calculations for SRS OMA (cell X28 for 100 m) and VECP (cell W11).
- Since VECP is defined for the center of the eye, the tab Base(c) provides the appropriate values for **SRS OMA (-5.57 dBm)** and **VECP (3.55 dB)**.
- In the Base(c) tab, the TP4 eye requirement is not included as an element of DJ so that the power penalties are calculated at the center of the eye.
- In addition to vertical stress, jitter is added (J in Clause 52, J2 and J9 in Clause 86) for horizontal stress. A link model can be setup to calculate the expected worst case jitter at TP3. Since this link is operating at a max BER = 5E-5, **J2 (0.41 UI)** and **J4 (0.55 UI)** may be appropriate choices for jitter stress.
- However instead of decomposing eye form by the jitter contour into vertical and horizontal stressors, perhaps an eye mask representing the contour can be used.

# 100G SR4: Developing SRS Requirements

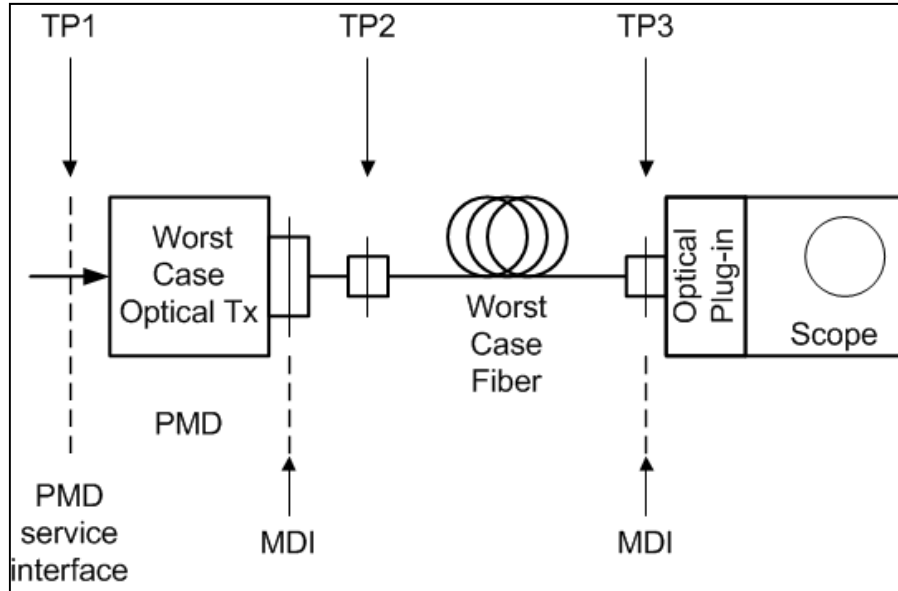

- As with determining the coordinates for the Tx eye mask, a link model can be setup to determine stressed receiver conditions that represent the worst case conditions expected at TP3.
- Here the worst case fiber including maximum connector loss is inserted between the worst case Tx and scope used to observe the jitter contours at TP2.
- On the right, three jitter contours are shown in the upper chart and it can be seen that the contour approaches a diamond shape. In the lower chart, it can be seen that a diamond shaped mask fairly approximates the 5E-5 contour.
- Coordinates for the 5E-5 contour are  $X1 = 0.21 \text{ UI}$ ,  $X2 = 0.5 \text{ UI}$ ,  $X3 = 0.5 \text{ UI}$ ,  $Y1 = 0.28 \text{ UA}$ ,  $Y2 = 0.28 \text{ UA}$ ,  $Y3 = 0.4 \text{ UA}$
- Note  $Y1 = 0.28 \text{ UI}$  aligns with a VECP of 3.57 dB

