

500 m SMF Objective Baseline Proposal

Jon Anderson, Oclaro

John Petrilla, Avago Technologies

Tom Palkert, Luxtera

*IEEE P802.3bm 40 Gb/s & 100 Gb/s Optical Ethernet Task Force
SMF Ad Hoc Conference Call, Feb. 12, 2013*

Supporters

- Chris Bergey, Luxtera
- Brian Welch, Luxtera
- Kiyoo Hiramoto, Oclaro
- David Cunningham, Avago Technologies

Introduction

- This presentation provides a baseline specification proposal for a retimed PMD to address the P802.3bm objective:
Define a 100 Gb/s PHY for operation up to at least 500 m of SMF.
- The baseline proposal is based on “PSM4” technology and optical parameter specifications presented in:
 - [anderson_01_0113_optx](#), [anderson_01a_1112_optx](#)
 - [petrilla_02a_0113_optx](#), [petrilla_03a_optx](#)
 - [palkert_01_1112_optx](#) , [welch_01a_0113_optx](#)
- Baseline Specification Summary:
 - 4 lane parallel, 25.78125 GBd/lane, 1310 nm single mode optical PMD for 100GBASE-nR4;
 - FEC supported retimed interface is utilized to enable a low cost 500 m SMF PMD;
 - 4 optical lanes directly map to 4 electrical lanes, without requiring multiplexing, translation or de-skewing inside the module.
- This baseline specification is proposed by multiple optical module suppliers, demonstrating technical and economic feasibility of the proposed solution.
- This baseline proposal is supported by multiple component suppliers, systems suppliers and data center operators, demonstrating broad market potential of the proposed solution. (To be demonstrated).

Proposed link architecture

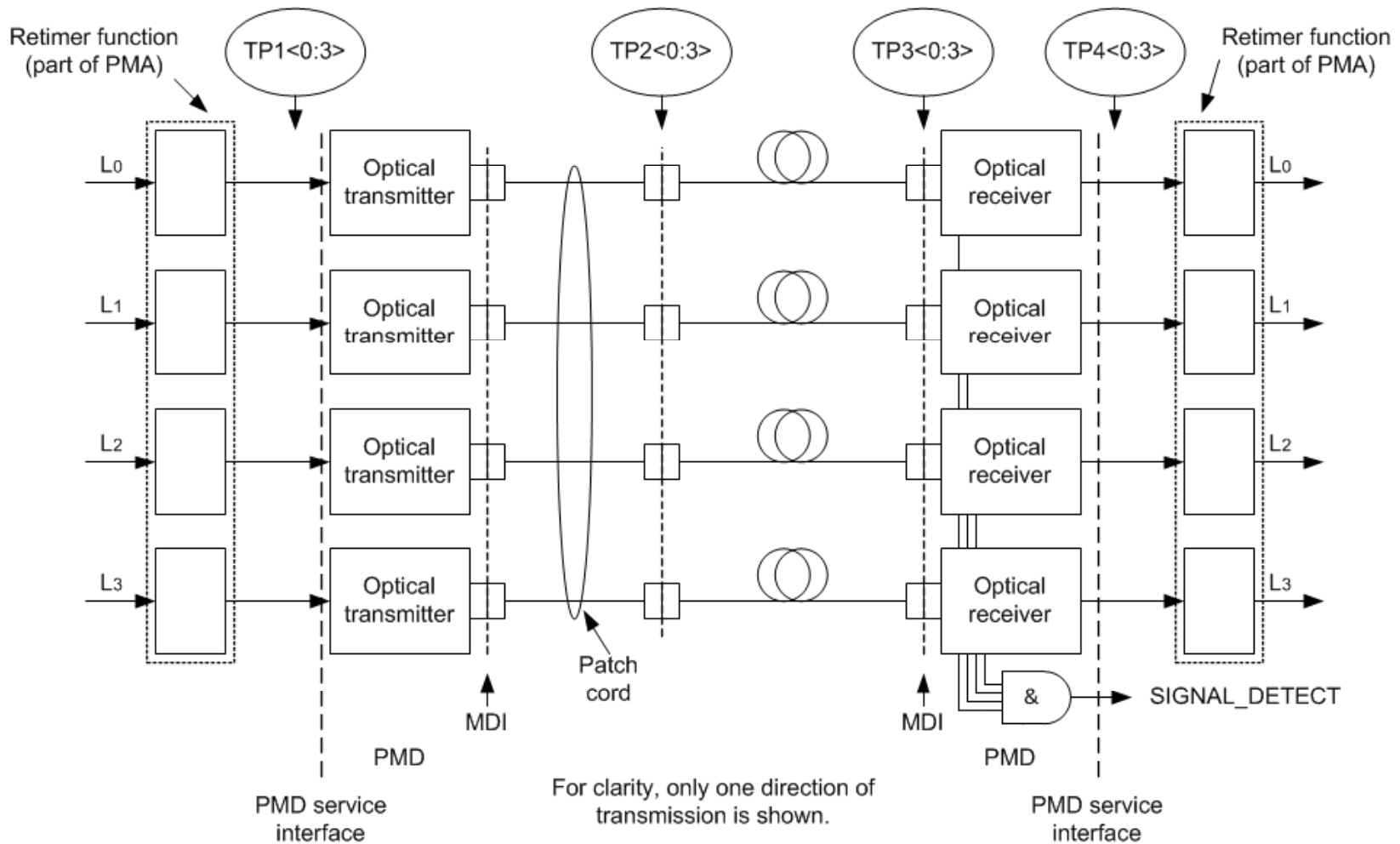

- TP1 and TP4, shown here for illustration only, represent the start and end of link budget calculations. They may not be accessible points for measurements, nor are they intended as reference points for specifications.

Proposed position in 802.3 architecture

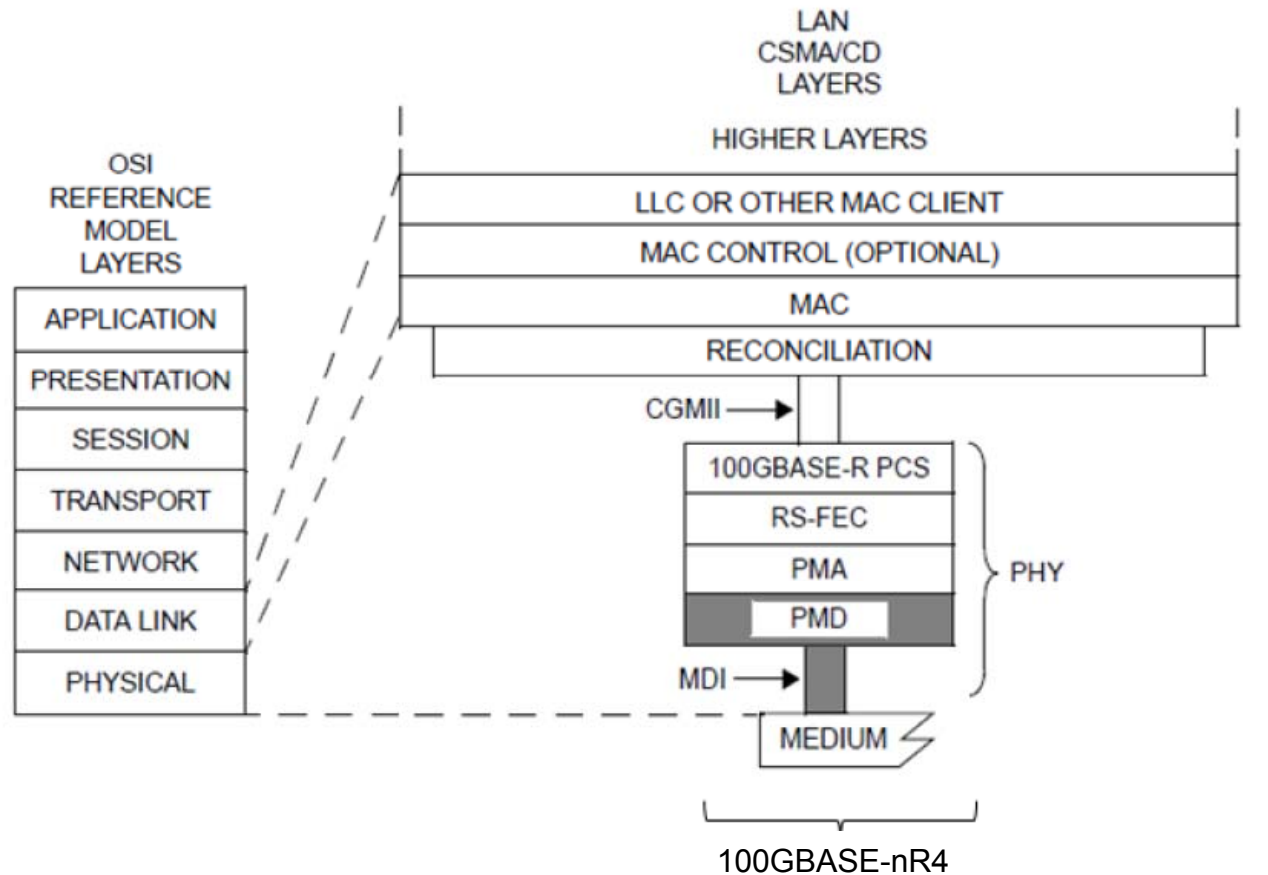

CGMII = 100 Gb/s MEDIA INDEPENDENT INTERFACE
 LLC = LOGICAL LINK CONTROL
 MAC = MEDIA ACCESS CONTROL
 MDI = MEDIUM DEPENDENT INTERFACE

PCS = PHYSICAL CODING SUBLAYER
 PHY = PHYSICAL LAYER DEVICE
 PMA = PHYSICAL MEDIUM ATTACHMENT
 PMD = PHYSICAL MEDIUM DEPENDENT
 RS-FEC = REED-SOLOMON FORWARD ERROR CORRECTION

100GBASE- nR4 Illustrative link power budget

Parameter	Unit	Proposed 100GBASE-nR4 500m	Comment
Power budget (at max TDP)	dB	6.4	
Operating distance	km	0.50	
Maximum fiber loss ^a	dB/km	0.42	
Optical connector loss	dB	3.0	
Channel insertion loss (max)	dB	3.2	
Channel insertion loss (min)	dB	0	
Maximum discrete reflectance	dB	-12	Transmitter and Receiver module connectors are at -12dB. In-line connectors are at -55dB.
Allocation for penalties (at max TDP) ^b	dB	2.8	
Allocation for TP4 eye opening (at max TDP) ^b	dB	0.4	
Additional insertion loss allowed	dB	0	

Note a: The channel insertion loss is calculated using the specified operating distance and maximum optical fiber attenuation loss of 0.42 dB/km at 1310 nm plus allocation for connection and splice loss as specified.

Note b: Link penalties are used for link budget calculations. They are not requirements and are not meant to be tested.

100GBASE- nR4 Transmit Characteristics

Parameter	Unit	Proposed 100GBASE-nR4 500m	Comment
Signaling rate, each lane (range)	GBd	25.78125 +/- 100 ppm	
Lane wavelengths (range)	nm	1295 to 1325	
Side-mode suppression ratio (SMSR)(min)	dB	30	
Total average launch power (max)	dBm	8.0	
Average launch power, each lane (max)	dBm	2.0	
Average launch power, each lane (min) ^a	dBm	-9.0	
Optical Modulation Amplitude (OMA) (max)	dBm	2.2	
Transmitter and dispersion penalty (TDP), each lane (max)	dB	2.8	
Min OMA at max TDP, each lane	dBm	See Note b	

Note a: Average launch power, each lane (min) is informative and not the principal indicator of signal strength. A transmitter with launch power below this value cannot be compliant; however, a value above this value does not ensure compliance.

Note b: Trade-offs are available between minimum transmit OMA, center wavelength offset and TDP. See Table 1 and Figure 1.

100GBASE- nR4 Transmit Characteristics Cont.

Parameter	Unit	Proposed 100GBASE-nR4 500m	Comment
Average launch power of OFF transmitter, each lane (max)	dBm	-30	
Extinction ratio (min)	dB	3.5	
Optical return loss tolerance (max)	dB	12	
Transmitter reflectance (max) ^c	dB	-12	
Transmitter eye mask definition {X1, X2, X3, Y1, Y2, Y3}		FFS (For Further Study)	

Note c: Transmitter reflectance is defined looking into the transmitter.

Table 1: 100GBASE-nR4 minimum transmit OMA as a function of center wavelength offset and TDP

Wavelength, nm		Transmitter and Dispersion Penalty, dB																
Min	Max	2.6	2.5	2.4	2.3	2.2	2.1	2	1.9	1.8	1.7	1.6	1.5	1.4	1.3	1.2	1.1	1
1324	1325	-3.10	-3.14	-3.19	-3.23	-3.28	-3.32	-3.36	-3.41	-3.45	-3.49	-3.54	-3.58	-3.63	-3.67	-3.71	-3.76	-3.80
1323	1324	-3.58	-3.63	-3.67	-3.71	-3.76	-3.80	-3.85	-3.89	-3.93	-3.98	-4.02	-4.06	-4.11	-4.15	-4.20	-4.24	-4.28
1322	1323	-4.03	-4.08	-4.12	-4.16	-4.21	-4.25	-4.30	-4.34	-4.38	-4.43	-4.47	-4.51	-4.56	-4.60	-4.65	-4.69	-4.73
1321	1322	-4.45	-4.49	-4.54	-4.58	-4.63	-4.67	-4.71	-4.76	-4.80	-4.84	-4.89	-4.93	-4.98	-5.02	-5.06	-5.11	-5.15
1320	1321	-4.83	-4.88	-4.92	-4.96	-5.01	-5.05	-5.10	-5.14	-5.18	-5.23	-5.27	-5.31	-5.36	-5.40	-5.45	-5.49	-5.53
1319	1320	-5.18	-5.23	-5.27	-5.31	-5.36	-5.40	-5.45	-5.49	-5.53	-5.58	-5.62	-5.66	-5.71	-5.75	-5.80	-5.84	-5.88
1318	1319	-5.50	-5.54	-5.59	-5.63	-5.68	-5.72	-5.76	-5.81	-5.85	-5.89	-5.94	-5.98	-6.00	-6.00	-6.00	-6.00	-6.00
1317	1318	-5.78	-5.83	-5.87	-5.91	-5.96	-6.00	-6.00	-6.00	-6.00	-6.00	-6.00	-6.00	-6.00	-6.00	-6.00	-6.00	-6.00
1303	1317	-6.00	-6.00	-6.00	-6.00	-6.00	-6.00	-6.00	-6.00	-6.00	-6.00	-6.00	-6.00	-6.00	-6.00	-6.00	-6.00	-6.00
1302	1303	-5.78	-5.83	-5.87	-5.91	-5.96	-6.00	-6.00	-6.00	-6.00	-6.00	-6.00	-6.00	-6.00	-6.00	-6.00	-6.00	-6.00
1301	1302	-5.50	-5.54	-5.59	-5.63	-5.68	-5.72	-5.76	-5.81	-5.85	-5.89	-5.94	-5.98	-6.00	-6.00	-6.00	-6.00	-6.00
1300	1301	-5.18	-5.23	-5.27	-5.31	-5.36	-5.40	-5.45	-5.49	-5.53	-5.58	-5.62	-5.66	-5.71	-5.75	-5.80	-5.84	-5.88
1299	1300	-4.83	-4.88	-4.92	-4.96	-5.01	-5.05	-5.10	-5.14	-5.18	-5.23	-5.27	-5.31	-5.36	-5.40	-5.45	-5.49	-5.53
1298	1299	-4.45	-4.49	-4.54	-4.58	-4.63	-4.67	-4.71	-4.76	-4.80	-4.84	-4.89	-4.93	-4.98	-5.02	-5.06	-5.11	-5.15
1297	1298	-4.03	-4.08	-4.12	-4.16	-4.21	-4.25	-4.30	-4.34	-4.38	-4.43	-4.47	-4.51	-4.56	-4.60	-4.65	-4.69	-4.73
1296	1297	-3.58	-3.63	-3.67	-3.71	-3.76	-3.80	-3.85	-3.89	-3.93	-3.98	-4.02	-4.06	-4.11	-4.15	-4.20	-4.24	-4.28
1295	1296	-3.10	-3.14	-3.19	-3.23	-3.28	-3.32	-3.36	-3.41	-3.45	-3.49	-3.54	-3.58	-3.63	-3.67	-3.71	-3.76	-3.80

Figure 1: 100GBASE-nR4 minimum transmit OMA as a function of 1310nm center wavelength offset and TDP

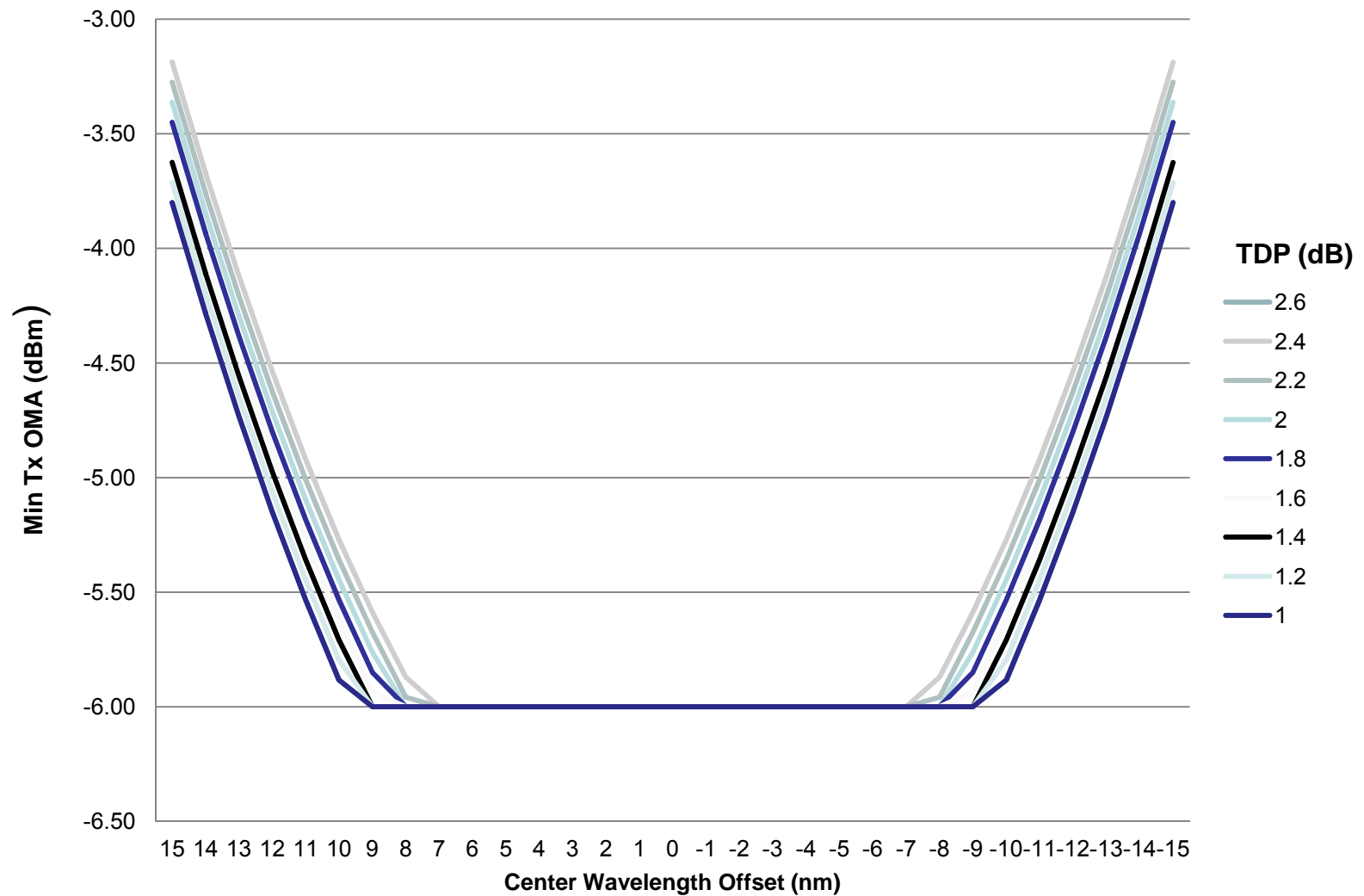

100GBASE- nR4 Receive Characteristics

Parameter	Unit	Proposed 100GBASE-nR4 500m	Comment
Signaling rate, each lane (range)	GBd	25.78125 +/- 100 ppm	
Lane wavelengths (range)	nm	1295 to 1325	
Damage threshold ^a	dBm	3.0	
Average receive power, each lane (max)	dBm	2.0	
Average receive power, each lane (min) ^b	dBm	-12.2	
Receive power, each lane (OMA) (max)	dBm	2.2	
Receiver reflectance (max)	dB	-12	
Receiver sensitivity at target BER (OMA), each lane (max) ^c	dBm	-9.46 at Q=3.8905 (5E-5) (-6.89 at Q=7.034,1E-12)	KR4 FEC corrects 100GBASE-nR4 BER to $\leq 1E-12$

Note a: The receiver shall be able to tolerate, without damage, continuous exposure to an optical input signal having this average power level.

Note b: Average receive power, each lane (min) is informative and not the principal indicator of signal strength. A received power below this value cannot be compliant; however, a value above this does not ensure compliance.

Note c: Receiver sensitivity (OMA), each lane (max) is informative.

100GBASE- nR4 Receive Characteristics Cont.

Parameter	Unit	Proposed 100GBASE-nR4 500m	Comment
Stressed receiver sensitivity (OMA), each lane (max) ^d	(dBm)	FFS	
Conditions of stressed receiver sensitivity test:			
Vertical eye closure penalty, each lane ^e	(dB)	1.8	
Stressed eye J2 Jitter, each lane ^e	(UI)	FFS	
Stressed eye J9 Jitter, each lane ^e	(UI)	FFS	

Note d: Measured with conformance test signal at TP3 (see 87.8.11) for BER = 5E-5.

Note e: Vertical eye closure penalty, stressed eye J2 Jitter and stressed eye J9 Jitter are test conditions for measuring stressed receiver sensitivity. They are not characteristics of the receiver.

Summary & Next Steps

- A baseline specification proposal for the 500 m SMF objective 100GBASE-nR4 has been presented.
- Use of KR4 FEC (defined in draft CI 91) is employed for relaxing Tx and Rx specifications for a 500 m SMF link.
- Transmitter OMA is specified as tradeoff relationship of OMA min versus center wavelength offset versus TDP max for enabling multi-supplier (technology) interoperable link solution.
- Complete FFS parameters and fine tune specifications.

Relevant 802.3bm Objective & Criteria

From 802.3bm Objectives:

“Define a 100 Gb/s PHY for operation up to at least 500 m of SMF”

From 802.3bm Distinct Identity:

“The amendment will enable new PHY types over SMF which consist of the existing 100GBASE-LR4 and 100GBASE-ER4 optical PMDs with four electrical interconnect lanes in each direction.

The amendment will define a new 100 Gb/s SMF PMD in addition to these if it can be shown that a SMF PMD with a shorter reach than 100GBASE-LR4 has sufficient cost, density, or power difference to justify an additional SMF PMD type.”

Key Tx Attributes (each lane): 10G LR, 100G LR4 & 100G PSM4

Parameter	Unit	10G LR	100G LR4	100G PSM4	Comment
Signal rate	GBd	10.3125	25.78125		
Q (BER)		7.034 (10^{-12})		3.89 (5×10^{-5})	KR4 FEC corrects PSM4 BER to $\leq 10^{-12}$
Center Wavelength, min	nm	1260	1294.53	1295	32GFC has a 1295 to 1325 nm range
Center Wavelength Range, max	nm	95	2.1	30	Laser cooling required for LR4 range
OMA at max TDP & wavelength offset, min	dBm	-3.0	-0.1	-3.1	
Extinction ratio, min	dB	3.5	4.0	3.5	
Tx output transition times, 20% -80%, max	ps	47	12	18	
RINcOMA, max	dB/Hz	-128	-130	-128	For 10G LR & 100G PSM4, $c = 12$, for 100G LR4, $c = 20$.
Tx reflectance, max	dB	-12			
Tx optical return loss tolerance, max	dB	12	20	12	

- The higher min OMA at max TDP for LR4 combined with the MUX insertion loss results in a higher min output requirement from the DFB laser leading to higher bias/modulation currents and power consumption. These higher DFB currents are reduced as a consequence of lower DFB operating temperatures provided by the TEC. For equivalent DFBs, where optical power limited, a multiple $\sim 1.8x$ may be seen. However, using TEC can result in significant power consumption. For $\sim 30C$ cooling TEC power consumption of ~ 0.25 W/lane is expected.

- For LR4, the faster transition time requirement combined with the high drive currents may force use of SiGe laser drivers for some time.

- 100G PSM4 is defined to have a cost/performance structure more like 10G LR than 100G LR4.

Key Rx Attributes (each lane): 10G LR, 100G LR4 & 100G PSM4

Parameter	Unit	10G LR	100G LR4	100G PSM4	Comment
Signal rate	GBd	10.3125	25.78125		
Q (BER)		7.034 (10^{-12})		3.89 (5×10^{-5})	KR4 FEC corrects PSM4 BER to $\leq 10^{-12}$
Center Wavelength, min	nm	1260	1294.53	1295	
Center Wavelength Range, max	nm	95	2.1	30	
Rx Sensitivity (OMA), max	dBm	-12.6	-8.6	-9.46 (-6.89 at Q = 7.034)	
Rx reflectance, max	dB	-12	-26	-12	

For PSM4 relative to LR4 (due to shorter reach, absence of DMUX and FEC)

- Relaxed max Rx reflection permits lower cost optics
- Relaxed max Rx sensitivity permits lower cost optical assembly & alignment
- Relaxed max BER permits faster and lower cost sensitivity tests

Size, Power & Cost Estimates: 100G SR10, SR4, LR4 & PSM4

	100G SR10	100G SR4	100G LR4	100G PSM4	Comments
Lane Count	10	4	4	4	
Signal Rate/Lane	10.31 GBd	25.78 GBd	25.78 GBd	25.78 GBd	
<u>XCVR Power Consumption</u>					
XCVR Total	3000 mW	2640 mW	7000 mW	3760 mW	petrilla_03a_0113_optx.pdf
<u>Density</u>					
Form Factor	CXP	QSFP28		QSFP28	QSFP28 if power consumption < 3.5 W CFP4 if power consumption < 6.0 W petrilla_03a_0113_optx.pdf
		CFP4	CFP2	CFP4	
<u>Relative XCVR Cost</u>	1x	1.1x	12x	4x	petrilla_03a_0113_optx.pdf
		< 0.43x	1x	0.43x	anderson_01_0113_optx.pdf
	1.42x		4.93x	1.17x	welch_01a_0113_optx.pdf

Prior analyses indicate that a 100G PSM4 based implementation in a CFP4 form factor supporting the 500 m SMF objective, can have 0.54x the power, 0.5x the size (2x density), for 0.43x to 0.24x the cost of an 100G LR4.

With modest reduction of power consumption, the 100G PSM4 may be implemented in a QSFP28 form factor yielding additional density benefit.

Size, Power & Cost Estimate Comparison Conclusion

- The proposed 100G PSM4 transceivers offer sufficiently significant cost, density and power advantages relative to expected 100G LR4 implementations to justify a new PMD.

Broad Market Acceptance of parallel SMF in data centers

Parallel fiber use is not new in the data center. Ethernet adopted MMF objectives for 802.3ba in July 2007 for 40GBASE-SR4 and 100GBASE-SR10 that depend on parallel fiber.

InfiniBand used 4-lane channels (4x) and 12-lane channels (12x) implementations beginning circa 2000 at 2.5G then 5.0G and 10G rates and expects to continue at 14G and 25G

Concerns associated with bending ribbon cables were resolved with the introduction of circular cross section assemblies.

...

Survey of four top-ranked internet datacenter operators provided the following feedback .

- a. 3 out of 4 agreed with the PSM4 proposal and would purchase the products when available. The one not in favor of the proposal would use PSM4 to replace SR4 if cost parity was reached.
- b. Two of the surveyed companies would like to see the SMF PSM4 concept used today to aggregate four 10GE transceivers into one module and/or as an alternative implementation of 40 GE followed by the 4x25G optics in 2014 – 2015.

petrilla_01a_0312_NG100GOPTX.pdf

anderson_01_0213_smf

End of Presentation

Thanks!