

802.3bn Link Ad Hoc

Meeting Notes & Baseline

Agenda, Notes – 2/7/13

- Conference Call at 9am-10am
- IEEE Patent Policy Reviewed
- Attendance Taken – See slide
- Duane & Ed's slides on configuration options

Agenda, Notes – 1/31/13

- Conference Call at 9am-10am
- IEEE Patent Policy Reviewed
- Attendance Taken – See slide
- Link Capacity - Duane

Agenda, Notes – 1/23/13

- 8am Meeting at Interim
- IEEE Patent Policy Reviewed at main meeting
- Link Presentation – Avi, Broadcom
- Attendance taken at Interim
- Reviewed Straw polls and reworded to motions
- Passed 3 motions (3-5)

Agenda, Notes – 1/17/13

- Conference Call at 9am-10am
- IEEE Patent Policy Reviewed
- Link Presentation – Avi, Broadcom
- Attendance Taken – See slide
- Straw Polls #2 & #3 taken

Agenda, Notes – 1/10/13

- Conference Call at 9am-10am
- IEEE Patent Policy Reviewed
- Attendance Taken – See slide
- Continued discussion on Link Transport
 - Discussion on the number of PHY link channels needed in the downstream.
 - Started discussion on PHY link for the upstream

Agenda, Notes – 12/20/12

- Conference Call at 9am-10am
- IEEE Patent Policy Reviewed
- Attendance Taken – See slide
- Continued discussion on Link Transport
 - Discussion on the number of PHY link channels needed in the downstream.
 - Started discussion on PHY link for the upstream

Agenda, Notes – 12/13/12

- Conference Call at 9am-10am
- IEEE Patent Policy Reviewed
- Attendance Taken – See slide
- Continued discussion on Link Transport
 - Continued calculation of the required data rate
 - Updated the parameters/status indicator slides
 - Draft for straw poll #2 selecting the fixed modulation order for the PHY Link Channel.

Agenda, Notes – 12/6/12

- Conference Call at 9am-10am
- IEEE Patent Policy Reviewed
- Attendance Taken – See slide
- Continued discussion on Link Transport
 - Continued calculation of the required data rate
 - Updated the parameters/status indicator slides
 - Draft for straw poll #2 selecting the fixed modulation order for the PHY Link Channel.

Agenda, Notes – 11/29/12

- Conference Call at 9am-10am
- IEEE Patent Policy Reviewed
- Attendance Taken – See slide
- Continued discussion on Link Transport
 - Drawing/Table for general downstream transport definition
 - Started a budget slide for start up time
 - Continued calculation of the required data rate

Agenda, Notes – 11/20/12

- Conference Call at 5pm-6pm
- IEEE Patent Policy Reviewed
- Attendance Taken – See slide
- Continued discussion on Link Transport
 - Drawing for general downstream transport
 - Start calculation of the required data rate

Agenda, Notes – 11/14/12

- IEEE Patent Policy Reviewed at main meeting
- No attendance – Taken at main meeting
- Qualcomm presentation on link transport in main meeting (attached)
- Broadcom presentation on link transport in main meeting (attached)
- Continued discussion on Link Transport
- Complete Straw Poll Passed

Agenda, Notes – 11/8/12

- IEEE Patent Policy Reviewed – Agreed and no known patents
- Attendance Taken – See Attendance slide
- Feedback on Victor's Wireless Presentation
- Continued discussion on Link Transport
 - Ability to handle ingress noise
 - Options for placement based on a frequency grid
- Fixed half of a straw poll (only the yes votes)

PATENTS

Instructions for the WG Chair

The IEEE-SA strongly recommends that at each WG meeting the chair or a designee:

- Show slides #1 through #4 of this presentation
- Advise the WG attendees that:
 - The IEEE's patent policy is described in Clause 6 of the *IEEE-SA Standards Board Bylaws*;
 - Early identification of patent claims which may be essential for the use of standards under development is strongly encouraged;
 - There may be Essential Patent Claims of which the IEEE is not aware. Additionally, neither the IEEE, the WG, nor the WG chair can ensure the accuracy or completeness of any assurance or whether any such assurance is, in fact, of a Patent Claim that is essential for the use of the standard under development.
- Instruct the WG Secretary to record in the minutes of the relevant WG meeting:
 - That the foregoing information was provided and that slides 1 through 4 (and this slide 0, if applicable) were shown;
 - That the chair or designee provided an opportunity for participants to identify patent claim(s)/patent application claim(s) and/or the holder of patent claim(s)/patent application claim(s) of which the participant is personally aware and that may be essential for the use of that standard
 - Any responses that were given, specifically the patent claim(s)/patent application claim(s) and/or the holder of the patent claim(s)/patent application claim(s) that were identified (if any) and by whom.
- The WG Chair shall ensure that a request is made to any identified holders of potential essential patent claim(s) to complete and submit a Letter of Assurance.
- It is recommended that the WG chair review the guidance in *IEEE-SA Standards Board Operations Manual 6.3.5* and in FAQs 12 and 12a on inclusion of potential Essential Patent Claims by incorporation or by reference.

Note: WG includes Working Groups, Task Groups, and other standards-developing committees with a PAR approved by the IEEE-SA Standards Board.

(Optional to be shown)

25 March 2008 (updated January 2012)



Participants, Patents, and Duty to Inform

All participants in this meeting have certain obligations under the IEEE-SA Patent Policy.

- Participants [Note: Quoted text excerpted from IEEE-SA Standards Board Bylaws subclause 6.2]:
 - “Shall inform the IEEE (or cause the IEEE to be informed)” of the identity of each “holder of any potential Essential Patent Claims of which they are personally aware” if the claims are owned or controlled by the participant or the entity the participant is from, employed by, or otherwise represents
 - “Personal awareness” means that the participant “is personally aware that the holder may have a potential Essential Patent Claim,” even if the participant is not personally aware of the specific patents or patent claims
 - “Should inform the IEEE (or cause the IEEE to be informed)” of the identity of “any other holders of such potential Essential Patent Claims” (that is, third parties that are not affiliated with the participant, with the participant’s employer, or with anyone else that the participant is from or otherwise represents)
- The above does not apply if the patent claim is already the subject of an Accepted Letter of Assurance that applies to the proposed standard(s) under consideration by this group
- Early identification of holders of potential Essential Patent Claims is strongly encouraged
- No duty to perform a patent search

Patent Related Links

All participants should be familiar with their obligations under the IEEE-SA Policies & Procedures for standards development.

Patent Policy is stated in these sources:

IEEE-SA Standards Boards Bylaws

<http://standards.ieee.org/develop/policies/bylaws/sect6-7.html#6>

IEEE-SA Standards Board Operations Manual

<http://standards.ieee.org/develop/policies/opman/sect6.html#6.3>

Material about the patent policy is available at

<http://standards.ieee.org/about/sasb/patcom/materials.html>

If you have questions, contact the IEEE-SA Standards Board Patent Committee Administrator at patcom@ieee.org or visit <http://standards.ieee.org/about/sasb/patcom/index.html>

This slide set is available at
<https://development.standards.ieee.org/myproject/Public/mytools/mob/slideset.ppt>

Call for Potentially Essential Patents

- If anyone in this meeting is personally aware of the holder of any patent claims that are potentially essential to implementation of the proposed standard(s) under consideration by this group and that are not already the subject of an Accepted Letter of Assurance:
 - Either speak up now or
 - Provide the chair of this group with the identity of the holder(s) of any and all such claims as soon as possible or
 - Cause an LOA to be submitted

Other Guidelines for IEEE WG Meetings

- **All IEEE-SA standards meetings shall be conducted in compliance with all applicable laws, including antitrust and competition laws.**
 - **Don't discuss the interpretation, validity, or essentiality of patents/patent claims.**
 - **Don't discuss specific license rates, terms, or conditions.**
 - Relative costs, including licensing costs of essential patent claims, of different technical approaches may be discussed in standards development meetings.
 - Technical considerations remain primary focus
 - **Don't discuss or engage in the fixing of product prices, allocation of customers, or division of sales markets.**
 - **Don't discuss the status or substance of ongoing or threatened litigation.**
 - **Don't be silent if inappropriate topics are discussed ... do formally object.**

See *IEEE-SA Standards Board Operations Manual*, clause 5.3.10 and "Promoting Competition and Innovation: What You Need to Know about the IEEE Standards Association's Antitrust and Competition Policy" for more details.

ATTENDEES

Attendance – 2/7/13 Conf Call

- **Ed Boyd, Broadcom**
- **Bill Keasler, Ikanos**
- **Mark Laubach, Broadcom**
- **Raanan Ivry, Widepass**
- **Duane Remein, Huawei**
- **Avi Kliger, Broadcom**
- **Steve Shellhammer, Qualcomm**
- **Marek Hajduczenia, ZTE**
- **Christian Pietsch, Qualcomm**
- **Juan Montojo, Qualcomm**
- **Bill Powell, Alcatel**

Attendance – 1/31/13 Conf Call

- **Ed Boyd, Broadcom**
- **Bill Keasler, Ikanos**
- **Mark Laubach, Broadcom**
- **Raanan Ivry, Widepass**
- **Duane Remein, Huawei**
- **Avi Kliger, Broadcom**
- **Steve Shellhammer, Qualcomm**
- **Marek Hajduczenia, ZTE**

Attendance – 1/17/13 Conf Call

- **Ed Boyd, Broadcom**
- **Mark Laubach, Broadcom**
- **Raanan Ivry, Widepass**
- **Bill Powell, Alcatel**
- **Duane Remein, Huawei**
- **Avi Kliger, Broadcom**
- **Christian Pietsch, Qualcomm**
- **Steve Shellhammer, Qualcomm**
- **Nicola Varanese, Qualcomm**
- **Marek Hajduczenia, ZTE**
- **Thushara Hewavithana, Intel**
- **Alan Brown, Aurora**

Attendance – 1/10/13 Conf Call

- **Ed Boyd, Broadcom**
- **Mark Laubach, Broadcom**
- **David Law, HP**
- **Raanan Ivry, Widepass**
- **Bill Powell, Alcatel**
- **Duane Remein, Huawei**
- **Avi Kliger, Broadcom**
- **Brian Kinnard, CommScope**
- **Christian Pietsch, Qualcomm**
- **Steve Shellhammer, Qualcomm**
- **Nicola Varanese, Qualcomm**
- **Joe Solomon, Comcast**
- **Marek Hajduczenia, ZTE**
- **Thushara Hewavithana, Intel**

Attendance – 12/20/12 Conf Call

- **Ed Boyd, Broadcom**
- **Hesham ElBakoury, Huawei**
- **Duane Remein, Huawei**
- **Steve Shellhammer, Qualcomm**
- **Nicola Varanese, Qualcomm**
- 2 unannounced callers

Attendance – 12/13/12 Conf Call

- **Avi Kliger, Broadcom**
- **Brian Kinnard, CommScope**
- **Christian Pietsch, Qualcomm**
- **Ed Boyd, Broadcom**
- **Mark Laubach, Broadcom**
- **Duane Remein, Huawei**
- **Steve Shellhammer, Qualcomm**
- **Nicola Varanese, Qualcomm**
- **Joe Solomon, Comcast**
- **Mike Peters, Sumitomo**
- **Charaf Hanna, ST Micro**

Attendance – 12/6/12 Conf Call

- **Avi Kliger, Broadcom**
- **Brian Kinnard, CommScope**
- **Christian Pietsch, Qualcomm**
- **Ed Boyd, Broadcom**
- **Mark Laubach, Broadcom**
- **Marek Hajduczenia, ZTE**
- **Duane Remein, Huawei**
- **Bill Powell, ALU**
- **Steve Shellhammer, Qualcomm**
- **Nicola Varanese, Qualcomm**
- **George Hart, Rogers**

Attendance – 11/29/12 Conf Call

- **Alan Brown, Aurora**
- **Brian Kinnard, CommScope**
- **Charaf Hanna, ST**
- **Christian Pietsch, Qualcomm**
- **Ed Boyd, Broadcom**
- **Curtis Knittle, CableLabs**
- **Leo Montreuil, Broadcom**
- **Mark Laubach, Broadcom**
- **Marek Hajduczenia, ZTE**
- **Duane Remein, Huawei**
- **Bill Powell, ALU**
- **Steve Shellhammer, Qualcomm**
- **Nicola Varanese, Qualcomm**
- **Hesham ElBakoury, Huawei**
- **Juan Montojo, Qualcomm**

OVERVIEW & TOPICS

Overview

- Objective
 - Define the process for the CLT PHY to connect to CNU PHY before the MAC is enabled.
 - Define any re-negotiation or PHY parameter procedure.
 - Define the PHY parameters to be configured over MDIO & Auto-Negotiation
 - What happens after CLT PHY & CNU PHY power up?
 - What parameters are PHY? (others are MAC)
- Output of the Ad Hoc
 - Baseline proposal
 - A single agreed solution is best.
 - Two or more options with pros and cons is the other option.
 - Joint Presentation for next meeting

Link Topics

- Link Transport Methods
 - Upstream
 - Downstream
 - e.g. Time Inserted or Frequency Inserted, or other
 - Protocol
- Auto-negotiation-Link state machine
 - Finding the Downstream
 - Speeding up the process
 - Initial Upstream
- Message Format & Addressing
 - e.g. Address + Register Pages
- Protocol
 - Dynamic or Static: Master or Slave, who makes change
 - e.g. Echo Protocol
- Parameters and Status Indicators
- MAC Discovery Compatibility

Parameters & Status Indicators

System Wide Possible

- TDD or FDD
- Power management control
- Note: Probing of the entire data channel would be handled in the MAC channel and not PHY link channel

Downstream Definition Possible List

- Number of Downstream OFDM channels
- 192MHz OFDM Channels Characteristics
 - Center Frequency, ~~Cyclic Prefix~~, FEC, Interleaver type/depth, ~~symbol length~~
- 192MHz OFDM Channels: Available Sub-Carrier (Frequency allocation)
- 192MHz OFDM Channels: Sub-Carrier Modulation Order

Upstream Definition Possible List

- Upstream PHY Link Channel frequency
- Number of Upstream OFDM channels
- 192MHz OFDM Channels Characteristics
 - Center Frequency, Cyclic Prefix, FEC, Interleaver type/depth, symbol length
- 192MHz OFDM Channels: Available Sub-Carrier (Frequency allocation)
- 192MHz OFDM Channels: Sub-Carrier Modulation Order
- Transmit Power Level
- Transmit Offset

Does not carry MAC Layer or above Frames (Configuration for upper layers could be carried)

Start Up Time Budget

- Finding the Downstream Channel
 - Hunt frequency and find preamble(Estimate at 2 seconds)
- Configuration for Downstream MAC channel
 - 1 second to transfer sub-carrier configuration

Evaluation Criteria

- Link establishment time.
- Simplicity
- Must work all of the time
- Must work below the MAC
- Bandwidth used

Definitions

- PLC – PHY Link Channel

LINK TRANSPORT

Link Transport Notes

- How many CNU are supported?
 - In general, this is a design specification issue but we need to size fields.
 - Fields should be 15 bits to match LLID size.
 - Practical Numbers for analysis: 256 CNU PHYs per CLT PHY. (8 LLIDs per CNU, what does really mean to the PHY?)
- Do we need a Link configuration on the CLT PHY for every CNU PHY?
 - Some parameters will be common but others will be unique.
 - If we have to specify transmit power, delay offset, etc; they would be unique.
- How wide is the frequency transport?
 - Broadcom Proposal: $32 \times 50\text{KHz} = 1600\text{KHz}$
 - ...
- How fast does it need to be? What is the data rate?
- How is the initial contention handled?
 - Broadcom Proposal: Random Symbol Offset or backoff a number of slot opportunities
- Do we need to detect collisions or just provide avoidance?
 - Broadcom Proposal: Avoidance
- How do we find the initial downstream channel?
 - Broadcom Proposal: Stored from previous position. Hunt based on 6MHz and/or 8MHz center frequencies.
- Do we need to acknowledge information from CLT PHY to CNU PHY?
- How fast do things change in the Network?
 - Updates in minutes.

Link Transport Notes

- How do we handle ingress noise on PHY link channel?
 - Double the channel
 - Move the channel
 - Avoid placing it on top of ingress, use clean spectrum, low modulation order. Only move if required.
- Do we define a grid position for the PHY link channel to simplify searching?
 - One location in a 24MHz channel? (Centered or first carriers or last carriers?)
 - One location in 6MHz and/or 8MHz channel grid? (Centered or first carriers or last carriers?)
 - One location in 2MHz channel grid? (Centered or first carriers or last carriers?)
- We need to define a fixed pattern (preamble) in the downstream PHY link channel
 - Can we use a CP instead of a preamble?
 - Fixed period?
- How do we transport multiple profile configurations if needed?
 - Option 1: Carry base profile in PHY link channel and bring up MAC with it. Use OAM to configure additional profiles.
 - Option 2: Configure all profiles in the PHY link channel.

Link Transport – Downstream Channel

- Two Options
 - Dedicated Subset of Carriers, Continuous
 - Subset of Carriers, periodic block of PHY link data
 - Spread out
 - Clumped
 - Symbol on all carriers
- How many PHY link channels do you need in the downstream?
 - 1 per 192 MHz
 - 1 for entire downstream
- How much data is needed in the channel?
- What is the modulation order for the PHY Link Data?
 - 16QAM is the most likely choice
- How much preamble is needed in the channel?
 - 1 symbol might work with auto-correlation
 - 2 symbols is simpler
- How many sub-carriers to make detection stable?
 - Channel model needed to be sure.
 - We can make a choice now but we will need to revisit
- We need to define a fixed pattern (preamble) in the downstream PHY link channel
 - Can we use a CP instead of a preamble?
 - Fixed period?

Link Transport – Downstream Data Rate

- Determine the required rate
 - Guessing the bandwidth of configuration of the modulation [channel worst case]
 - 4 channels (of 192MHz) x 16K carriers per block x byte per carrier = 64K Bytes
 - If initial configuration time of 1 second is required, then 64K Bytes needs 512Kbps
 - Double this so 1Mbps.
 - 1Mbps @ 16QAM is 256KHz
 - without overhead, 5 carriers at 4K FFT, 50KHz
 - 1% at 24MHz
 - Duane to expand on the analysis

Link Transport – # of Channels

- Do we want 1 PHY link of 1Mbps per 192 MHz channel downstream?
 - Is it a unique channel or just a duplicate if isolated channels?
 - Option 1: downstream is unique per 192MHz but upstream information would be the same if sharing the same upstream channel. All center Freq of downstream 192MHz blocks
 - Option 2: Duplicate entire PHY link so a multiple channel only needs to listen to 1 for all information
 - Option 3: Single PHY Link channel. Any lower capabilities CNU must listen to common channel that carries the PHY Link channel.
 - The decision for 1 per 192MHz or 1 per downstream can be linked to the decision on required CNU channel support. The PLC must follow this decision.
- Do we want 1 PHY link of ?Mbps per ? MHz channel upstream?
 - For TDD, upstream and downstream channel count would likely be the same.
 - Multiple PHY Link channels will use 2 transmitters out of the limit
 - Number of transmitters limit will grow as channel size increases?

Straw Poll #1

- Should the downstream PHY link channel be a fixed modulation order (e.g. QPSK, 16QAM, 64QAM)?
- Y: 27
- N: 1
- Abstain: 7

Straw Poll #2

- The PHY Link Channel should use 16QAM Modulation order?
- Y: 11
- N: 0
- Abstain: 0

Straw Poll #3

- The PHY Link Channel should use the same CP size and symbol duration as the data channel?
- Y: 11
- N: 0
- Abstain: 0

Straw Poll #4

- A CNU will auto-detect the CP size and sub-carrier spacing (symbol duration) of the downstream PHY Link Channel [Not provisioned at CNU]
- Y: 12
- N: 0
- Abstain: 0

Straw Poll #5

- The downstream PHY link channel should be a dedicated set of carriers in every downstream symbol (isolated from MAC data).
- Y: 13
- N: 0
- Abstain: 8

Motion #3

- The Downstream PHY Link Channel shall use a fixed modulation order of 16 QAM to carry PHY link information.

- Mover: Ed Boyd
- Seconder: Kevin Noll

- Y: 39
- N: 0
- Abstain: 0

- Technical Motion $\geq 75\%$

Motion #4

- A CNU shall auto-detect the CP size and sub-carrier spacing of the downstream PHY Link Channel
- Y: 40
- N: 0
- Abstain: 0
- Mover: Ed Boyd
- Seconder: Juan Montojo
- Technical Motion $\geq 75\%$

Motion #5

- The Downstream PHY Link Channel shall use the same CP size and symbol duration as the data channel.
- Y: 42
- N: 0
- Abstain: 0
- Mover: Ed Boyd
- Seconder: Eugene Dai
- Technical Motion $\geq 75\%$

Straw Poll #6

PHY-Link register

I think that the read/write capability of all/nearly all CNU PHY registers should be the same between the PHY-Link (from CLT) and MDIO (from CNU)

Yes	__ 4 __
No, some	_____
No, None	__ 1 __
Abstain	__ 3 __

Downstream PHY Link Channel

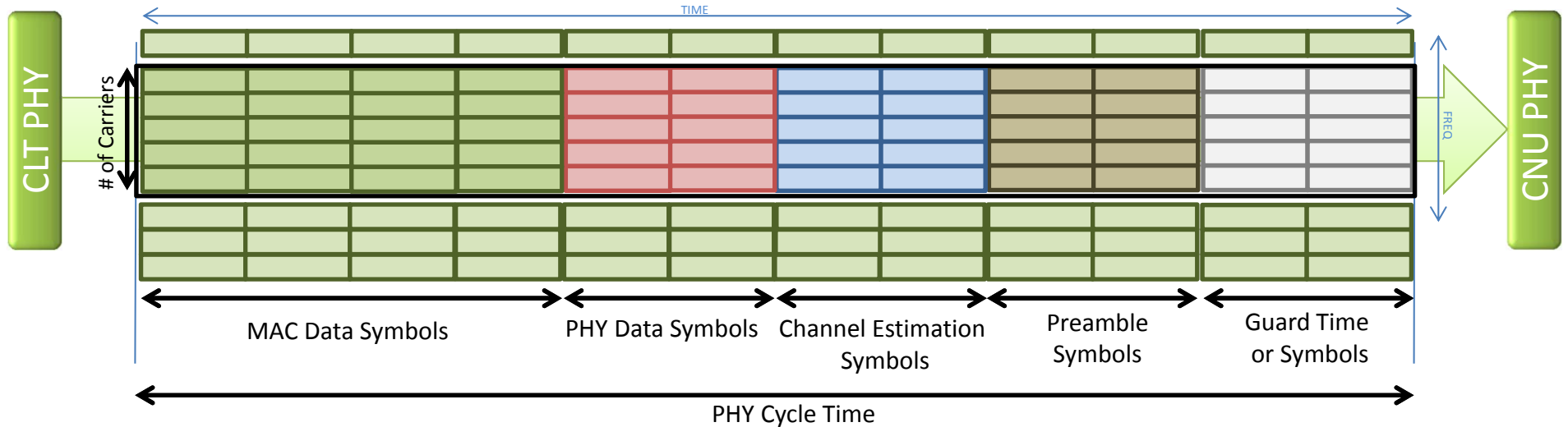

	Bounds	Option 1 - FDD	Option 2 - FDD	Option 1 - TDD	Option 2 - TDD
PHY Link Channel Width (# of Carriers x carrier width)	1 to	300KHz	400KHz (easier to find)		
Guard Time/Symbols	0 to	0	0 to X	RTT+SwitchTime + up-cycle	?
Preamble Symbols	1 to	2	4		
Channel Estimation Symbols	0 to	?	?		
PHY Data Symbols	1 to	?	1 to Z		
MAC Data Symbols	0 to	0	>0		
PHY Data Rate	>0				

Downstream PHY Link Channel

- Number of preambles of symbols?
 - Fixed pattern, BPSK, PN sequence is an example
 - 2 symbols is used in LTE
 - 2 maybe difficult to detect in bad SNR, 8 would be able to support bad SNR
 - Avi simulation results show 8 symbols has high detection rate
 - Avi will show presentation on results at the next meeting
- How often should preamble be repeated?
 - Every 128 symbols, 8 preamble symbols (1/16th of PHY link channel) [Avi]
 - Every
- Channel Width
 - 400KHz gives more room for overhead
- Sharing the PHY link carrier with the MAC layer Data
 - Wider Channel can be used if MAC data is included.
 - Wider Channel is better against fading
 - PHY link alone doesn't restrict the MAC data channel
 - Slightly variable on the MAC data channel with the gap
 - Simpler to have an isolated channel

Downstream PHY Link Channel

- Do we need to detect symbol size (sub-carrier spacing) and CP size of PHY Link Channel?
 - Fixed is simpler but is it too restrictive and should be same.
 - It is not desirable for the data and the PLC to have different symbol size. Same FFT.
 - The PHY link CP and symbol size should be detected.
 - If we have 2 symbol sizes supported in the data channel, the PHY link channel will have 2 possible sizes.
 - The size of the PLC is constant (e.g. 400KHz)
 - 400KHz would be 8x50KHz carriers
 - 400KHz would be 16x25KHz carriers
- Cycle Size of PLC
 - Could be a configured size.
 - The maximum period will be defined so the searching time is known
 - The minimum period will be related to the frame alignment indication
- PLC preamble start relative to data channel frame alignment indication
 - The PLC position could be used to identify a known position in the downstream cycle for TDD.
 - In FDD, the PLC position could be aligned with pilot rotation

Earlier Presentations on Link

REFERENCE MATERIALS

Presentation from Conference Call

FEB 7, 2013 GENEVA

PHY Configuration

RF Channel Definition

PHY-OLink Spectrum Ad Hoc

Ed Boyd

Duane Remein

Configuring the RF Channel

- At the CLT
 - Both US and DS RF Channel(s) parameters are configured via MDIO
 - Center Frequency
 - High/Low/Mid Exclusion Bands
 - US PHY-Link location & width
- At the CNU
 - Discovered via correlation
 - DS Center Frequency of Primary RF Channel
 - DS PHY-Link (width is defined by standard?)
 - Configured via Primary PHY-Link
 - DS High/Low/Mid Exclusion Bands
 - DS Center Frequency of any Secondary RF Channels
 - US Center Frequency
 - US High/Low/Mid Exclusion Bands
 - US PHY-Link location & width

EB1

EB2

D1

EB4

EB3

EB8

EB5

EB6

EB7

Slide 57

- EB1** Exclusion Band Start Carrier Number and Count
Edward Boyd, 1/30/2013
- EB2** Downstream PHY Link Location is needed as well.
Edward Boyd, 1/30/2013
- EB3** The PHY Link Channel should configure this parameter.
Edward Boyd, 1/30/2013
- EB4** This is a hunting procedure.
Edward Boyd, 1/30/2013
- EB5** What is primary. I would say remotely configured via PHY Link Channel.
Edward Boyd, 1/30/2013
- EB6** DS Frequency of all RF Channels
Edward Boyd, 1/30/2013
- EB7** I'm not sure about width. US PHY Link Channel Definition
Edward Boyd, 1/30/2013
- EB8** I think that it will be a fixed width but we haven't passed a motion on it yet.
Edward Boyd, 1/30/2013
- D1** I think the DS PHY-Link (at least in the primary RF channel should be defined by standard or discovered. I agree that it wouldn't hurt to reinforce it via configuration.
D00725987, 2/5/2013

Options

- Any CNU PHY register that can be read/set via MDIO can be:
 - read at the CLT via the PHY-Link
 - set by the CLT via the PHY-Link
- Any CNU PHY register that can be read/set at/by the CLT via the PHY-Link can be read/set via MDIO
 - Can limit the registers set via PHY-Link

Configuring the EPoC PHY(s)

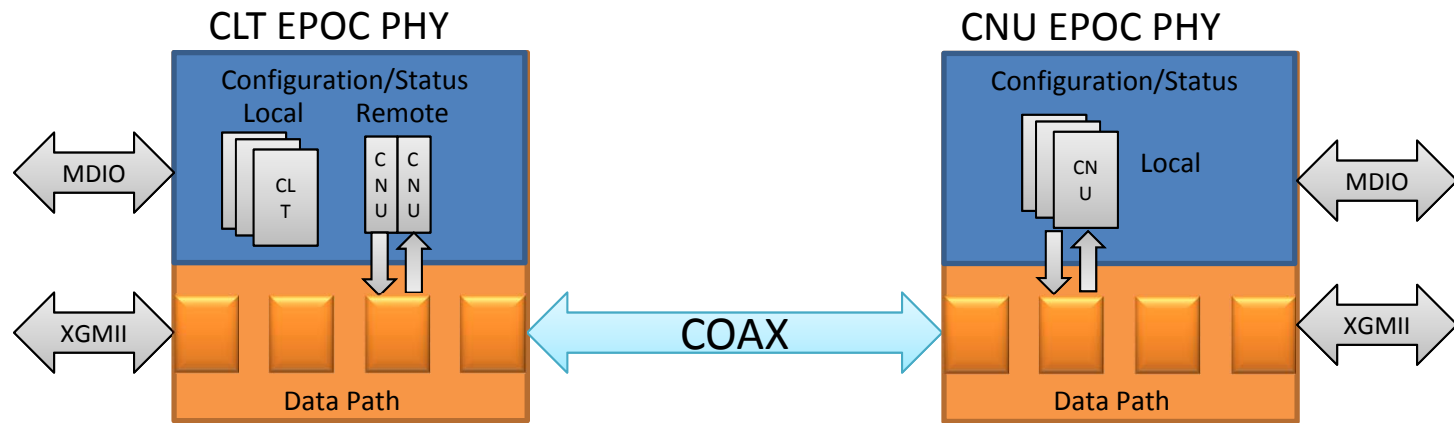

- At the CLT
 - MDIO provides access to CLT PHY registers for configuration and status.
 - MDIO provides access to remote CNU PHY registers for configuration and status via the PHY Link Channel (with echo).
- At the CNU
 - MDIO provides access to CNU PHY registers for configuration and status.
 - PHY Link Channel provides CLT remote access to CNU PHY registers for configuration and status.
 - For simplicity, all CNU register pages could be accessible by both methods.
 - CNU does not have remote access to CLT PHY registers.

D2

D3

Slide 59

- D2** I don't think Echo is the right term here. Reading back a register is not an Echo (unless your propossing the in order to read a register the CLT must write it, which I doubt).
D00725987, 2/5/2013
- D3** This may be obvious but it doesn't hurt to be explicit.
D00725987, 2/5/2013
- D4** Moved to location of original slide on this topic.
D00725987, 2/5/2013

PHY-Link register

Straw Poll #10

- I think that the read/write capability of all/nearly all CNU PHY registers should be the same between the PHY-Link (from CLT) and MDIO (from CNU)

Yes	__ 4 __
No, some	_____
No, None	__ 1 __
Abstain	__ 3 __

PHY-Link register

Straw Poll #11

- I think that any CNU PHY register that can be read/set at/by the CLT via the PHY-Link can be read/set via MDIO.

Yes _____

No _____

EB9

Slide 61

EB9

This seems obvious to me. The CNU must know what was set by the CLT.

Edward Boyd, 1/30/2013

Presentation from September IEEE Meeting

SEPT 2012 GENEVA

EPoC PHY Link and Auto-Negotiation

Ed Boyd, Broadcom

Avi Kliger, Broadcom

Marek Hajduczenia, ZTE (Supporter)

Overview & Goals

- This presentation continues the PHY Link & Auto-Negotiation topic from the technical feasibility presentation in Hawaii.
- Like other Ethernet copper PHYs, the EPoC PHY requires a link state machine to configure the PHY before the Ethernet MAC can be enabled.
- The Link process should not require additional signals between the MAC and PHY.
- The Link process should not require EPoC specific changes to the MAC layer.
- The Link process should be very simple and should not require decoding higher layer packets or a complex MAC in the PHY.

What is Auto-Negotiation and PHY Link?

- Auto-negotiation is a way for 2 PHY's to establish connectivity before the MAC layer has been enabled. (>2 in EPoC)
- A PHY will start out "Unlinked" with the MAC disabled.
- A PHY that has finished auto-negotiation is considered "Linked"
- PHYs will periodically send and receive Link Information.
- If a PHY does not receive Link Information over a time period, it will leave the Linked state and re-start auto-negotiation.
- PHY Link information is a set of configuration parameters sent between the PHYs.
 - PHYs are configured with this information through the MDIO.
- PHY Link information has traditionally been in pages of configuration bits and status indicators.

EPoC Link Information Items

- Sub-Carrier Configuration
 - Location in spectrum, usable/nulled, and modulation order for the carriers in the upstream and downstream.
- Transmit Power Level
- Symbol Alignment Timing Offset
 - Fixed delay offset so upstream symbols are aligned
- Possible PHY Configurations & Capabilities
 - Interleaver Depth/Enable, FEC Type/Size/Enable, Scrambling Enable, etc
- Possible Status Indicators
 - Link State, Rx Power Level, Error Indication, etc
- Possible Future Extensions or Vendor Extensions
 - Power Saving control, link protection, etc

Link Transport Options

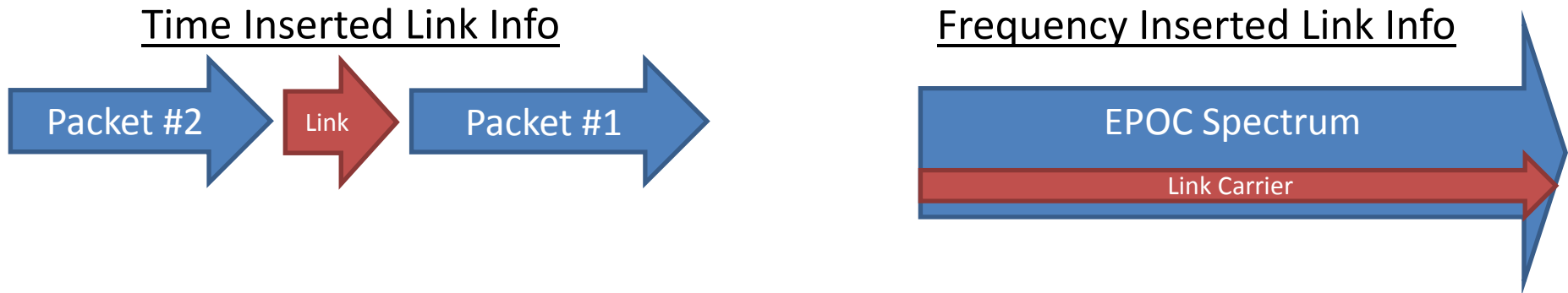

- Time Inserted Link Info (Between Packets)
 - Traditionally, Link Info (pulses) have been transported in the IPG.
 - Downstream is challenged by long symbols and streaming FEC so IPG is not possible.
 - Downstream insertion between symbols is possible but complicated.
 - Upstream between symbols or packets would be very difficult without MAC slots.
- Frequency Inserted Link Info (Dedicated Sub-Carriers)
 - A small number of carriers would be dedicated to carry link information.
 - Easy to have a high SNR modulation order for reliability.
 - Coordination with Ethernet MAC for upstream transmission is not required
 - Easier to find and lock onto at discovery.

Frequency Inserted Link Info will be the focus of this proposal

Link Information Addressing

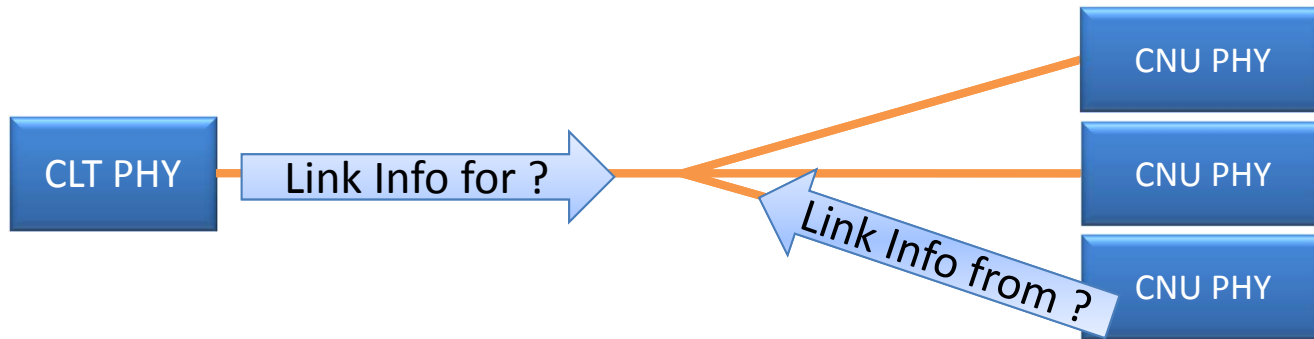

- Point-to-Multipoint Requires an address
 - Traditionally Link Information has been sent on point-to-point network so the source and destination is clear.
 - In the case of EPOC, the CLT needs to send information to a particular CNU.
 - The CLT also needs to know the source of link information that it received.
- What is the address?
 - The address should be the first field in the link information.
 - It can be configured in the PHY through the MDIO
 - The Ethernet MAC address is a possible choice
 - The LLID can't be used since auto-negotiation happens before MAC layer discovery.

Echo Protocol

- Shared Upstream
 - Access to the shared upstream can be simple with an echo protocol.
 - The CLT PHY will simply send the Link Information to the CNU PHY and the CNU PHY will respond with the same message in a fixed time later.
 - A downstream time reference (i.e. MPCP timing from the MAC), GATE frames, etc are not required.
 - The Echo protocol also provides an acknowledge function to the CLT PHY.
- Broadcast Echo
 - Using a broadcast address on the link information allows for a new CNU PHY to be configured.
 - A CNU PHY that has not reached the Linked state, would respond to a Broadcast Echo
 - A random back off in time or Broadcast Echo opportunities should be considered to resolve contention.

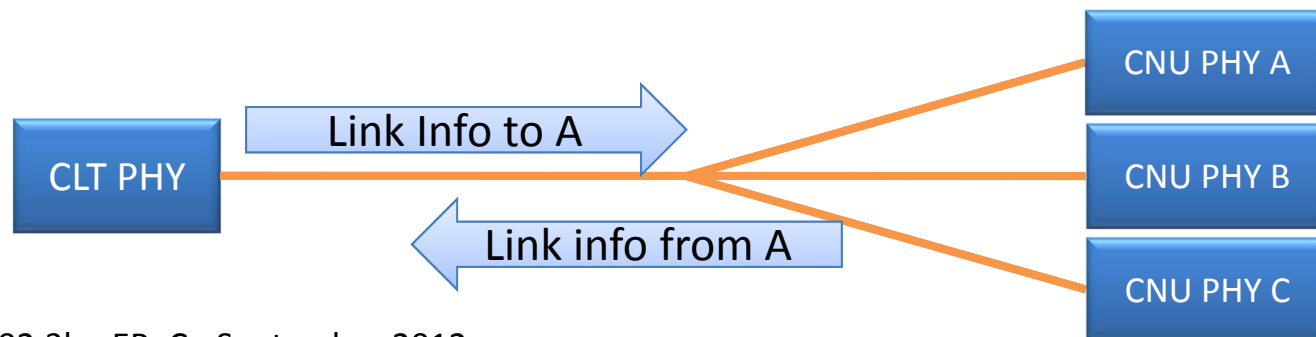

Rotating Link Carrier

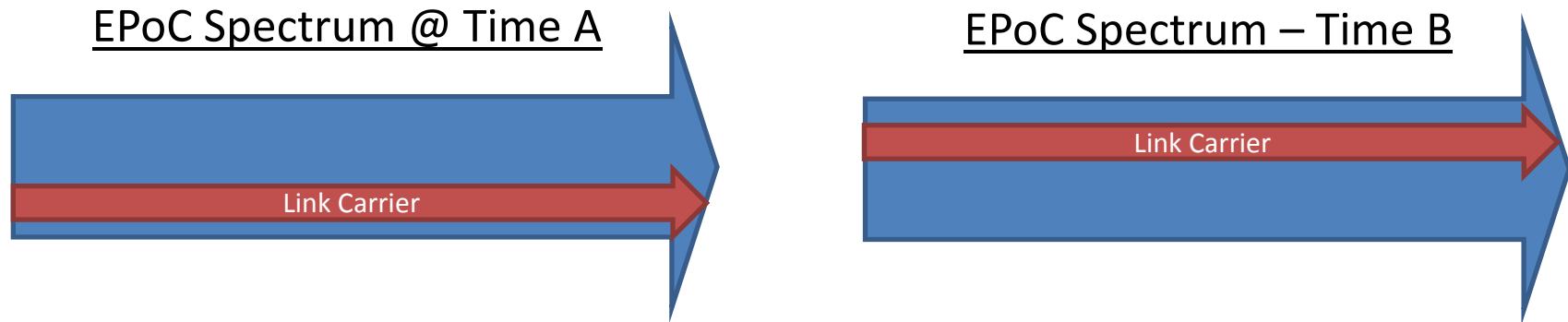

- EPoC Link Carrier could be moved to different carriers periodically so CNU's with interference can register.
- Rotated Link carrier might be used to measure performance or other parameter on all carriers.
- Rotated Link carrier could be applied to upstream or downstream.

Symbol Alignment Example

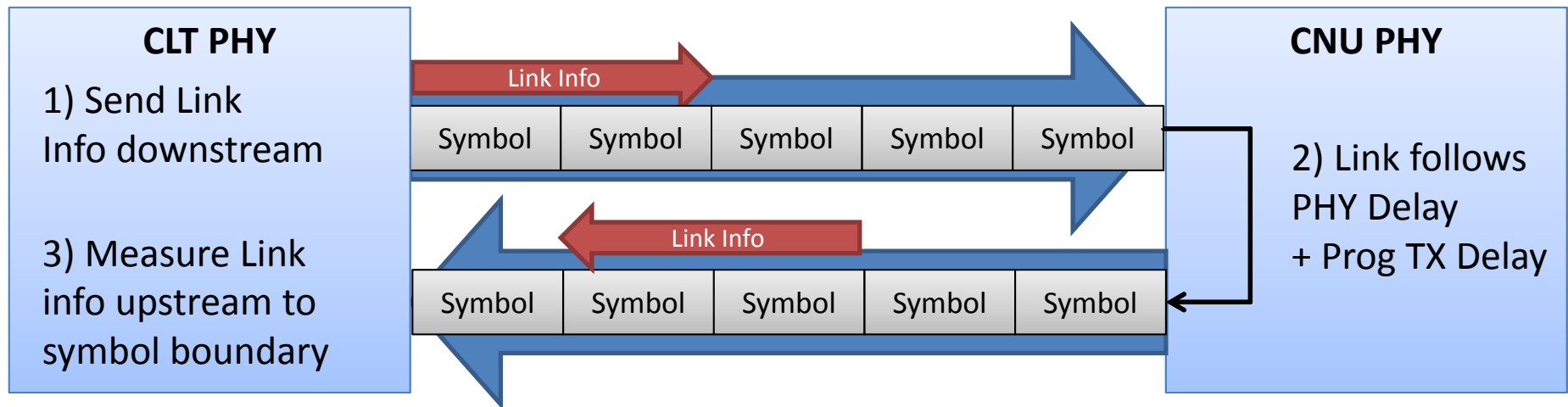

- CLT PHY needs to align upstream symbols from all CNU PHYs
- MAC grant time selects symbol and carriers in symbol.
- Link Information echo could be used to determine programmable transmit delay.
- Link Information could set value for programmable transmit delay.
- Simple example shows equal upstream and downstream symbols but different sizes could work.

Link Up Process

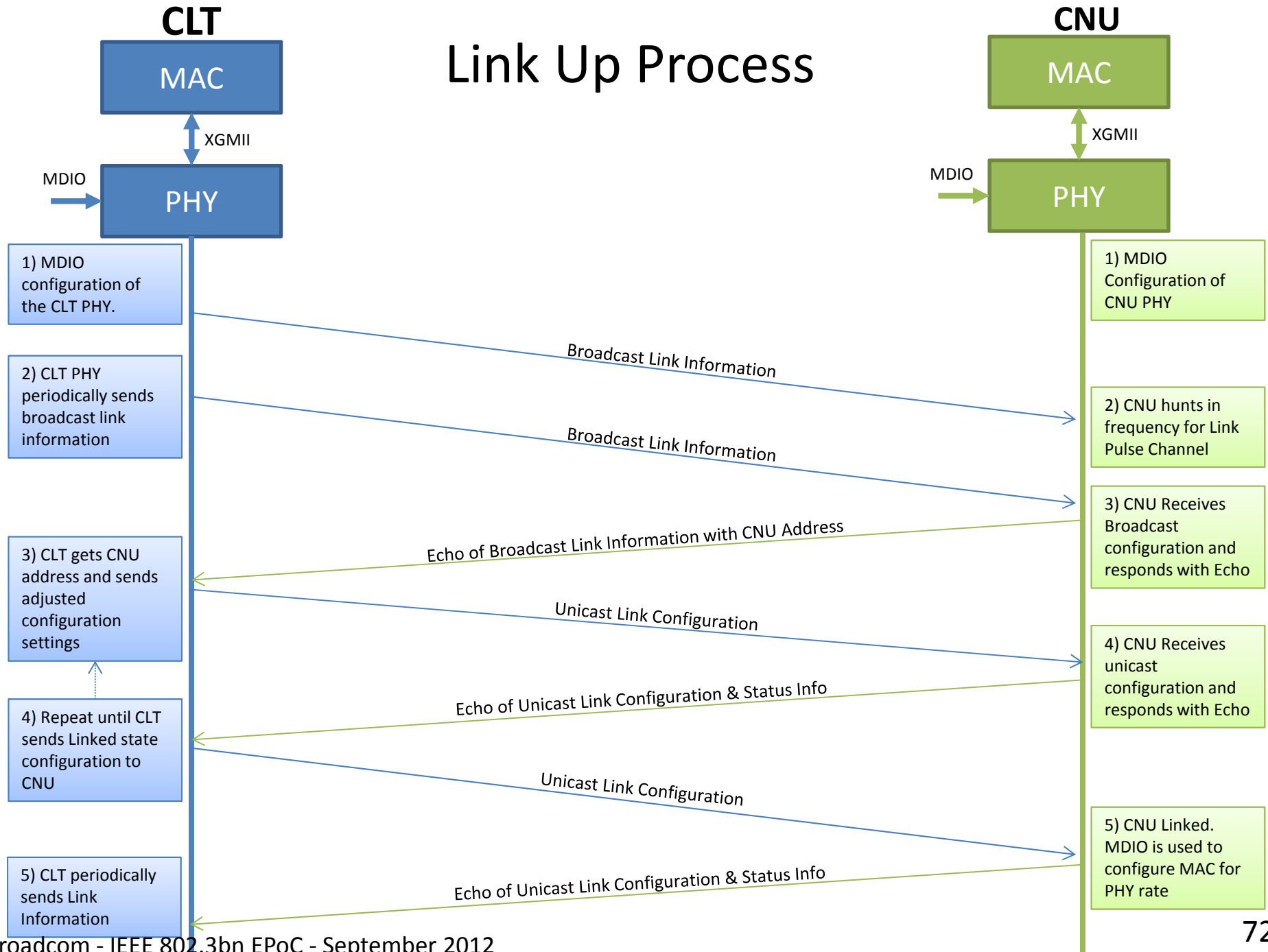

Summary

- EPoC requires auto-negotiation for the PHY configuration.
- Addressing is required in a Point-to-Multipoint topology.
- Dedicated Carriers make an easy transport for link information.
- The Echo protocol is a simple solution that doesn't require new MAC signals or any MAC changes.
- We should form an ad hoc group to work on baseline proposal for PHY Link procedure.

Presentation from Link Ad Hoc Call

OCT 4, 2012 CONFERENCE CALL



Implications of PHY Initialization Procedures

Qualcomm – 11 October 2012

PHY Control Channel and Procedures /1

- Need for PHY Control Channel: conveying L1 control information, e.g.
 - Downstream: bit-loading profiles for DS and US
 - Upstream: supported bit-loading profile in DS for a specific CNU
- Coordinated PHY initialization and MPCP registration
 - MPCP is aware of start time of OFDM symbols (PHY framing)
 - Only way to enable bit-loading in US
 - Could use 1D-to-2D map to perform frequency-aware US resource allocation
 - Could use extended MPCP gate message to perform frequency-aware US resource allocation
 - Requires some interaction between MAC and PHY
 - Extensions to MAC/PHY interface ? (additional synch procedure between MAC and PHY)
 - Additional MDIO communication ? (MAC needs to be aware of bit-loading maps)

PHY Control Channel and Procedures /2

- Need for PHY Control Channel: conveying L1 control information, e.g.
 - Downstream: bit-loading profiles for DS and US
 - Upstream: supported bit-loading profile in DS for a specific CNU
- Independent PHY initialization and MPCP registration
 - OFDM symbols and MPCP timing are not aligned
 - This prevents from using bit loading in US: data rate supported by each CNU depends on the frequency resources used to transport its frames
 - This choice forces to use either a single MCS for each CNU or a single MCS for the whole plant
 - In fact, only in this way each CNU would support a fixed data rate no matter on which frequencies its packets are transmitted

The way we do PHY initialization and MPCP registration has a dramatic impact on US system design and MAC/PHY interface !!!

Presentation from Link Ad Hoc Call

OCT 18, 2012 CONFERENCE CALL

Link setup BELOW the MAC

Ideas to noddle on from 3GPP
protocol layering
PDP/RLC(channels)/MAC/PLL/PHY

Up and running ?

- How do you establish physical link between CLT and CNU when there are various MCS channels and various MCS per CLT network (domain)?

Assumptions/Limits/Goals

- How do you do so within the limits (goals) set by the project to not modify the MAC and add as little as possible to MPCP (sublayer) ? Continue to assume no buffer in CLT.

Related challenges

- a) initial capabilities determination (either discovery or configuration)
- b) conveying data rate capability northbound
- c) adjusting capabilities if channels or added or if conditions change (rate of change being relatively slow compared to wireless for example). But how “real time” do (a) and (b) need to happen ? If it isn’t fast enough and rates are reduced, obviously frames can be dropped because there is no buffer in the CLT.

Statement and Overview

- Statement

The objective (here) is not to explain entirely why or how wireless protocols are layered the way they are or how they work. Some of the logic may be for history or backwards compatible reasons, etc.

- Overview

- Ad Hoc Link objective/problem statement
- Shared (common) problems to be solved
- Obviously not exactly the same (what are the differences)
- 3GPP
 - 3GPP in 20 seconds
 - 2 Transport: SMS/MMS/OMA (datagrams) and PDP tunnels
- Layering in 3GPP PDP
- Relationship of transports to various link layers and MAC
- Ideas for EPoC from 3GPP

- Physical Link Control

- Where
- Hidden layers
- PLC “setup”
- Recommendations

Shared Problems to be Solved

- Global market has different frequency needs, regulations, etc. around the world
- Desire for single 'standard' and single product that works globally
- Varying quality of transmission medium (air/copper)
- Ingressors abound in timescales from perpetual (broadcasters) to persistent to impulse
- History of similar modulation techniques (QPSK, QAM, OFDM, TDMA, OFDMA, SCDMA, etc.) – although notably wireless has always led the way. Of late: OFDM (DS) / OFDMA (US) (look familiar ?)
- Support for both FDD and TDD (Radio resource control isolated from bearer)
- Near/Far (hidden stations); SNR; and other identical problems
- P2MP – aka Many to one; broadcast/multicast and virtual or secured unicast
- Complex P2MP scheduling with changing data rates.
- Similar usage patterns (DS:US ratio), endless demand
- So similar, it's actually competing for customers using exactly the same services – but that's another story

Not Exactly the Same

- Unlike wireless, EPoC:
 - Does not have to contend with legacy CPE
 - Fading and other mobile affects obviously not present
 - No mimo and no synchronous broadcast from multiple sources (...Strict synchronous functions are not necessary)
 - The time-basis of changes (moves, adds, changes) is on the order of days (not seconds as in wireless)
- So we will not talk about features and functions (in particular specific channels) designed to handle those challenges, instead we will look at the channels used primarily for initial setup and channels used for managing channel assignments

3GPP in 20 seconds

- standards organization for GSM (AT&T & TMO in US)
- developed (for GSM) GPRS which was later adopted by 3GPP2 (sister organization for IMT-2000 and its children CDMA/WCDMA)
- developed LTE, the successor to GSM which still uses the GPRS based architecture
- today, both CDMA and GSM operators with mixed LTE have combined/converged cores that support the GPRS based model for Packet Data Protocol (PDP) transport

Long story short, all cellular wireless
utilize PDP model today

2 Transports

- There are classically two transport systems within cellular. These are the circuit switched (CS) and packet switched (PS) domains. Within each or combined between the two are both signaling and the bearer networks. The signaling network was co-opted to be a bearer network as well, for messaging (at first SMS, then MMS, and now of course OMA which integrated the latter two and datagram based transport for IP that doesn't require bearer "setup". Both are shown here in this WCDMA example.

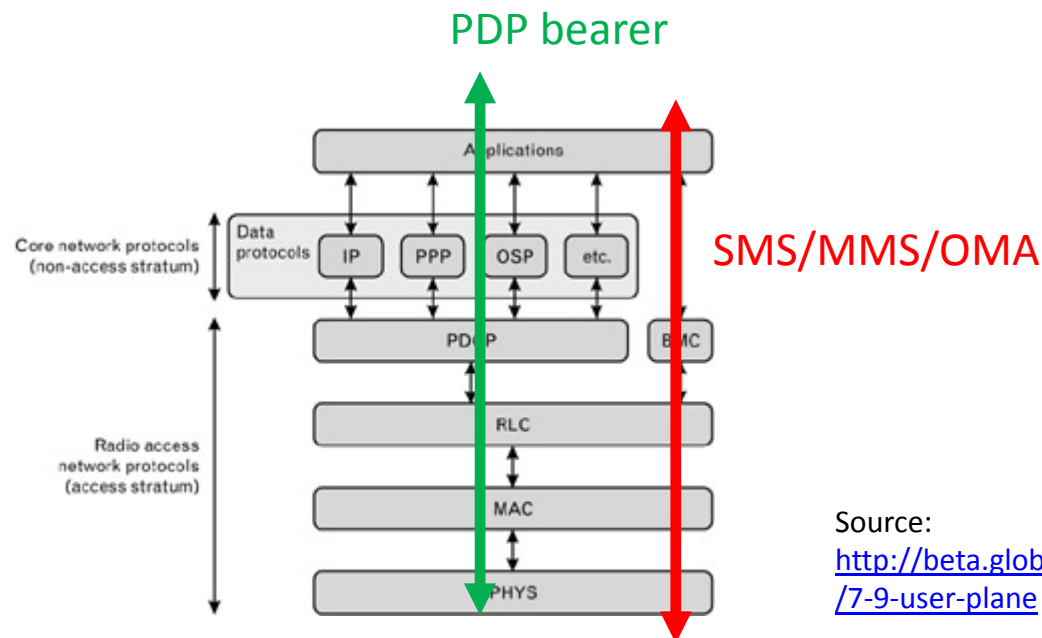

Source:

<http://beta.globalspec.com/reference/65882/203279/7-9-user-plane>

- We will look only at the PS domain, and within it the layering to provide the Packet Data Protocol (PDP) PS bearer.

LTE non-message bearer (PDP)

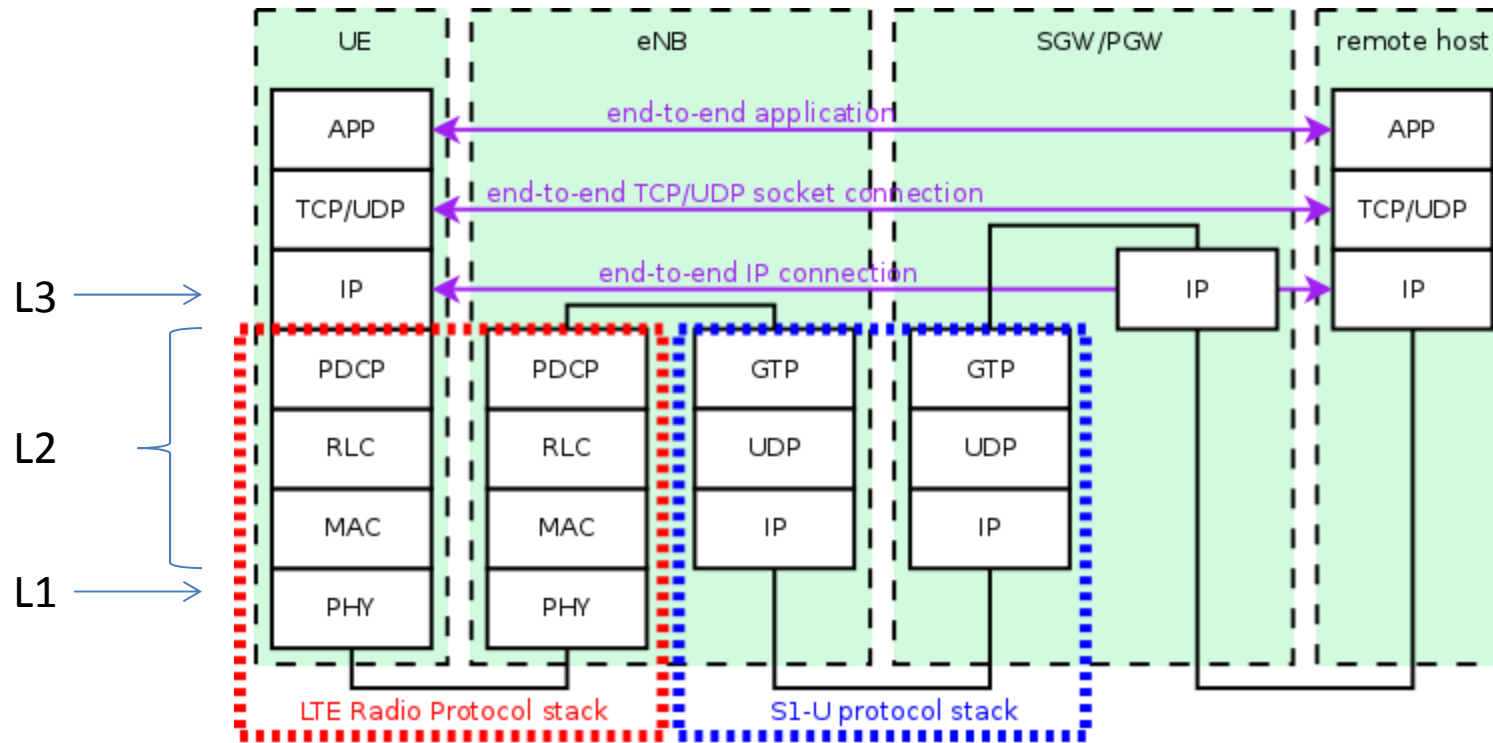

Source: <http://www.nsnam.org/docs/models/html/lte-design.html>

Other variations use GRE/PPP/IPsec for one or another of PDP bearer or signaling. Important point is that while there are many layers, PDP looks like a link layer to the OSI network layer. That's what I'd like us to look at.

RLC function

Here PDP is depicted as a link layer even though it resides far above the MAC. You can think of each PDP context as analogous (for example) to a DOCSIS service flow (SF).

I'm not suggesting we do this as shown, bear with me ...

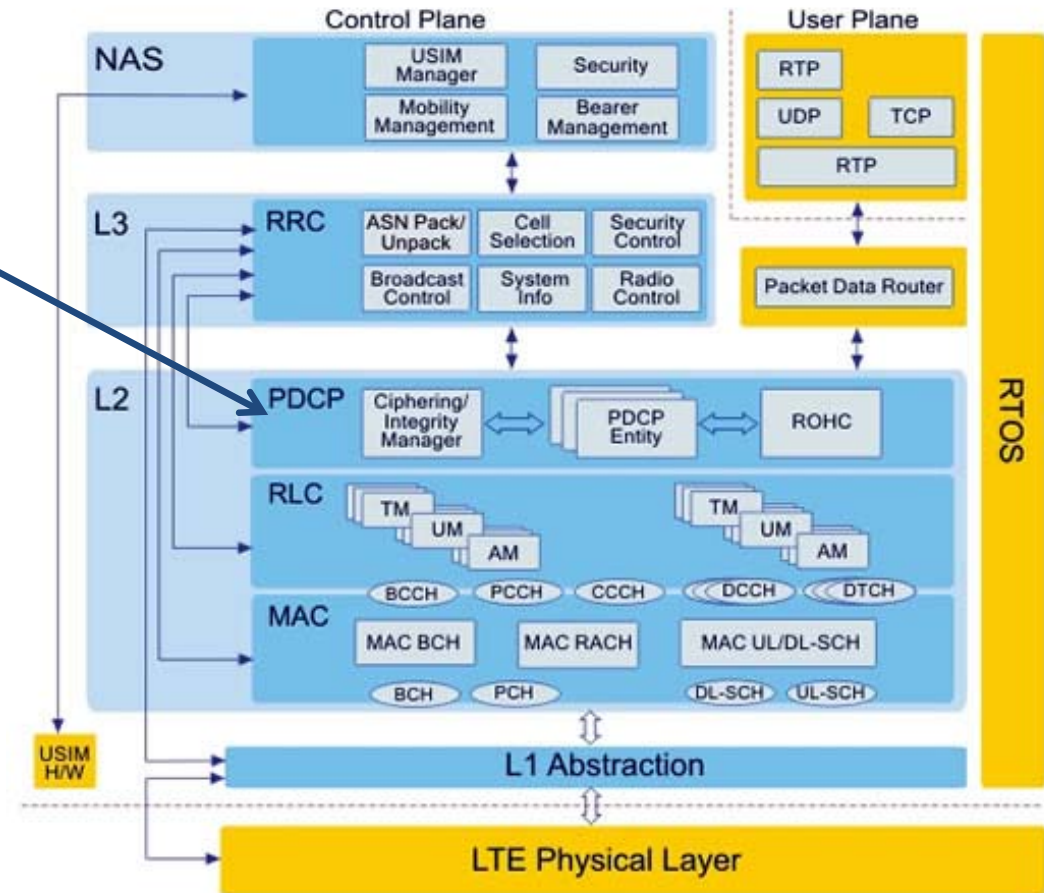

Source: Rhode and Schwarz

(apologize that I don't recall which R/S document this came from).

DL Signaling in PHY (PBCH)

Cell acquisition signalling



- Synchronisation signals in subframes 0 and 5 of each 10 ms radio frame
 - Used in initial cell search

- Physical broadcast channel (PBCH) in subframe 0 of each radio frame
 - Carries the Master Information Block (MIB)
 - Includes indication of system bandwidth
 - Robust design for cell-wide coverage:
 - Low rate, QPSK, robust channel coding (1/3-rate tail-biting convolutional code with repetition), 40 ms TTI
 - CRC indicates number of transmit antennas

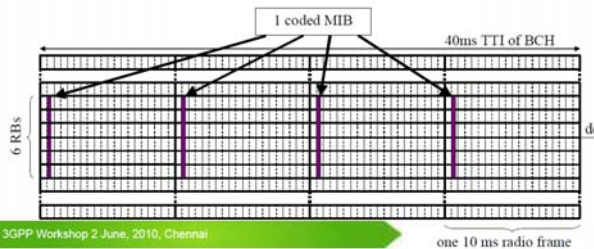

3GPP Workshop 2 June, 2010, Chennai

one 10 ms radio frame

Downlink Channel Structure



- Flexible control design to avoid unnecessary overhead
 - Control region is first 1-3 OFDM symbols in each subframe (2-4 in narrow bandwidths)
 - Control region size (CFI: control channel format indicator) is dynamically variable
- Data transmission on Physical Downlink Shared Channel (PDSCH)

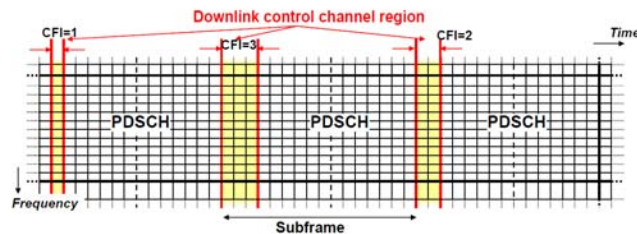

Modes ...

PDSCH transmission modes



- In Rel-9, each UE is configured in one of 8 "transmission modes" for PDSCH reception:

- Mode 1: Single antenna port, port 0
- Mode 2: Transmit diversity
- Mode 3: Large-delay CDD
- Mode 4: Closed-loop spatial multiplexing
- Mode 5: MU-MIMO
- Mode 6: Closed-loop spatial multiplexing, single layer
- Mode 7: Single antenna port, UE-specific RS (port 5)
- Mode 8 (new in Rel-9): Single or dual-layer transmission with UE-specific RS (ports 7 and/or 8)

- (in each case, transmit diversity is also available as a fallback)

Location of control signaling ...

Downlink control signaling



- Physical Control Format Indicator Channel (PCFICH) indicates the control region size (CFI)

- Located in first OFDM symbol of each subframe
- PCFICH is designed to be robust
 - 16 QPSK symbols transmitted with full frequency diversity

- Physical Downlink Control Channel (PDCCH) carries Downlink Control Information (DCI) messages:

- downlink resource assignments
- uplink resource grants
- uplink power control commands

- Physical Hybrid ARQ Indicator Channel (PHICH) carries ACK/NACK for UL data transmissions

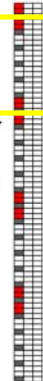

Ideas for EPoC from 3GPP

- Accommodate various MCS (TDD, FDD and frequency plans)
- DL Broadcast matrix on symbols for client channel use (modes in 3GPP)
- Random access UL channel
- Hidden layers (we already use this)
- Physical Channel “Indicator” provide signaling to higher layers

Layering in 3GPP

- Two ways to look at 3GPP layering:
- Look at the labels:
 - PDP (carries GTP) is below the network but above the LLC. Kinda like MPLS, a tunnel logical link forwarder
 - RLC is LLC
 - MAC is MAC
 - PLL is new, we don't have this in 802
- Look at the functions:
 - IP is network (Layer 3)
 - PDP is LLC (Layer 2)
 - RLC is multiplexing layer (like DOCSIS channel bonding M-PPP/L2TP)
 - MAC SCH within MAC is like MPCP
 - PLL is obviously below the MAC
- For our purposes, two areas of interest to learn from
 - 1) Link Control
 - 1) Looking at the PDP as if it were LLC, what we see below it is a link control layer (RLC) with possible **lessons to learn regarding fixed use of resources within a logical channel (and underlying physical channel) to create permanent logical-logical channels for physical link layer resource management and control (channel selection, etc.)**.
 - 2) PHY Control
 - 1) Looking at the MAC-SCH/PLL what we see is a **mechanism for signaling PHY information to higher layers (indicators)**
 - 2) **Predetermined symbols broadcast frames at well-known (time referenced by prefix) 'locations' include matrix of information. That information (MIB) further contains supported modes, etc.**

Learning from 3GPP

- SIB/MIB video

[http://www.youtube.com/watch?v= P4j5Kn8
HCc](http://www.youtube.com/watch?v=P4j5Kn8HCc)

- 3GPP Specifications

- R&S [http://www2.rohde-
schwarz.com/file_17282/1MA191_0E.pdf](http://www2.rohde-schwarz.com/file_17282/1MA191_0E.pdf)

Physical Link Control (PLC): Where

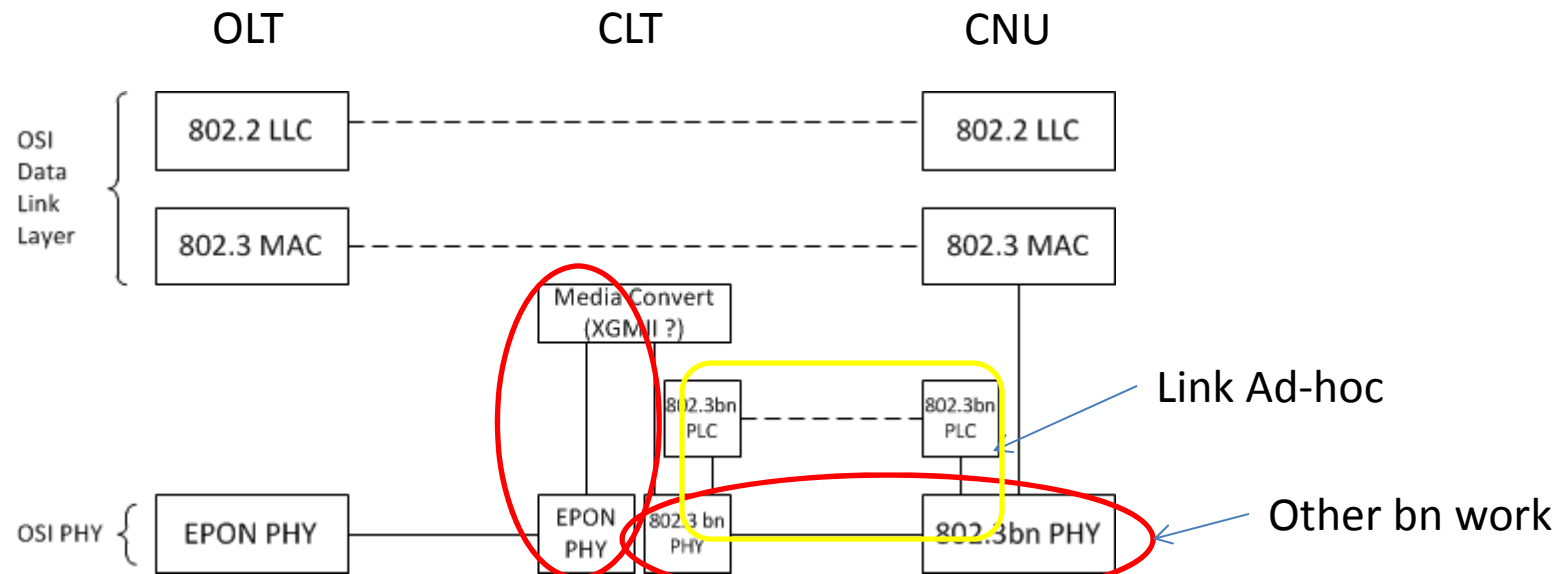

- PLC probably does not need to communication with the media converter US
- CLT has integral ONU to receive EOAM from OLT to setup profiles
- CLT originates profile broadcasts directly to PLC
- CNU knows which profiles to use and begins using them PHY without PLC response
- Summary: PLC is one way (broadcast) CLT-> CNU phy link to be used to setup channels.

Closer Look at the Hidden layers

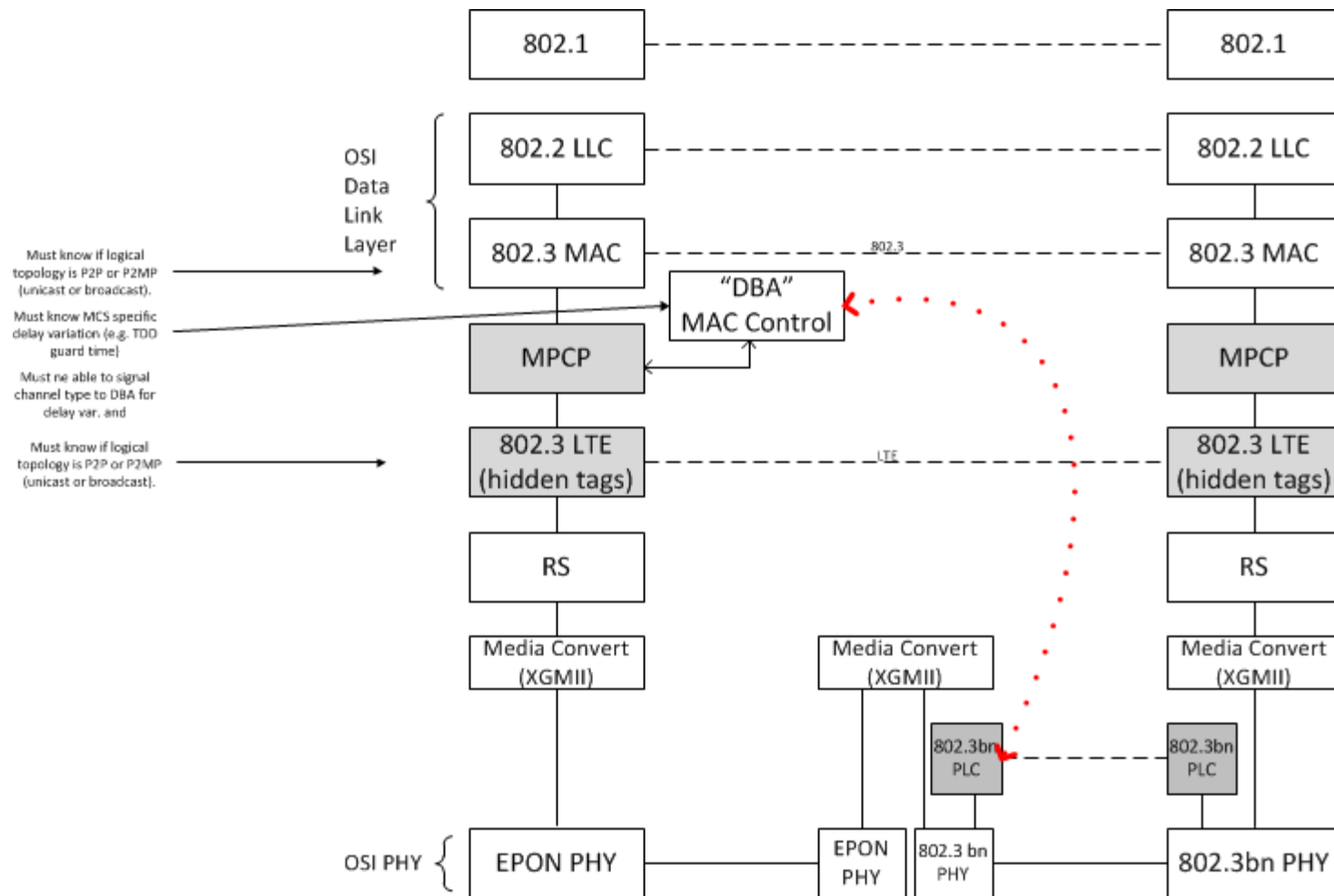

“Link” Setup

- Establish the concept of Physical Link Layer or Physical Link Control (PLC)
- Physical Link Control
 - Modeled in part after PRACH (async initial setup) and in part after PBCH (which carries master block or MIB)
 - DS: Supports only fixed length frames of specific types
 - Announce: broadcast profiles (both DS and US)
 - ACK channel ?
 - data rate can be low
 - operate on LCD frequency/modulation. All CLTs and CNU must support this
 - not visible to the MAC, there is no data path transmission over PRACH CLT broadcasts ‘MCSes’ (These are called “modes” in 3GPP, I prefer to call them profiles see below).
 - Requires either regular broadcasts for new stations (CNU) to find
 - Probably forced
 - US requires further discussion
 - If CNU are only going to support a subset of profiles, does it matter which ones ? They really don’t need to respond to DS PLC, just use it. Ex:
 - If A B C D E are available, but administrative PLC only offers A C E, then we just say CNU MUST NOT use B or D. Let’s say then that CNU uses A or C or both. It does not HAVE to tell the CLT over “PLC” because when it begins transmitting on A and/or C, CLT will know
 - Options (I don’t think these are needed)
 - Could require CNU to transmit ack type pdu on A or C across PHY to MPCP, does not require transmission on PLC channel
 - Could follow-up PLC announce, ack on A/C and then ack on PLC ?
 - May not require US for PLC at all

“Link” Setup

- Profiles consist of administratively permitted MCS combinations and can be both technical and policy based. Example use of profiles:
 - MCS A B C D E part of the spec
 - Operator chooses to support A C E
 - CNU Model 1 support A C
 - CNU Model 2 supports A E
 - Operator profiles possible:
 - A only
 - C only
 - E only
 - A / C
 - A / E
 - C / E
 - A / C / E
- Each MCS could support various rates or channel widths. Not sure if the variations with MCS would be handled as a subset of these (like A1, A2 or A:f1, Af2, etc.). Leave that to the spectrum team...

“Link” (PLC) Requirements/functions

- DS (DL)
 - CLT Must encode profiles into predetermined matrix
 - CLT assumes the MAC is up and running even when there are no CNU's connected. For this to work CLT must always be transmitting matrix
 - CLT Transmit must not be (AES) encrypted
 - CLT Transmit must be on permanently assigned symbol combinations
 - CLT PLC matrix is broadcast to all logical terminals (LTE hidden tags)
 - Would not need ACK (HARQ in 3GPP) if we continuously re-transmit
 - US (UL)
 - US random access channel information is included in information on PLC (equivalent of 3GPP master information block MIB)
 - US random access channel size is dependent on two #s:
 - Domain size (# of CNU's)
 - Frequency of changes expected
 - Resulting calculations will determine the probability of a failed access attempt (detectable only by the CLT) from a 'collision'. Larger channel, lower probability of collision.
 - Less frequent changes announced, less frequent changes of CNU's to different profiles
 - Do we need a PLC UL mechanism ? (I would say no we do not need this)
 - Does the CNU just listen to DS and then begin registration on a designated random access UL channel LEARNED from that information ?
- Number of symbols (effective logical use of physical channels depends on logical channel sizes and bw needed to transmit matrix). That in turn is largely dependent on the number of CNU's

Presentation from IEEE Meeting

NOV 2012 SAN ANTONIO

PHY Control Channel and PHY Initialization Procedures

Nicola Varanese (Qualcomm)

Summary

- A PHY Control Channel (PCCH) ~~is needed for~~
 - Aiding PHY initialization and CNU bring-up
 - Broadcasting information strictly necessary to enable the operation of the PHY layer (e.g., proper demodulation and decoding of data)
 - Collecting CNU-specific information (e.g., supported MCS in DS)
 - It does **not** convey MAC Control information (GATE/REPORT messages)
- In [boyd_01_0912], this has been termed “PHY Link”
 - “Frequency inserted”
 - Carried in every symbol
 - Enables a bi-directional protocol for PHY initialization (or “auto-negotiation”)
- This presentation introduces more details on the PCCH
 - Purpose (DS/US)
 - Information carried on the PCCH (DS/US)
 - PHY resources reserved for the PCCH (DS/US)
 - PHY initialization procedures related to the PCCH
- Assumption: MSC is adapted on a per-CNU (group) basis

Purpose of PCCH - Downstream

- PCCH Reference Signal: Aids PHY acquisition
 - Carrier frequency recovery
 - PHY frame synchronization

- PCCH Data: Broadcasts network information + CNU-specific information
 - OFDM channel ID
 - DS Bandwidth (Number of available sub-carriers in this OFDM channel)
 - Number of frequency notches
 - Start frequency of each notch
 - Bandwidth of each notch
 - Info regarding PHY frame structure
 - TDD split in terms of US/DS OFDM symbols and guard interval
 - FDD US information: carrier frequency, number of available subcarriers
 - Frequency Interleaving pattern (logical to physical subcarrier mapping)
 - Time Interleaving depth for DS
 - Active profiles (active MCS's)
 - **Timing advance information for specific CNU(s)**
 - **Assignment of specific CNU(s) to a given DS/US profile**
 - **Power control information for specific CNU(s)**

} Needs definition
of a PHY address

Resources Reserved for PCCH - Downstream

- A fixed number of subcarriers within all OFDM symbols (“frequency inserted”)

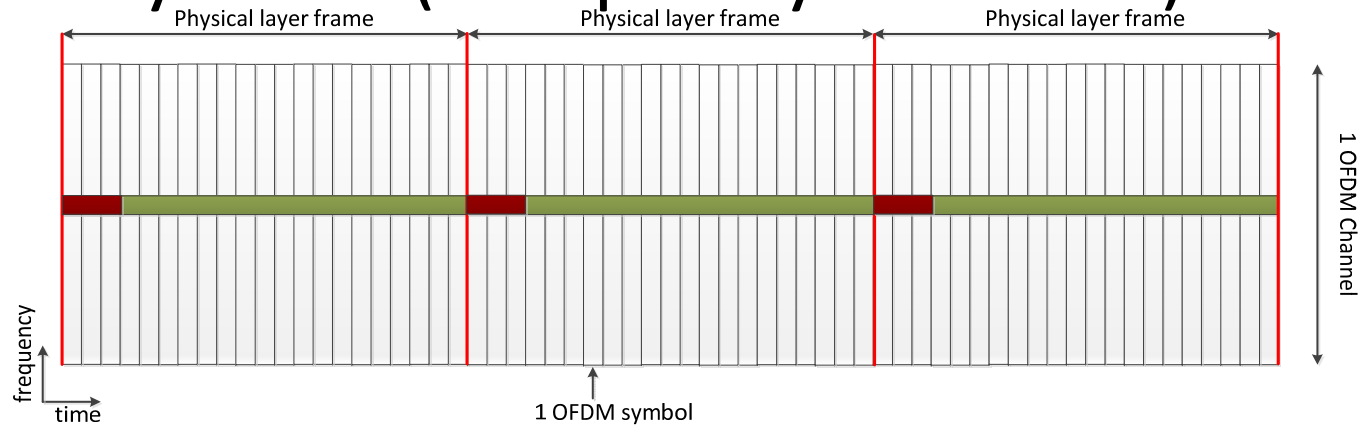

- It is also possible to have a f [01_0912].
- PCCH includes reference signals (RS) for PHY acquisition and PCCH data (format TBD)

PCCH RS

PCCH Data

Resources Reserved for PCCH - Downstream

- Example

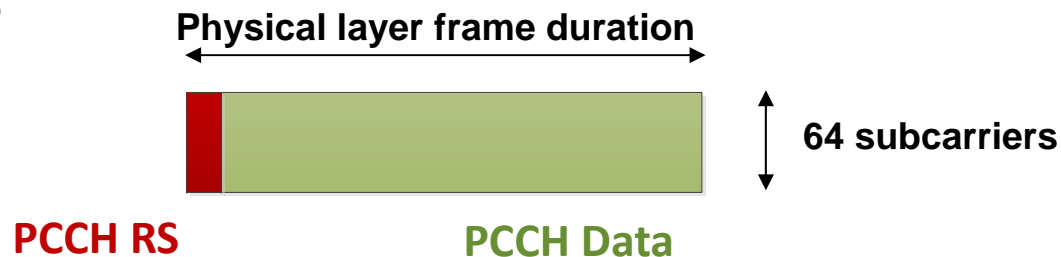

- Physical layer frame duration influences only the duration of the overall initialization phase
 - CNU has to first identify RS signal to obtain frame and frequency synchronization with respect to the CLT
- Data rate available for the PCCH and overall overhead (OH):
 - 64 subcarriers
 - 16-QAM modulation
 - 20us symbol duration (50kHz spacing)
 - 24 MHz available frequency resources (~512 sc)
- Excessive resource allocation for PCCH
 - Rate is much higher then strictly necessary
 - Overhead may be fairly large if not all frequency resources within one OFDM channel are used.

$$R_{\text{PCCH}} = 12.8 \text{ Mbps}$$

$$\text{OH}_{\text{PCCH}} \sim 12.5 \%$$

Resources Reserved for PCCH - Downstream

- A fixed number of OFDM symbols (“time inserted”)

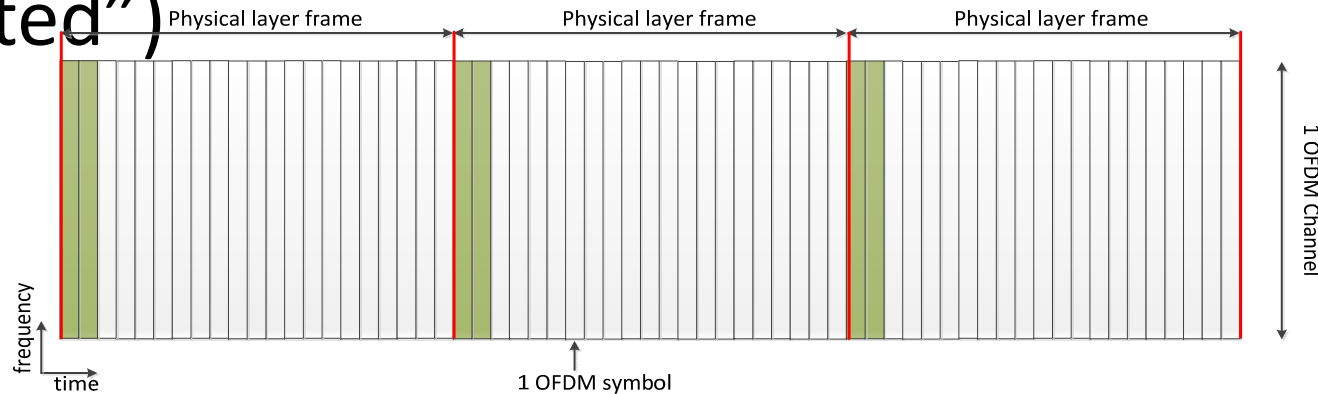

- Likely to reduce the overall overhead (similar to DVB-C2 approach)
- PCCH symbol includes reference signals (RS) for PHY acquisition and PCCH data

PCCH Data

PCCH RS



Option 1

PCCH Data

PCCH RS

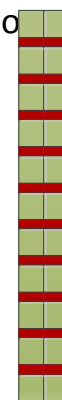

Option 2 (DVB-C2 -like)

Resources Reserved for PCCH - Downstream

- A fixed number of subcarriers within the first few symbols of a PHY frame

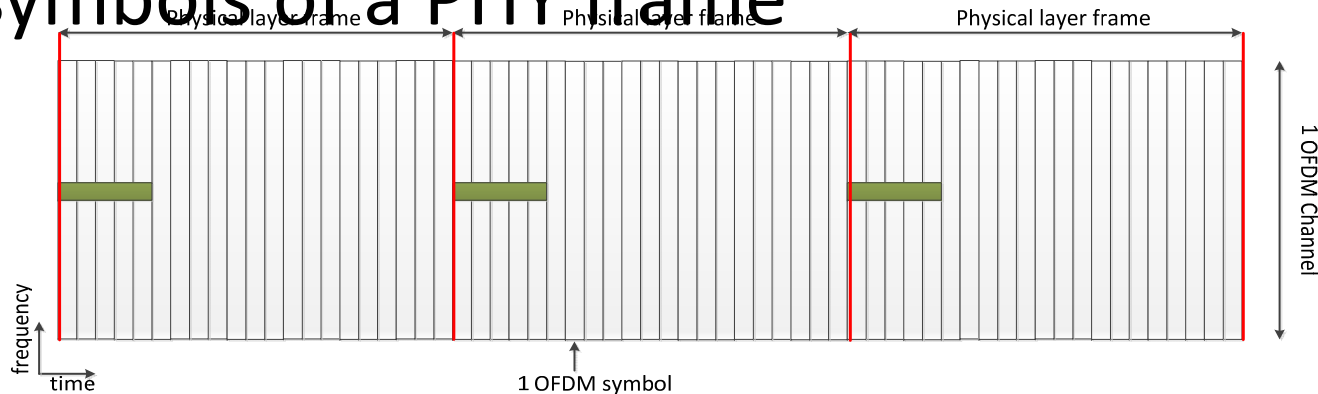

- Minimizes the overhead
- Rate adaptation is performed according to the net PHY rate (accounting for all overheads)
 - MAC is aware of the net PHY rate (accounting for all overheads).
- Moderate increase of buffering requirements at the PHY
 - No interleaving (worst case): proportional to the PCCH overhead and PHY frame duration in symbols (N_{FRAME})

$$\text{Buffer increase \%} = \text{OH}_{\text{PCCH}} \times N_{\text{FRAME}} \times 100$$

Purpose of PCCH - Upstream

- PCCH Reference Signal: Aids PHY procedures
 - Timing advance estimation for the CNU which is transmitting
 - Assignment of the CNU to a specific US profile (evaluation of US MCS)

- PCCH Data: CNU-specific information
 - PHY address identifying this CNU
 - Supported MCS for DS for this CNU (needed to assign CNU to a specific DS profile)
 - Unusable sub-carriers in DS for this CNU (needed by CLT to determine notches in DS)

Resources Reserved for PCCH - Upstream

- The upstream PCCH is accessed with a **contention-based protocol**
- Resources need to be reserved for the PCCH in upstream
 - Same options as for Downstream
 - A particularly convenient solution is to reserve a number of OFDM symbols

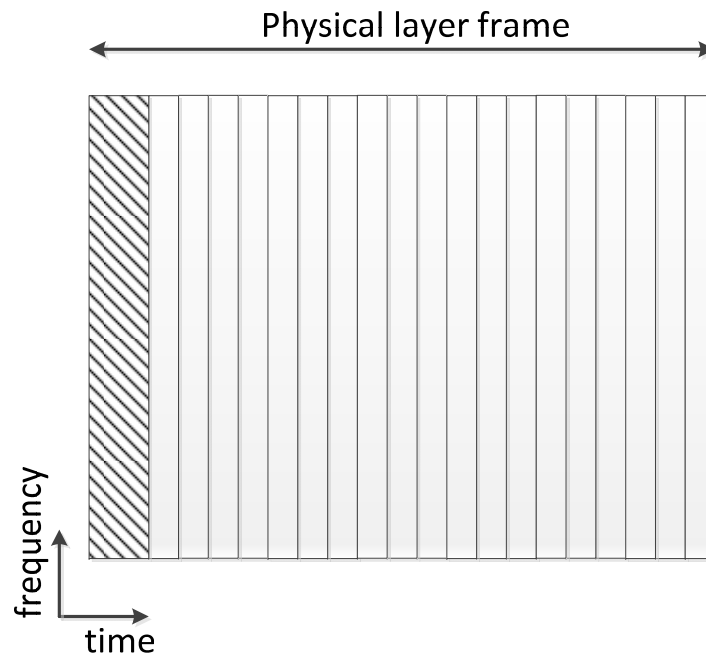

Resources Reserved for PCCH - Upstream

- The upstream PCCH is accessed with a **contention-based protocol**
- Resources need to be reserved for the PCCH in upstream
 - Same options as for Downstream
 - A particularly convenient solution is to reserve a number of OFDM symbols

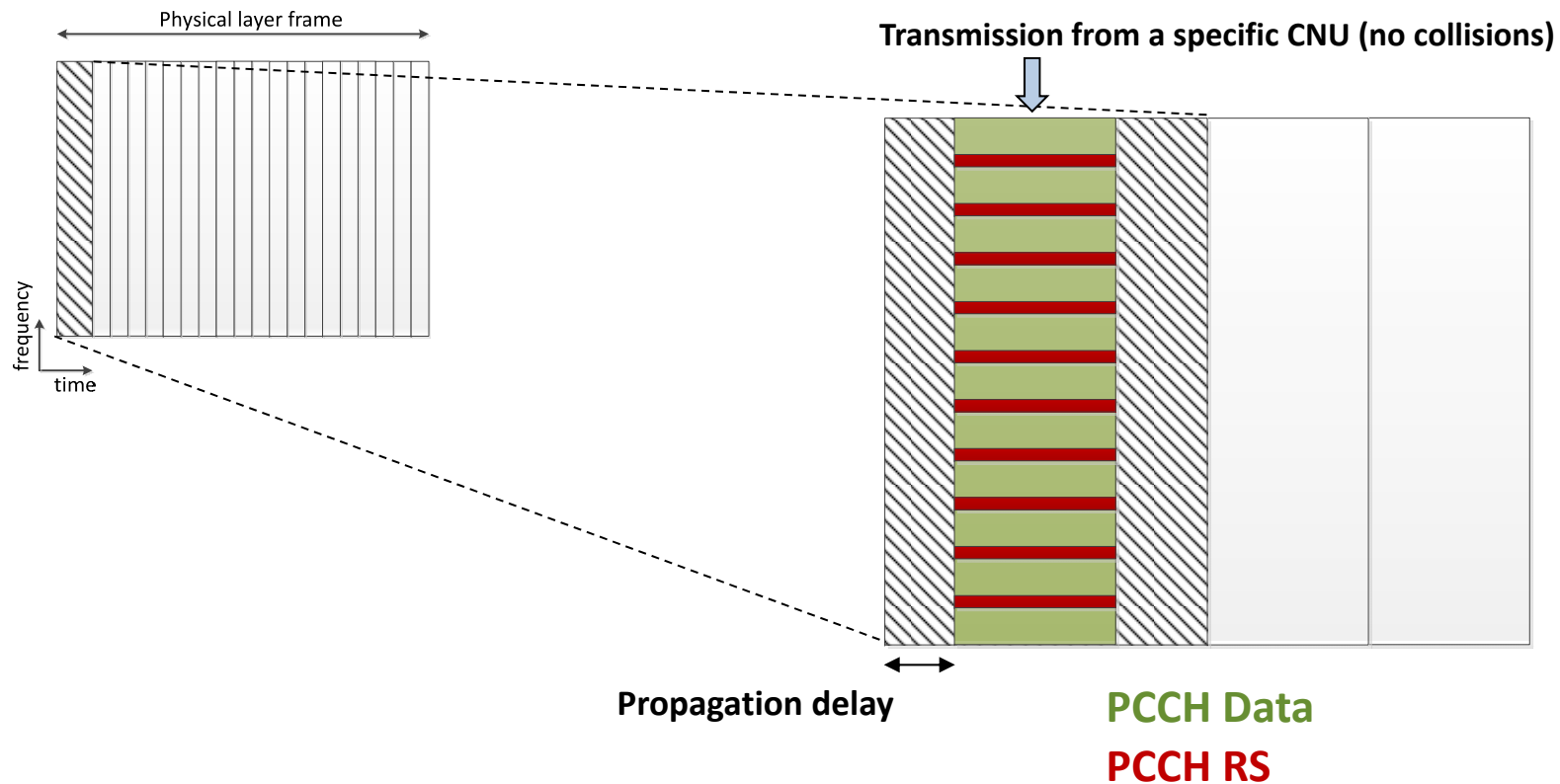

Resources Reserved for PCCH - Upstream

- The upstream PCCH is accessed with a **contention-based protocol**
- Resources need to be reserved for the PCCH in upstream
 - Same options as for Downstream
 - A particularly convenient solution is to reserve a number of OFDM symbols

Features:

- CLT estimates full channel for the user and assigns US profile
- CLT estimates timing advance (to compensate propagation delay)
- CLT estimates optimal power control settings
- CNU is identified after decoding PCCH Data

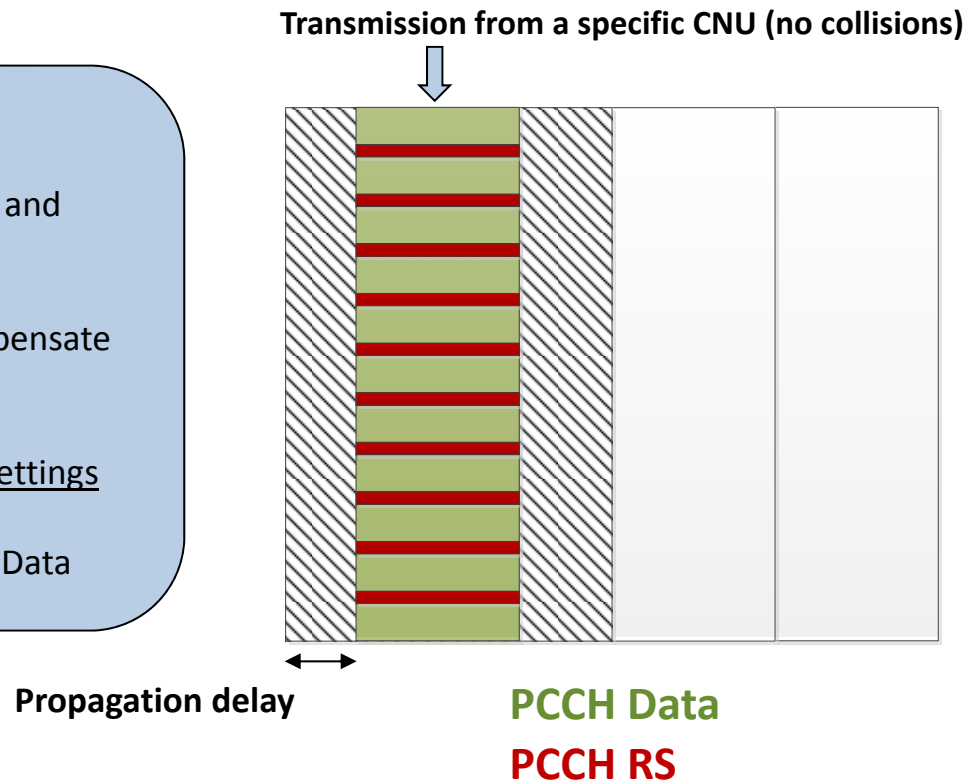

Timeline of PHY Initialization Procedure

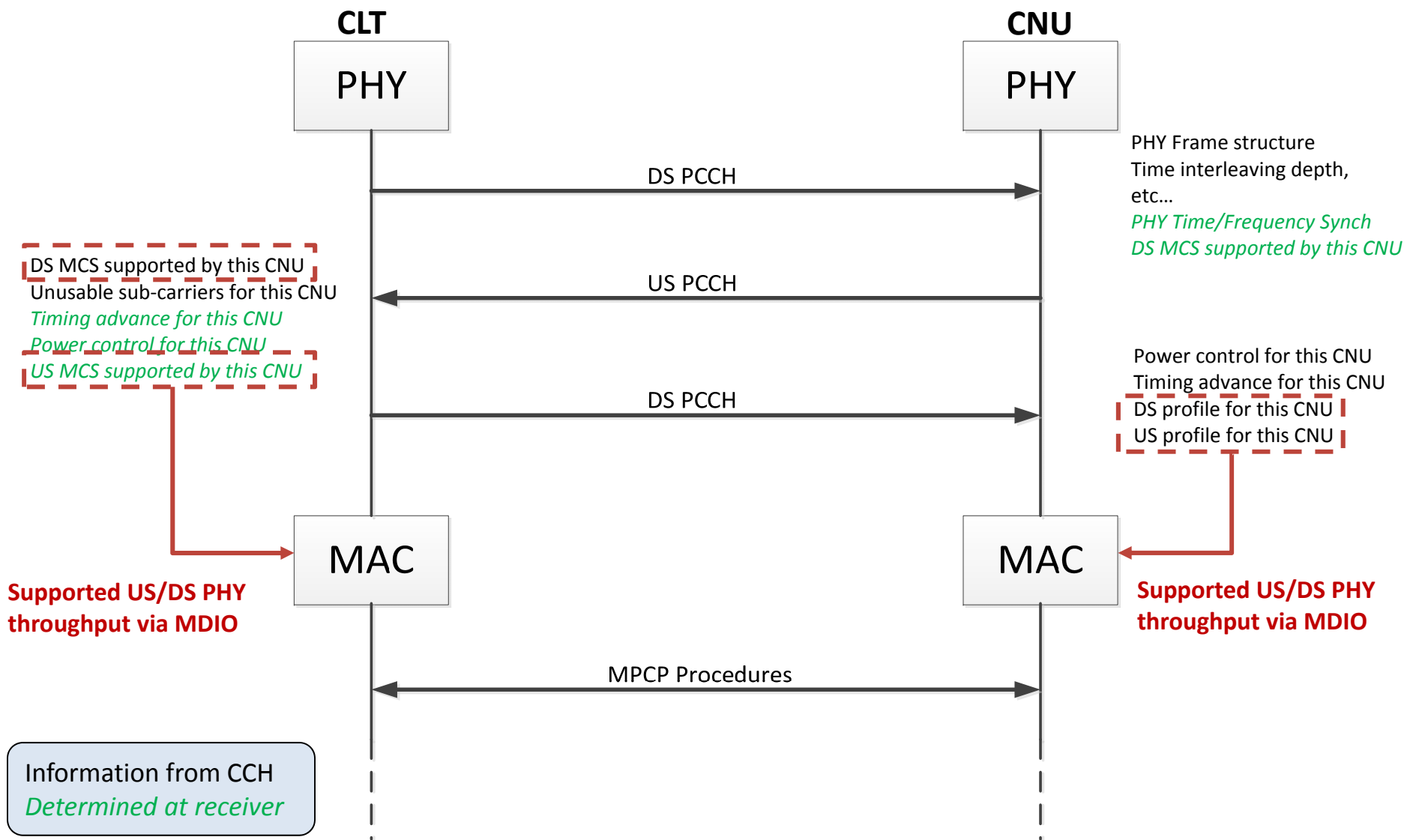

Notes on PHY Initialization Procedures

- US and DS PCCH use the lowest MCS
 - e.g., 16 or 64-QAM with strong FEC and time interleaving
 - Further details on PCCH data structure TBD
- DS PCCH has its own time/frequency interleaving
- There is no need for a complex protocol for exchanging information over the PCCH
 - Simple three-way exchange
- DS PCCH is a broadcast channel
 - i.e., information on the PCCH can be decoded by all CNU's
 - It contains both broadcast (network info) and unicast (CNU-specific) information

Proposals

- PCCH is carried only in selected few OFDM symbols within a PHY frame
- Simple PHY initialization procedure (Slide 11)

Presentation from IEEE Meeting

NOV 2012 SAN ANTONIO

PHY Link Up

Avi Kliger, Broadcom

Overview

- This presentation provides a baseline proposal for the PHY Link up procedure for EPoC
- It is a continuation of presentations from the 2012 Geneva meeting
 - *EPoC PHY Link and Auto-Negotiation / Ed Boyd et al. Geneva. Sept 2012*
 - *Baseline Proposal for EPoC PHY Layer / Avi Kliger et al. Geneva Sep 2012*
- The PHY Link Up procedure is transparent to the EPON MAC

PHY Link Channel (PLC)

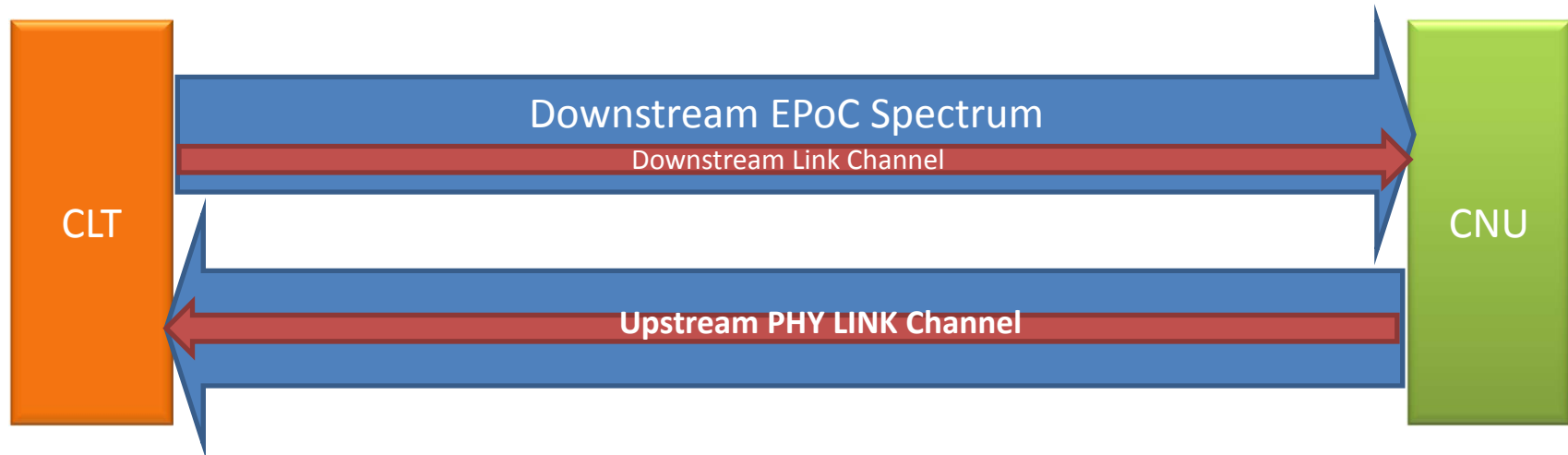

- In-band PHY control channel not visible to MAC
 - Downstream and Upstream
- Purpose
 - PHY link up procedure transparent to MAC
 - PHY link control and management of linked CNUs transparent to MAC
- Link up procedure on PHY level until PHY link is established
- Once link is established MAC starts running messages and data

Downstream PHY Link Channel

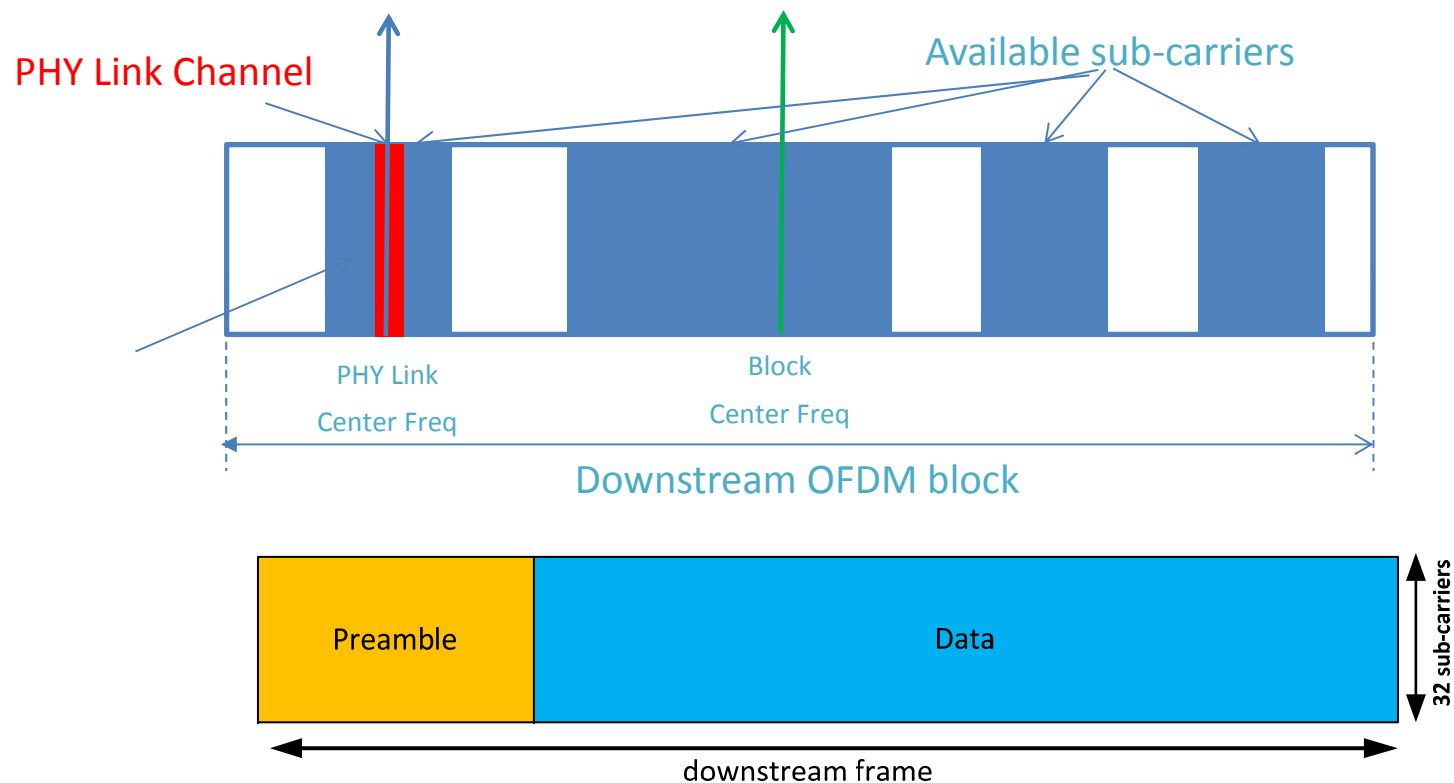

- Use 32 subcarriers for the Link Channel
 - < 1% of the 192 MHz OFDM channel
- Aligned to a 6/8 MHz legacy channels
- Uses fixed constellation with own FEC
- A periodic Preamble followed by a block of data
- Preamble can be used as a marker of a Downstream Frame
- Preamble period could be 2.5-5 mSec

Protection of the PLC in the Downstream

- Narrow band signal is more susceptible to ingress noise or notch in the frequency domain
- Use a single frequency for the PLC
 - Lower modulation order than the lowest allowed for data to improve robustness
 - With this additional protection It is unlikely that a failure will occur in the downstream
 - CLT PHY has the capability to change the
- Alternatively: PLC hops between two frequencies
 - Add frequency diversity
 - May double time of PLC search

Upstream PHY Link Channel

- Use a fixed number of sub-carriers on each upstream OFDMA frame (e.g. 32 sub-carriers)
- A CNU PHY transmits upstream in response to a downstream PHY Link message from the CLT PHY
 - One transmitter per OFDMA frame
 - CLT can specify different sub-carriers for PHY Link response
 - CLT can specify different bit loading for PHY Link response
 - Minimal constellation is QPSK
- Used for upstream signaling and messaging
 - Coarse and fine adjusting upstream symbol alignment
 - Periodic EVM probes
 - Status information from the CNU e.g. EVM per sub-carriers, errors, ...
 - Power management related settings

Upstream PHY Discovery Signal ("Broadcast Link Response")

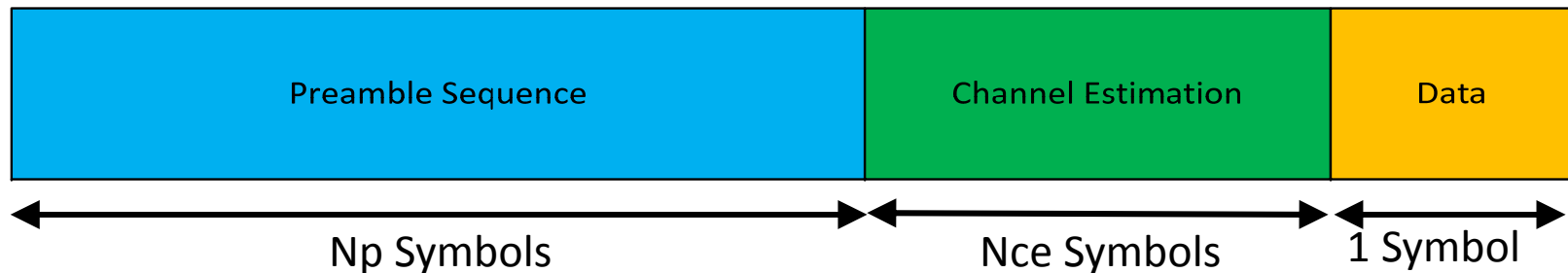

- Used by the CNU to identify itself for initial link process including symbol time alignment and transmit power adjustment
- All upstream transmissions must arrive at the CLT PHY aligned to the same OFDMA time reference and received power
- Uses 32 sub-carriers (1.6 MHz)
- Embedded in the OFDMA Frame
- Sub-carriers are dynamically set by the CLT PHY
- A Preamble is followed by data
 - PHY ID
- Length of Preamble depends on the max propagation delay supported
- May exceed one OFDMA frame

Initial Link Procedure

- Link process has four states

- Downstream PLC receive
- Initial upstream alignment
- Bit loading in the upstream
- Bit loading in the downstream

- With multi-profiling Profile

- Ranging uses the Broadcast (Baseline) Profile
- Additional profile settings can be done once the CNU is in the network

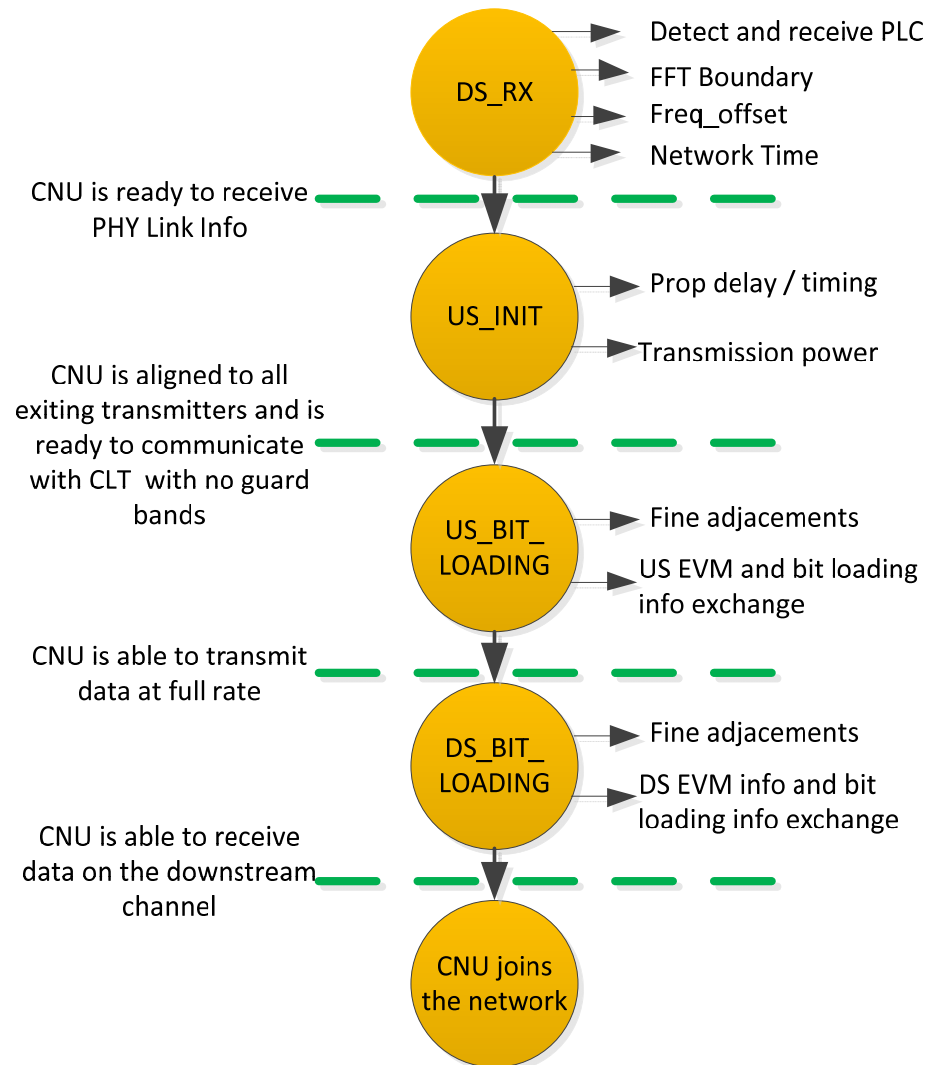

Initial Link Up State

Receive Downstream PLC

- CNU search for the PHY Link Channel
 - Scan over all possible PLC center frequencies (~ 150 frequencies in a 900 MHz range)
 - A Preamble is sent every downstream frame , assume every ~ 2.5 or 5 mSec
 - one scan over all frequencies 400 to 800 mSec
 - Once a Preamble is detected the CNU can find CP size, FFT boundaries, frequency offset ...
- Acquire timing and carrier frequencies
- CNU adjusts its transmit OFDM sampling frequency and carrier frequency to the downstream

Link Up State

Initial Upstream Alignment (Part 1)

- CNU waits for PHY Discovery Opportunity
- CNU transmits Broadcast Link Response
- Wait for acknowledge on the PLC with corresponding PHY ID
- If acknowledge arrives before Time Out the CLT and the CNU can start exchanging alignment commands and responses
- If acknowledge didn't arrive before Time Out, the CNU will continue sending Broadcast Link Respond signals with back off and power adjustments
- Transmission power is set according to the Initial Transmission Power Control protocol

Link Up State

Initial Upstream Alignment (Part 2)

- Once the CLT PHY is able to receive the Broadcast Link Response it initiates fine tuning protocol using the Node ID
- The CLT PHY sends commands with the corresponding PHY ID over the PLC
 - Fine time alignments times and transmission power setting
- CNU set transmission times and transmission power and responds with an acknowledge message
- CLT continues until it is satisfied with the received performance
- At the end of this state the CNU can send data in the OFDMA frame without using the Broadcast Link Response

Link Up State

Upstream Bit Loading

- For upstream SNR estimations
 - CLT PHY schedules transmission opportunities for the CNU to send Probe Signals over the Upstream PHY Channel
 - Scans all available sub-carriers
 - Once settled CLT PHY exchanges bit loading information with the new CNU over the downstream PLC
- Once CLT PHY is satisfied with the performance of the new CNU it terminates the Upstream SNR Probing state
- At the end of this state the CNU can send data at high throughput

Link Up State

Downstream Bit Loading

- CNU receive PHY information
 - PLC carries all information required to properly receive the downstream transmission over all OFDM channels
- CNU Measures SNR over all sub-carriers
 - Can use pilots and / or data to assess the SNR per sub-carriers
 - Should we specify Probes in the downstream?
 - CNU verifies ability to reliably receive the downstream broadcast profile
- CNU sends SNR information on all sub-carriers
- At the end of this state the CNU is able to receive downstream data in the Broadcast Profile

Adaptation to Multi-Profiling

- This propose Link Up process can work with multi profiling
- Use the Broadcast (baseline) Profile for the Link Up
- PLC carries the Broadcast Profile information
- Other profiling assignments and bit loading updates could be determined when the new CNU is on the network

Probing Signals Considerations

- Downstream
 - SNR per sub-carrier can be measured by averaging slicer SNR over time on data or pilots
 - Do we need special Probe Signals from the Downstream?
 - Rotated Pilots?
 - How would they be transmitted? Rotating PLC?
 - MAC messaging? OAM?
- Upstream
 - CLT scheduled rotating probes over some of the sub-carriers
 - Periodically and when required
 - Bit loading information can be delivered on the PLC?
Management messages?

Ranging Requirements Considerations

- Essential to define the Broadcast Link Response and initial alignment
- Maximal round trip time (RTT)
 - For Node+5 1.5 km distance may be enough -> 12 uSec
 - Is this good enough?
- Number of CNU's
- How many may admit simultaneous
 - Would one in a time be sufficient?
- Total time required for a single CNU to join the network
 - First time, after drop or power failure