

# EPoC Burst Marker Proposal for EPoC 802.3bn

Leo Montreuil, Broadcom

Avi Kliger, Broadcom

Rich Prodan, Broadcom

March 16-21, 2014 Beijing, China

# Supporters

- Hesham ElBakoury, Huawei

# 2-D Burst Marker Design (1)

## 2-D “B” and “N” sequence

- Burst Marker size is  $N_f \times N_s$ . Size determine performance for false and misdetection
- 1:1 ratio of BPSK “B” to Nulls “N” is best performance
- $N_f$  (frequency direction size) should be even, allowing boosting the power of “B” subcarriers by 2 without increasing total output power
- $N_s$  (time direction size) can be a odd or even

# 2-D Burst Marker Design (2)

## 2-D “B” and “N” sequence

- Best 2-D auto-correlation sequence is selected (by exhaustive search)
- BM can be interspersed with the data and pilots to improve robustness
- Stop marker is the complement of the Start sequence:
  - “B”  $\rightarrow$  “N” and “N”  $\rightarrow$  “B”

# 2-D Burst Marker Design (3)

## 1-D “B” sequence

- “B” sequence is 1-D BPSK of length  $(N_f \times N_s)/2$ 
  - No position ambiguity, set by the 2-D sequence.
- Sequence boosted by 2 (3 dB) for robustness.
- Best 1-D auto-correlation sequence selected (by exhaustive search). Some circular shifts of a sequence are mutually orthogonal.
- Profile encoded on BPSK sequence. Each profile has its own circular shift of the base sequence. Examples:
  - BM 4x4 BPSK profile 0 (no shift) :  $S_0 = [-1 \ 1 \ 1 \ 1 \ 1 \ -1 \ 1 \ -1]$ ;
  - BM 4x4 BPSK profile 1 (shift +1) :  $S_1 = [-1 \ -1 \ 1 \ 1 \ 1 \ 1 \ -1 \ 1]$ ;
  - BM 4x4 BPSK profile 4 (shift -3) :  $S_4 = [1 \ 1 \ -1 \ 1 \ -1 \ -1 \ 1 \ 1]$ ;

# Proposed 2-D Burst Marker, Profile 0

4x4 Start BM

	0	-1	0	1
Frequency ↓	1	0	1	0
	0	1	-1	0
	1	0	0	-1
	Symbol →			

4x6 Start BM

0	-1	0	1	1	0
1	0	1	0	0	1
0	-1	-1	0	0	1
1	0	0	-1	1	0

4x8 Start BM

0	-1	0	1	1	1	0	0
1	0	1	0	0	0	-1	1
-1	0	1	0	1	0	0	-1
0	-1	0	-1	0	1	-1	0

- 4x4 BM “B” sequence:  **$S_0 = [-1\ 1\ 1\ 1\ 1\ -1\ 1\ -1]$** 
  - 7 mutually orthogonal sequences by circular shift of [0,1,2,3,-3,-2,-1]
- 4x6 BM “B” sequence :  **$S_0 = [-1\ 1\ 1\ 1\ 1\ 1\ -1\ -1\ 1\ 1\ -1\ 1]$** 
  - 11 mutually orthogonal sequences by circular shift of [0,1,2,3,4,5,-5,-4,-3,-2,-1]
- 4x8 or 8x4 BM “B” sequence :  **$S_0 = [-1\ 1\ 1\ 1\ 1\ 1\ -1\ 1\ -1\ 1\ -1\ -1\ -1\ 1\ -1]$** 
  - 13 mutually orthogonal sequences by circular shift of [0,1,...,6,-6,-5,...,-1]
- Stop marker is complementary to Start marker, “B” → “N” , “N” → “B”
- Profile sequence is on Start and Stop marker. First element is top left corner, then left to right and top to bottom.
- Start BM is preceded by one subcarrier carrying Pilots and Data. Stop BM is followed by one subcarrier carrying Pilots and Data (see examples).

# Examples of BM 4x4 in 8 symbols RB

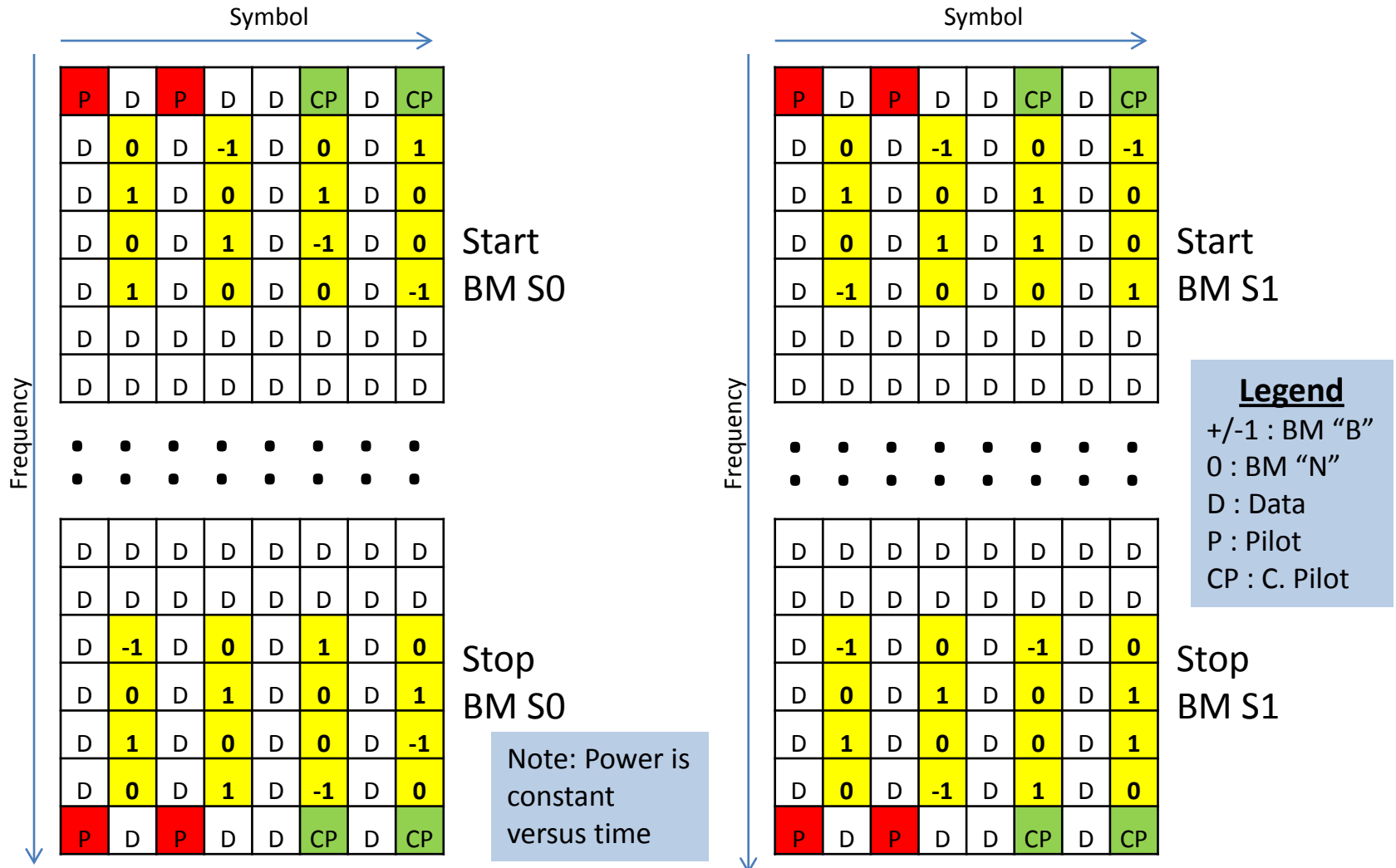

# Examples of BM 4x6 in 8 symbols RB

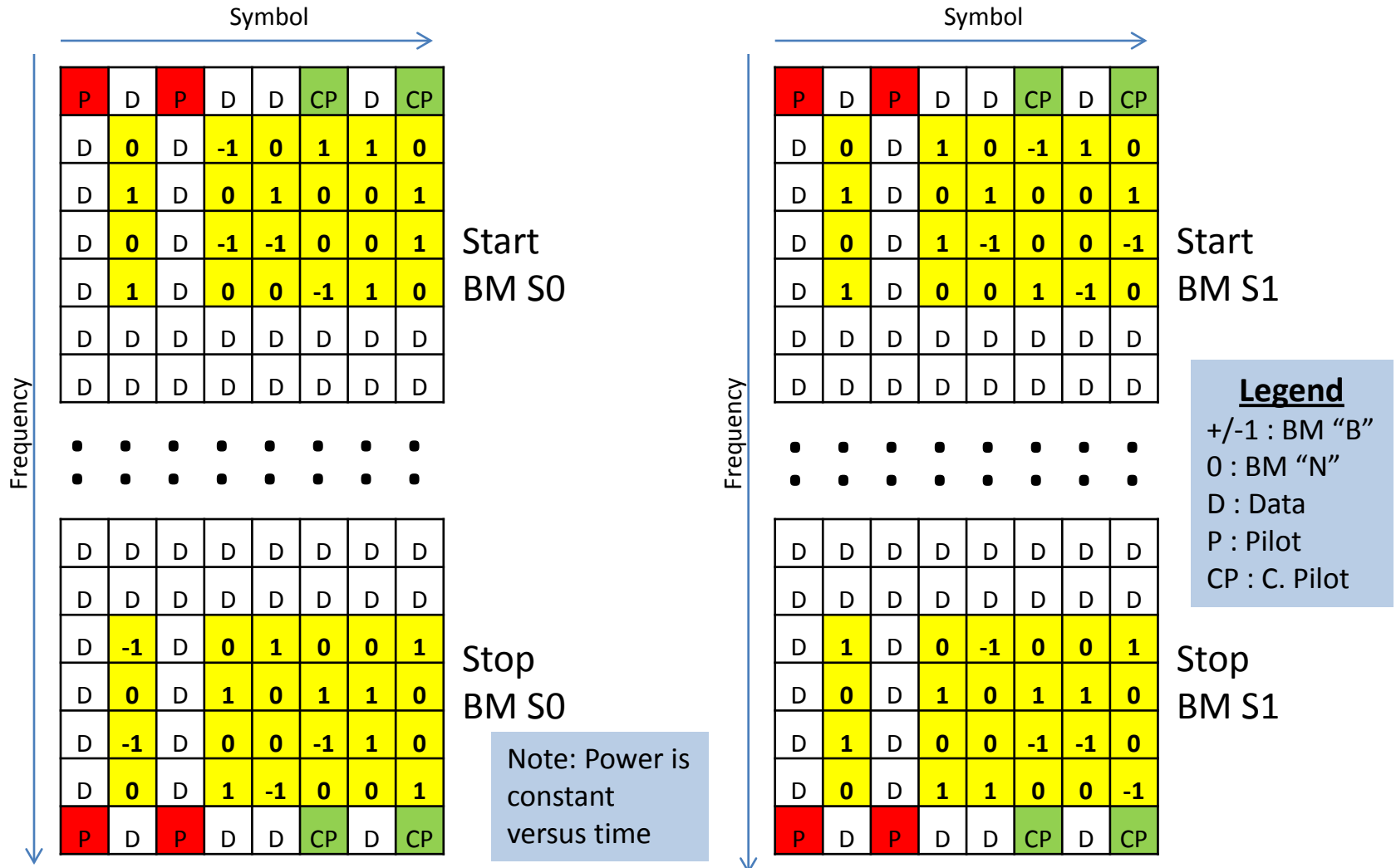



# Examples of BM 4x6 in 12 symbols RB

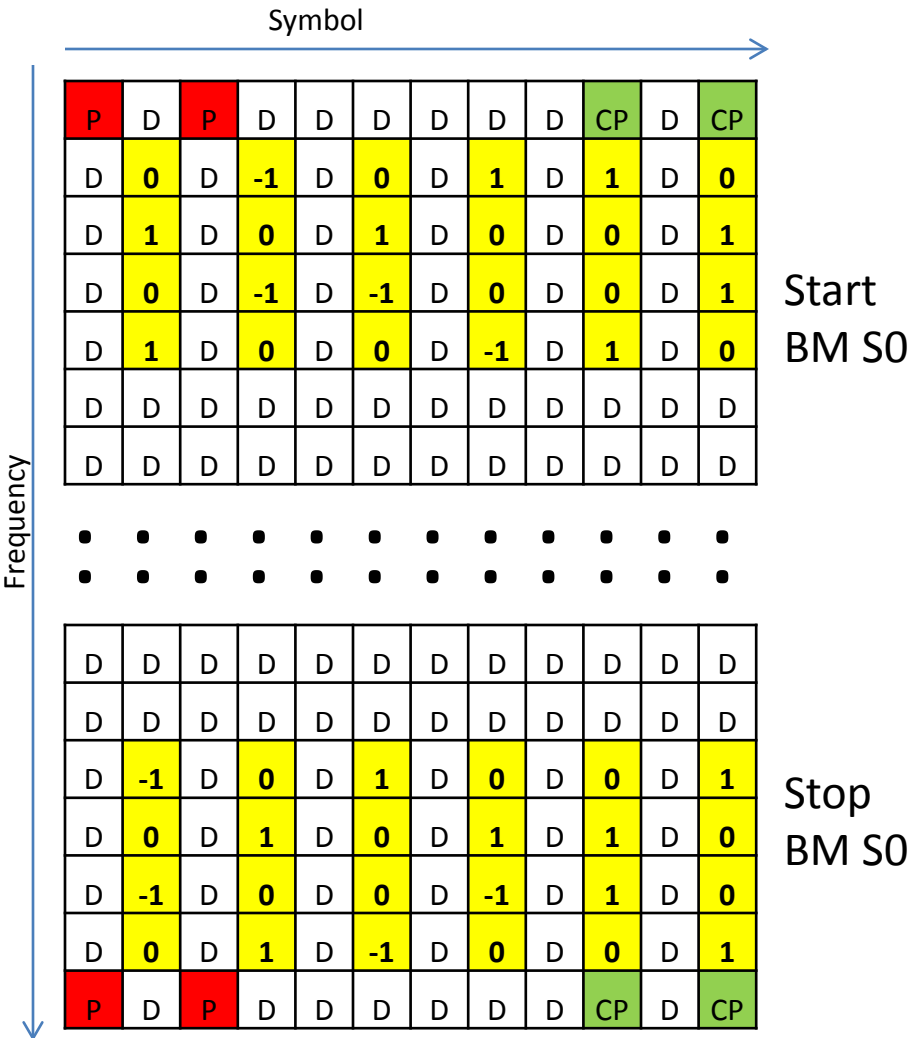

**Legend**

- +/-1 : BM "B"
- 0 : BM "N"
- D : Data
- P : Pilot
- CP : C. Pilot

Note: Power is constant versus time

# Examples of BM 4x6 in 16 symbols RB

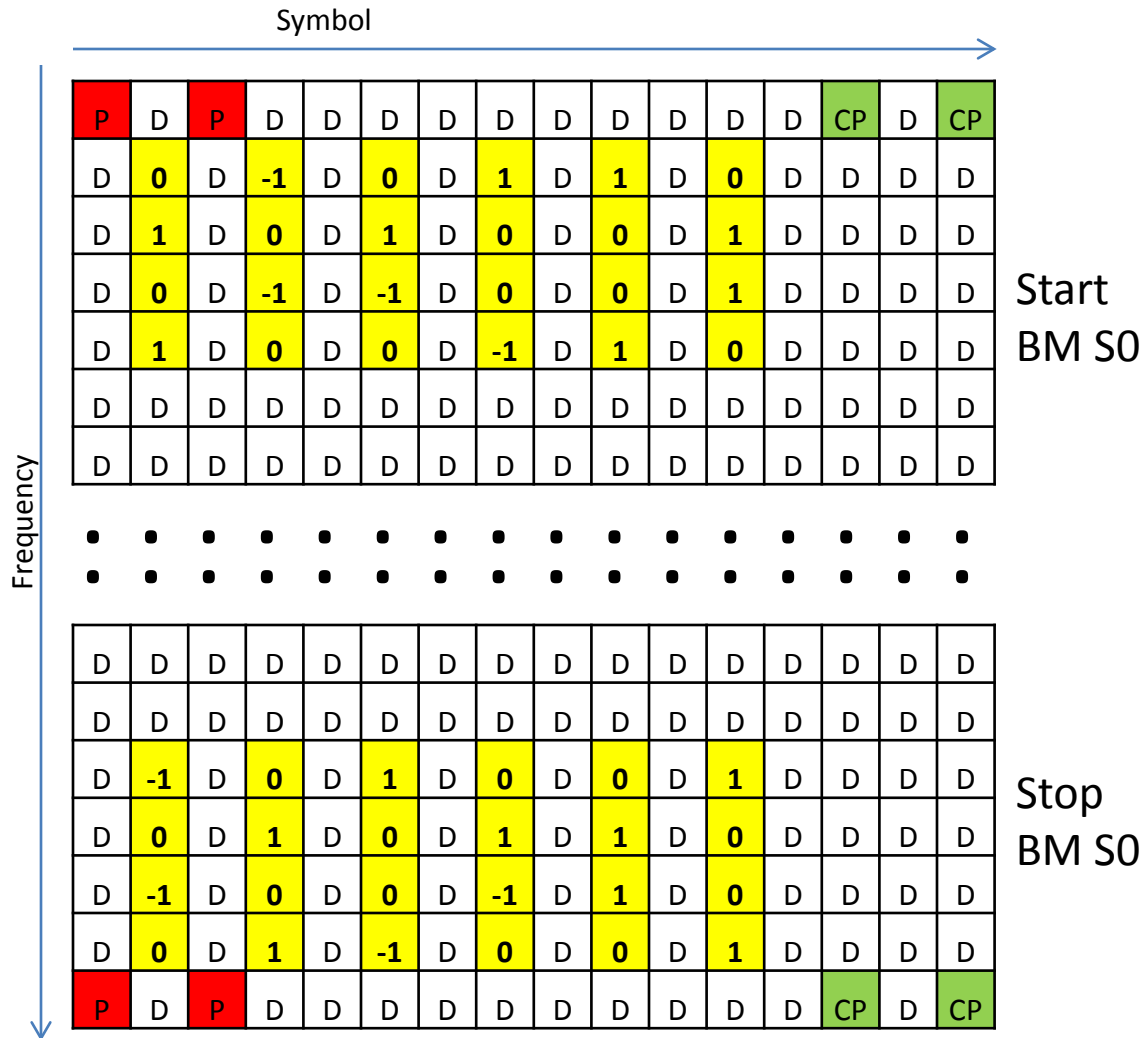

**Legend**  
 +/-1 : BM "B"  
 0 : BM "N"  
 D : Data  
 P : Pilot  
 CP : C. Pilot

Note: Power is constant versus time

# Examples of BM 4x8 in 8 symbols RB



# Burst Marker False and Misdetection with Data

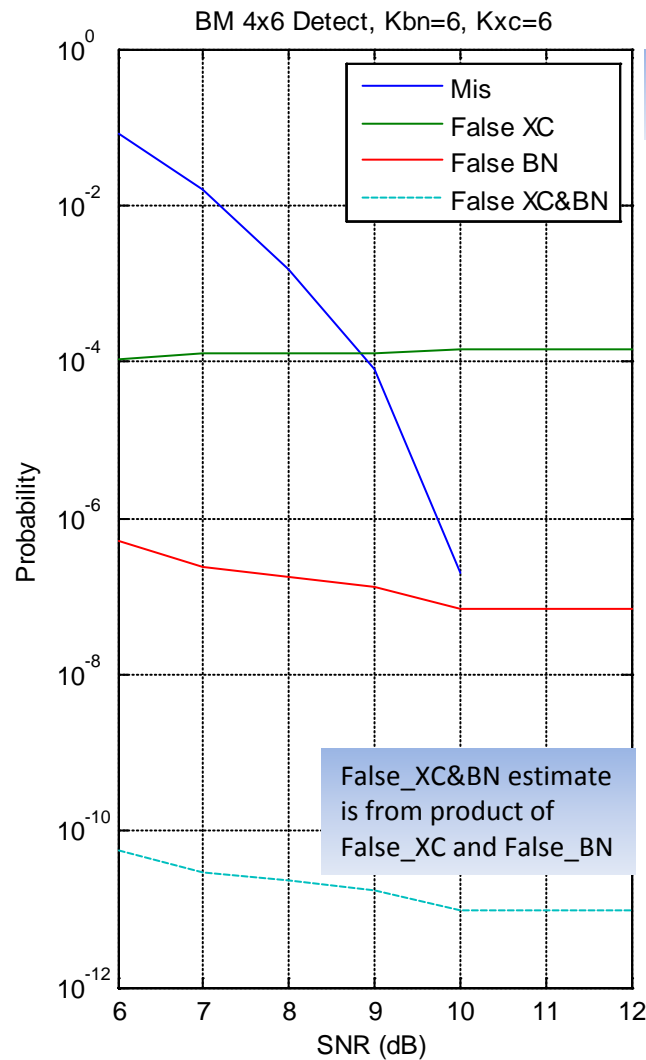
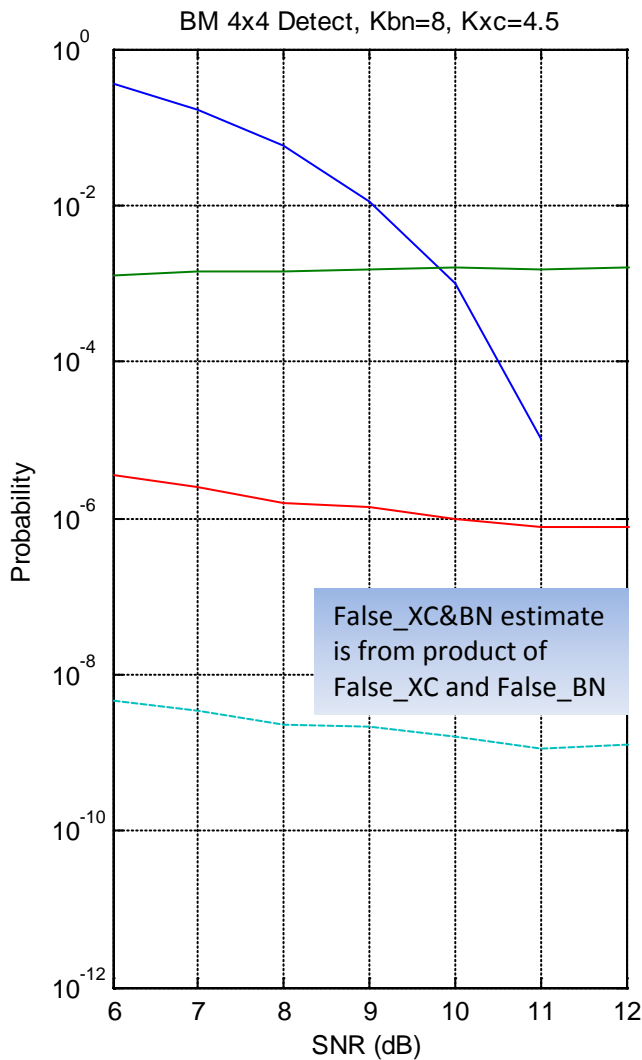

BM simulated in presence of 64-QAM

# Burst Marker False and Misdetection with Data

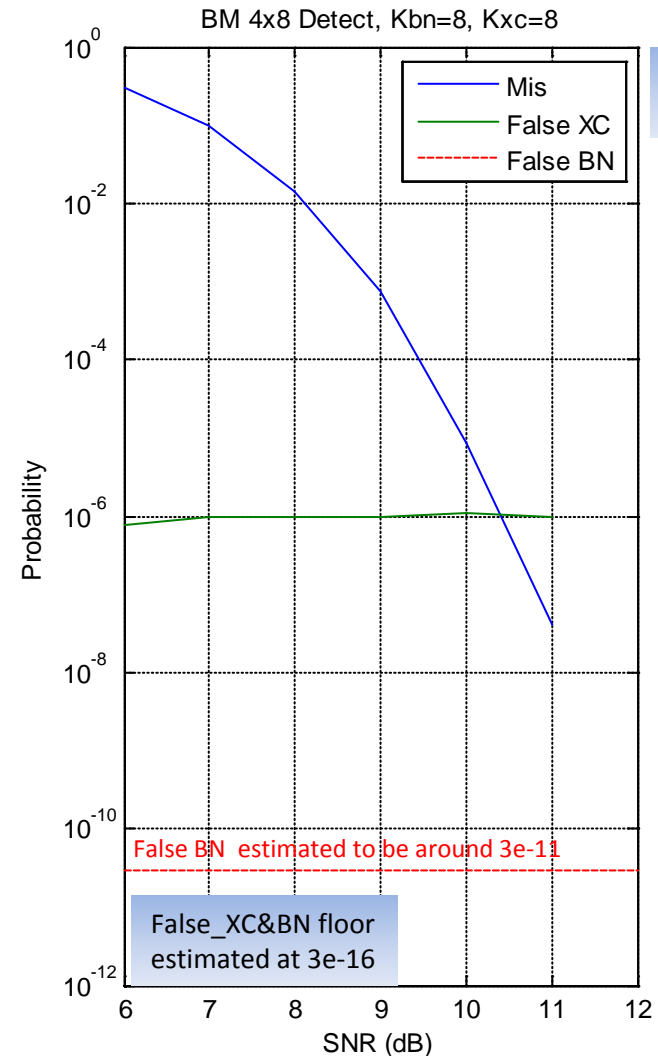
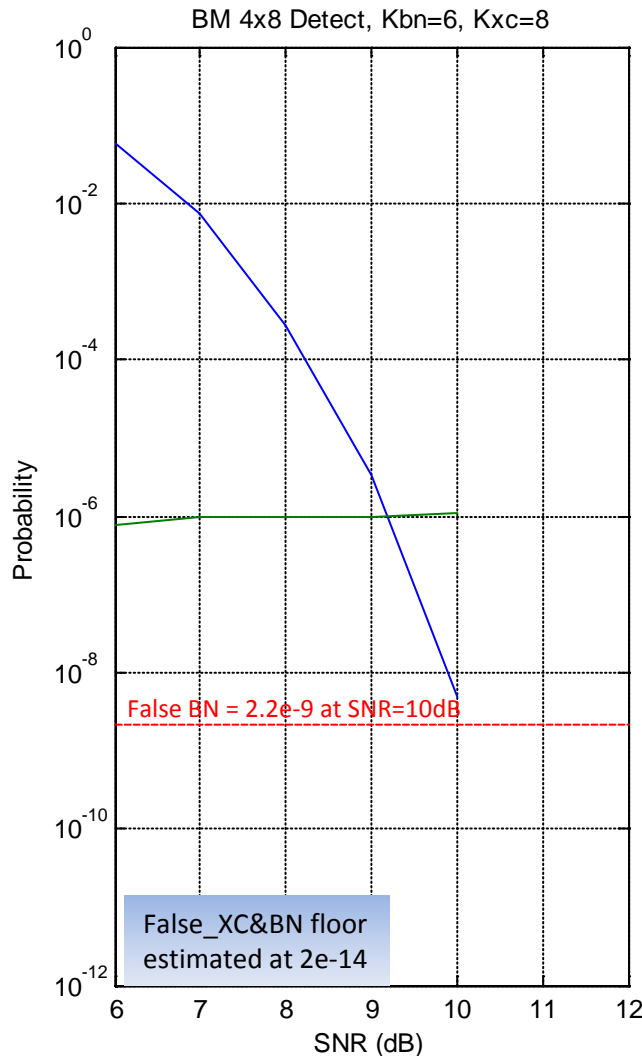

BM simulated in presence of 64-QAM

# BM Detector Simulation with Additive White Gaussian Noise only (no BM or Data)

- BM 4x4,  $K_{bn} = 8$ ,  $K_{xc} = 4.5$ 
  - False\_BN =  $7.5e-5$ , False\_XC =  $9.3e-4$ , False\_XC&BN =  $6.5e-8$
- BM 4x6,  $K_{bn} = 6$ ,  $K_{xc} = 6$ 
  - False\_BN =  $2.2e-5$ , False\_XC =  $7.9e-5$ , False\_XC&BN =  $1.7e-9$
- BM 4x8,  $K_{bn} = 6$ ,  $K_{xc} = 8$ 
  - False\_BN =  $1.1e-6$ , False\_XC =  $2.5e-6$ , False\_XC&BN =  $2.8e-12$
- BM 4x8,  $K_{bn} = 8$ ,  $K_{xc} = 8$ 
  - False\_BN =  $4.2e-8$ , False\_XC =  $2.5e-6$ , False\_XC&BN =  $1.1e-13$

# BM Detector Threshold in Presence of CW Interference (1)

- CW interference (in noise free channel) prevents detection of BM. At threshold, Misdetection error rate 50%!
- Definitions:
  - $N_i$  is number of “N” RE corrupted by CW
  - $P_{cw}$  is power of CW (note: Data power is 1 and “B” is 2)
  - $K_{bn}$  is scaling of sum of “N” RE power
- BM 4x4 threshold for:  $N_i * P_{cw} * K_{bn} > N_B * 2$   
for  $N_B = 8$  and  $K_{bn} = 8$ , then  $P_{cw} > 2/N_i$ 
  - CW on one subcarrier :  $N_i = 2 \rightarrow P_{cw}$  at 0 dB
  - CW on one symbol :  $N_i = 2 \rightarrow P_{cw}$  at 0 dB

# BM Detector Threshold in Presence of CW Interference (2)

- BM 4x6 threshold for:  $N_i * P_{cw} * K_{bn} > N_B * 2$   
for  $N_B = 12$  and  $K_{bn} = 6$ , then  $P_{cw} > 4/N_i$ 
  - CW on one subc. :  $N_i = 3 \rightarrow P_{cw}$  at +1.25 dB
  - CW on one symbol :  $N_i = 2 \rightarrow P_{cw}$  at +3 dB
- BM 4x8 threshold for:  $N_i * P_{cw} * K_{bn} > N_B * 2$   
for  $N_B = 16$  and  $K_{bn} = 6$ , then  $P_{cw} > (32/6)/N_i$ 
  - CW on one subcarrier:  $N_i = 4 \rightarrow P_{cw}$  at +1.25 dB
  - CW on one symbol :  $N_i = 2 \rightarrow P_{cw}$  at +4.26 dB



# Simulink Model of BM 4x6 Detector and Correlator

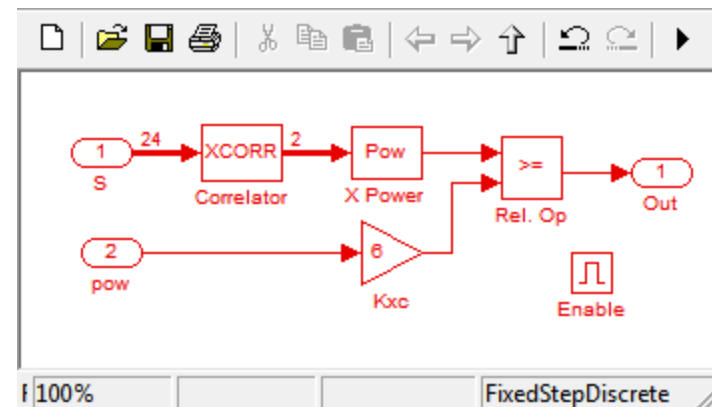
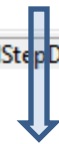
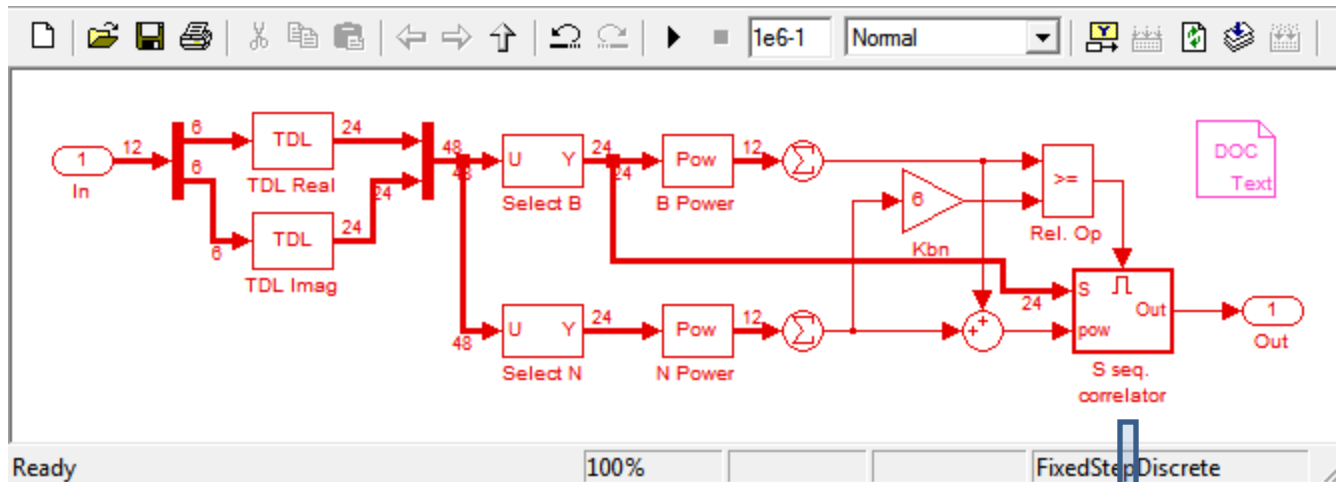

$$K_{bn} = 6$$

$$K_{xc} = 6$$

Note: To find error floor, simulation up to 1e10 search.

# Remark

- With 16-QAM or higher data constellations, false detection error floor is:
  - BM 4x4: False detection floor  $\approx 1e-9$
  - BM 4x6: False detection floor  $\approx 1e-11$
  - BM 4x8: False detection floor  $\approx 3e-16$
- “B” & “N” sequence detection not affected for BM on non-contiguous spectrum or spanning across 2 frames for partially pre-equalized US.
- “B” BPSK sequence correlation may require pre-equalized upstream.
- BM 4x4 requires aggressive threshold for low error floor
  - not a lot of margin!

# Recommendation

- Use a single Burst Marker: BM 4x6 (slide 6)
  - Simplicity
  - Robust enough for low packet error rate
  - Minimal overhead
  - Up to 11 profiles for signaling
  - Low implementation complexity
  - Distinct Start and Stop Markers
  - Unity power

# PROPOSED MOTION #

- Adopt the 4x6 Burst Marker as described in Slide 6 as baseline for 802.3 EPoC (mapping in RB examples on slide 8-10)
  - Stop marker is the complement of “B” & “N” Start Marker pattern
  - Non-nulls “B” boosted by a factor of 2 in power (3.01 dB)
  - Profile 0 encoded on “B” using S0 sequence
  - Orthogonal circular shifts of S0 sequence used for other profiles
- Moved by:
- Seconded by: