



Adaptive Modulation and Coding

Andrea Garavaglia and Juan Montojo
(Qualcomm)

Supported by

- Nicola Varanese (Qualcomm)
- Charaf Hanna (ST Micro)
- Duane Remein (Huawei)
- Hesham ElBakoury (Huawei)
- Guangshen Wu (Huawei)
- Lup Ng (Cortina)
- Venkat Arunarthi (Cortina)

Why adaptive modulation and coding scheme?

- Two very important benefits are achievable by adapting the downstream transmission to the user channel conditions:
 - A. Increase of overall performance of the cable plant
 - B. Reduction of SNR margins and easier operations – the plant is automatically adjusted to the user condition
- These two benefits directly translates into CAPEX and OPEX savings/benefits for operators:
 - more data can be delivered in the plant due to optimized matching of channel conditions for groups of users and reduced SNR margins
 - automatic adjustments to slowly varying channel conditions achieved by assessing and grouping users, without human intervention

Scope

- In past contribution [1] the authors illustrates analysis of SNR values on measured and modeled cable plants for EPoC, where it was shown that introducing adaptability is beneficial
- This presentation refines that analysis with further elaboration of SNR data (see appendix) and proposes to introduce multiple MCS for EPoC downstream
- The presentation includes a proposal describing how this can be while minimizing changes and limiting system complexity as compared to solutions
 - Further details about specification impact for different candidate features for EPoC are captured in [2]

SNR Analysis - Executive Summary

SNR Estimates	Broadcast per plant		Broadcast per user group	
	Common MCS (reference)	Bit loading	Single MCS per user group	Bit loading per user group
Average spectral efficiency	7.2 bps/Hz	9.4 bps/Hz	9.5 bps/Hz	10.3 bps/Hz
Gain	--	30%	32%	43%
Peak User Spectral efficiency	7.2 bps/Hz	9.4 bps/Hz	10.8 bps/Hz	10.8 bps/Hz
Gain	--	30%	50%	50%

SNR Measurements	Broadcast per plant – Common MCS	Broadcast per user group – single MCS per user group
Average spectral efficiency	9.0 bps/Hz	10.5 bps/Hz
Gain	--	17%
Peak User Spectral efficiency	9.0 bps/Hz	10.8 bps/Hz
Gain	--	20%

Discussion

- SNR measurements and SNR estimates distributions are analyzed and translated into achievable spectral efficiency for different scenarios
 - Measured SNR have been collected at cable modems for frequencies below 1 GHz, in several commercial plants
 - Estimated SNR are extracted from N+0 cable plant, modeled above 1 GHz
- Both measurements and estimates show that a **gain of ~17% to 43% in spectral efficiency and of 20% to 50% in peak data rate** can be achieved by adapting the modulation and coding scheme to the actual channel conditions of the user (group), as compared to a fixed MCS scheme
 - SNR variations among users in a plant are present in all frequency regions and they tend to be larger for higher portion of the spectrum
 - Mitigation could be done via plant upgrade to certain extent, but could be costly or not always possible in all locations – thus implying reduction of service penetration

Overall, multiple modulation and coding provides a flexible design to extract the most from a cable plant, guaranteeing the highest service quality and penetration

Discussion (cont.)

- Additional benefits can also be provided by selecting modulation and coding on a per user (or user group), as compared to pure broadcast approach:
 - The system can offer a higher peak data rate to users in good channel conditions or in frequency regions with better channel conditions
 - The system reliability is increased by adapting to the SNR conditions, as users that may suffer a degradation simply falls back into a lower data rate rather than being disconnected from the system
 - In case of broadcast, the degrading user will affect the entire plant average efficiency
 - The system can operate at lower margins in case of multiple MCS as the risk is just for reduced data rate – this also contributes to achieve higher performance

Considering tradeoffs of performance gains, easier operations and lower SNR margins, complexity and specification impact, the solution with MCS per user group is the best for EPoC downstream



Downstream Design Proposal

Design Overview

- The downstream channel conditions are assessed and reported by each user during the PHY negotiation procedure, for the EPoC channel in use
 - The collected information is provided to upper layers via MDIO
- The CLT maintain a table in which users are grouped according to their supported Modulation and Coding Scheme (MCS), which is used by MAC Control to determine the supported rate and regulate idle insertion
- The PHY at the CLT processes the transmit packets on a per-group base, so that packets belonging to the same user group can be encoded together
 - Stream based FEC applied to each group with large code words
 - MCS transitions optimized FEC efficiency by filling up the last code word as possible and eventually shortening it to free resources for the next group
 - A mapping of the OFDM symbol is included in the first part of the symbol (fixed robust MCS and reserved sub-carriers) to inform the receiver PHY in the CNU about how to decode incoming OFDM symbol and de-jitter packets
- The PHY at each CNU decodes the mapping of the incoming OFDM symbol and uses the information to process the related part in the PHY

Channel Quality Assessment and Report

- At power up, each CNU runs first a auto-negotiation procedure at PHY only to acquire and synchronize with the PHY at the CLT (see [3])
 - During this procedure downstream synchronization and configuration are achieved, after which the CNU is able to properly detect pilot signals
 - The CNU can use the pilot signal to assess the channel quality in the downstream channel of operation for EPoC and feed back the information to the CLT during the auto-negotiation procedure
 - Exact format is to be defined (e.g. highest supported MCS reported)
 - The information is transferred to MAC Control via MDIO and the CLT maintain a table in which each CNU in the plant is matched to the supported MCS – CNUs with same MCS are grouped together
 - Exact format is to be defined
- **When the PHY is in place and before MAC is activated, the channel quality information and CNU MCS is known at entities using it**

Channel Quality Assessment and Report (cont.)

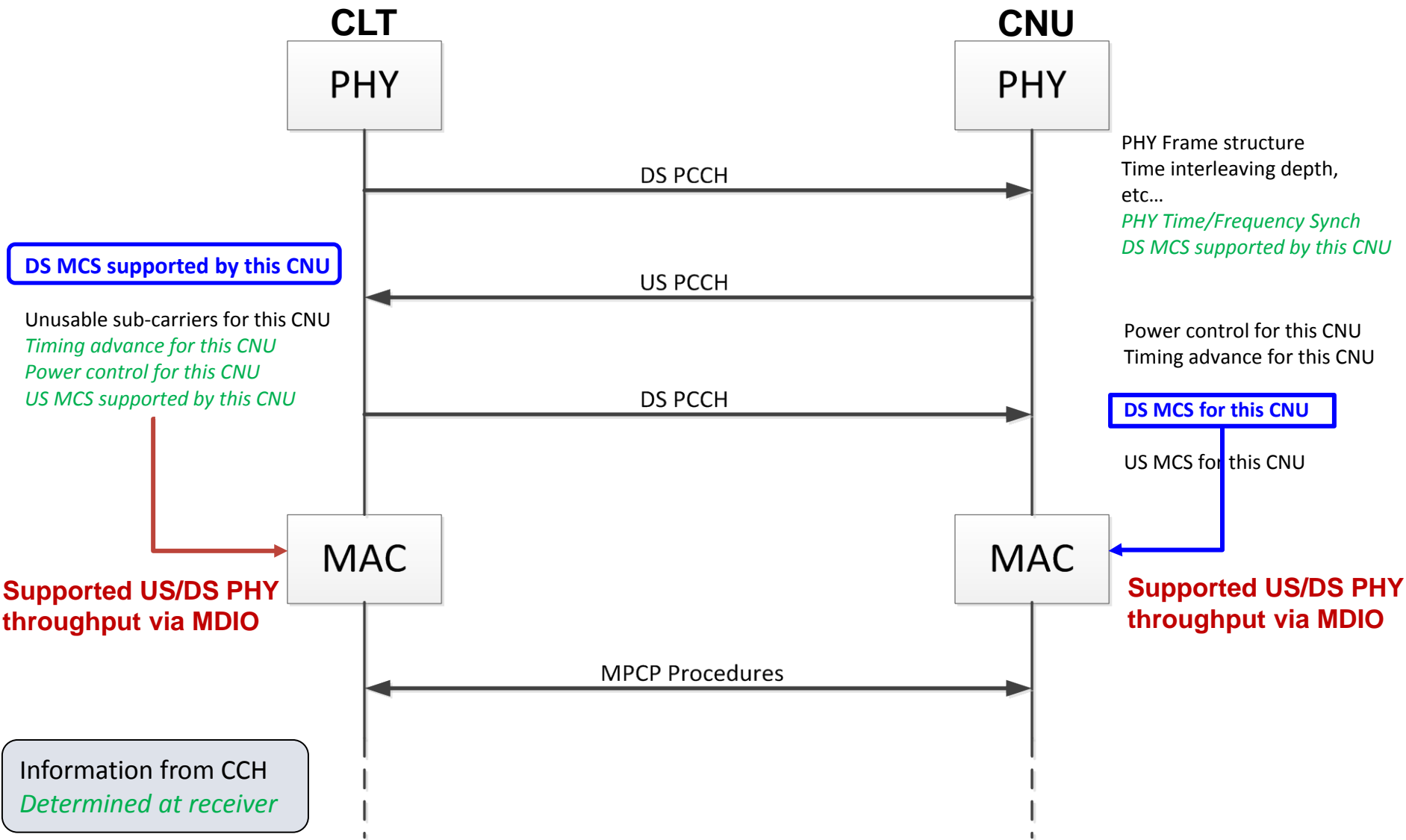

MAC-Control Operations

- For each packet to be transmitted, the MAC Control extracts from the MCS table the corresponding entry for the involved CNU
 - Depending on the MAC client which provides the packet, the CNU group is identified and the related MCS is read
 - Once the MCS is known, the corresponding data rate is calculated, which allows for the insertion of the correct number of idles after the packet (rate match)
- Note: This operation is the same if a single MCS is used in the plant, whereby here a table with more values is used (no complexity added)
 - Single MCS can still be supported as possible use case
- Number of MCS per plant: in practical deployments, a small number of groups (MCS) is sufficient to cover the range of typical SNRs
 - A range of e.g. 6-8 values can be included in the specification
 - In each plant, up to e.g. 4 groups can be configured at the time, choosing among those standardized values and a index/table can be used to identify them

PHY Operations – Grouping and Encoding

- To minimize FEC overhead, packets that are using the same MCS (i.e. for LLID pointing at CNU in the same group) are sent contiguously
 - Stream based FEC applied to each group, enable possible large code words
 - Group-to-group transition with optimized FEC efficiency by filling up the last code word as possible and eventually shortening it to free resources for the next group
 - MAC Control is aware of FEC formats to insert correct number of idles
 - The number of transitions is small (as the number of group in the plant is small)
- The grouping of packets can be performed
 - at MAC Control (e.g. via semi-static split of resources within a symbol, slowly adapting over time as traffic and groups change)
 - at PHY layer (e.g. distributing packets to the correct PHY processing chain based on their LLID – LLID maps uniquely into a MCS)
 - Both alternatives allows for single XGMII between MAC and PHY
- Broadcast traffic can be map into the group with smallest MCS, so that everybody can decode – similar concept could be used for multicast

PHY Operations – Grouping at MAC Control (new)

Sorting over interval T performed by the scheduler

*Note: sorting only applies among LLID flows
Order of packets in one LLID flow does not change*

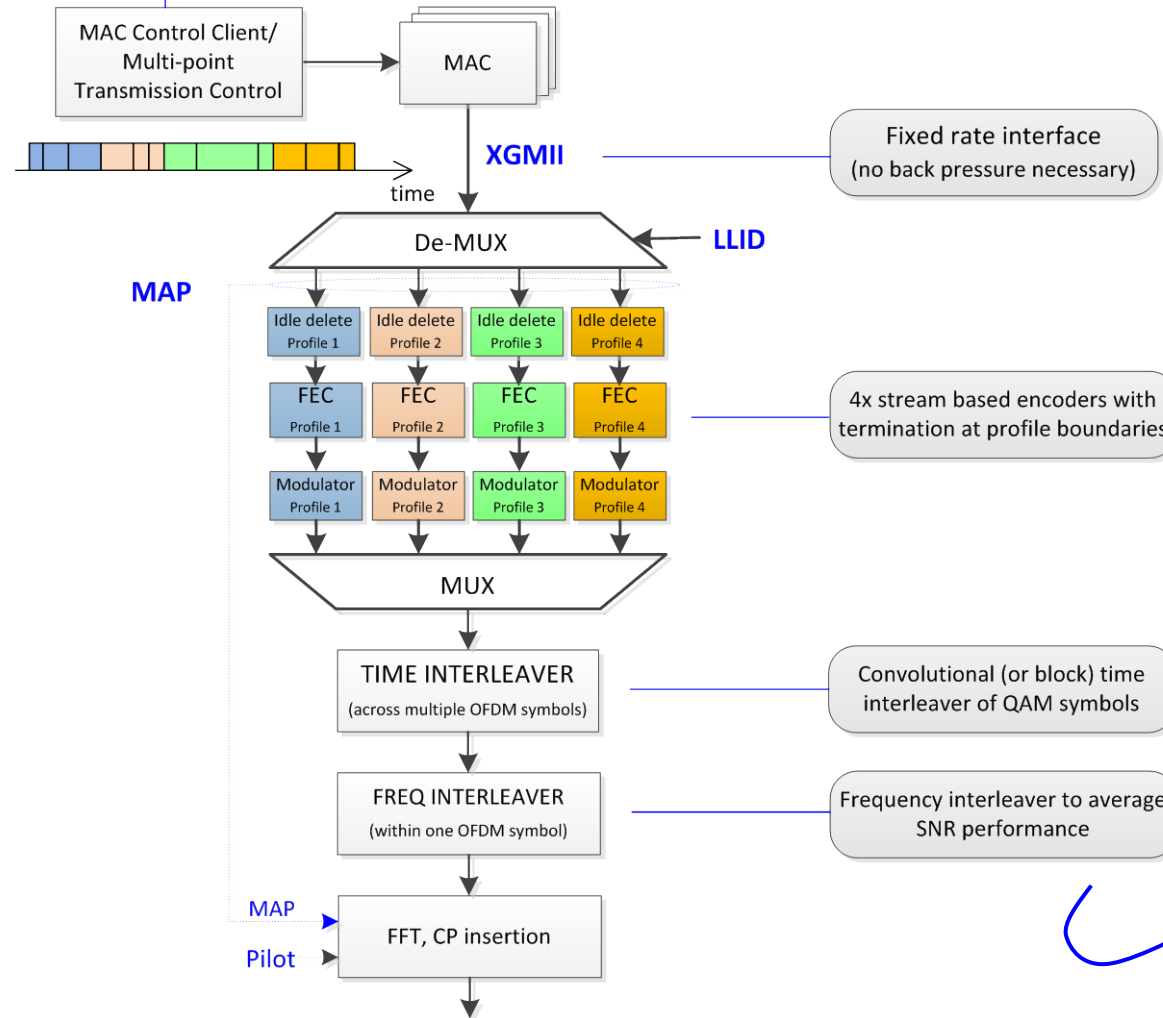

- Support of multiple groups via capability exchange
- Each group has fixed data rate (MCS), no backpressure needed
- Sorting applied at MAC Control over configurable interval – no impact on EPoC PHY delay budget

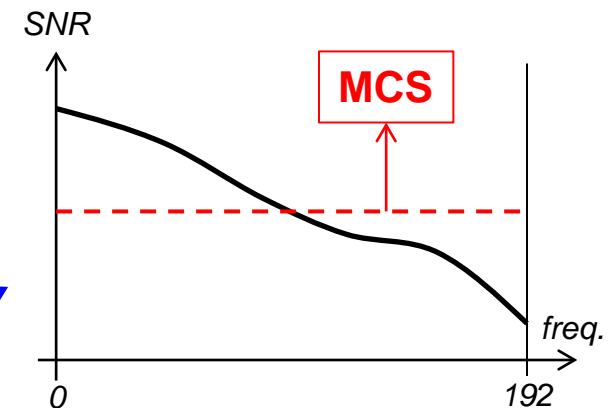

PHY Operations – FEC Efficiency (new)

FEC Efficiency Analysis - four profiles

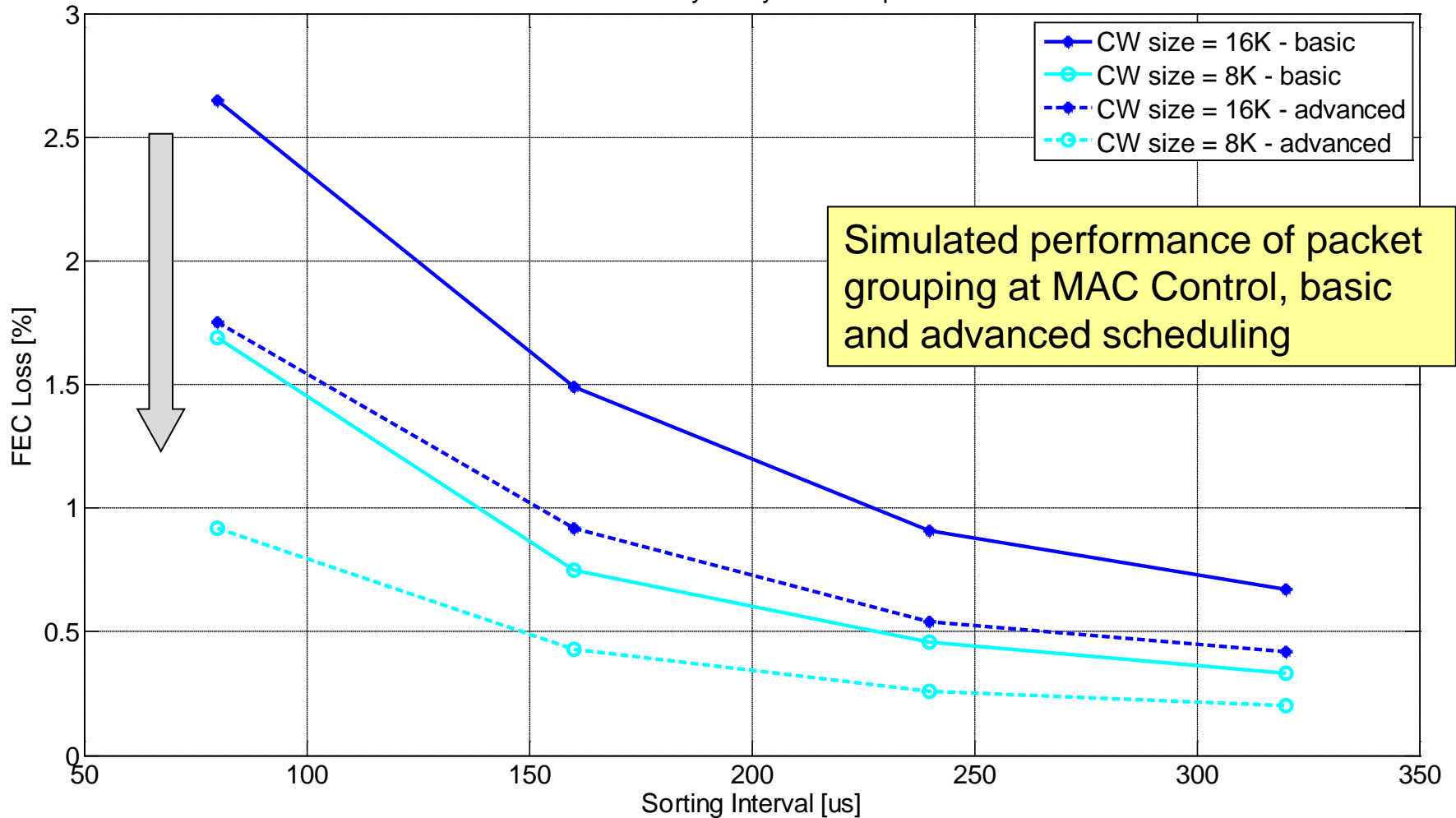

- The potential FEC losses are limited to less than 3% and can be further optimized and tuned via sorting interval and code word size configuration

PHY Operations – Interleaving

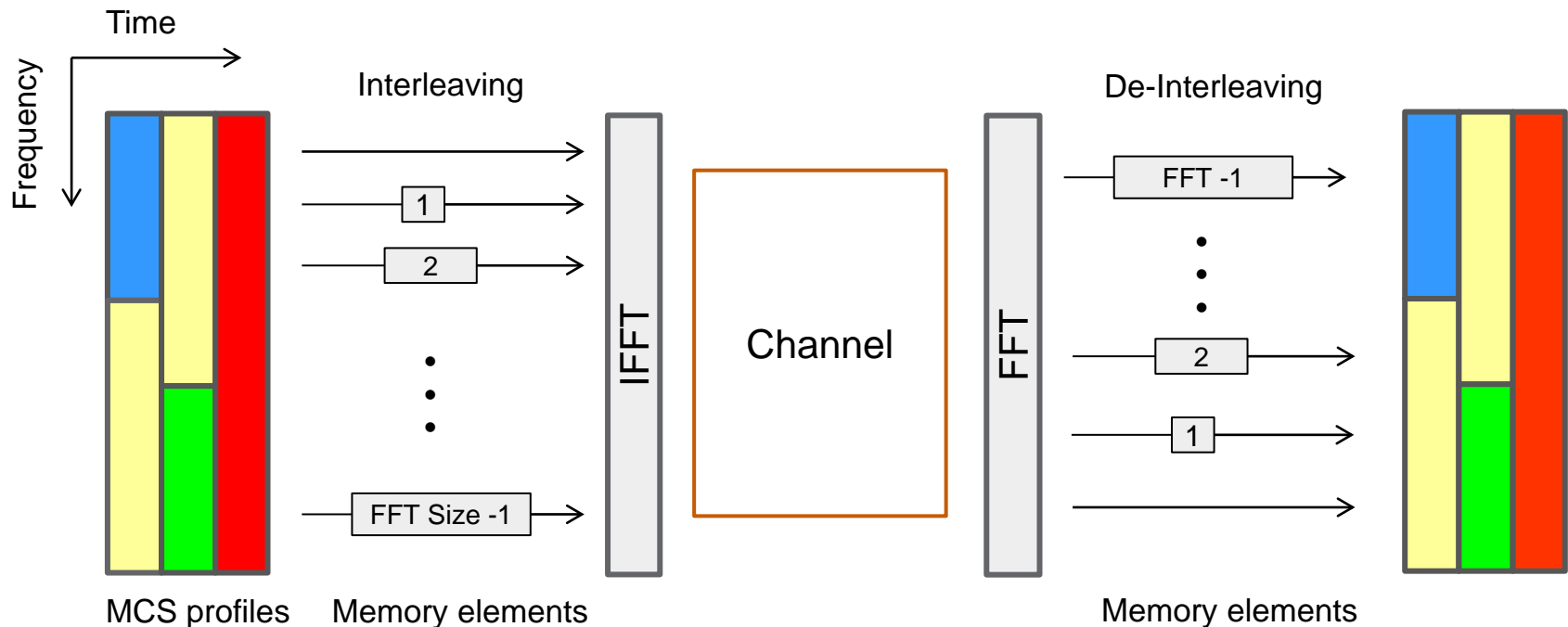

- Interleaving is applied at subcarrier level (QAM symbols) [4]
 - Convolutional interleaving delays each subcarrier in time (see figure)
- For a time-invariant channel, interleaving across MCS groups is possible for either block or convolutional design
- Delay and memory consumption can be optimized by parallel interleavers

PHY Operations – Symbol mapping

- In each symbol, additional information is added by the PHY layer to inform the receiver about the content of the OFDM symbol and how that can be demodulated and decoded correctly
 - Such mapping can be directly calculated in the PHY based on encoding
 - The mapping can be conveyed directly in the symbol, using a fixed and robust modulation and coding scheme and reserving a small fixed number of OFDM subcarriers in a precise position to ensure mapping is received by every CNU
 - This acts as PHY control channel for the receiver PHY
 - To limit overhead, group index pointing to the corresponding MCS can be used

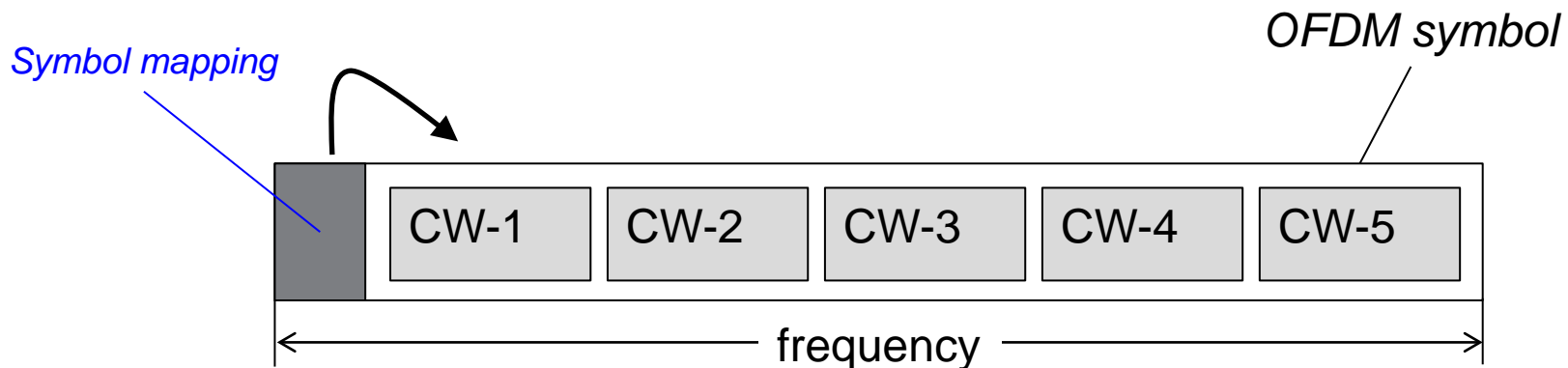

PHY Operations – Symbol mapping overhead (new)

- Symbol mapping indicates:
 - Profile index -> 2 bits allows up to 4 groups
 - Start/Stop subcarrier -> considering 16K FFT and 4 groups -> 112 bits
 - Use robust MCS to carry the symbol mapping
 - Code 1/2 -> double the number of bits to $2 * (2+112) = 228$ bits
 - 256 QAM (8 bits per QAM symbol) -> 28.5 subcarriers -> rounded to 32
 - Total overhead is 32 subcarriers per 16K symbol -> less than 0.2 [%]
- **Symbol mapping overhead is very small and constant**

CNU Reception

- The PHY at the CNU receiver first decodes the symbol map part in order to get instructions about what part of the OFDM symbol is of interest and where the corresponding code words are located in there
- All the code words for that group are decoded and all packets retrieved
 - PCS provides idle insertion (also) for packets which are not decoded
 - LLID is then used as usual to filter at RS what packets are for the CNU
 - No reordering of packet necessary within the same group
- Jitter handling:
 - In case the packet grouping is done at MAC Control, jitter is avoided
 - In case packet grouping is done at PHY, de-jittering may be necessary
 - An indication for the idle insertion function in the PCS could be used to control when to start sending a packet up to MAC over XGMII interface for jitter-free delivery
 - The indicator could be included in the OFDM symbol mapping from the transmitter, e.g. in the form of number of idles in which the related group was not sending packets

Conclusions (revised)

- A design proposal for multiple modulation and coding scheme in EPoC downstream has been illustrated
- The proposal adds very limited complexity in comparison to fixed MCS per plant, while achieving important benefits in terms of easier plant operations, automatic adjustment to (slowly varying) channel conditions and higher deliverable system throughput
- Preliminary analysis of performance shows low overhead and no added EPoC PHY delay or jitter is achieved via grouping packets at MAC Control level
 - Potential for further optimization has been shown too

Proposals (revised)

- It is proposed to adopt a per-CNU group modulation and coding scheme (MCS) for EPoC downstream operations
- The design described in slides 9 through 20 shall be used to develop a baseline for multiple modulation and coding scheme in downstream for EPoC



Thanks

References

- [1] **varanese_01_0912**: “Analysis on estimated SNR values on a generic cable plant” – Nicola Varanese, Andrea Garavaglia and Patrick Stupar (Qualcomm)
- [2] **stupar_01_1112**: “EPoC Feature Matrix and Specification Impact” – Patrick Stupar, Andrea Garavaglia and Juan Montojo (Qualcomm)
- [3] **boyd_01_0912**: “EPoC PHY Link and Auto-Negotiation” – Ed Boyd and Avi Kliger (Broadcom)
- [4] **pietsch_01_1112**: “OFDM Numerology” – Christian Pietsch and Juan Montojo (Qualcomm)



Appendix: SNR Analysis Details

Scope

- This appendix analyzes statistics on SNR measurements and SNR estimates on generic cable plants, based on typical architecture and real components characteristics
 - For real plants, SNR are measured at the cable modem below 1 GHz
 - For modeled plants each component is characterized in frequency and modeled accordingly for the analysis between 1.0 and 1.35 GHz and SNR values are estimated based on the plant and components model
- The model plant structure and characteristics are based upon authors understanding of what a generic EPoC plant will be
- Authors would like to gather feedback and opinion on the presented results

SNR measurements in current used spectrum

- Data from two different plants kindly provided by Comcast are considered for this analysis – each plant has about 240 cable modems
- SNR values are retrieved measurements at the cable modems, for spectrum below 1 GHz – SNR variability over frequency is within 2 dB

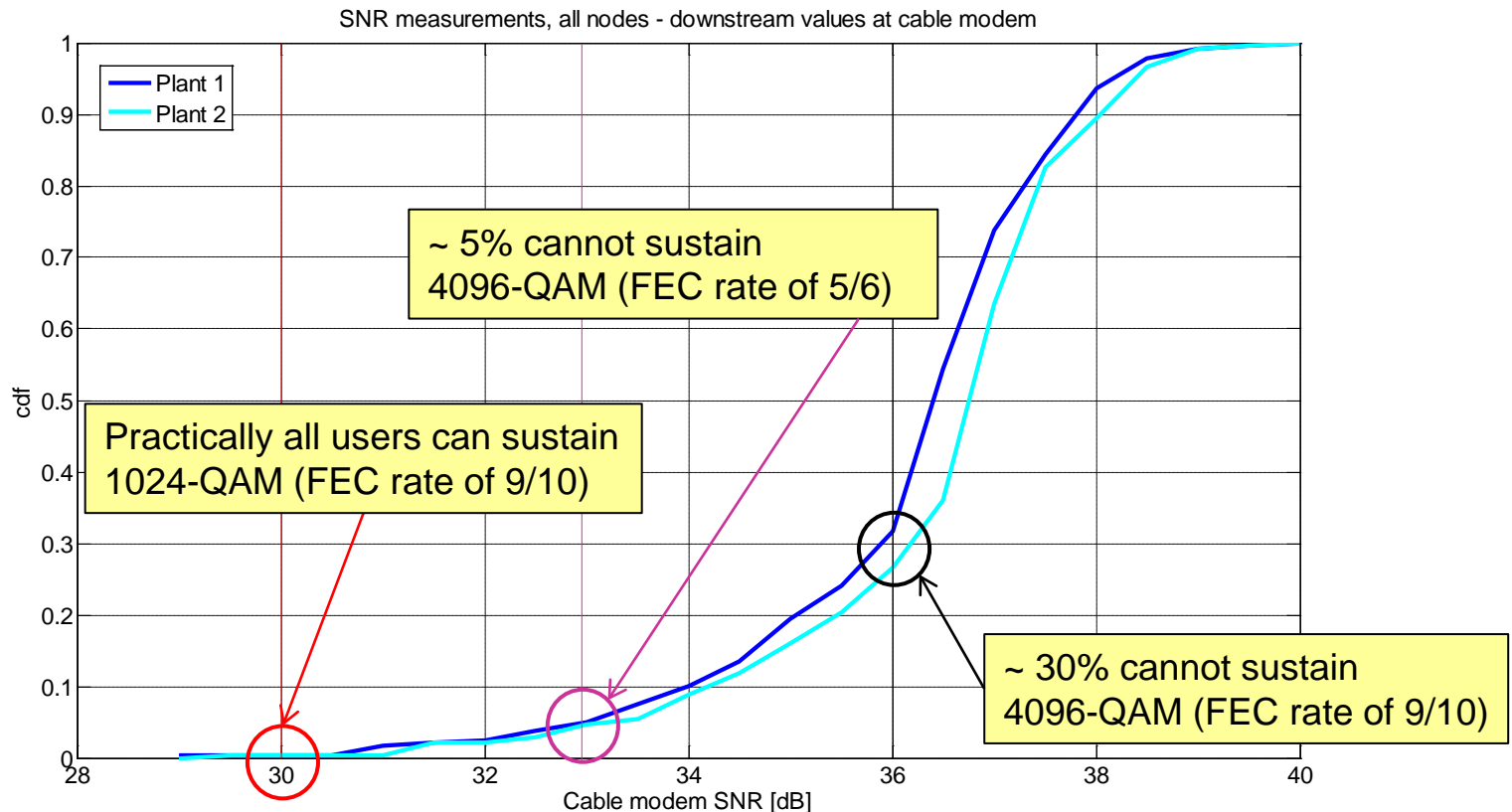

SNR measurements – discussion

- Assuming to adapt the modulation and coding scheme to the user SNR:
 - ~70% of the users can have 4096 QAM, FEC rate 9/10
 - ~25% of the users can have 4096 QAM, FEC rate 5/6
 - ~5% of the users can have 1024 QAM, FEC rate 9/10
 - Average spectral efficiency is 10.51 bps/Hz when all users are served
- Assuming to serve every user with the same modulation and coding scheme of 1024 QAM and FEC rate 9/10 is the choice:
 - Average spectral efficiency is 9 bps/Hz and all users are served
 - Peak data rate is reduced of 20% compared to adapting the modulation and coding

When serving all users and without considering any SNR degradation margin, a **gain of ~17% in spectral efficiency and of 20% in peak data rate** can be achieved by adapting modulation and coding scheme to the user SNR

Cable plant model – a typical scenario

- For spectrum above 1 GHz, no measurements are available and modeling of the plant based on real components characteristics have been done
- A generic passive plant (i.e. N+0) has been considered for the analysis
- The plant includes different cable types, as well as couplers, splitters and tabs, each of them fully characterized in frequency
 - Components are linked together in the cable plant model
 - About 140 subscribers ports are considered in the analysis
 - Thermal noise and micro-reflections have been considered
 - A transmit power level of 65 dBmV have been considered
 - Corresponding to a constant Power Spectral Density of about -69 dBm/Hz
 - Considered spectrum is from 1000 to 1350 MHz, which is a possible candidate of interest for EPoC deployment at high capacity
 - For lower frequency spectrum, the SNR tends to flatten to high values
 - In the upper region instead, components upgrade or other alternatives shall be considered to make a good use of the plant

Evaluation method and analysis

- The spectrum has been divided into 128 frequency chunks and for each of the chunk the downstream SNR at the subscriber port has been estimated
- Statistics of the obtained estimated SNR values have been calculated for the following spectrum regions and represented in terms of CDF
 - 1000 – 1350 MHz – entire spectrum considered (128 chunks)
 - 1000 – 1100 MHz – lower 100 MHz region
 - 1000 – 1200 MHz – lower 200 MHz region
- In addition, average spectral efficiency is derived from estimated SNRs
 - based on simulated performance of LDPC FEC codes
 - the spectral efficiency is averaged over the considered spectrum region

SNR estimates – frequency characteristics

SNR characteristics - N+0 plant, all subscriber ports

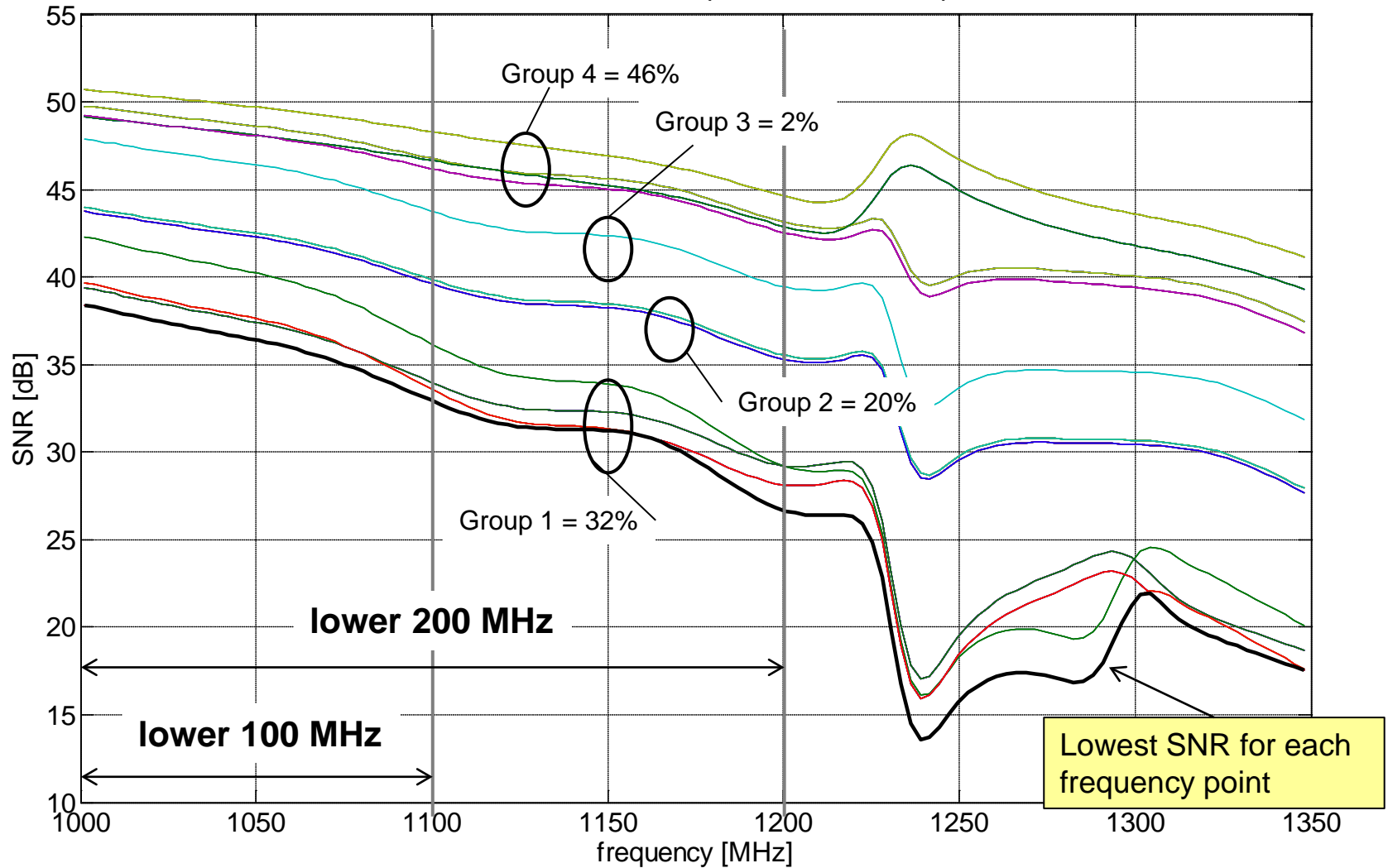

SNR distribution – all values

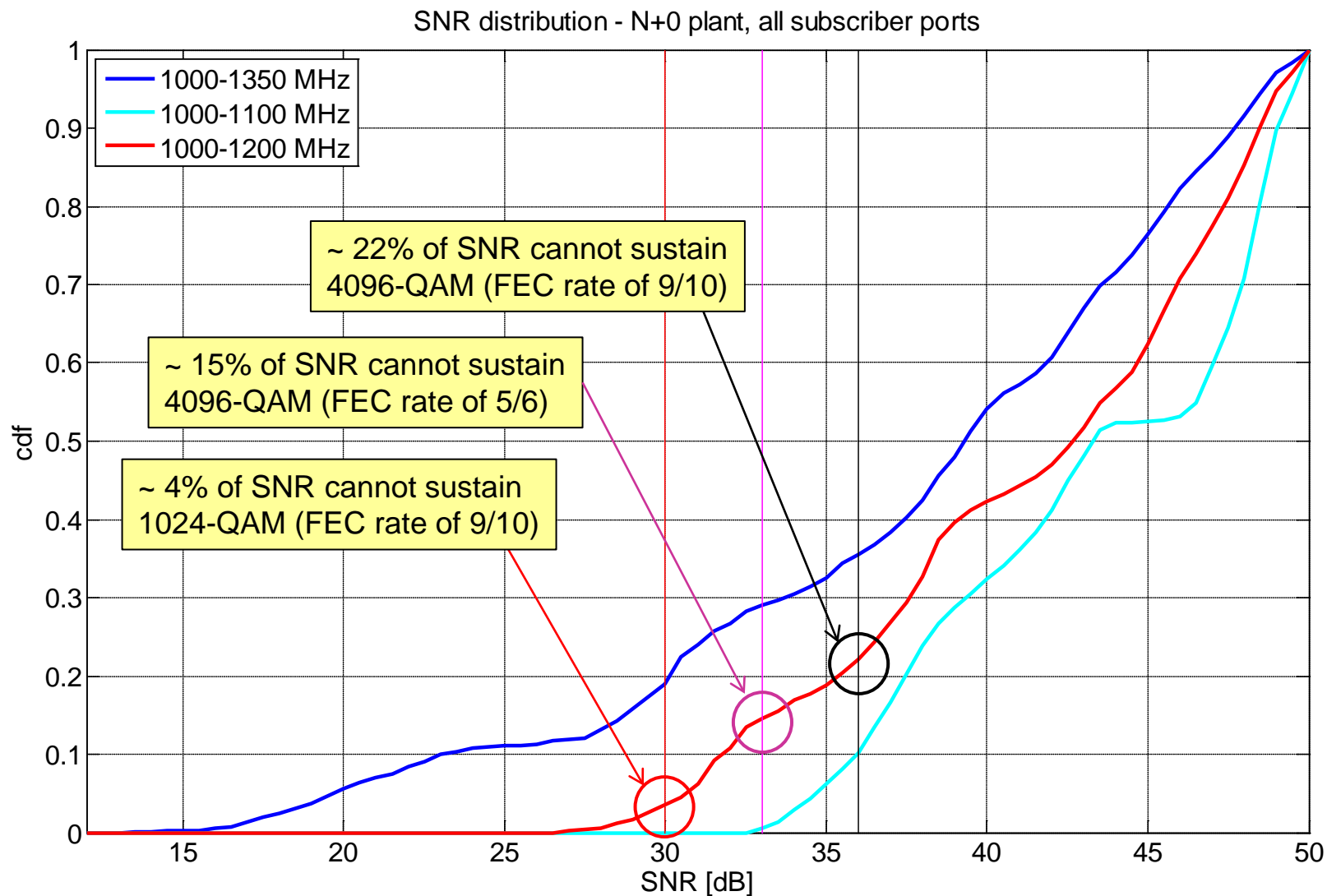

SNR distribution – worse SNR per CNU

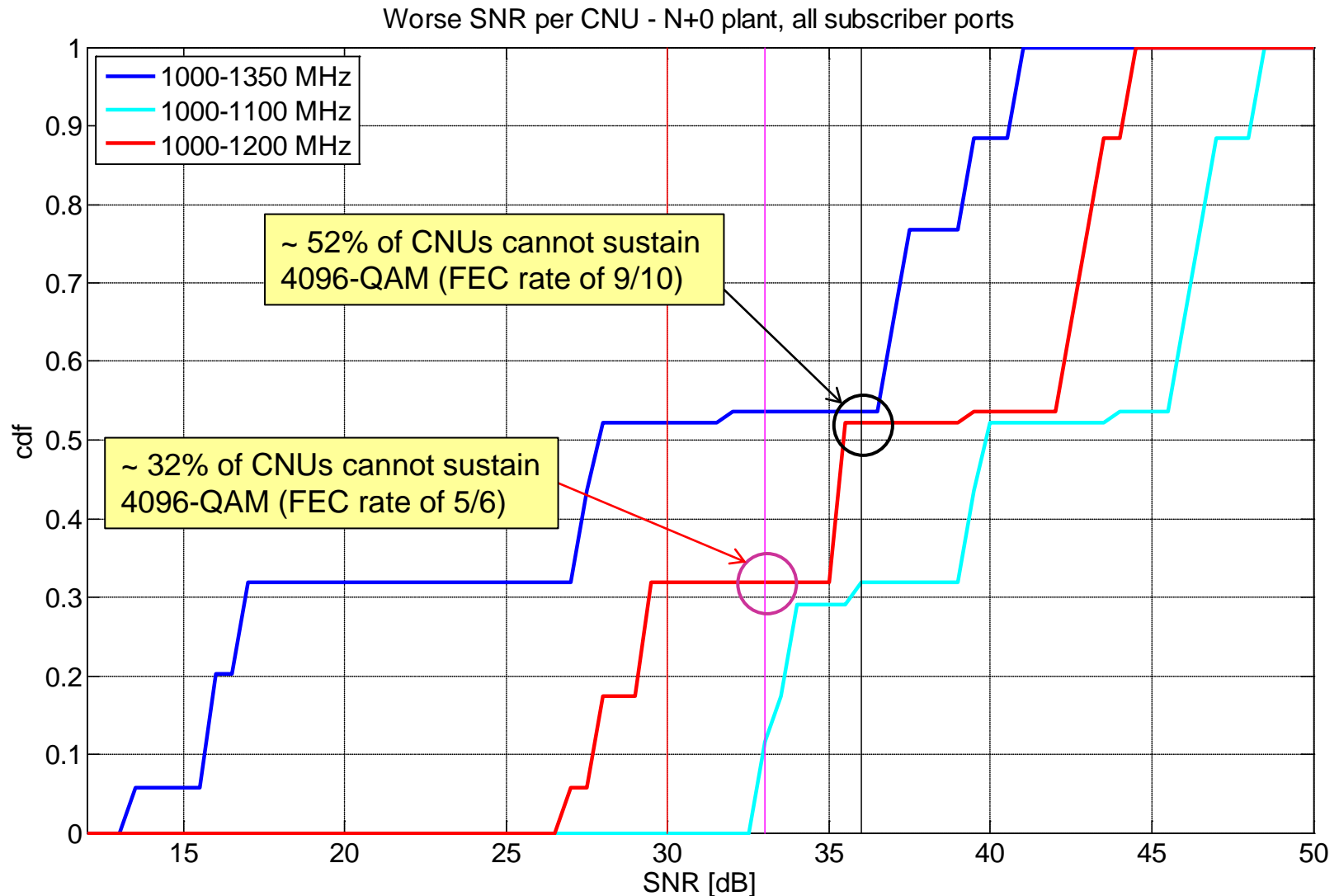

SNR distribution – worse SNR per CNU group

Worse SNR per CNU group - N+0 plant, group 1 subscribers

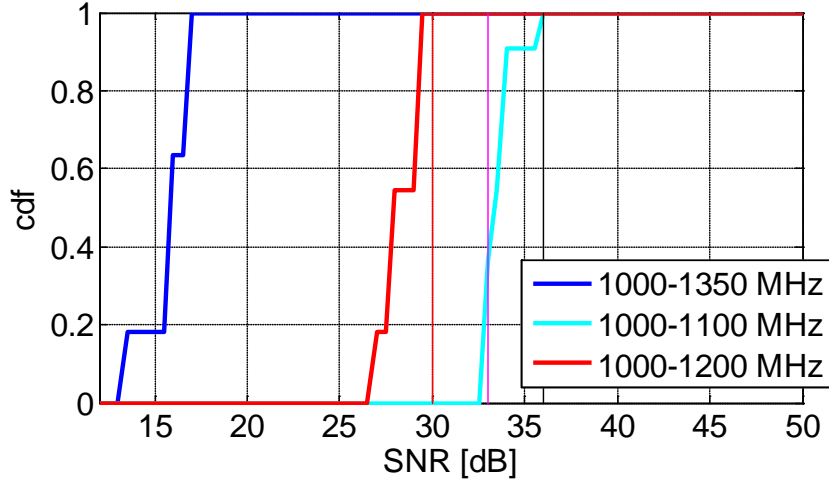

Worse SNR per CNU group - N+0 plant, group 2 subscribers

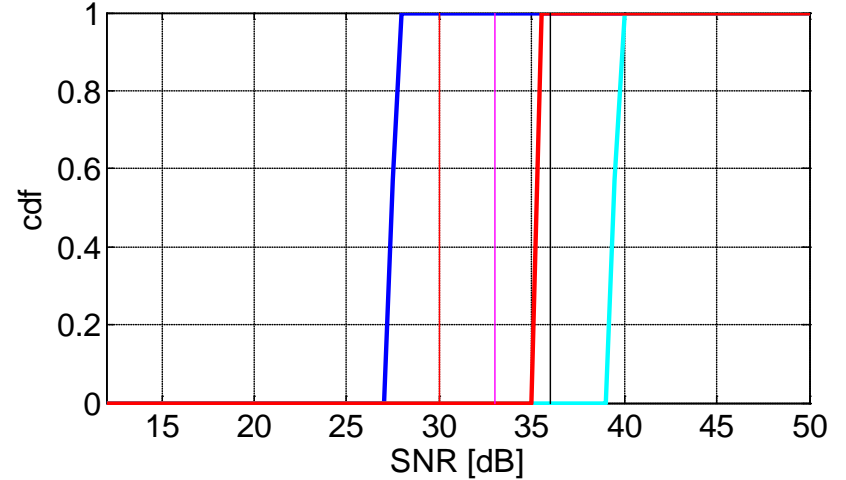

Worse SNR per CNU group - N+0 plant, group 3 subscribers

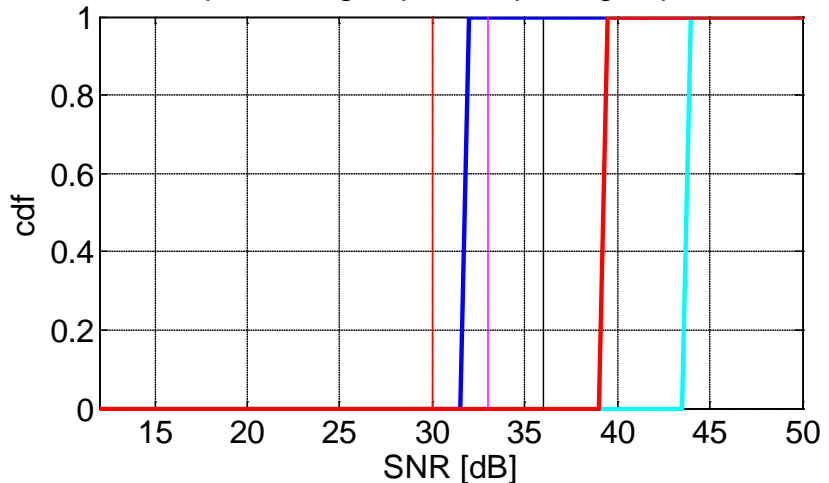

Worse SNR per CNU group - N+0 plant, group 4 subscribers

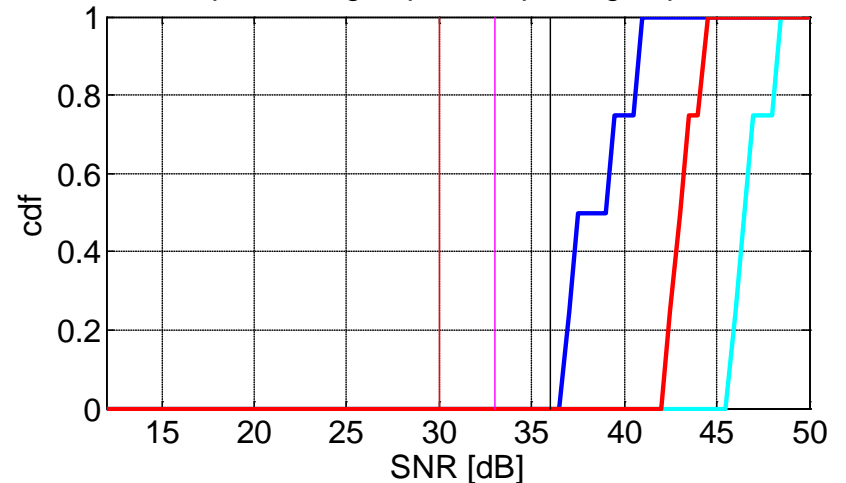

SNR distribution – worse SNR per frequency chunk

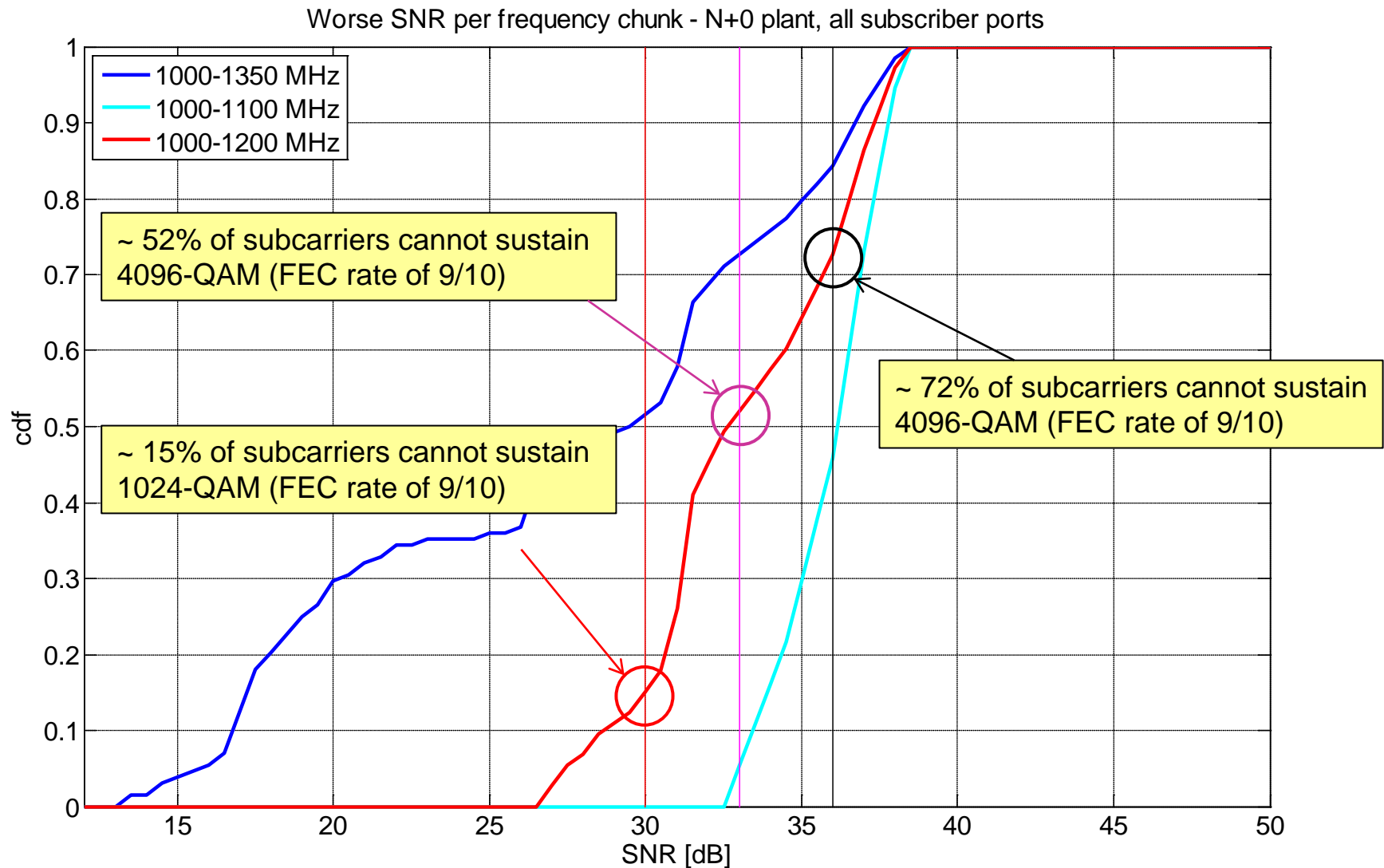

SNR distribution – worse SNR per CNU group and frequency chunk

Worse SNR per CNU group and frequency chunk - N+0 plant, group 1 subscribers

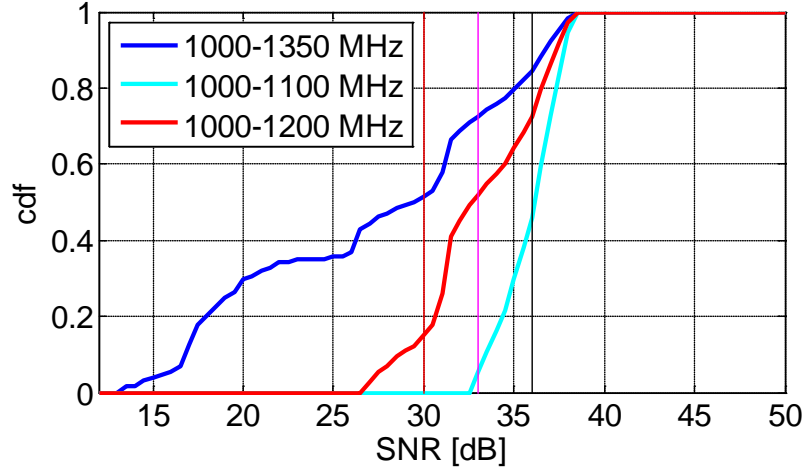

group 2 subscribers

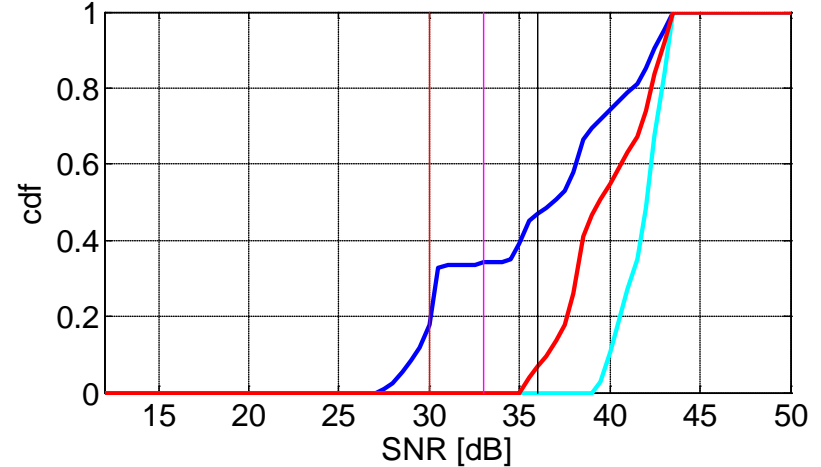

group 3 subscribers

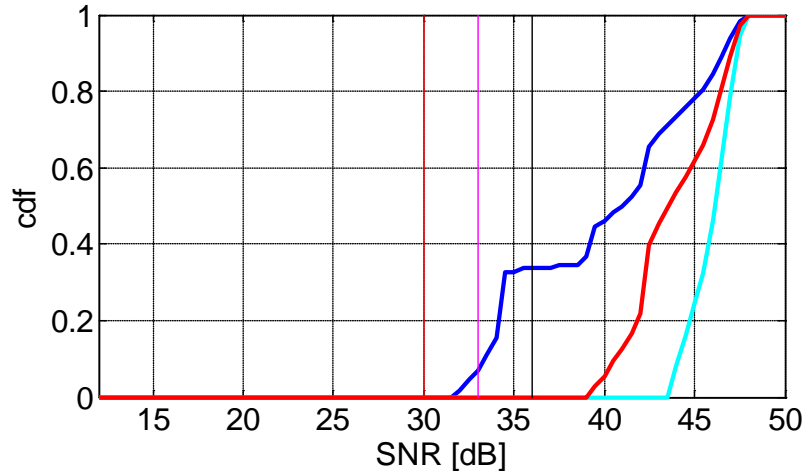

group 4 subscribers

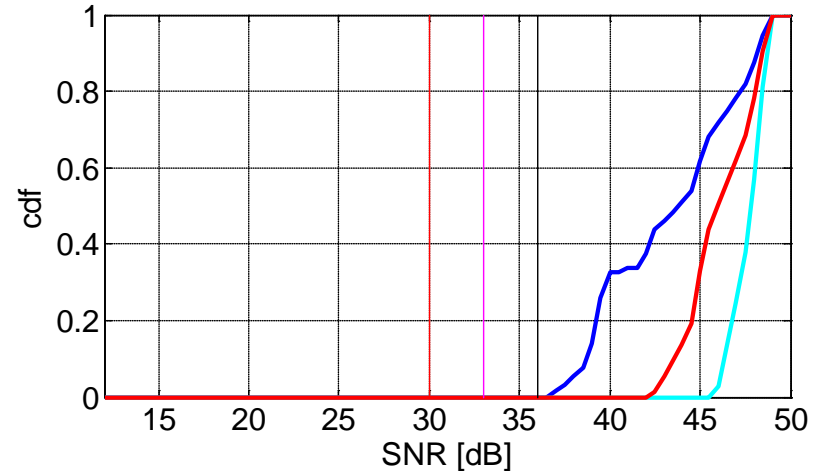

SNR estimates – discussion

- Assuming to adapt the modulation and coding scheme to the user SNR:
 - ~48% of the users can have 4096 QAM, FEC rate 9/10
 - ~20% of the users can have 4096 QAM, FEC rate 5/6
 - ~32% of the users can have 256 QAM, FEC rate 9/10
 - Average spectral efficiency is 9.5 bps/Hz when all users are served
 - The value would increase to 10.4 bps/Hz if only the lower 100 MHz region is used

- Assuming to adapt the modulation and coding to the frequency SNR curve:
 - ~28% of the sub-carriers can have 4096 QAM, FEC rate 9/10
 - ~20% of the sub-carriers can have 4096 QAM, FEC rate 5/6
 - ~37% of the sub-carriers can have 1024 QAM, FEC rate 9/10
 - ~15% of the sub-carriers can have 256 QAM, FEC rate 9/10
 - Average spectral efficiency is 9.4 bps/Hz when all users are served
 - The value would increase to 10.2 bps/Hz if only the lower 100 MHz region is used

SNR estimates – discussion (cont.)

- Assuming to adapt the modulation and coding scheme to the user SNR on a per frequency base:
 - ~78% of the users can have 4096 QAM, FEC rate 9/10
 - ~8% of the users can have 4096 QAM, FEC rate 5/6
 - ~9% of the users can have 1024 QAM, FEC rate 9/10
 - ~5% of the users can have 256 QAM, FEC rate 9/10
 - Average spectral efficiency is 10.4 bps/Hz when all users are served
 - The value would increase to 10.72 bps/Hz if only the lower 100 MHz region is used

- Assuming to serve every user with the same modulation and coding scheme of 256 QAM and FEC rate 9/10 seems good compromise:
 - Average spectral efficiency is 7.2 bps/Hz and all users are served – peak data rate is reduced of 50% compared to adaptive case
 - The value would increase to 9 bps/Hz if only the lower 100 MHz region is used

SNR Analysis - Summary

SNR Estimates	Broadcast		Unicast	
	Common MCS (reference)	Bit loading	Single MCS per user	Bit loading per user
Average spectral efficiency	7.2 bps/Hz	9.4 bps/Hz	9.5 bps/Hz	10.4 bps/Hz
Gain	--	30%	32%	44%
Peak User Spectral efficiency	7.2 bps/Hz	9.4 bps/Hz	10.8 bps/Hz	10.8 bps/Hz
Gain	--	30%	50%	50%

SNR Measurements	Broadcast – Common MCS	Unicast – single MCS per user
Average spectral efficiency	9.0 bps/Hz	10.5 bps/Hz
Gain	--	17%
Peak User Spectral efficiency	9.0 bps/Hz	10.8 bps/Hz
Gain	--	20%

SNR Analysis – Summary (cont.)

SNR Estimates	Broadcast per plant		Broadcast per user group	
	Common MCS (reference)	Bit loading	Single MCS per user group	Bit loading per user group
Average spectral efficiency	7.2 bps/Hz	9.4 bps/Hz	9.5 bps/Hz	10.3 bps/Hz
Gain	--	30%	32%	43%
Peak User Spectral efficiency	7.2 bps/Hz	9.4 bps/Hz	10.8 bps/Hz	10.8 bps/Hz
Gain	--	30%	50%	50%

SNR Measurements	Broadcast per plant – Common MCS	Broadcast per user group – single MCS per user group
Average spectral efficiency	9.0 bps/Hz	10.5 bps/Hz
Gain	--	17%
Peak User Spectral efficiency	9.0 bps/Hz	10.8 bps/Hz
Gain	--	20%