

# Common Mode Noise on an Automotive Dataline

Stefan Buntz, Daimler AG

# Supporters

Kirsten Matheus, BMW

Mehmet Tazebay, Broadcom

Gavin Parnaby, Marvell

Mike Gardner, Molex

Stefano Valle, STMicroelectronics

Dave Dwelley, Linear Technology

Steve Carlson, High Speed Design Inc.

Jeff Heath, Linear Technology

Todd Herman, Commscope

Dave Estes, UNH

Curtis Donehue, UNH

Sasha Babenko, Molex

# motivation and background

- Measurement of typical common mode noise on automotive data lines/supply lines in laboratory environment (vehicle generated noise).
- This is as an input for the chip development for 802.3bp.
- **Remark:**
- Keep in mind, that the stationary noise of the vehicle itself is just one part of the noise environment. Beside the vehicle generated noise there is additional environmental noise (radio stations, ..., cell phones), which can be coupled to the vehicle data lines, if a vehicle is in a noisy environment (e.g. besides a radio station or a airport/radar station). For modelling these external noise sources the worst case scenarios are the defined component level EMC tests for automotive
- BCI-test with a common mode current of  $106\text{dB}\mu\text{A} = 200\text{mA}$  on the cable harness (trucks and buses require  $114\text{dB}\mu\text{A} = 500$ )  
→ see appendix A
- DPI-test with a common mode of  $39\text{dBm}$  on the data line.

# measurement setup

a) position of clamp, different vehicle states:

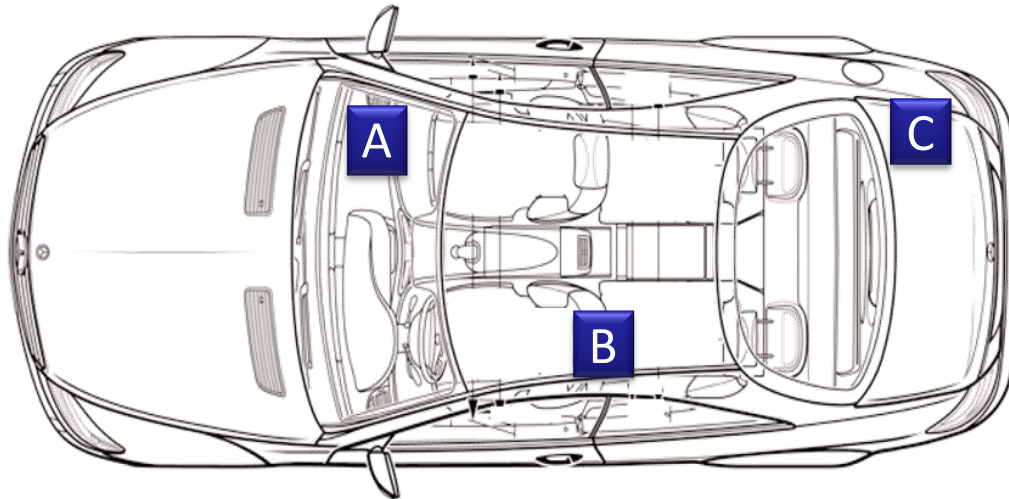

position	system
A	CAN data line in footroom of passenger seat
B	CAN data line beneath driver's seat at can star coupler
C	CAN data line in trunk (right side)
C2	GROUND wire on ECU

Vehicle state	description
(IGNITION) OFF	vehicle off, key removed (=NOISEFLOOR)
(IGNITION) ON	Ignition ON (key on IGNITION position), engine not running
RUNNING	Engine running
START	Starting engine (key on START position) *)

\*) During measurement sweep engine is started and switched off several times with „maxHOLD“ function of multiple measurement sweeps

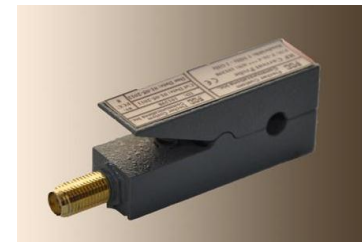

used current clamp:  
FCC F 36-4

# measurement setup

## b) Pictures of measurement setup

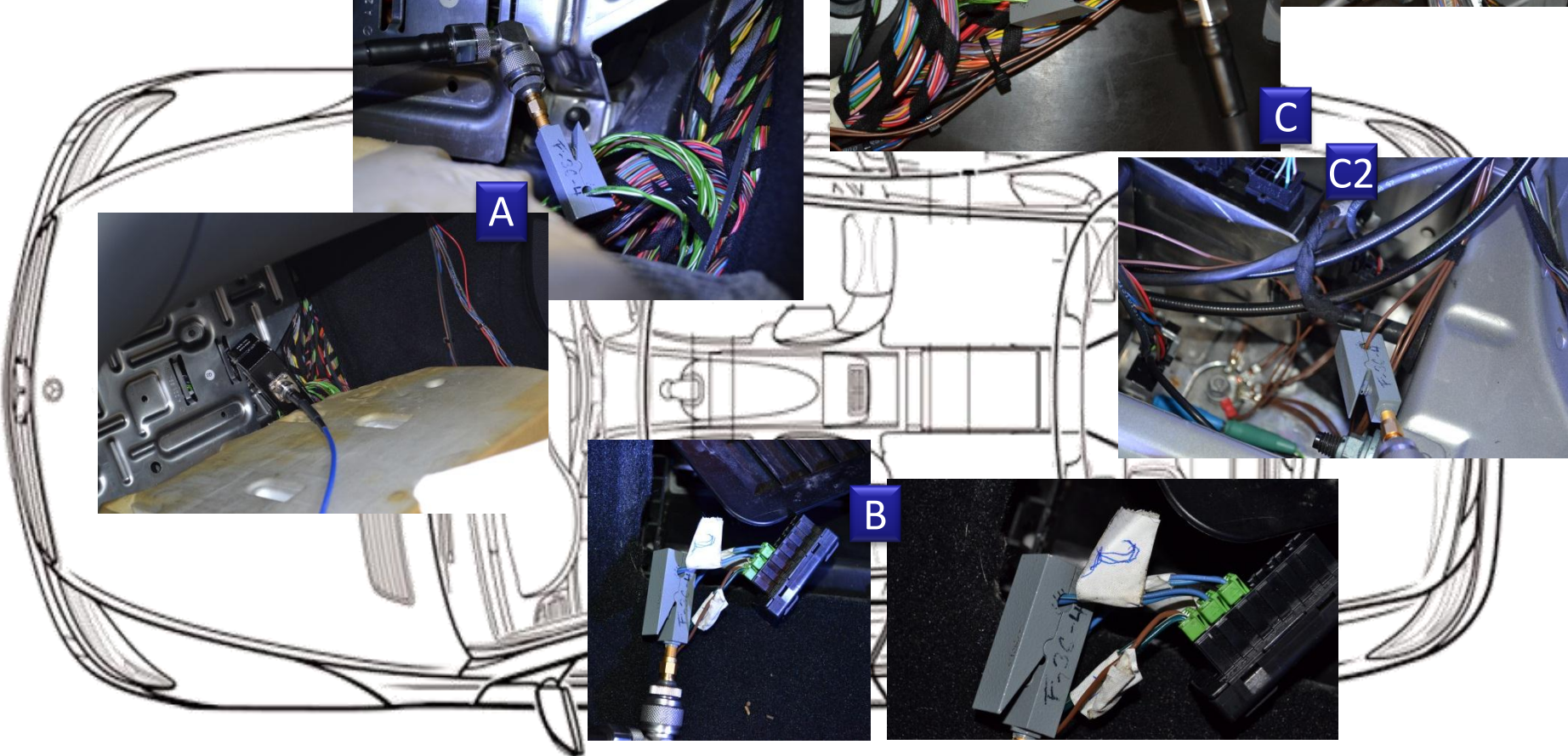

# measurement setup (cont')

## c) Spectrum analyzer settings + cable

- For the shown measurements a Rohde&Schwarz FSU8 is used with the shown settings („HF sweep“). Here only the HF-sweep results of the maxPeak detector are presented.
- For connecting the current clamp a 4m coaxial SMA cable is used, which has a measured maximum insertion loss of 1,12dB@1GHz (this insertion loss is also corrected with the clamp calibration).

See also comments  
in appendix B

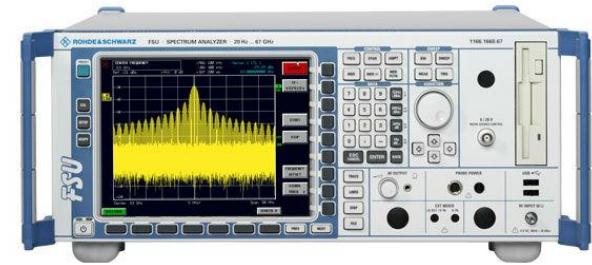

parameter	setting (HF sweep)
Start frequency	DC
stop frequency	1GHz
Sweep time	100ms
Number of sweeps	1000
RBW	100kHz
VBW	1MHz
detector	Max peak
EMI filter	Normal (3dB)
result format	dBμV
trace	maxHold

Setting	f <sub>Start</sub>	f <sub>Stop</sub>	RBW	VBW	SWT	RefLvL	ATT	PTS	Detector, EMI Filter	Trace
HF-sweep	DC	1GHz	100kHz	1MHz	100ms	115dBμV	5dB	10.001	AV and maxPK, Normal (3dB)	maxHold, >1000 sweeps
LF-sweep	DC	100MHz	10kHz	100kHz	1s	115dBμV	5dB	10.001	AV and maxPK, Normal (3dB)	maxHold, >100 sweeps

# measurement setup (cont')

## d) Calibration and calculation of dBm/Hz

### 1. Calculation of Noise Floor (NF) from Spectrum Analyzer result (de- calibration of current clamp and coaxial measurement cable)

- M = measurement result of spectrum analyzer (dBμV) with RBW (resolution band width)  
 RBW = resolution bandwidth of spectrum analyzer (set to 1MHz)  
 C = calibration measurement of coupling clamp including cable in 50ohm system /  $s_{31}$  (dB)  
 (you need some cable length to reach different points inside the vehicle)  
 $Z_T$  = Transfer impedance of coupling in system [ $s_{31} * \text{SQRT}(Z_0 * Z_L) = C * \text{SQRT}(Z_0 * Z_L)$ ]  
 $Z_0$  = measurement system impedance (50ohms)  
 $Z_L$  = common mode impedance of measured line ( $Z_L = 25\text{ohms} \dots 300\text{ohms}$ ), here 50ohms

#### 2. Calculation of common mode current on the measured line

$$I_{CM}[\mu A] = \frac{M[\mu V]}{Z_T[\Omega]} = \frac{M[\mu V]}{s_{31} * \sqrt{Z_0 * Z_L}} = \frac{M[\mu V]}{C * \sqrt{Z_0 * Z_L}}$$

$$I_{CM} [dB\mu A] = 20 * \log\left(\frac{M[\mu V]}{C * \sqrt{Z_0 * Z_L}}\right) = M[dB\mu V] - C[dB] - 20 * \log(\sqrt{Z_0 * Z_L})$$

#### 3. Calculation of common mode noise on line

$$NF[dBm/Hz] = NF_{RBW} [dBm] - 10 * \log(RBW) = (I_{CM} [dB\mu A] + 10 * \log(Z_L) - 90dB) - 10 * \log(RBW)$$

$$NF[dBm/Hz] = \left( (M[dB\mu V] - C[dB] - 20 * \log(\sqrt{Z_0 * Z_L})) + 10 * \log(Z_L) - 90 \right) - 10 * \log(RBW)$$

$$NF[dBm/Hz] = M[dB\mu V] - C[dB] - 10 * \log(Z_0) - 10 * \log(Z_L) + 10 * \log(Z_L) - 90 - 10 * \log(RBW)$$

$$NF[dBm/Hz] = M[dB\mu V] - C[dB] - 10 * \log(Z_0) - 90 - 10 * \log(RBW)$$

$$NF[dBm/Hz] = M[dB\mu V] - C[dB] - 17 - 90 - 60 = M[dB\mu V] - C[dB] - 167$$

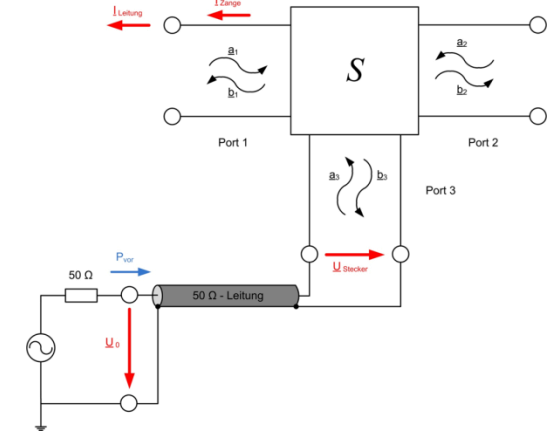

# emission

Overall emission results on all positions of the car, when „IGNITION ON“ and engine not running

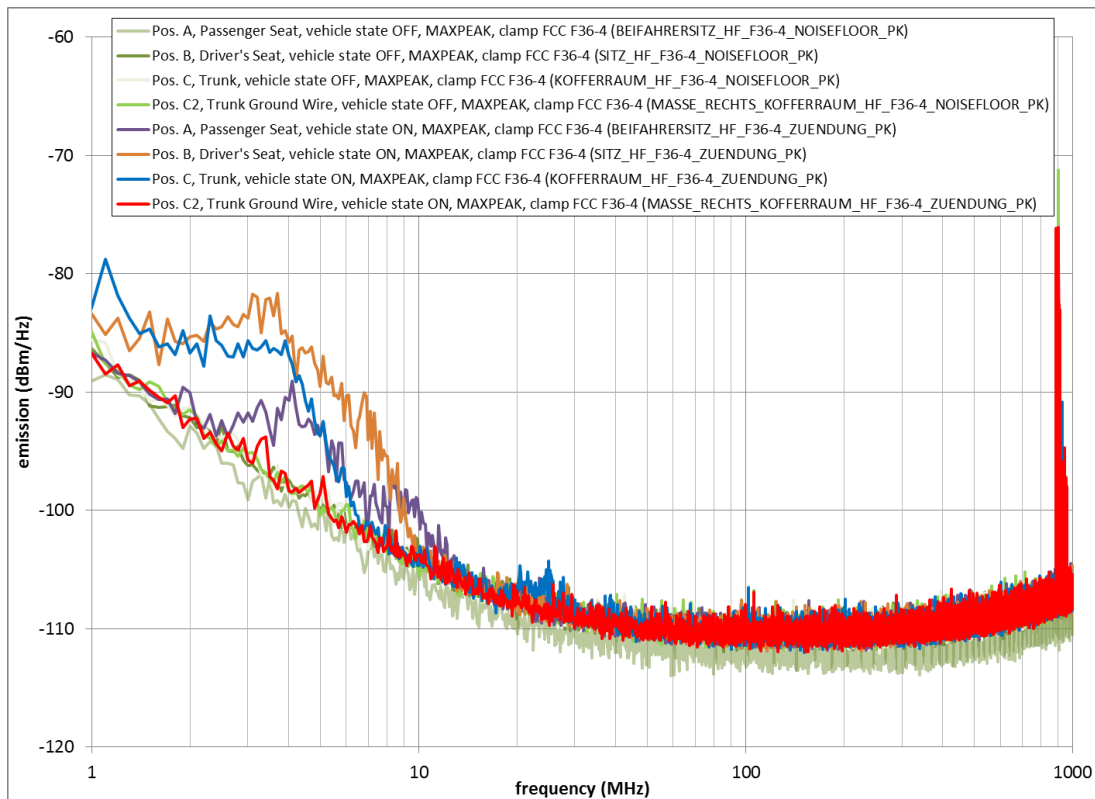

parameter	value
vehicle	MB S500 (BB DC 562)
Spectrum analyzer settings	„HF-sweep“
Position	All (A,B,C,C2)
Vehicle state	OFF and ON

emission on CAN data line on all positions (driver's seat, passenger seat, trunk) and on a GND wire in trunk.



# emission

Overall emission results on all positions of the car, when „IGNITION ON“ and engine is running

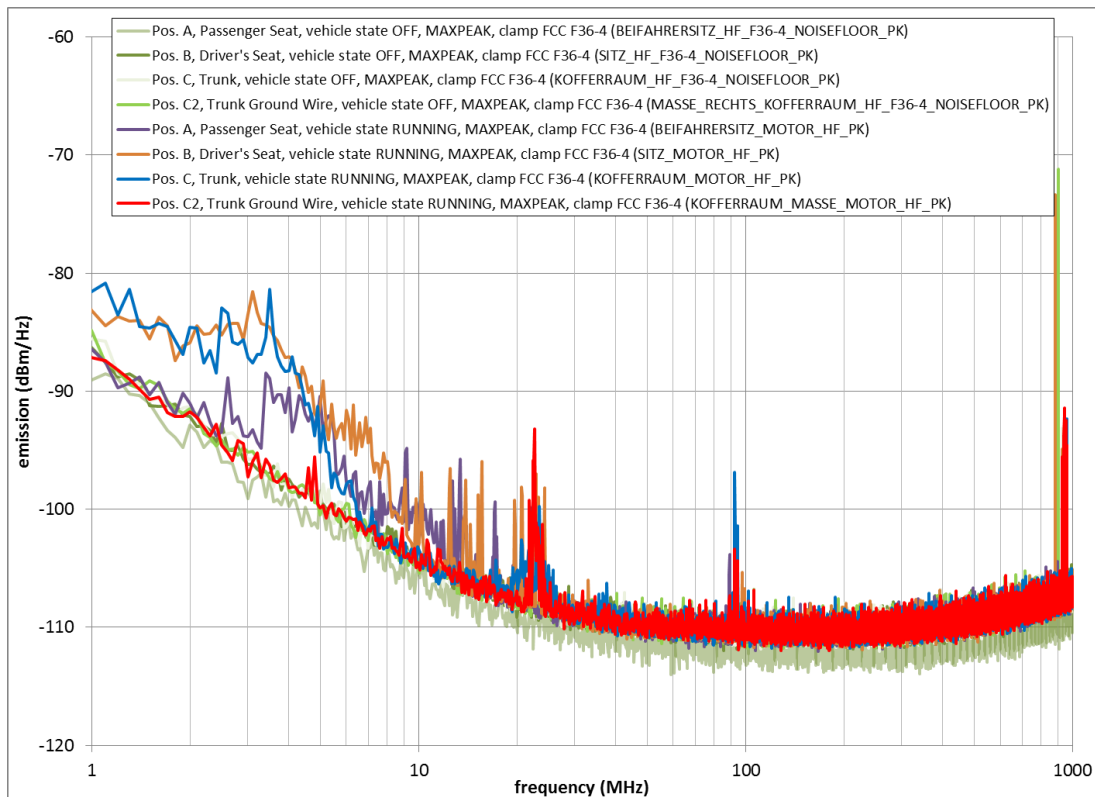

parameter	value
vehicle	MB S500 (BB DC 562)
Spectrum analyzer settings	„HF-sweep“
Position	All (A,B,C,C2)
Vehicle state	OFF and RUNNING

emission on CAN data line on all positions (driver's seat, passenger seat, trunk) and on a GND wire in trunk.

# emission

Overall emission results on all positions of the car, when vehicle is started.

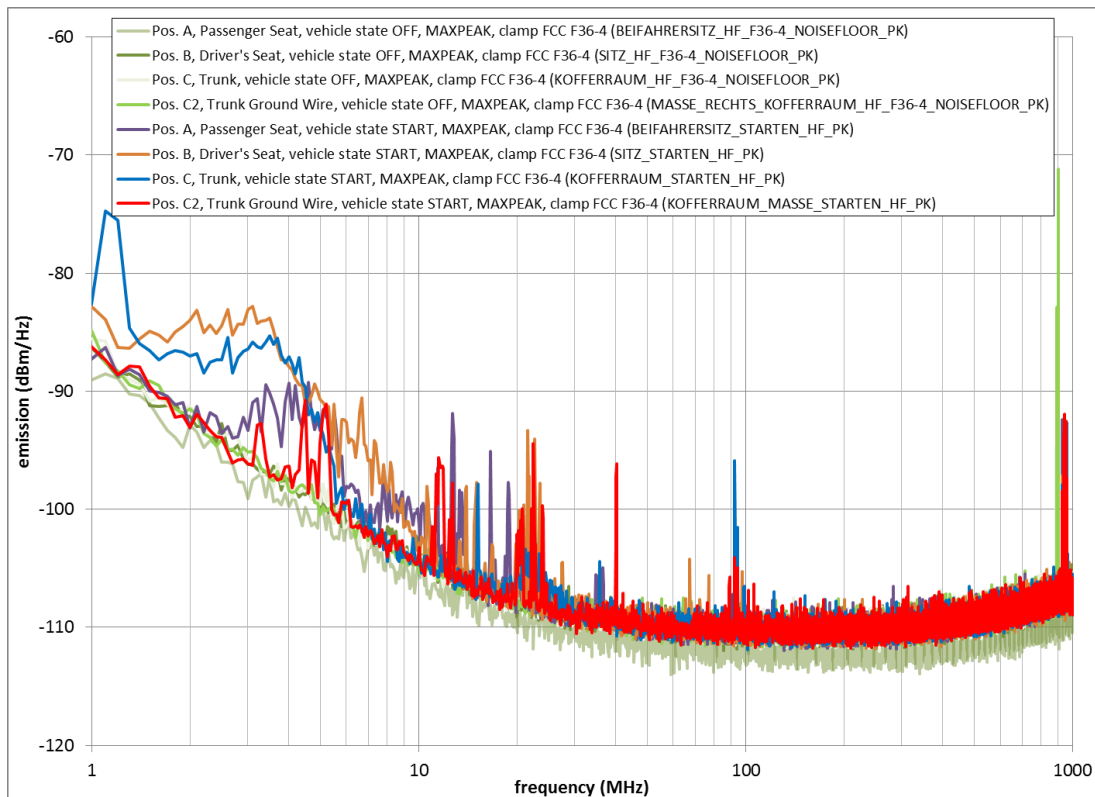

parameter	value
vehicle	MB S500 (BB DC 562)
Spectrum analyzer settings	„HF-sweep“
Position	All (A,B,C,C2)
Vehicle state	OFF and START

emission on CAN data line on all positions (driver's seat, passenger seat, trunk) and on a GND wire in trunk.

# emission

Overall emission results on all positions of the car, when vehicle is started.

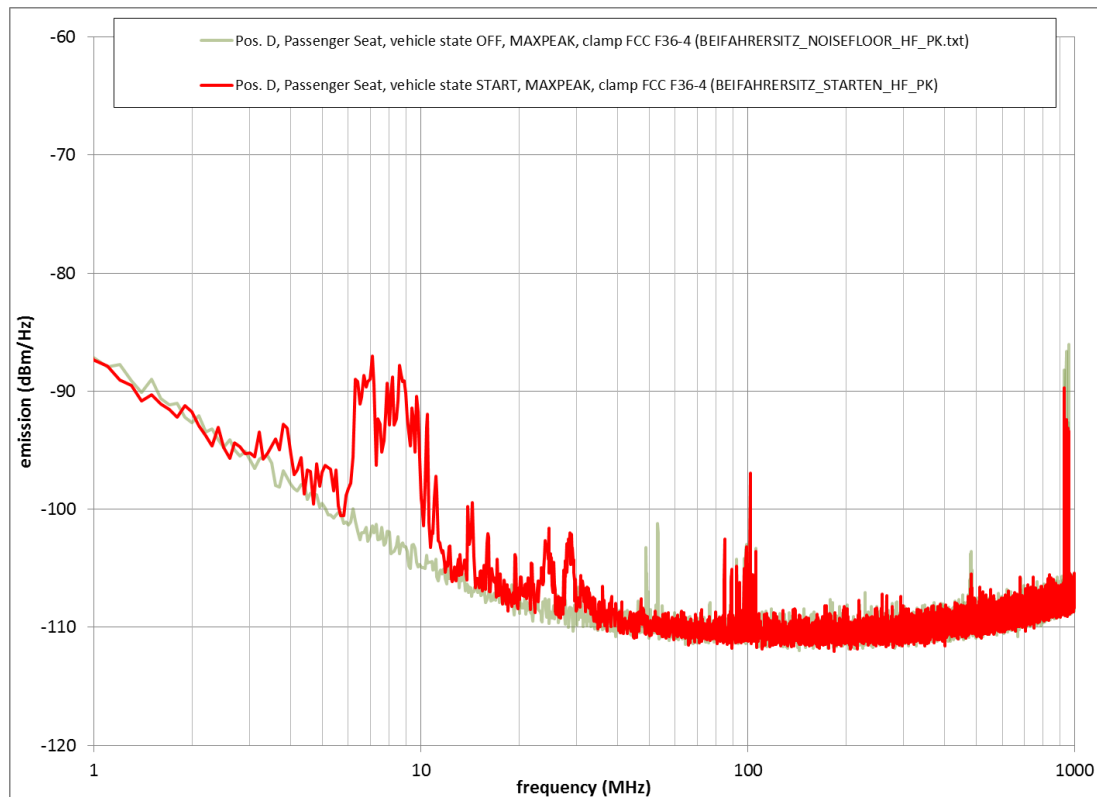

parameter	value
vehicle	MB CL500 (BB BN 378)
Spectrum analyzer settings	„HF-sweep“
Position	Passenger seat (D*)
Vehicle state	OFF and START

\*) „D“ in the CL is quite the same location as „A“ in the S-class

emission on CAN data line on all positions (driver's seat, passenger seat, trunk) and on a GND wire in trunk.

# conclusion

- most noise can be seen between DC and about 100MHz, above only coupling of GSM signals is visible.
- the overall level of the common mode noise in this measurements is a broadband noise with roughly -80dBm/Hz in the range up to 10MHz and spikes with a lower intensity (roughly -95dBm/Hz) in the higher frequency (10MHz to 100MHz). The differential mode noise on the receiver has to be derived from mode conversion parameters of the vehicle harness
- the most critical state is engine start or engine running – as expected.
- influence of potential external disturbers cannot be shown with these measurements. This external disturbers like radio stations, radar stations, mobile devices within the car (see GSM peaks in the measured spectra) cannot be derived clearly by single measurements. From OEM experience these disturbers are covered by BCI tests (see appendix A)

# appendix A (BCI test levels @ Daimler)

BCI test levels for cars  
(max 106dB $\mu$ A)

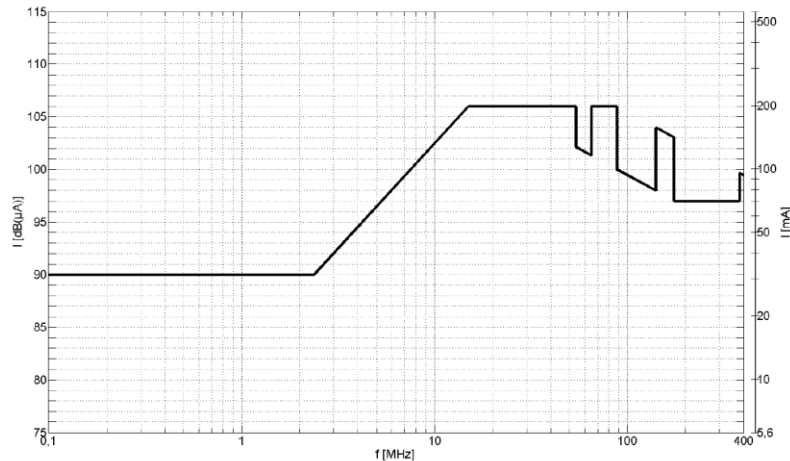

BCI test levels for trucks and busses  
(max 114dB $\mu$ A)

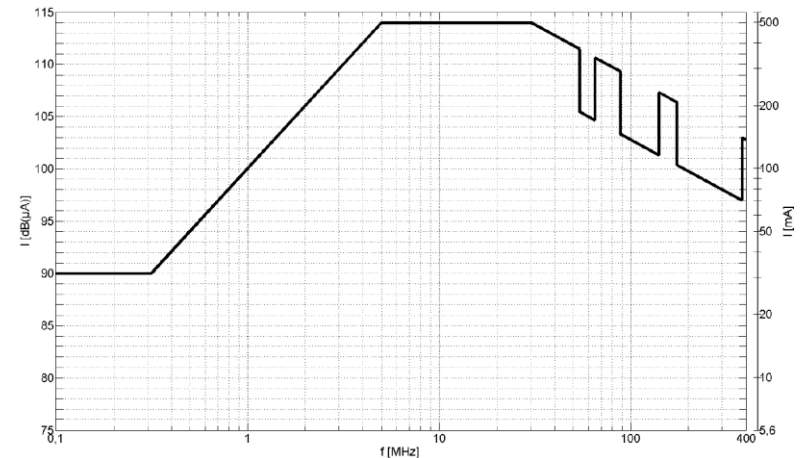

- BCI test levels in dB $\mu$ A over frequency (common mode current) for Daimler (left=cars; right=trucks and busses). This is always the maximum of a single CW or 80%AM modulated signal, not a broadband noise

# appendix A (BCI test levels @ Daimler)

Using above shown formulas and the known impedance of the BCI test setup (~300 ohms) the PSD of the common mode signal of the BCI test can be shown in dBm/Hz.

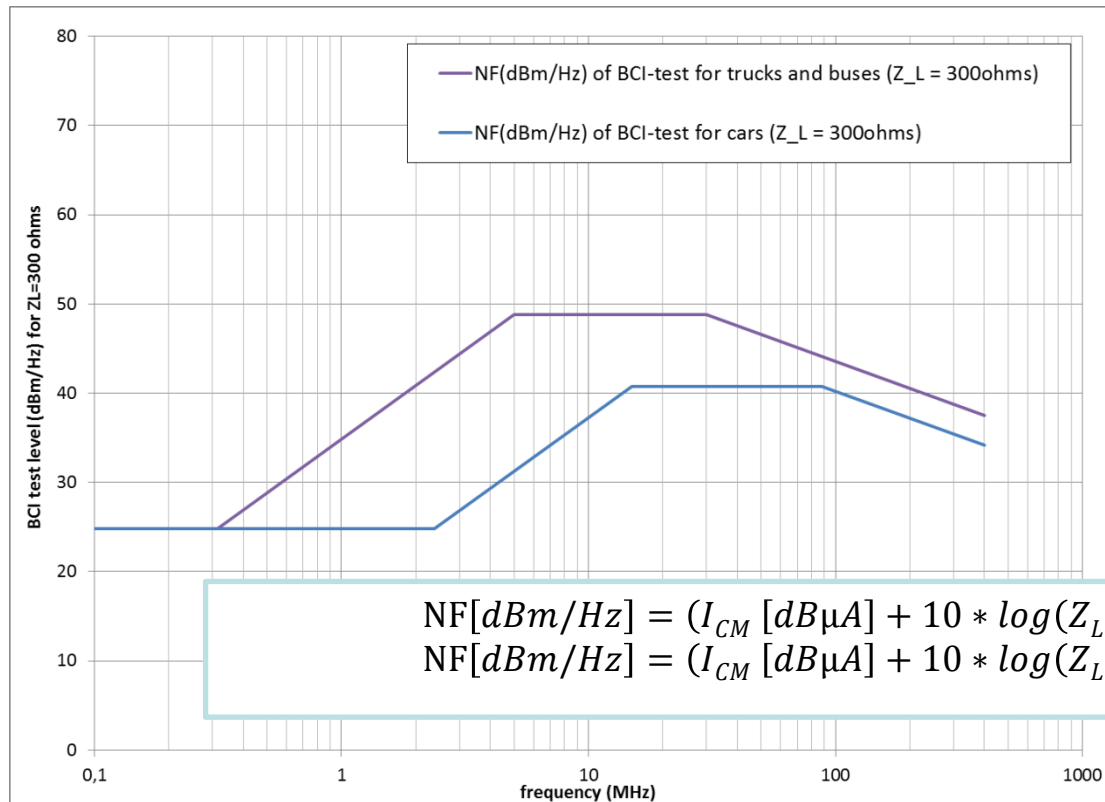

Remark: This is not a broadband disturber, but the maximum peak value of a CW or 80%AM signal

$$NF[dBm/Hz] = (I_{CM} [dB\mu A] + 10 * \log(Z_L) - 90dB) - 10 * \log(RBW)$$
$$NF[dBm/Hz] = (I_{CM} [dB\mu A] + 10 * \log(Z_L) - 90dB) - 10 * \log(1)$$

BCI level in dBm/Hz

# appendix B: calibration of current clamp

## 1. Calibration measurement of current clamp and measurement cable in 50ohm jig.

1. Type and Length of measurement cable.
2. Type and frequency range of current clamp, use different clamps to cover the complete frequency range if necessary. E.g.
  - **FCC F-36-4, 30MHz - 1GHz**
  - FCC F-2000, 100MHz - 3GHz
  - FCC F-16A, 100kHz – 60MHz
  - **Solar 9108-1N, 10kHz - 400MHz**
  - Solar 9120-1N, 10MHz - 600MHz
3. Calibration measurement ( $C = s_{31}$  or  $s_{21}$ ) according to picture/setup on the right (including the cable!).

→ Keep in mind that number of Points should be the same for calibration measurement (VNWA) and emission measurement (Spectrum analyzer)

Calibration Setup (add cable!)

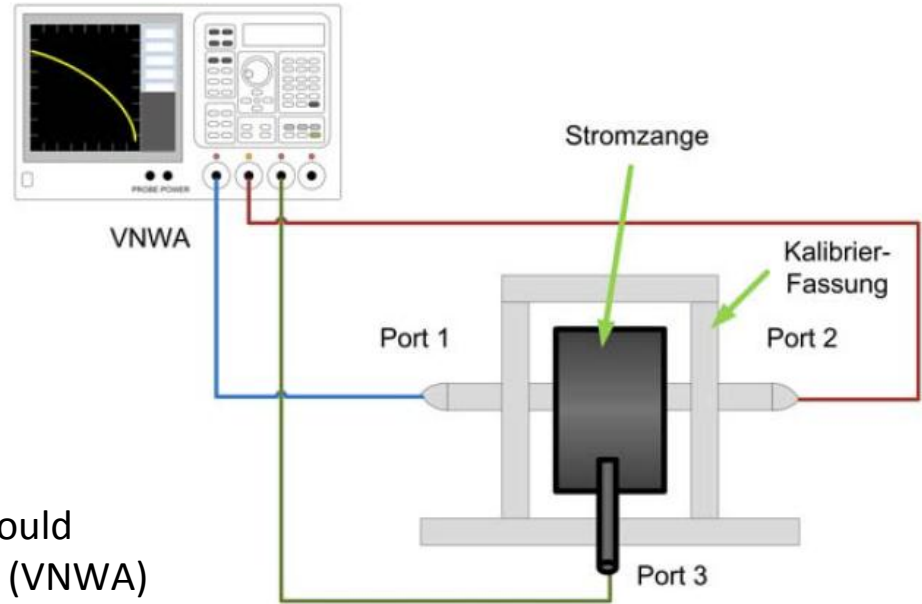

Current Clamp



# appendix C: notes/comments to measurements

- It is necessary to have same frequency points at clamp and cable measurement (calibration) and at emission measurement sweep to make it easy to subtract the clamp + cable transmission from the result (otherwise interpolation is necessary)
- RBW of 100kHz and 10.001 Points ensures that complete spectra is covered (stepsize of 100kHz).
- Alternatively for Low frequency LF the settings of RBW=10kHz and 10.001 points allow a sweep from DC to 100MHz.
- Sweep time should be set to a reasonable fast sweep, allowing multiple sweeps to be taken (with maxHold function) to enable measurements of multiple engine starts.