

EEE Update for 1000BASE-T1

San Antonio, TX, USA

November 4, 2014

Jim Graba

jgraba@broadcom.com

Contributors

- Steven Chen
- Ahmad Chini
- Peiqing Wang
- Mike Tu
- Mehmet Tazebay

Summary

- Reconciled EEE
 - Parameters
 - Exit LPI
- Refreshes
 - Consists of scrambled zeroes
 - Scrambler position
 - OAM
- 1 second delay before entry into LPI after linkup
- Refresh monitor

EEE Parameter Reconciliation

Symbol	Definition	Value
RS3	# PAM3 symbols per RS frame	2700
RST	Duration of RS frame (ns)	3600
PRS3	# PAM3 symbols per partial RS frame	180
PRST	Duration of partial RS frame (ns)	240
PF	# partial frames per RS frame	15
QRF	# RS frame per Quiet Refresh cycle	24
QRT	Duration of quiet refresh cycle (ns)	86400
AF	# partial RS frames separating alert	30
AlertGranularityT	Alert Granularity (ns)	7200
Refresh_LPI	# partial RS frames for refresh	6
Refresh_T	Duration for refresh (ns)	1440
QR_Ratio	Quiet/Refresh Ratio	60
Enter_LPI_RS	# RS frames with all LPI to enter LPI	1
Alert	Alert length (RS frames)	0.9
Exit_LPI_RS	# RS frames with all idles upon exit LPI	1

Refreshes (macro view)

- Scramble zeroes except OAM
- Scrambler after RS (tu_3bp_01_1114.pdf)

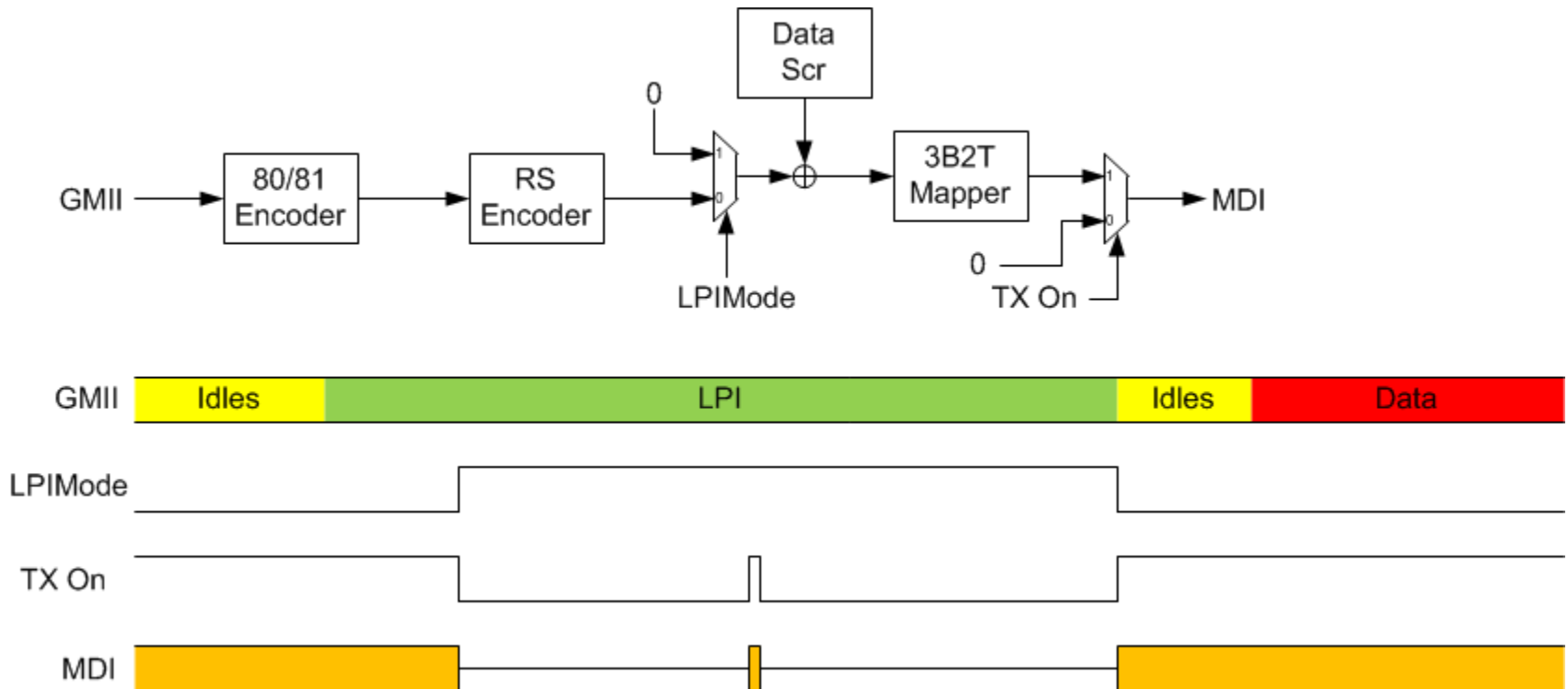

OAM During Refreshes

- Normal mode OAM
- LPI mode OAM
- Embed OAM in Refresh

Delay after linkup before LPI

- Delay 1 second between link status == OK and entry into LPI
- 78.1.2.1.2
- Does existing verbiage in 78.1.2.1.2 cover 1000BASE-T1?

Refresh Monitor

- Need to deal with unreliable Refresh detection?
 - **55.4.2.7 Refresh Monitor function:** Force a re-link if Refresh is unreliably detected after 50 Q/R cycles => 4.32ms
- Unreliable Refresh detection causes
 - Can be caused by unplugging the cable
 - Not in automotive Ethernet
 - In asymmetric LPI mode the LP receiving Normal may need to re-link
 - Instead of immediately ceasing transmission the LP can initiate a Wake and then cease transmission
 - EMI overwhelms Refresh
 - Could cause the loops to degrade
 - Alert wouldn't be recognized even after EMI is over
 - Would not want to wait until missing Alert before re-linking
- Recommend 10G type EEE Refresh Monitor