

400GbE DMT Tolerance to MPI

Toshiki Tanaka, Tomoo Takahara - Fujitsu Limited

Hideki Isono, Hisaya Sakamoto, Yuji Miyaki - Fujitsu Optical Components

- Wikipedia: **Multipath interference** (MPI) is a phenomenon in the physics of waves whereby a wave from a source travels to a detector via two or more paths and, under the right condition, the two (or more) components of the wave interfere.

- MPI(Multipath interference) degrades optical signal quality.
 - Severity of degradation depends on modulation format

- This contribution experimentally demonstrates DMT tolerance to MPI.

Experimental Setup

- 116 Gbps Discrete Multi-Tone (DMT)
- 64 GS/s DAC and ADC evaluation boards with off-line processing
- MPI emulated by interfering signal with attenuated signal copy
- Adjusted for worst case condition
 - Aligned polarization of signal with copy/crosstalk signal for maximum interference

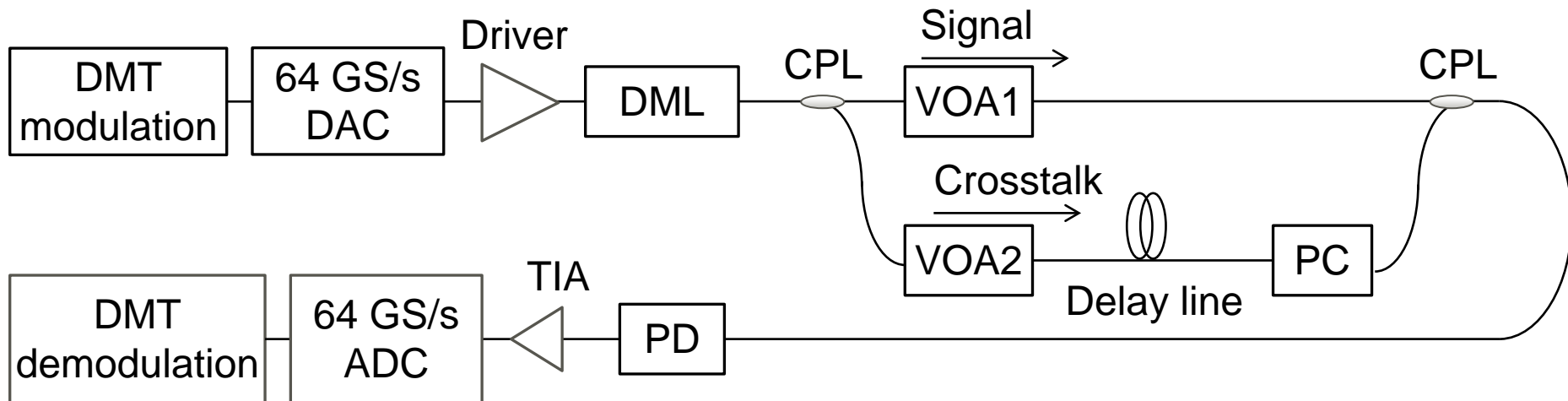

(DML: Directly modulated laser, VOA: Variable optical attenuator, CPL: Coupler, PC: Polarization controller, TIA: Trans-impedance amplifier)

■ Measured sensitivity penalty vs. cross talk

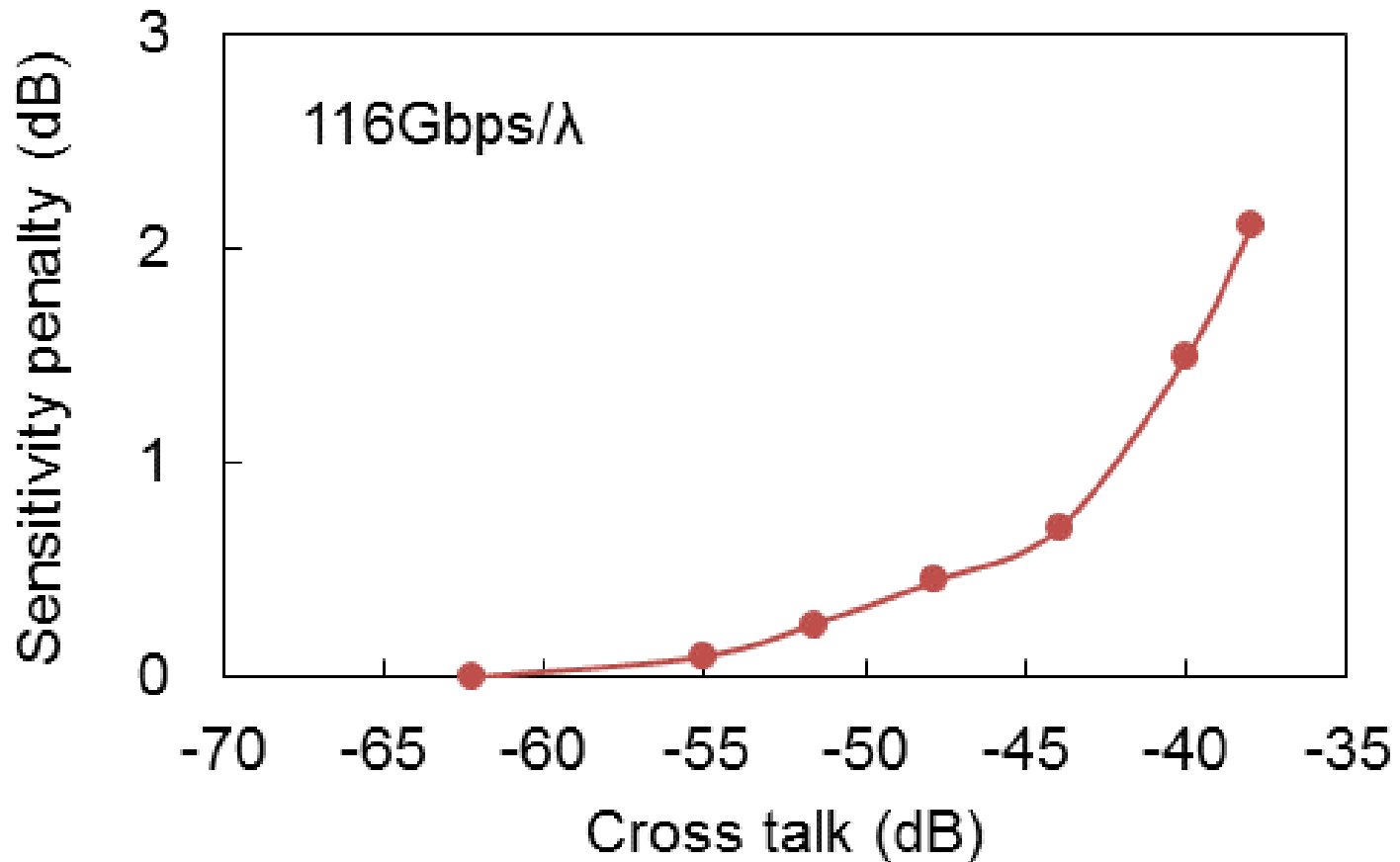

High tolerance to MPI in Optical DMT

- MPI affects low frequency components of DMT spectrum
- Only a small portion of the DMT spectrum is degraded
- DMT adjusts by adaptive bit loading of subcarriers

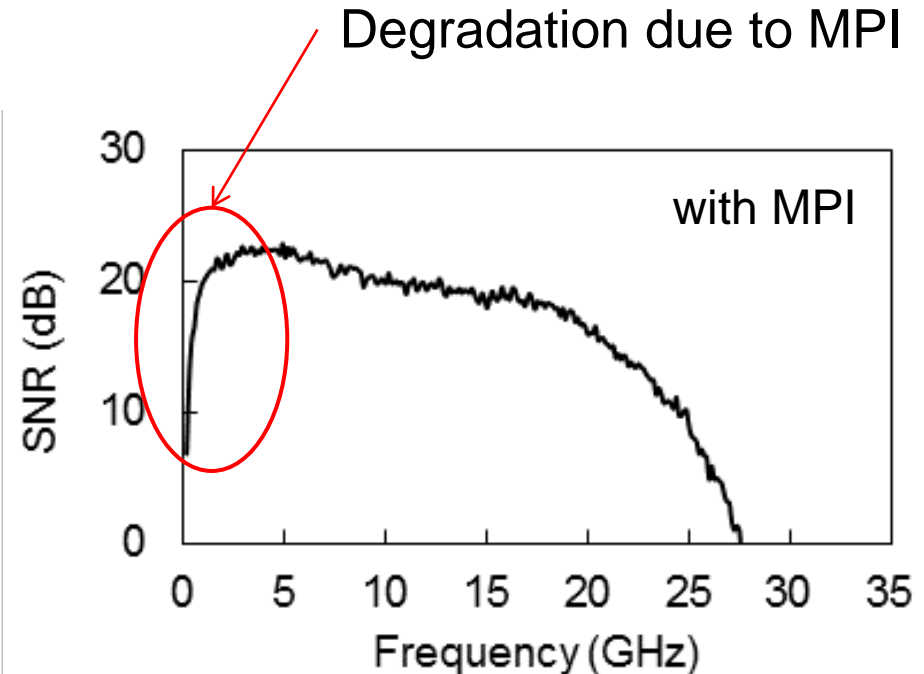
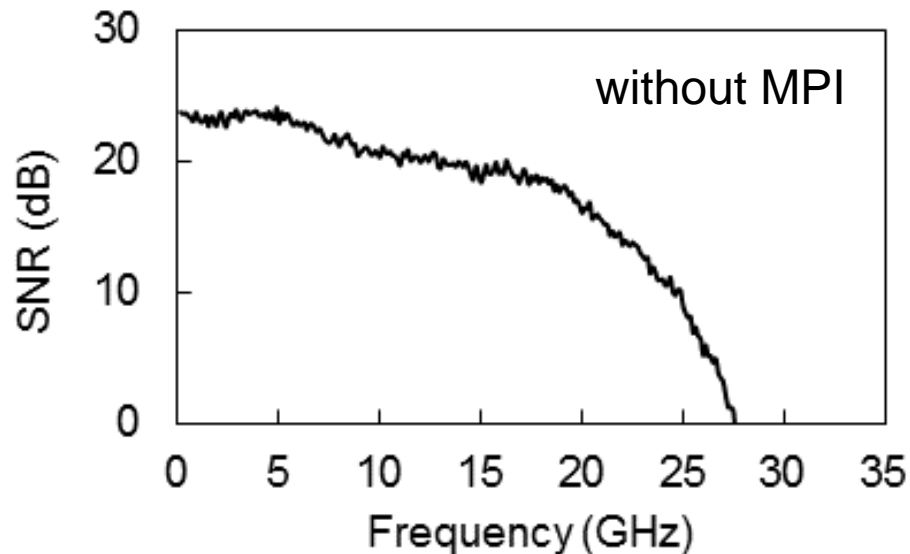

Reference Model for MPI Specification

- Reference model based on [bhatt_3bs_01a_0714.pdf](#)

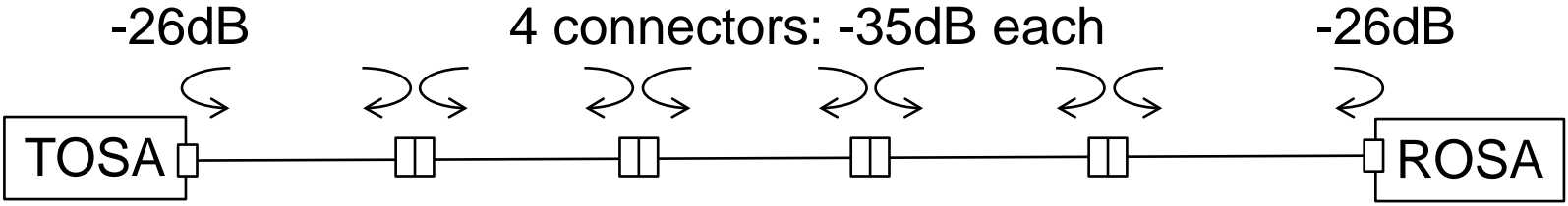

- Corresponds to -49dB crosstalk ([farhood_01_1112.pdf](#))

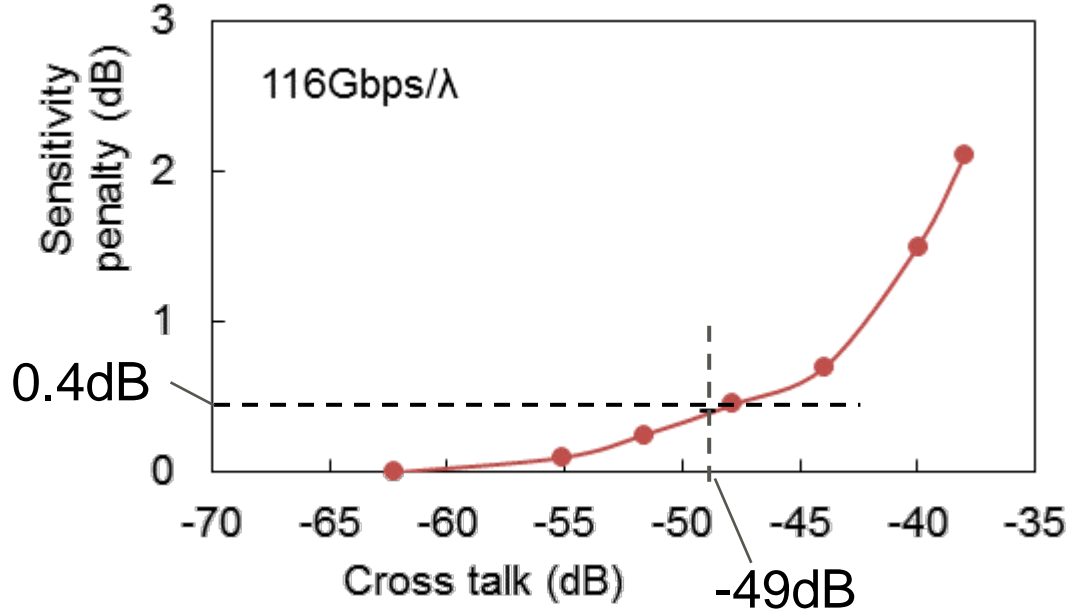

- 49dB crosstalk translates to 0.4dB sensitivity penalty

- Experiment on MPI tolerance for 400GbE DMT with 4 lamda
 - MPI only affects a small portion of the low frequency DMT spectrum
 - DMT can adjust with adaptive bit-loading

- Sensitivity penalty due to MPI (with worst case conditions)
 - Less than 0.4dB in our proposed model
 - Reflectance of TOSA=-26dB, ROSA=-26dB(common specification), and In-line connector=-35dB(bhatt_3bs_01a_0714.pdf)

Thank you