

# SSPR generation

Pete Anslow, Ciena

IEEE P802.3bs Task Force, Logic Ad Hoc, October 2016

# Introduction

The SSPRQ test pattern was added to P802.3bs D1.4 as defined in [anslow\\_01\\_0416\\_logic](#).

However, the PRBS31 generator that was used to generate the sequence in [anslow\\_01\\_0416\\_logic](#) was an different to that used by the PRBS31 generator referenced from 120.5.11.2.5, which is shown below:

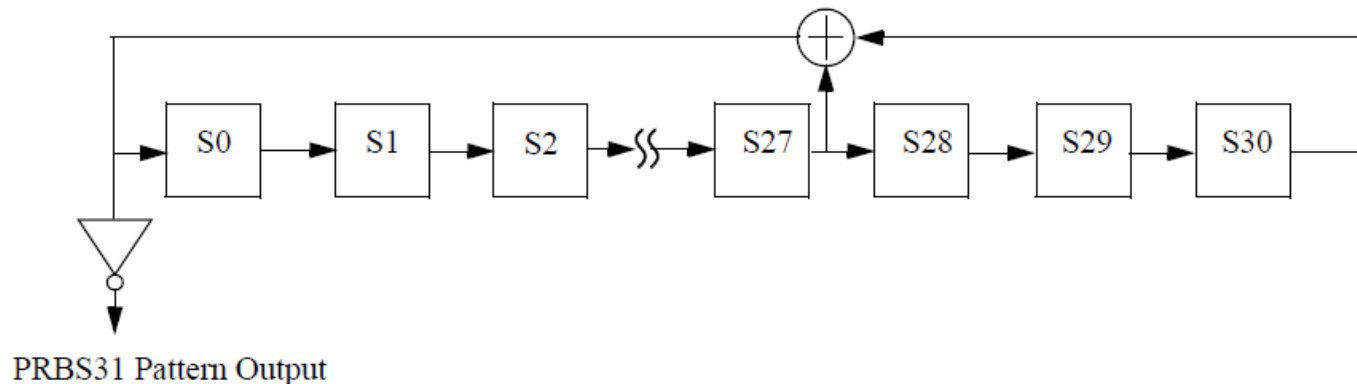

Figure 49–9—PRBS31 pattern generator

Unlike the generator used for [anslow\\_01\\_0416\\_logic](#) the above generator does not output the seed as the first 31 bits of the sequence and it has an inverter at the output.

# SSPRQ with a different generator

The consequence of using the generator from Figure 49-9 with the definition of 120.5.11.2.5 is that the resulting pattern has very different characteristics from the ones intended.

However, this can be fairly easily remedied by changing the definition in 120.5.11.2.5 so that the hex values in Table 120-2 are the seed for the generator rather than the first 31 bits of each section.

**Table 120–2—SSPRQ bit sequence A**

Pattern	Seed	Length
PRBS31	0x00000002	10924 bits
	0x34013FF7	10922 bits
	0x0CCCCCCC	10922 bits

Each section of PRBS31 is generated as if produced by the shift register implementation shown in Figure 49-9 and the seed is a 31-bit hexadecimal value used to preset S30 through S0 (S30 is set to the MSB and S0 is set to the LSB) prior to the generation of the PRBS31 sequence for the indicated length of bits.

# Baseline wander

Previous NRZ contributions have used a “baseline wander” parameter

This was defined as:

Baseline wander is the instantaneous offset (in %) in the signal generated by AC-coupling at the Baud rate / 10,000.

This analysis re-uses this definition unmodified, but it should be noted that for PAM4, the eye height is 1/3 that of NRZ so the effects of a given amount of baseline wander will be greater. Because of this plots have also been done at a more realistic **Baud / 50,000**.

# Clock content

The “clock content” parameter is defined here as:

Create a function which is a 1 for a transition and a 0 for no transition and then filter the resulting sequence with a corner frequency of  $\text{Baud}/6641$  (or  $\text{Baud}/13281$ ).

This analysis defines a transition as one of three possibilities (as per [healey\\_3bs\\_01\\_1115](#)):

- Symmetrical transitions through the signal average
- Transitions through the signal average
- All transitions

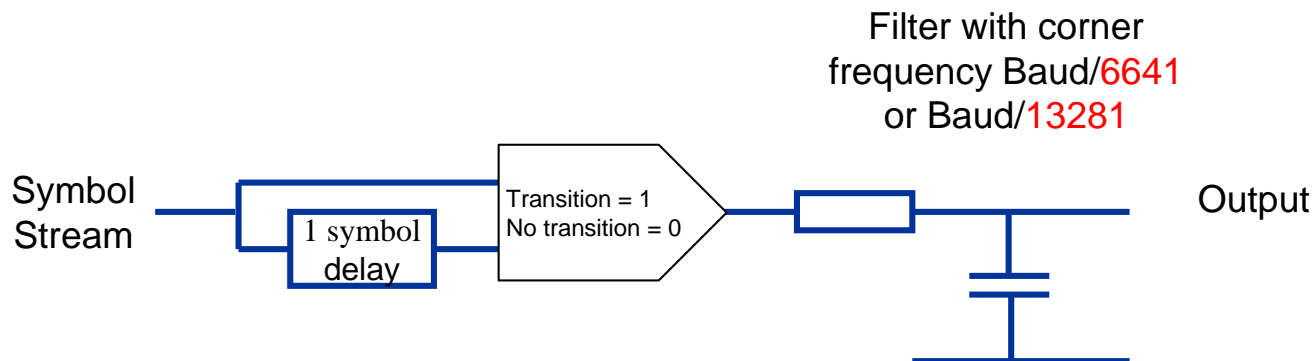

# Clock content illustration

Symmetrical  
transitions  
through the  
signal average

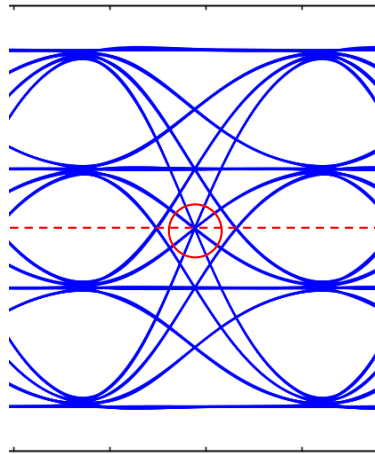

Transitions  
through the  
signal average

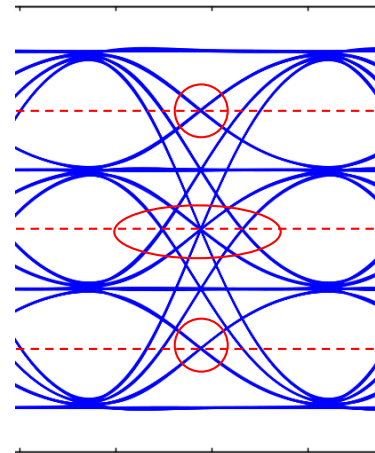
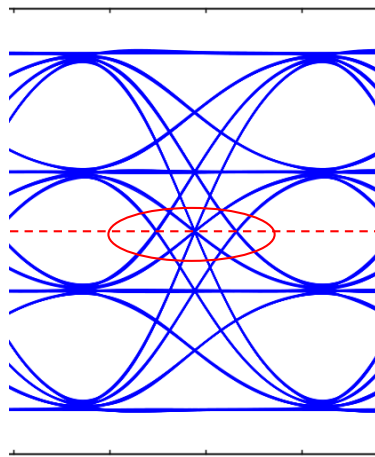

All transitions

# PRBS13Q and PRBS31Q

The following slides contain the baseline wander and three clock content probability density plots for:

- Random data (solid green)
- Fit to random data (dotted green)
- PRBS13Q (blue)
- PRBS31Q (red)
- SSPRQ (purple)

Note: **previous** on the following slides refers to previous presentation ([anslow\\_01\\_0416\\_logic](#)) rather than what the SSPRQ characteristics are as defined in D2.1.

# Baseline wander (Baud / 10,000) **previous**

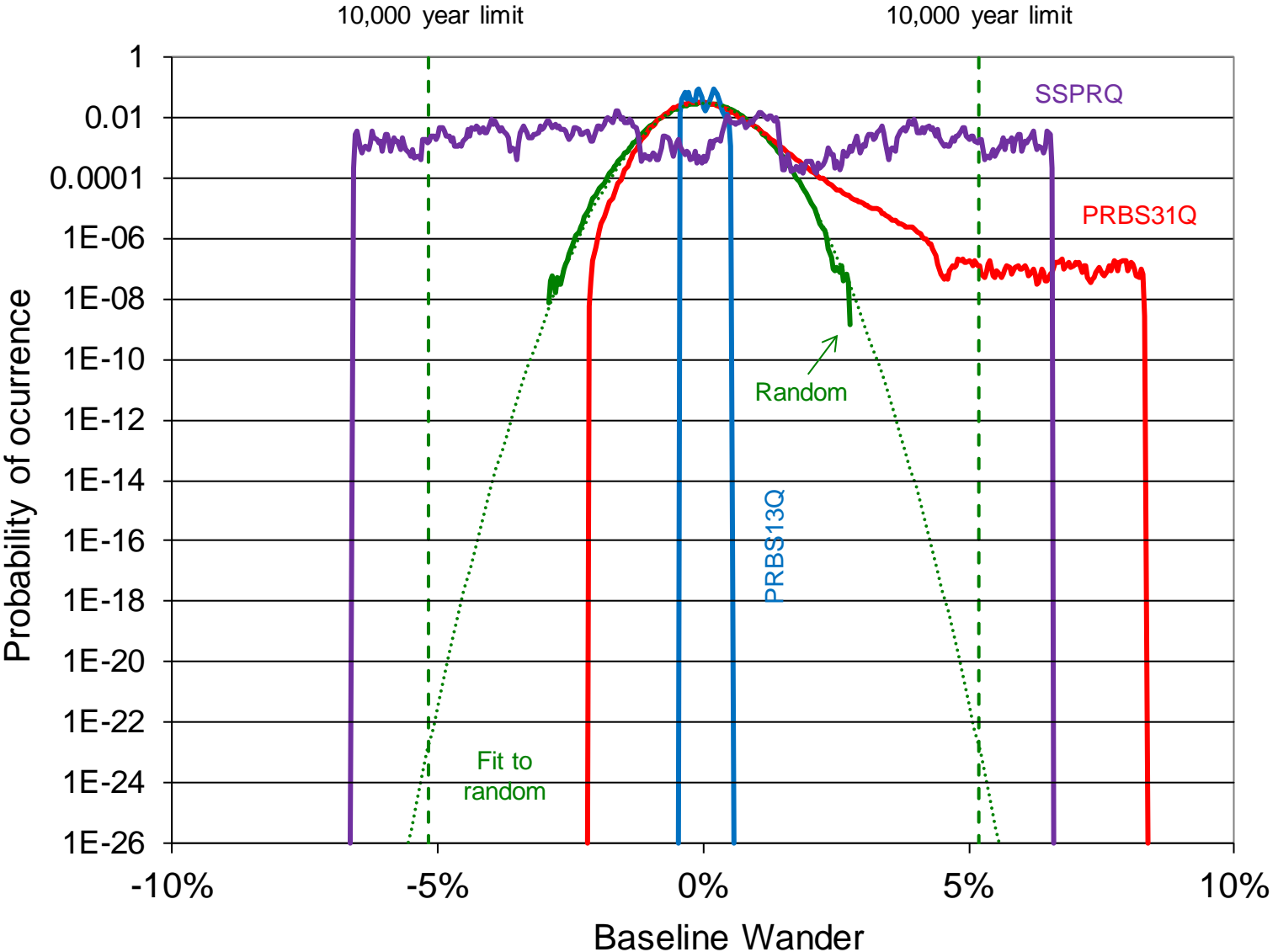



# Baseline wander (Baud / 10,000) **new**

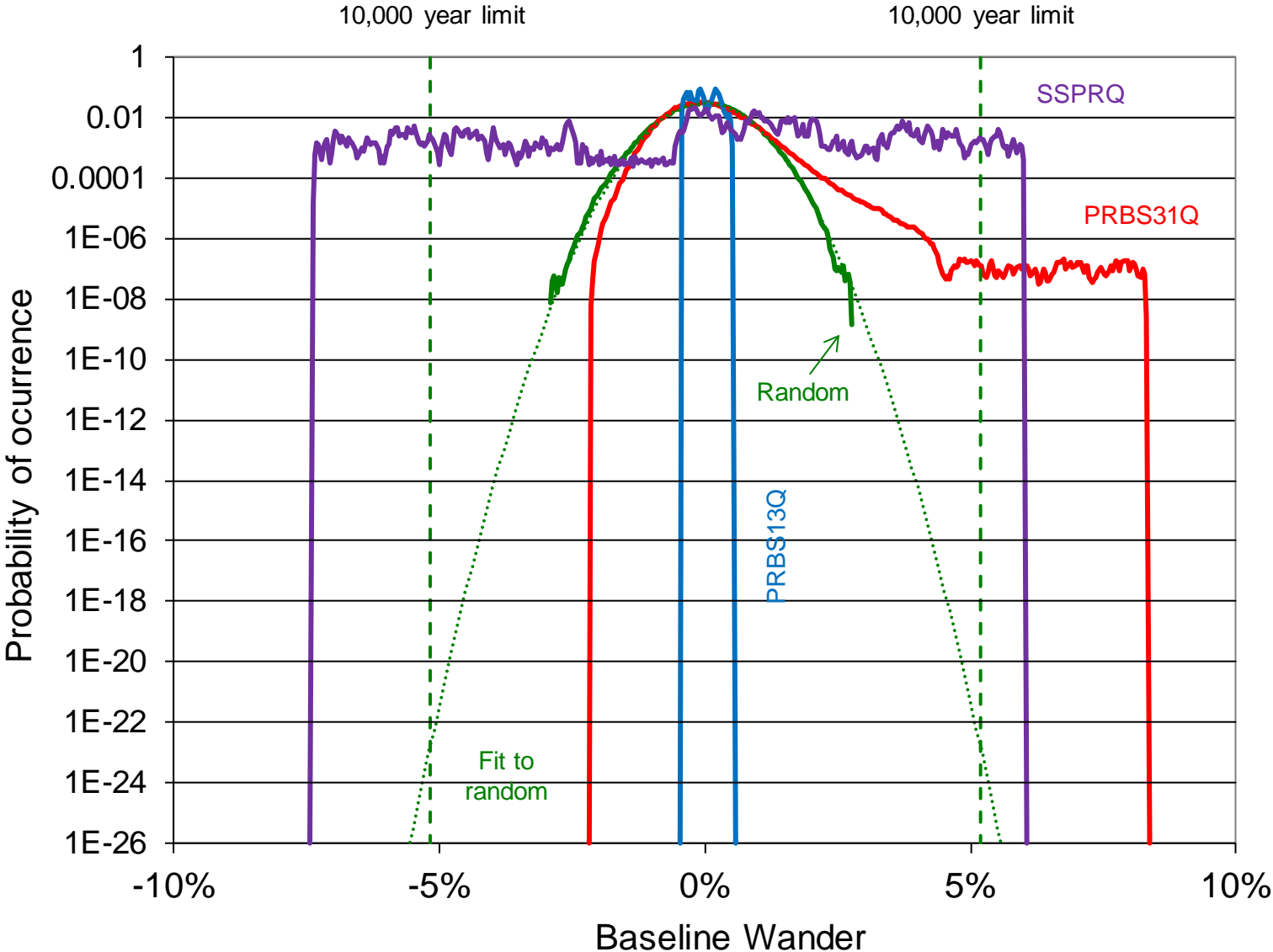

# Baseline wander (Baud / 50,000) **previous**

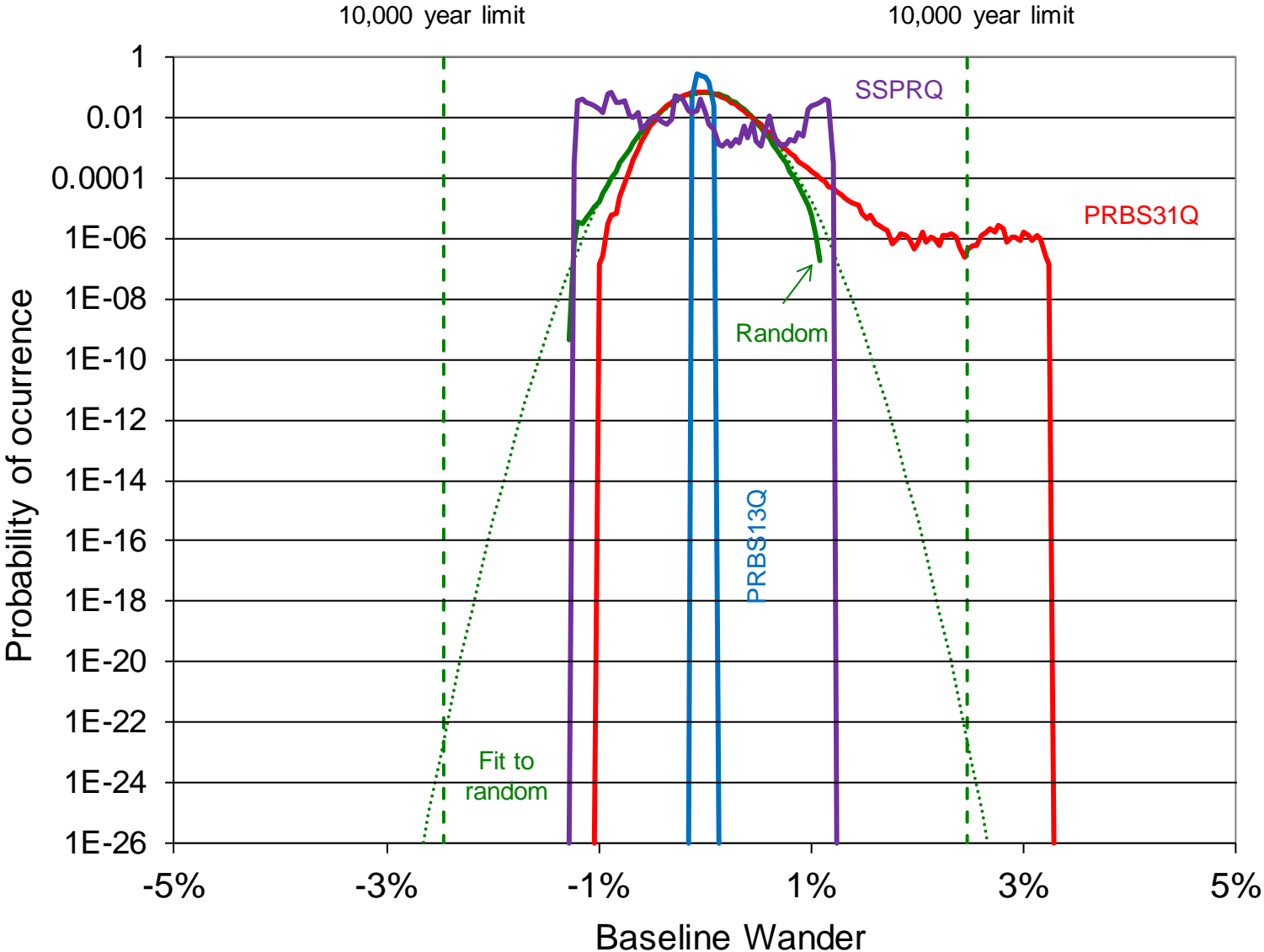

# Baseline wander (Baud / 50,000) **new**

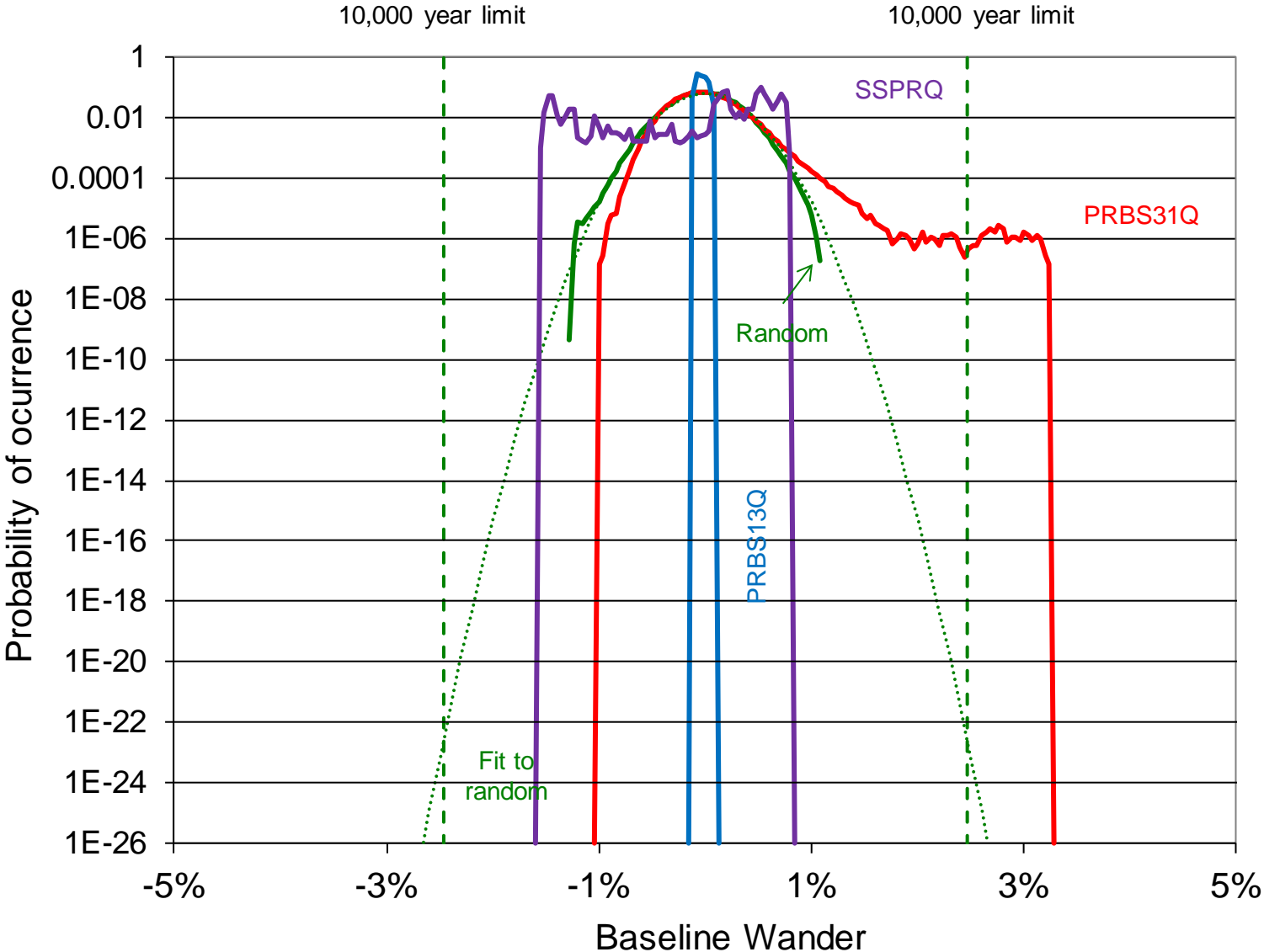

# Clock, sym. trans. thro ave, Baud/6641 **previous**

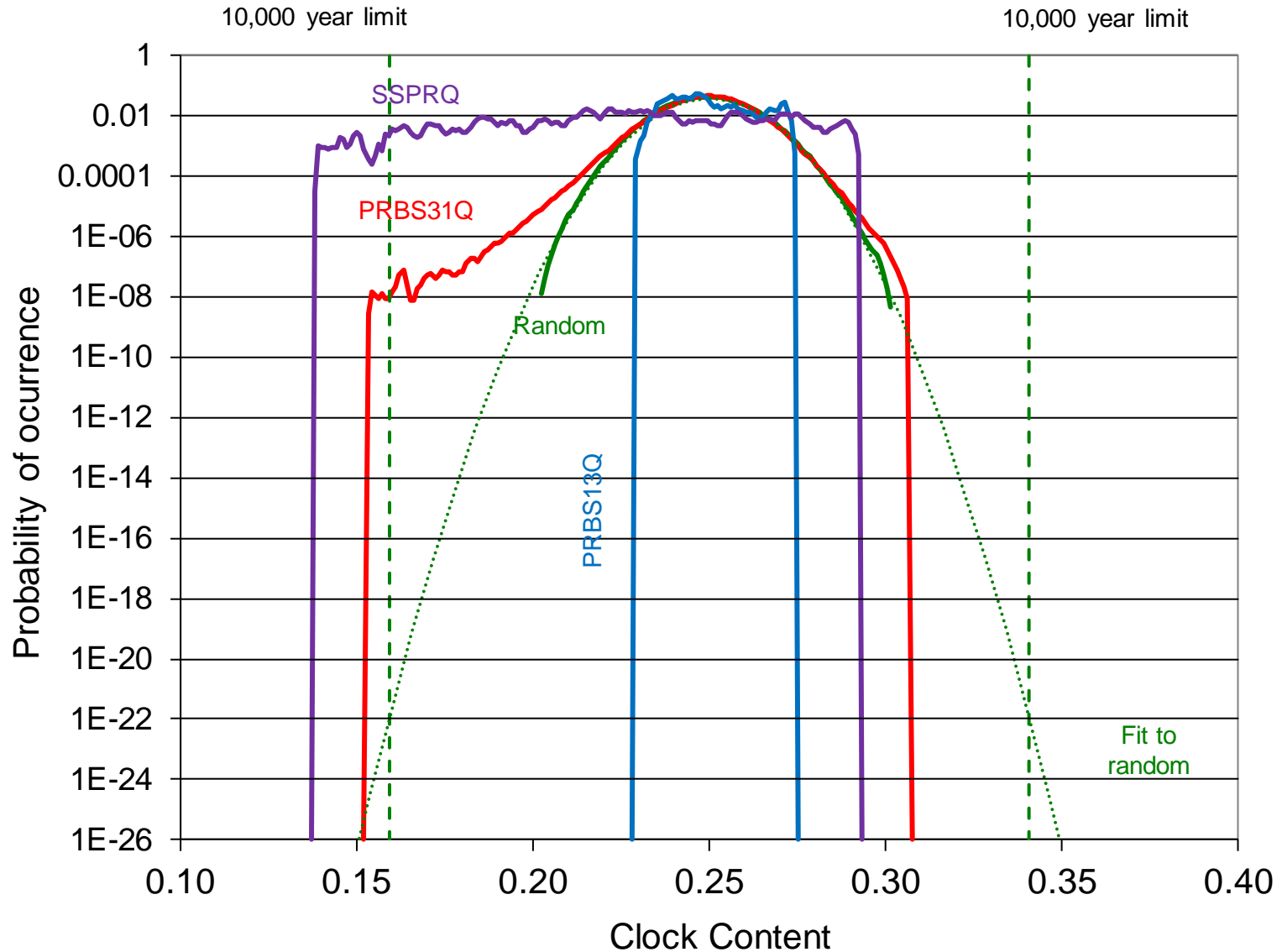

# Clock, sym. trans. thro ave, Baud/6641 **new**

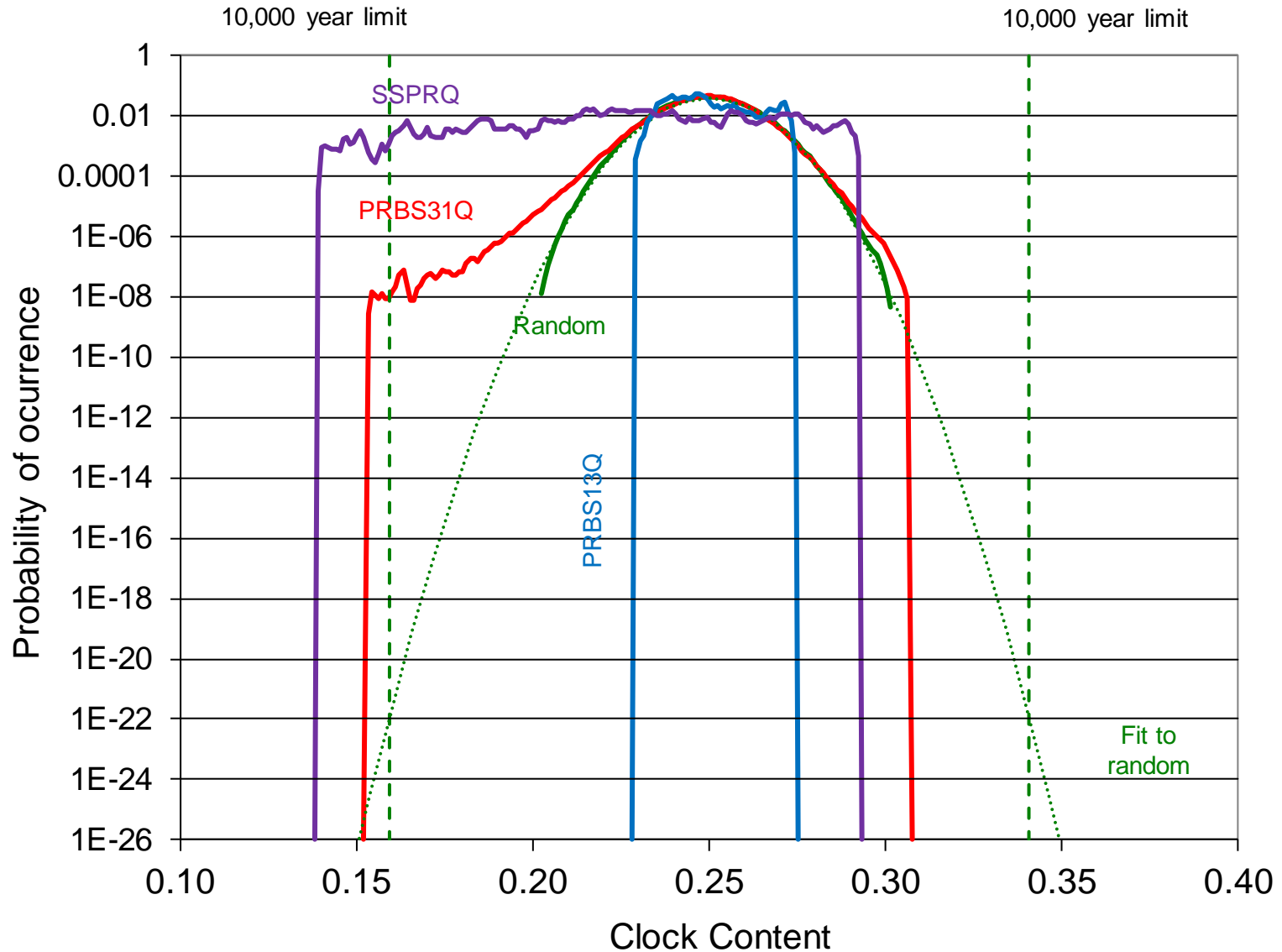

# Clock, trans. through ave, Baud/6641 **previous**

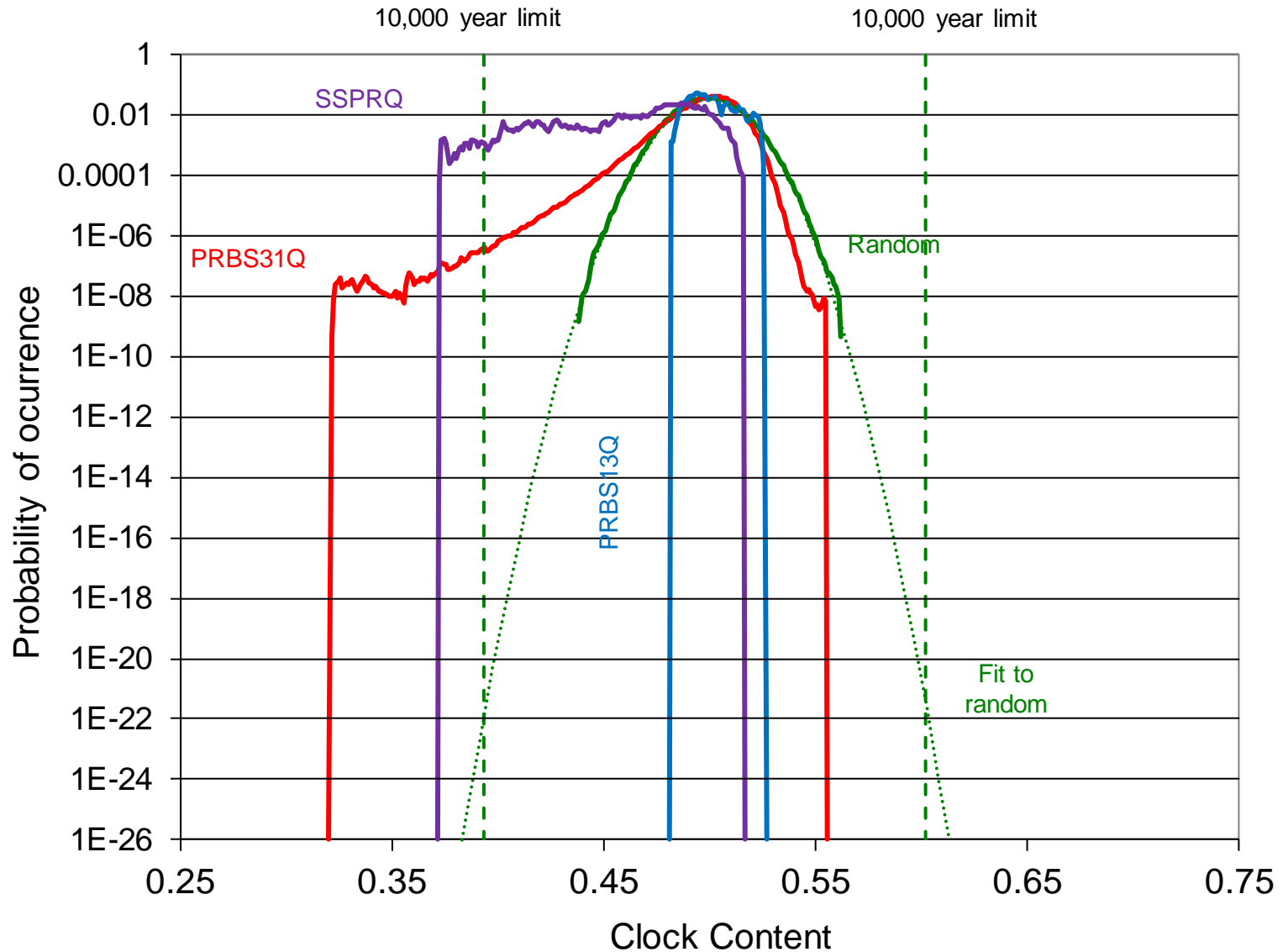

# Clock, trans. through ave, Baud/6641 new

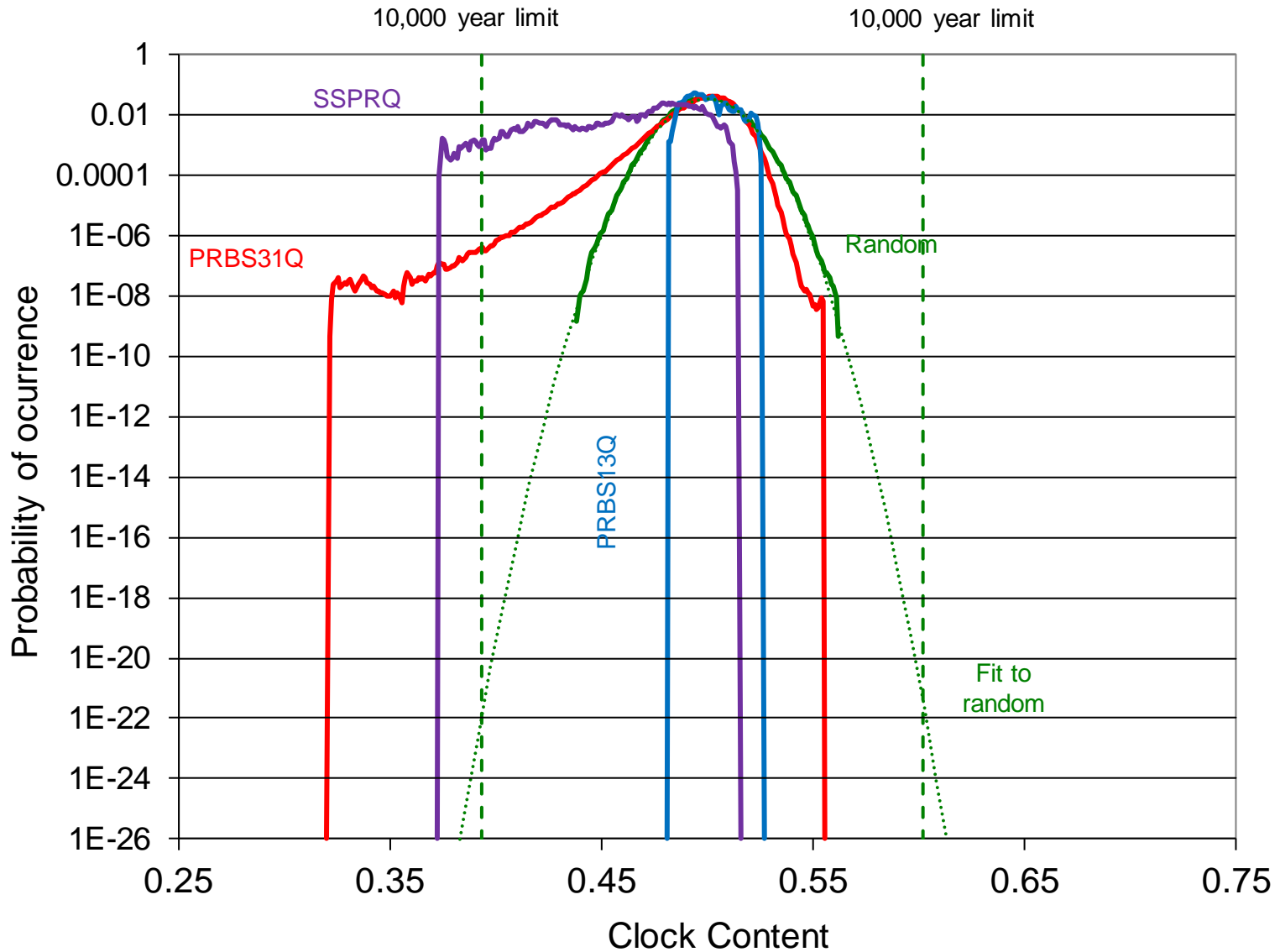

# Clock, all transitions, Baud/6641 **previous**

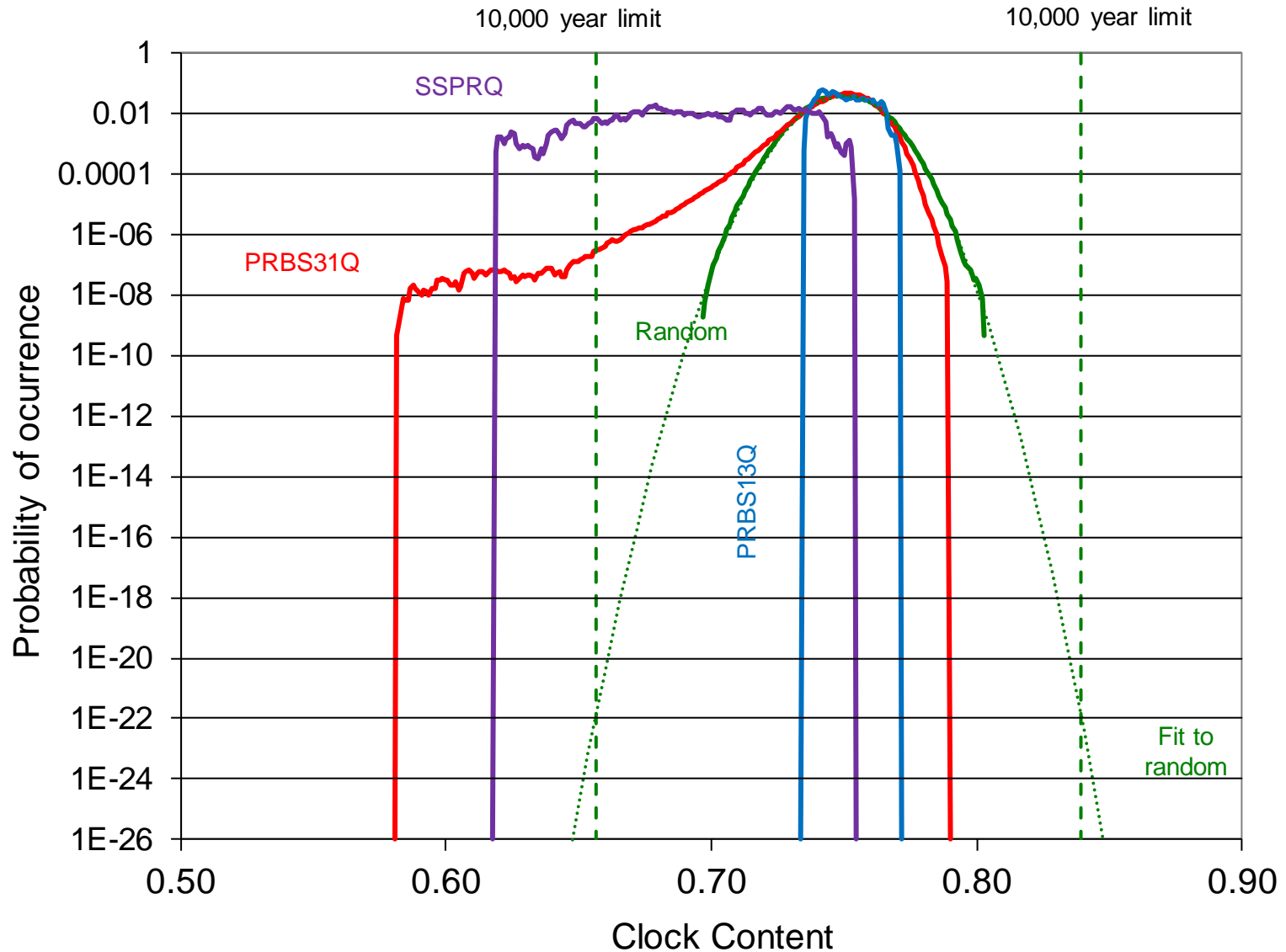



# Clock, all transitions, Baud/6641 new

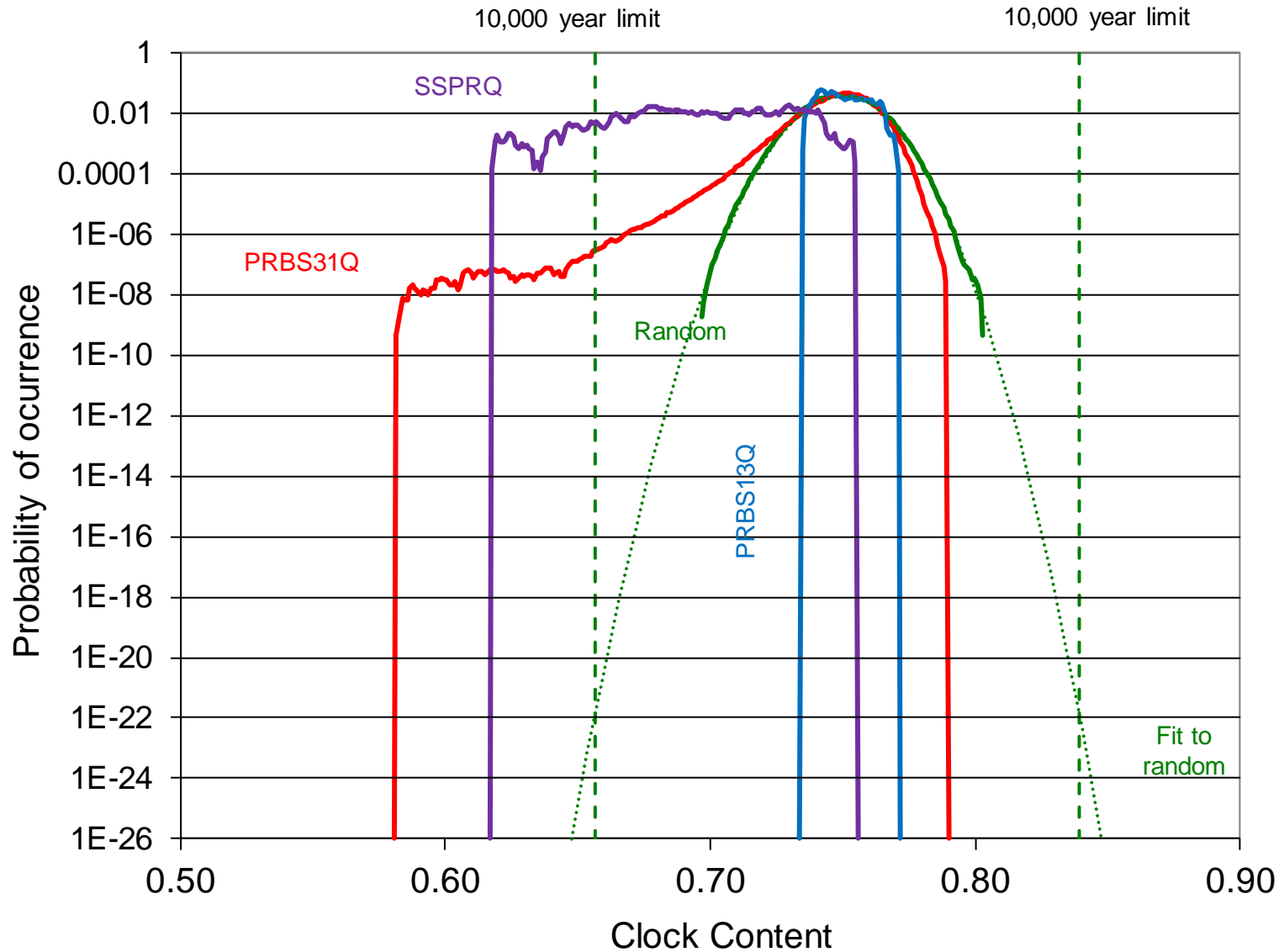

# Clock, sym. trans. thro ave, Baud/13281 **previous**

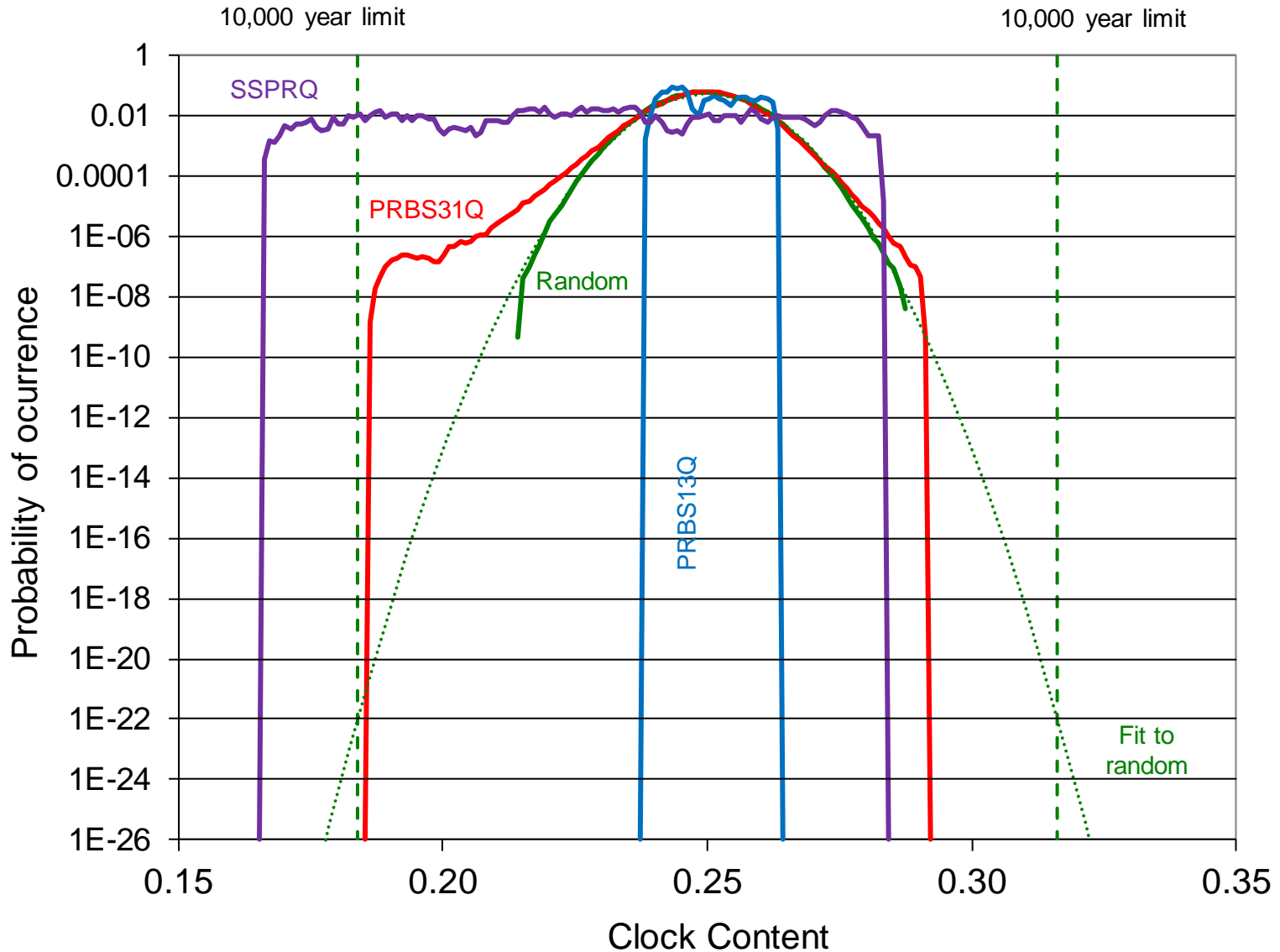

# Clock, sym. trans. thro ave, Baud/13281 **new**

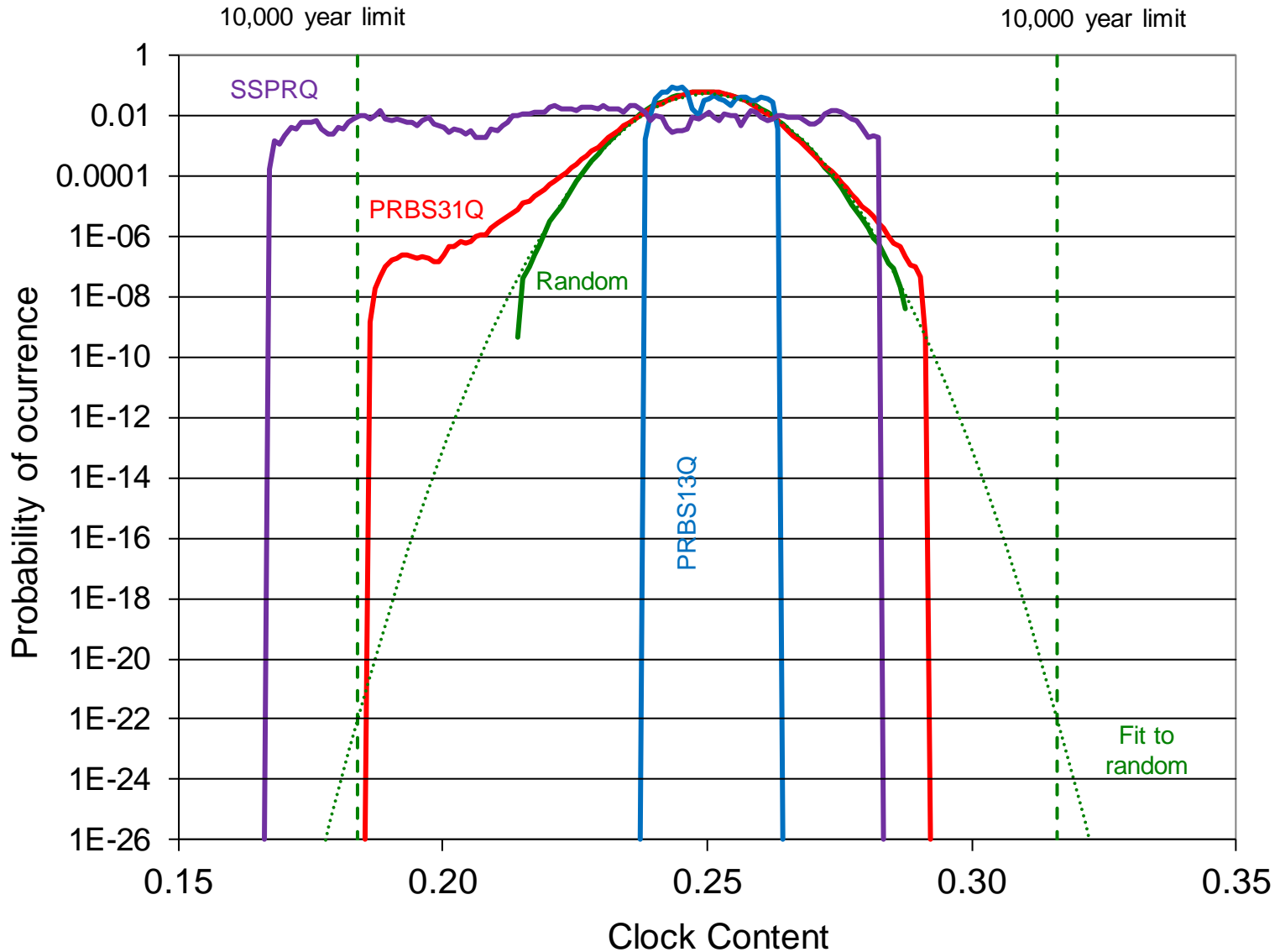

# Clock, trans. through ave, Baud/13281 previous

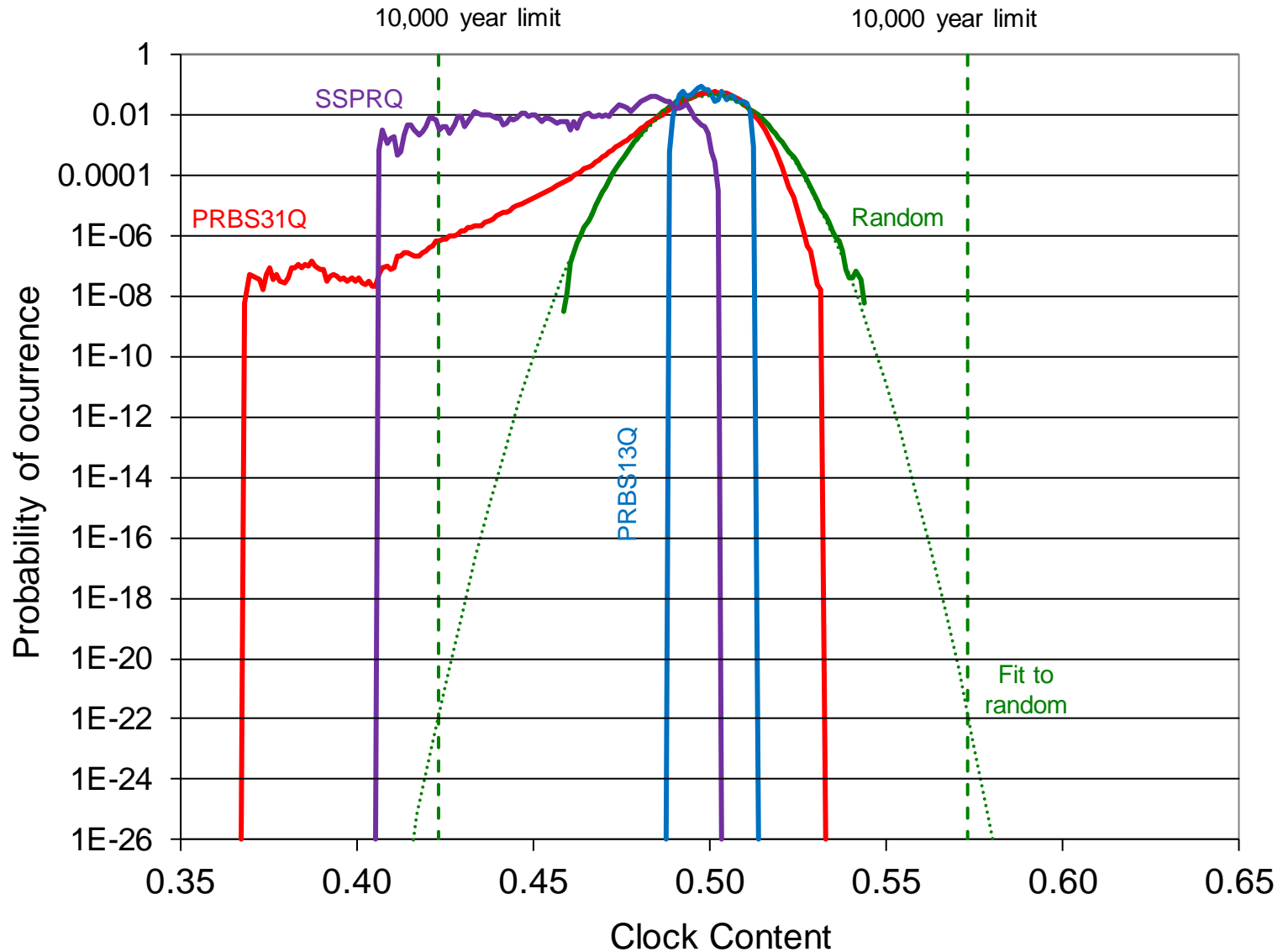

# Clock, trans. through ave, Baud/13281 new

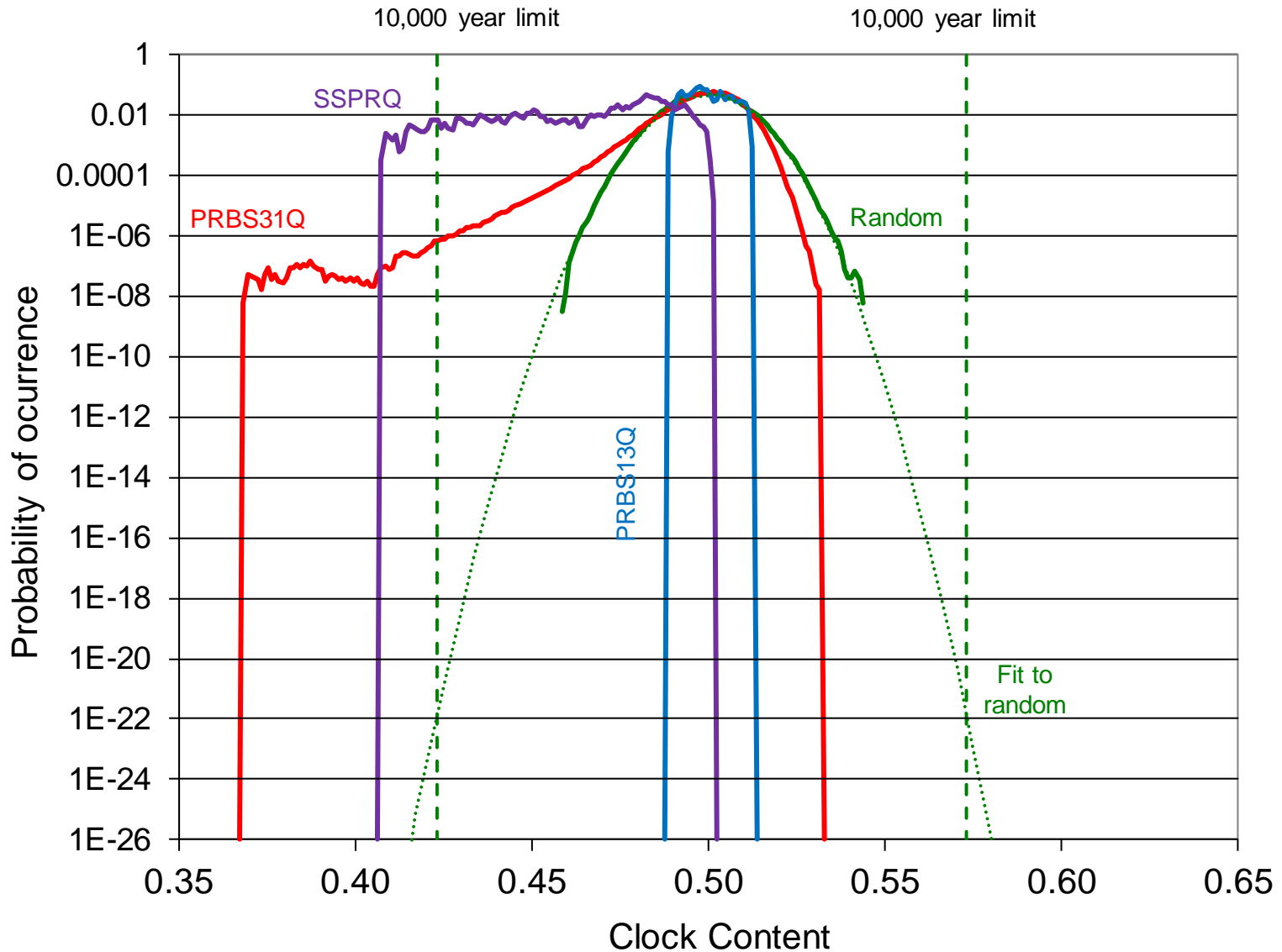

# Clock, all transitions, Baud/13281 **previous**

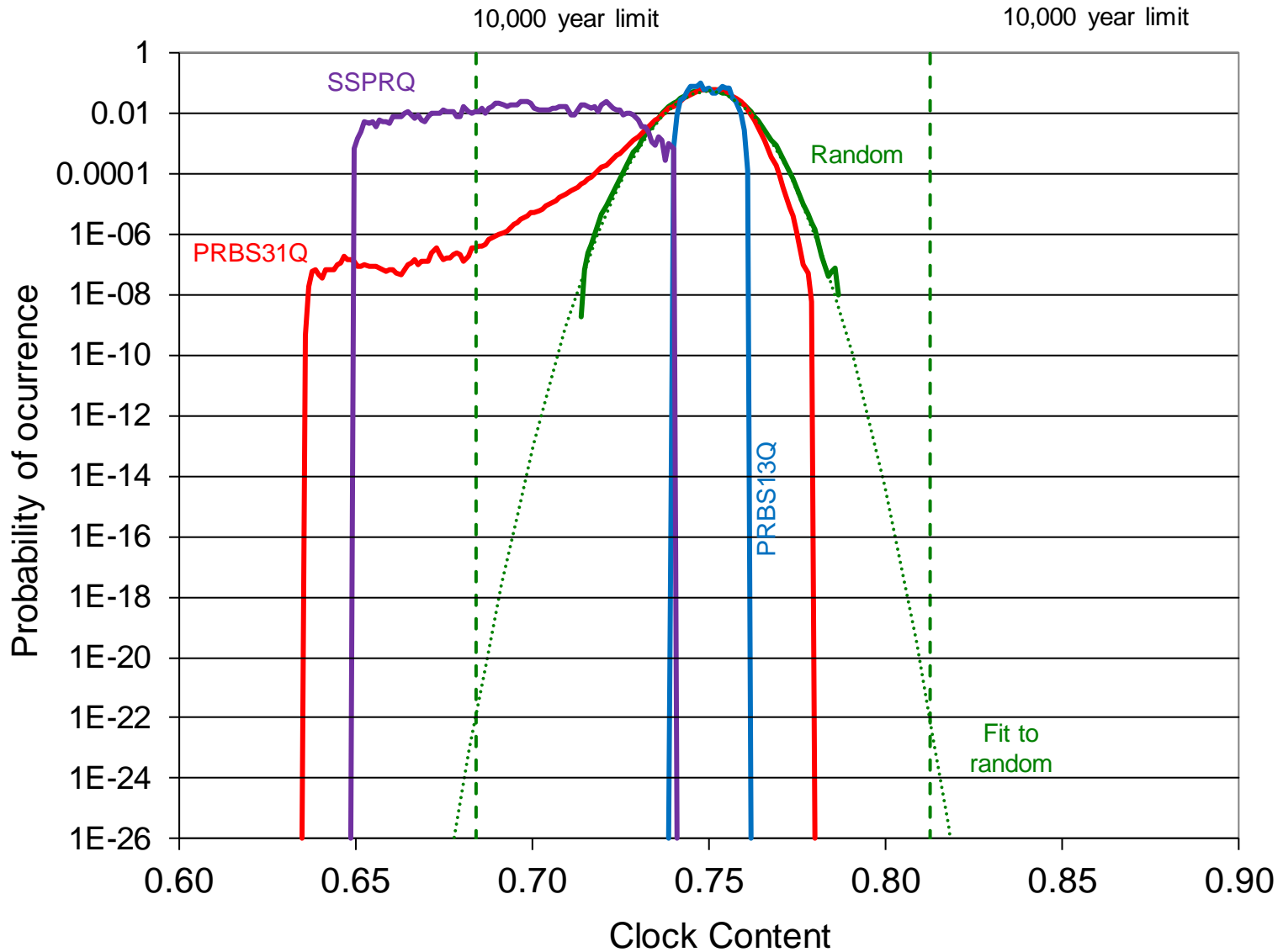

# Clock, all transitions, Baud/13281 new

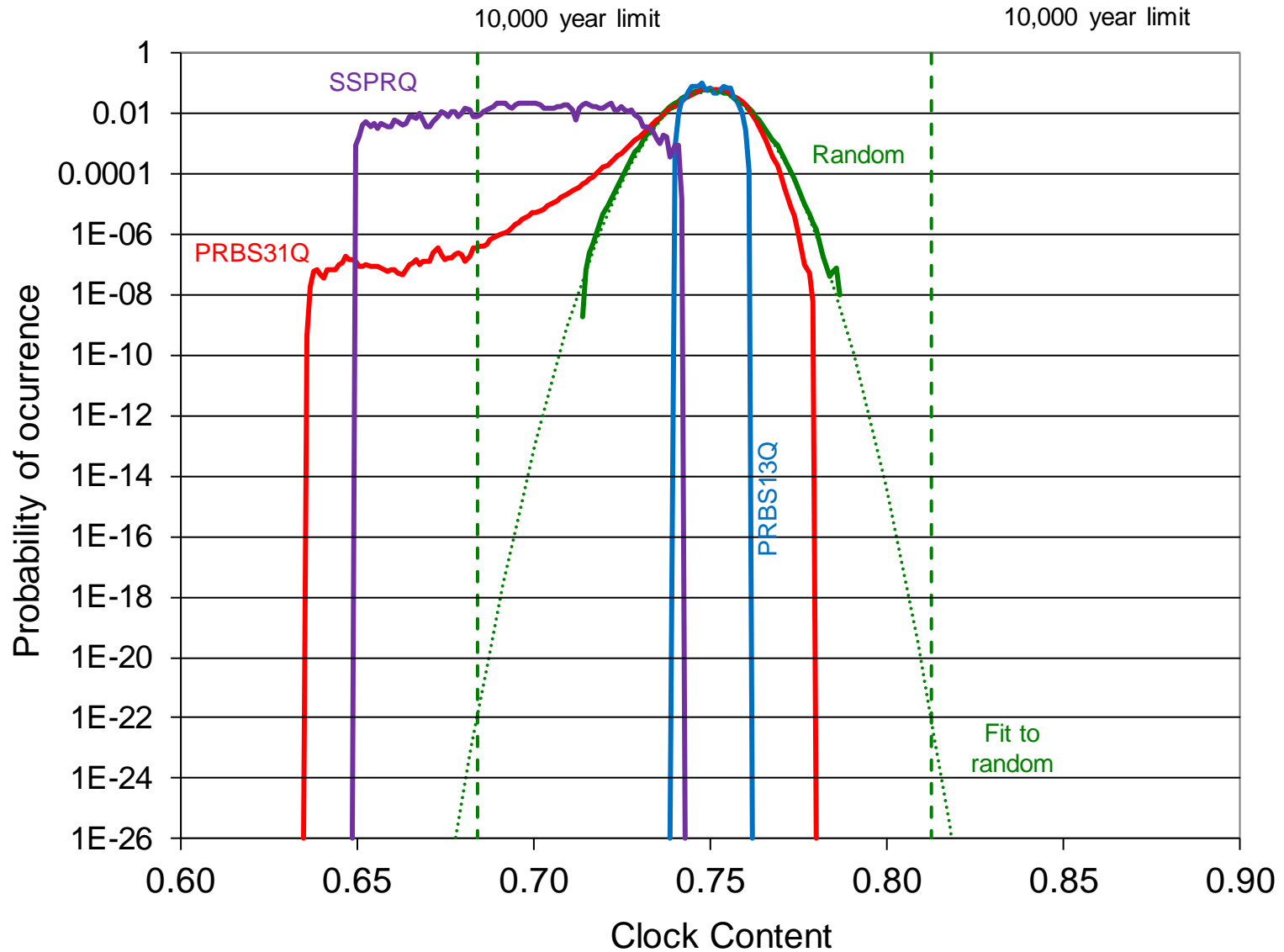

# Conclusion

The baseline wander and clock content for the revised SSPRQ pattern created using the PRBS31 generator in Figure 49-9 has very similar properties to the previous version.

It is therefore proposed to modify the SSPRQ definition in 120.5.11.2.5 as per page 3 of this contribution.



Thanks!