

Method to Estimate Max Acceptable TDEC

John Petrilla: Avago Technologies

April 2015

Presentation Outline & Conclusion

Outline:

- A method of estimating maximum value for TDEC and effect of M1 and M2 is presented.
- Tables from petrilla_01-0415_mmf are repeated to show the differences in link model attributes between 100G SR4 and 400G SR16 cases.

Link Model & Other References

http://www.ieee802.org/3/bm/public/may13/petrilla_04_0513_optx.pdf

<http://www.ieee802.org/3/bm/public/may13/ExampleMMF%20LinkModel%20%20130503.xlsx>

http://www.ieee802.org/3/bm/public/nov14/petrilla_01b_1114_optx.pdf

New Metric Offers More Accurate Estimate of Optical Transmitter's Impact on Multimode Fiber-optic Links; Greg LeCheminant, Piers Dawe, John Petrilla; DesignCon 2015; 3-WE1

What's in TDEC & SRS OMA?

Signal Power Budget Allocations Overview

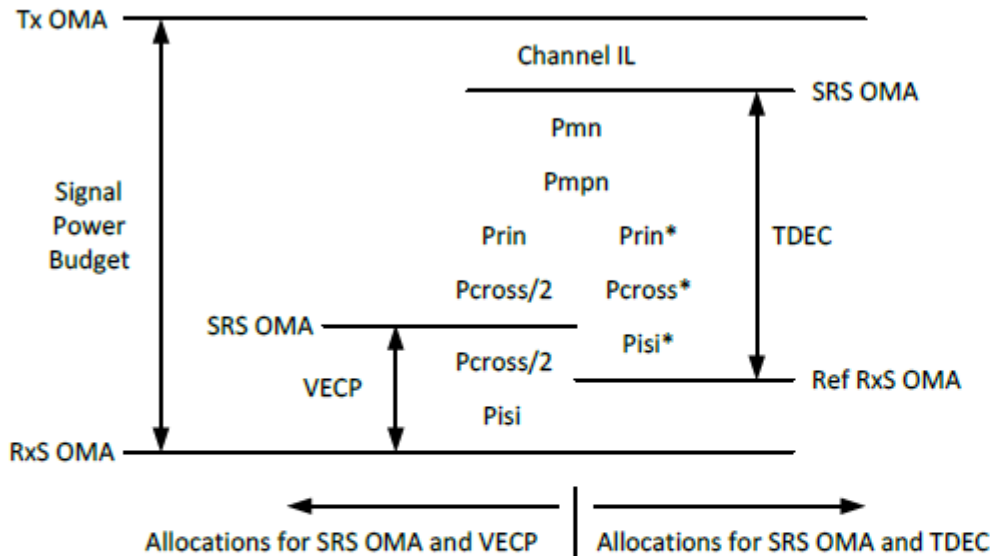

- Stressed Rx Sensitivity (SRS OMA) used to include noise penalties as well as the Channel Insertion Loss. Now it just includes the Channel Loss and all penalties are included by capture or allocation in TDEC.
- The Ref Rx used to be assumed to have the same bandwidth (BW) as the worst case Tx and little to none of the Signal Power Budget was assigned to the Rx. Now the BW can be different and some of the signal budget is given to Rx impairments.
- Penalties, $Prin^*$, $Pcross^*$ and $Pisi^*$, that depend on the Rx BW differ from $Prin$, $Pcross$ and $Pisi$ due to the difference in BW between the Ref Rx and the worst case Rx.

- With the change in method from TDP to TDEC, there's a change in some familiar terms. The above figure provides an overview of what has changed and what has not.
- The Signal Power Budget is still the difference between the worst case Tx OMA and unstressed Rx Sensitivity (RxS OMA).

• Above image comes from the presentation associated with the paper, 3-WE1, "New Metric Offers More Accurate Estimate of Optical Transmitter's Impact on Multimode Fiber-optic Links" by Greg LeCheminant, Piers Dawe and John Petrilla at DesignCon 2015.

• Since Pmn & Pmpn are not captured in the defined measurement for TDEC, they are included by allocation.

Link Model Based Method For Estimating Max Acceptable TDEC Value (1/2)

Max TDEC (100G SR4 Example Link Model Analysis)

	WC	RefRx	TDEC	Trans. time loss		RIN loss		Jitter loss		Total loss	
Reach	100	100	2	100	2	100	2	100	2	100	2
Uc	840	840	840	840	840	840	840	840	840	840	840
Uw	0.60	0.60	0.60	0.60	0.60	0.60	0.60	0.60	0.60	0.60	0.60
Transition time	21	21	21	1	1	21	21	21	21	1	1
Prin	0.74	0.59	0.58	0.17	0.16	0	0	0.27	0.27	0	0
Pmpn	0.11	0.11	0	0.11	0	0.11	0	0.09	0	0.09	0
Pmn	0.129	0.129	0.129	0.129	0.129	0.129	0.129	0.129	0.129	0.129	0.129
TP1 RJ (BER)	0.059	0.059	0.059	0.059	0.059	0.059	0.059	0	0	0	0
TP1 DJ	0.110	0.110	0.110	0.110	0.110	0.110	0.110	0	0	0	0
DCD	0.05	0.05	0.05	0.05	0.05	0.05	0.05	0	0	0	0
TP3 DJ	0.247	0.247	0.247	0.247	0.247	0.247	0.247	0	0	0	0
Rx DJ	0.049	0	0	0	0	0	0	0	0	0	0
TP4 TJ	0.780	0.780	0.780	0.780	0.780	0.780	0.780	0.780	0.780	0.780	0.780
BLW	0.025	0	0	0	0	0	0	0	0	0	0
RxBW	18.05	19.34	12.6	19.34	12.6	19.34	12.6	19.34	12.6	19.34	12.6
Signal Budget	8.20	8.20	8.20	8.20	8.20	8.20	8.20	8.20	8.20	8.20	8.20
IL	1.86	1.86	1.51	1.86	1.51	1.86	1.51	1.86	1.51	1.86	1.51
LP Pen	6.34	5.35	5.18	2.33	2.19	4.68	4.55	3.44	3.32	0.98	0.88
Margin	0.00	0.99	1.52	4.01	4.51	1.66	2.14	2.89	3.37	5.35	5.81

•The table shows comparisons of penalties and margin for various cases against reference cases of a worst case link (WC), a worst case Tx and fiber with a reference Rx (RefRx) and a worst case Tx with a TDEC Rx (TDEC). The cases evaluate the best and worst case values for the attributes captured in the TDEC measurement.

•With the RefRx, the difference between a worst case Tx and best case Tx is 5.35 dB – 0.99 dB = 4.36 dB.

•With the TDEC Rx, the difference between a worst case Tx and best case Tx is 5.81 dB – 1.52 dB = 4.29 dB.

•Changing the max TDEC value in Table 95-6 from 4.9 to 4.3 is recommended.

•Above image comes from petrilla_01b_1014_optx, "100GBASE-SR4 TDEC & SEC Review" where the Example Link Model was used to provide an estimate of the max acceptable value for TDEC

Link Model Based Method For Estimating Max Acceptable TDEC Value (2/2)

	WC	TDEC WC	TDEC BC		RefRx WC	RefRx M=0	
Reach	100	2	2		100	100	
Uc	840	840	840		840	840	
Uw	0.60	0.60	0.60		0.60	0.60	
Transition time	21	21	1		21	21	
Prin	0.716	0.555	0		0.559	0.559	
Pmpn	0.097	0	0		0.097	0	
Pmn	0.116	0.116	0.116		0.116	0	
TP1 RJ (BER)	0.053	0.053	0		0.053	0.053	
TP1 DJ	0.110	0.110	0		0.110	0.110	
DCD	0.05	0.05	0		0.05	0.05	
TP3 DJ	0.251	0.251	0		0.251	0.251	
Rx DJ	0.052	0	0		0	0	
TP4 TJ	0.780	0.780	0.780		0.780	0.780	
BLW	0.025	0	0		0	0	
RxBW	18.05	12.6	12.6		19.34	19.34	
Signal Budget	8.48	8.61	8.61		8.61	8.61	
IL	1.86	1.51	1.51		1.86	1.86	
LP Pen	6.63	5.45	0.95		5.60	05.32	
Margin	-0.01	1.65	6.15	$\Delta = 4.50$	1.14	1.43	$\Delta = 0.29$

- The table contains a pair of columns with entries based on a TDEC measurement setup, i.e. a TDEC Rx with a BW of 12.6 GHz, a short test fiber, etc. One of the columns, TDEC WC, contains entries for a worst case Tx; the other, TDEC BC, for a best case Tx. The difference in margin for the two cases represents the difference in the penalties, Prin, Pcross & Pisi, capturing the effect of Pcross and providing the basis for the max acceptable TDEC value.

- The other pair of columns provide the basis for the effect of M1 & M2 in the TDEC calculation. One column represents a worst case Tx (RefRx WC) with a Ref Rx and the other with Pmpn and Pmn turned off.. Again the difference in margin for the pair represents the difference in penalties, here Pmn and Pmpn and captures the effect of Pcross.

- While it appears aligned with the link model analysis to use the sum of the two differences as the max acceptable TDEC value, initially a conservative approach was taken and the max acceptable TDEC value was based on just the difference between the TDEC best and worst cases with the allocation for Pmn and Pmpn included in this value.

100G SR4 – 400G SR16 Link Model Comparison: Channel Attributes

Parameter	Unit	100G SR4	400G SR16	
Signal rate	GBd	25.78125	26.5625	[1]
Q (BER)		3.8905 (5.0E-5)	3.5401 (2.0E-4)	[2]
Reach	m	100	100	
Fiber Attenuation	dB/km	3.5	3.5	At 850 nm center wavelength
Dispersion min Uo	nm	1316	1316	
Dispersion So	ps/nm ² km	0.10275	0.10275	
Fiber modal bandwidth at 840 nm CWL	MHz·km	4400	4400	
Reflection Noise Factor		0	0	
Pisi Central	dB	3.16	3.42	Model output
Signal power budget	dB	8.20	8.48	Model output
Connector & splice loss allocation	dB	1.50	1.50	
Fiber Insertion loss	dB	0.36	0.36	Model output
Link power penalties (includes Peye)	dB	6.34	6.63	Model output
Modal Noise Penalty	dB	0.129	0.116	Scaled with Q ²
Link Margin	dB	0	-0.01	Model output
Additional insertion loss allowed	dB	0	0	Model output

[1] Higher signal rate for RS(544, 514) FEC; $544/514 * 257/256 * 25G = 26.5625G$, see gustlin_3bs_02a_0315

[2] 100G SR4 uses RS(528, 514) FEC that corrects 5E-5 BER (random errors) to 1E-12 BER, 100% errors allocated to the optical segment. 400G SR16 uses RS(544, 514) FEC that corrects 3.2E-4 BER (random errors) to 1E-13 BER, 62.5% errors allocated to the optical segment.

100G SR4 – 400G SR16 Link Model Comparison: Tx Attributes

Parameter	Unit	100G SR4	400G SR16	
Signal rate	GBd	25.78125	26.5625	
Q (BER)		3.8905 (5.0E-5)	3.5401 (2.0E-4)	
Center Wavelength, min	nm	840	840	
Spectral Width, max	nm	0.60	0.60	
OMA, min	dBm	-3.0	-3.0	
Extinction ratio, min	dB	3.0	3.0	
Tx output transition times, 20% -80%, max	ps	21	21	
RIN ₁₂ OMA, max	dB/Hz	-128	-128	
RIN coefficient		0.7	0.7	
MPN coefficient		0.3	0.3	
Tx reflectance, max	dB	-12	-12	
Tx optical return loss tolerance, max	dB	12	12	
Tx & dispersion eye closure (TDEC), max	dB	4.3	4.5	TDEC(M1=M2=0)=4.21 dB

TDEC increases for 400G SR16 due to the shorter bit times leading to larger Pisi penalties, only partly compensated by the higher BER.

100G SR4 – 400G SR16 Link Model Comparison: Rx Attributes

Parameter	Unit	100G SR4	400G SR16	
Signal rate	GBd	25.78125	26.5625	
Q (BER)		3.8905 (5.0E-5)	3.5401 (2.0E-4)	
Center Wavelength, min	nm	840	840	
Rx sensitivity (OMA), max	dBm	-11.2	-11.48	Scales with Log(Q), Log(Signal Rate) & Log(Rx BW)
Rx Bandwidth, min	MHz	18,047	18,047	
RMS base line wander coefficient		0.025	0.025	
Rx reflectance, max	dB	-12	-12	
Rx stressed sensitivity	db	-5.16	-5.16	
Rx stressed eye closure (SEC), max	dB	4.3	4.5	Tracks change in TDEC

100G SR4 – 400G SR16 Link Model Comparison: Jitter Attributes

Parameter	Unit	100G SR4	400G SR16	
Signal rate	GBd	25.78125	26.5625	
Q (BER)		3.8905 (5.0E-5)	3.5401 (2.0E-4)	
TP1 RJrms tolerance, min	UI	0.0079	0.0079	Scales with signal rate; constant UI
TP1 DJ tolerance, min	UI	0.11	0.11	Scales with signal rate; constant UI
TP3 DCD tolerance, min	UI	0.05	0.05	Scales with signal rate; constant UI
TP3 DJ tolerance, min	UI	0.247	0.251	Tx & Rx DJ allocations fixed in ps
Cum DJ at TP4	UI	0.328	0.335	Tx & Rx DJ allocations fixed in ps
TP4 TJ at BER, max	UI	0.780	0.780	Forced model output

Fiber Optic Links Interfaces

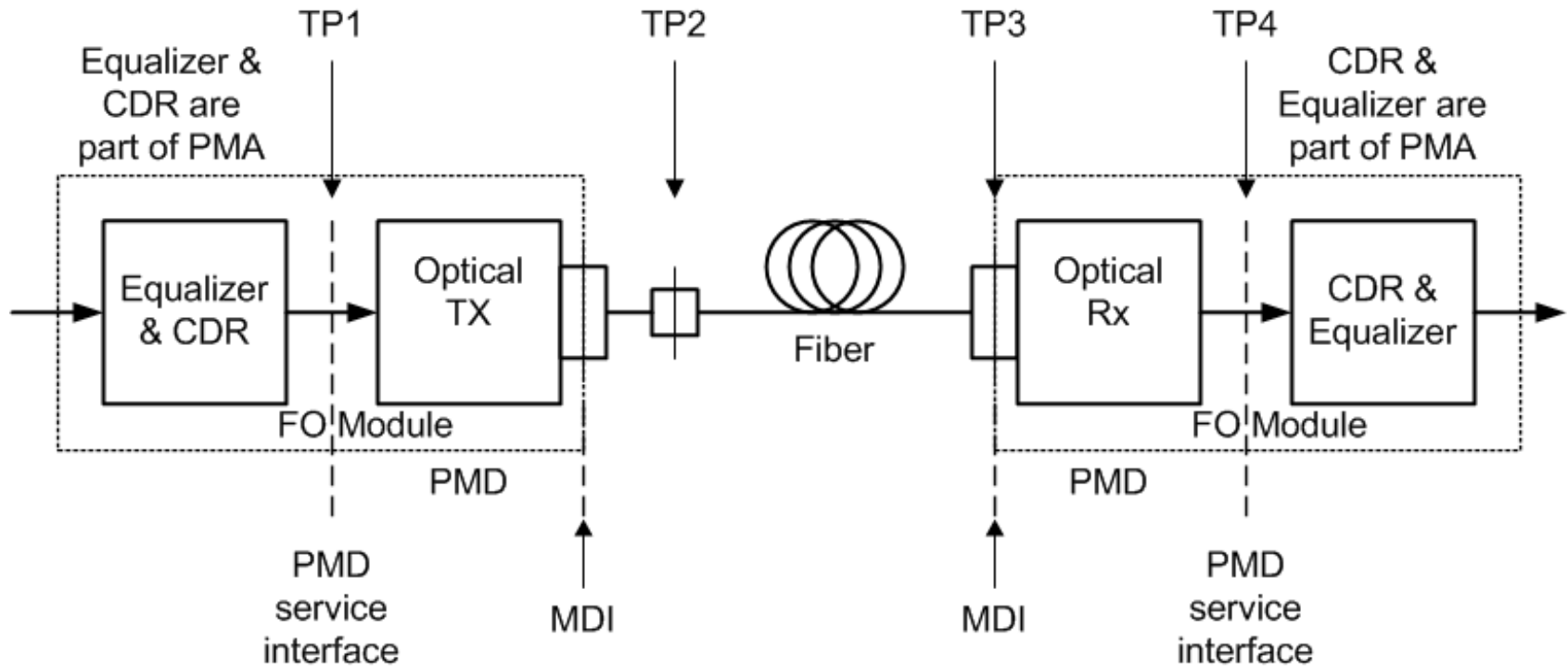

Figure 1

- For cases, as shown above in Figure 1, where retimers are embedded in the optical module, the PMD service interface is not exposed. TP1 and TP4 remain as points on the PMD service interface and, consequently, not exposed.
- The high speed signal inputs and outputs of these optical modules are expected to be defined by CDAUI-16.