

121.8.3 Average optical power

The average optical power of each lane shall be within the limits given in Table 121–6 if measured using the methods given in IEC 61280-1-1. The average optical power is measured using the test pattern defined in Table 121–10, per the test setup in Figure 53-6.

121.8.4 Outer Optical Modulation Amplitude (OMA_{outer})

The OMA_{outer} of each lane shall be within the limits given in Table 121–6 if measured using a test pattern specified for OMA_{outer} in Table 121–10. The OMA_{outer} is defined as the difference between the average optical launch power level P_3 , measured over the central 2 UI of a run of 7 threes, and the average optical launch power level P_0 , measured over the central 2 UI of a run of 6 zeros, as shown in Figure 121–3.

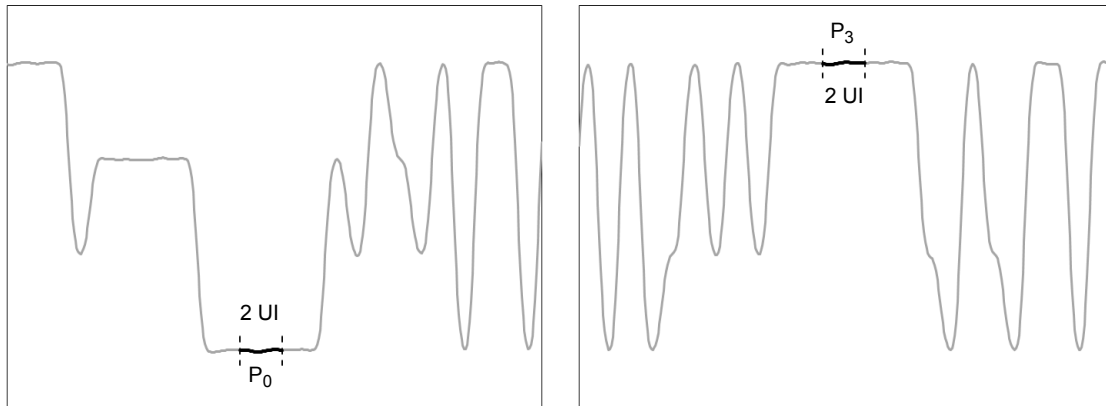

Figure 121–3—Example power levels P_0 and P_3 from PRBS13Q test pattern

121.8.5 Transmitter and dispersion eye closure for PAM4 (TDECQ)

The TDECQ of each lane shall be within the limits given in Table 121–6 if measured using the methods specified in 121.8.5.1, 121.8.5.2, and 121.8.5.3.

TDECQ is a measure of each optical transmitter's vertical eye closure when transmitted through a worst case optical channel (specified in 121.8.5.2), as measured through an optical to electrical converter (O/E) and oscilloscope with the combined frequency response given in 121.8.5.1, and equalized with the reference equalizer (as described in 121.8.5.4). The reference receiver and equalizer may be implemented in software or may be part of an oscilloscope.

Table 121–10 specifies the test patterns to be used for measurement of TDECQ.

121.8.5.1 TDECQ conformance test setup

A block diagram for the TDECQ conformance test is shown in Figure 121–4. Other equivalent measurement implementations may be used with suitable calibration.

Each optical lane is tested individually with all other lanes in operation and all lanes using the same test pattern. There shall be at least 31 UI delay between the test pattern on one lane and the pattern on any other lane. The optical splitter and variable reflector are adjusted so that each transmitter is tested with the optical return loss specified in Table 121–11. The state of polarization of the back reflection is adjusted to create the greatest RIN. Each optical lane is tested with the optical channel described in 121.8.5.2. The combination of the O/E and the oscilloscope has a fourth-order Bessel-Thomson filter response with a bandwidth of

19.34 GHz. Compensation may be made for any deviation from an ideal fourth-order Bessel-Thomson response.

The test pattern (specified in Table 121–10) is transmitted repetitively by the optical lane under test and the oscilloscope is set up to capture the complete pattern for TDECQ analysis as described in 121.8.5.3. The clock recovery unit (CRU) has a corner frequency of 4 MHz and a slope of 20 dB/decade. The CRU can be implemented in hardware or software depending on oscilloscope technology.

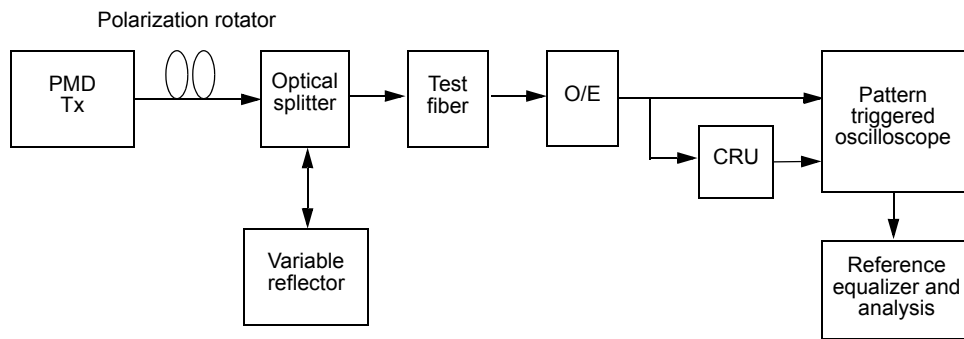

Figure 121–4—TDECQ conformance test block diagram

121.8.5.2 Channel requirements

The transmitter is tested using an optical channel that meets the requirements listed in Table 121–11.

Table 121–11—Transmitter compliance channel specifications

PMD type	Dispersion ^a (ps/nm)		Insertion loss ^b	Optical return loss ^c	Max mean DGD
	Minimum	Maximum			
200GBASE-DR4	$0.011625 \times \lambda \times [1 - (1324 / \lambda)^4]$	$0.011625 \times \lambda \times [1 - (1300 / \lambda)^4]$	Minimum	21.4 dB	0.5 ps

^aThe dispersion is measured for the wavelength of the device under test (λ in nm). The coefficient assumes 500 m for 200GBASE-DR4.

^bThere is no intent to stress the sensitivity of the O/E converter associated with the oscilloscope.

^cThe optical return loss is applied at TP2.

A 200GBASE-DR4 transmitter is to be compliant with a total dispersion at least as negative as the “minimum dispersion” and at least as positive as the “maximum dispersion” columns specified in Table 121–11 for the wavelength of the device under test. This may be achieved with channels consisting of fibers with lengths chosen to meet the dispersion requirements.

To verify that the fiber has the correct amount of dispersion, the measurement method defined in IEC 60793-1-42 may be used. The measurement is made in the linear power regime of the fiber.

The channel provides an optical return loss specified in Table 121–11. The state of polarization of the back reflection is adjusted to create the greatest RIN.

The mean DGD of the channel is to be less than the value specified in Table 121–11.

121.8.5.3 TDECQ measurement method

The standard deviation of the noise of the O/E and oscilloscope combination, σ_S , is determined with no optical input signal and the same settings as used to capture the histograms described below.

OMA_{outer} is measured according to 121.8.4 on the equalized signal.

The test pattern specified for TDECQ (see Table 121–10) is transmitted repetitively by the optical lane under test and the oscilloscope is set up to capture samples from all symbols in the complete pattern.

If an equivalent-time sampling oscilloscope is used, the impact of the sampling process and the reference equalizer on transmitter noise must be compensated for, so that the correct magnitude of noise is present at the output of the equalizer.

The captured waveform is processed to find the largest noise that could be convolved with the signal by an ideal reference receiver when optimally equalized by a reference equalizer. The optimal equalizer tap coefficients are dependent on the amount of noise that can be added to the signal, so finding the noise that can be added and the optimal equalizer setting is an iterative process. One way of doing this, using estimated PAM4 symbol error ratio as the figure of merit for the equalized signal, is described below.

The reference equalizer (specified in 121.8.5.4) is applied to the waveform. The sum of the equalizer tap coefficients is equal to 1. An eye diagram is formed from the equalized captured waveform.

The average optical power (P_{ave}) of the equalized eye diagram is determined, and the 0 UI and 1 UI crossing points are determined by the average of the eye diagram crossing times, as measured at P_{ave} , as illustrated in Figure 121–5.

Two vertical histograms are measured through the eye diagram, centered at 0.45 UI and 0.55 UI. Each of the histogram windows spans all of the modulation levels of the eye diagram, as illustrated in Figure 121–5.

Each histogram window has a width of 0.04 UI. Each histogram window has outer height boundaries which are set beyond the extremes of the eye diagram (so that no further samples would be captured by increasing the vertical separation of the height boundaries).

1
2
3
4
5
6
7
8
9
10
11
12
13
14
15
16
17
18
19
20
21
22
23
24
25
26
27
28
29
30
31
32
33
34
35
36
37
38
39
40
41
42
43
44
45
46
47
48
49
50
51
52
53
54

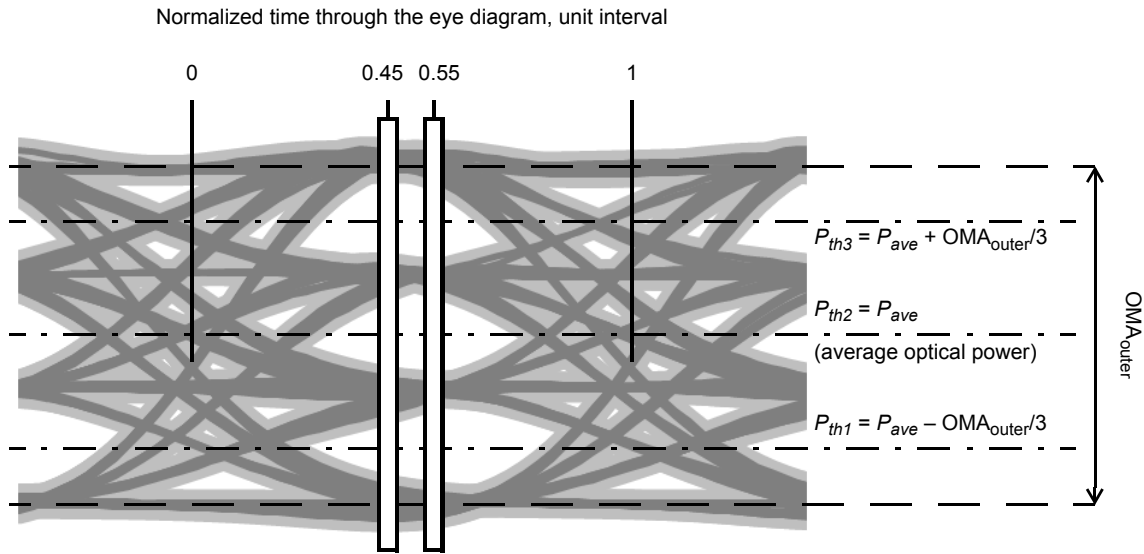

Figure 121-5—Illustration of the TDECQ measurement

The sub-eye threshold levels P_{th1} , P_{th2} , and P_{th3} , are determined from the OMA_{outer} and the average optical power of the eye diagram (P_{ave}) as defined in Equation (121-1), Equation (121-2), and Equation (121-3) and illustrated in Figure 121-5.

$$P_{th1} = P_{ave} - \frac{OMA_{outer}}{3} \quad (121-1)$$

$$P_{th2} = P_{ave} \quad (121-2)$$

$$P_{th3} = P_{ave} + \frac{OMA_{outer}}{3} \quad (121-3)$$

Each captured histogram is processed to, in effect, convolve the PAM4 waveform with noise, in order to produce an estimate of the partial PAM4 symbol error ratio (SER) for each sub-eye. One way of doing this is described below.

The left and right histograms are each normalized, and can be represented as a series of equally spaced optical power values (y_i) with separation Δy , each with an associated fraction $F(y_i)$, equal to the number of samples captured in that power interval divided by the total number of samples in that histogram. The sum of all $F(y_i)$ for each histogram is equal to 1.

From the left normalized histogram $F(y_i)$, three cumulative probability functions are created, $CF_{L1}(y_i)$, $CF_{L2}(y_i)$, and $CF_{L3}(y_i)$, one around each sub-eye threshold. The right histogram is treated similarly to create three cumulative probability functions $CF_{R1}(y_i)$, $CF_{R2}(y_i)$, and $CF_{R3}(y_i)$. $CF_{L1}(y_i)$ is defined in Equation (121-4).

1
2
3
4
5
6
7
8
9
10
11
12
13
14
15
16
17
18
19
20
21
22
23
24
25
26
27
28
29
30
31
32
33
34
35
36
37
38
39
40
41
42
43
44
45
46
47
48
49
50
51
52
53
54

$$CF_{L1}(y_i) = \begin{cases} y_i \\ \sum_{y=P_{th1}}^{y_i} F(y) \text{ for } y_i \geq P_{th1} \\ P_{th1} \\ \sum_{y=y_i}^{P_{th1}} F(y) \text{ for } y_i < P_{th1} \\ y=y_i \end{cases} \quad (121-4)$$

Each element of the cumulative probability function, $CF_{L1}(y_i)$, is multiplied by a value $G_{th1}(y_i)$, and then summed to calculate an approximation for SER_{L1} , the partial SER for threshold 1. Each element of the cumulative probability function, $CF_{L2}(y_i)$, is multiplied by a value $G_{th2}(y_i)$, and then summed to calculate an approximation for SER_{L2} . Each element of the cumulative probability function, $CF_{L3}(y_i)$, is multiplied by a value $G_{th3}(y_i)$, and then summed to calculate an approximation for SER_{L3} . The sum of the three partial SERs is the SER associated with the left histogram, SER_L .

Each element of the cumulative probability function, $CF_{R1}(y_i)$, is multiplied by a value $G_{th1}(y_i)$, and then summed to calculate an approximation for SER_{R1} , the partial SER for threshold 1. $CF_{R2}(y_i)$ and $CF_{R3}(y_i)$ are treated similarly to calculate SER_{R2} , and SER_{R3} , the partial SERs for threshold 2 and threshold 3. The sum of the three partial SERs is the SER associated with the right histogram, SER_R .

$G_{th1}(y_i)$ is equivalent to a Gaussian probability density function with an RMS value of σ_G centered around the sub-eye threshold P_{th1} . $G_{th1}(y_i)$ is given by Equation (121-5) and can be estimated by Equation (121-6).

$$G_{th1}(y_i) = \int_{y_i - \frac{\Delta y}{2}}^{y_i + \frac{\Delta y}{2}} \frac{1}{C_{eq} \sigma_G \sqrt{2\pi}} \times e^{-\left(\frac{y_i - P_{th1}}{C_{eq} \sigma_G \sqrt{2}}\right)^2} dy \quad (121-5)$$

$$G_{th1}(y_i) = \frac{1}{C_{eq} \sigma_G \sqrt{2\pi}} \times e^{-\left(\frac{y_i - P_{th1}}{C_{eq} \sigma_G \sqrt{2}}\right)^2} \times \Delta y \quad (121-6)$$

$G_{th2}(y_i)$ and $G_{th3}(y_i)$ are similar Gaussian probability density functions with the same RMS value of σ_G centered around the sub-eye thresholds P_{th2} and P_{th3} respectively. $G_{th2}(y_i)$ and $G_{th3}(y_i)$ are given by Equation (121-7) and Equation (121-8) respectively.

$$G_{th2}(y_i) = \int_{y_i - \frac{\Delta y}{2}}^{y_i + \frac{\Delta y}{2}} \frac{1}{C_{eq} \sigma_G \sqrt{2\pi}} \times e^{-\left(\frac{y_i - P_{th2}}{C_{eq} \sigma_G \sqrt{2}}\right)^2} dy \quad (121-7)$$

$$G_{th3}(y_i) = \int_{y_i - \frac{\Delta y}{2}}^{y_i + \frac{\Delta y}{2}} \frac{1}{C_{eq} \sigma_G \sqrt{2\pi}} \times e^{-\left(\frac{y_i - P_{th3}}{C_{eq} \sigma_G \sqrt{2}}\right)^2} dy \quad (121-8)$$

where

C_{eq} is a coefficient which accounts for the reference equalizer noise enhancement

The value of C_{eq} can be calculated from the product of the normalized noise power density spectrum $N(f)$ at the input of the reference equalizer and the normalized frequency response $H_{eq}(f)$ of the reference equalizer, as shown in Equation (121–9).

$$C_{eq} = \sqrt{\int_f N(f) \times H_{eq}(f) df} \quad (121-9)$$

where

$N(f)$ is the normalized noise power density spectrum equivalent to white noise filtered by a fourth-order Bessel-Thomson response filter with a bandwidth of 19.34 GHz.

and

$$\int_f N(f) df = H_{eq}(f=0) = 1 \quad (121-10)$$

The equalizer tap coefficients are iteratively adjusted and SER_L and SER_R calculated until the largest of SER_L and SER_R is minimized. Then, if the larger of SER_L and SER_R is greater than the target SER of 4.8×10^{-4} , the value of σ_G is decreased and the process of equalizer optimization is repeated; If the larger of SER_L and SER_R is lower than the target SER of 4.8×10^{-4} , then the value of σ_G is increased and the process of equalizer optimization is repeated.

When the larger of SER_L and SER_R is equal to the target SER of 4.8×10^{-4} , and the value of σ_G cannot be increased by further optimization of the equalizer tap coefficients, then TDECQ is calculated.

The noise, R , that could be added by a receiver is given by Equation (121–11).

$$R = \sqrt{\sigma_G^2 + \sigma_S^2} \quad (121-11)$$

TDECQ is given by Equation (121–12).

$$TDECQ = 10\log_{10}\left(\frac{OMA_{outer}}{6} \times \frac{1}{Q_t R}\right) \quad (121-12)$$

where

OMA_{outer} is the Outer Optical Modulation Amplitude as defined in 121.8.4
 Q_t is 3.414 consistent with the BER and target symbol error ratio for Gray coded PAM4

121.8.5.4 TDECQ reference equalizer

The reference equalizer for 200GBASE-DR4 is a 5 tap, T/2 spaced, feed-forward equalizer (FFE), where T is the symbol period.

NOTE—This reference equalizer is part of the TDECQ test and does not imply any particular receiver equalizer implementation.

121.8.6 Extinction ratio

The extinction ratio of each lane shall be within the limits given in Table 121–6 if measured using a test pattern specified for extinction ratio in Table 121–10. The extinction ratio of a PAM4 optical signal is