



IEEE802.3 4P Task Force

**Derivation of PSE and PD PI Rmax, Rmin in
order to meet system worst case End to End
Pair To pair effective resistance unbalance**

June 2015

Rev 013a

Yair Darshan / Microsemi yadarshan@microsemi.com

Ken Bennett / Sifos

Derivation of PSE and PD PI Rmax, Rmin Equation limits that meets system worst case End to End Pair To pair effective resistance unbalance. Yair Darshan, June 2015 Rev 013a.

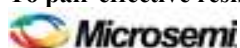

Contents

PD Base line TEXT	3
Derivation of PSE and PD PI Requirements.....	4
Pair to pair current and resistance unbalance - Background	4
Derivation of PD PI Requirements	5
Example Usage for PD PI P2P_unb specifications.....	9
Derivation of PSE PI Requirements.....	12
Example Usage for PSE PI P2P_unb specifications.....	15
Annex A – Additional Research conclusions.....	18
Annex B Derivation of PSE Rmax, Rmin equation for PSE PI test setup.....	20
References.....	21

Derivation of PSE and PD PI Rmax, Rmin Equation limits that meets system worst case End to End Pair To pair effective resistance unbalance. Yair Darshan, June 2015 Rev 013a.

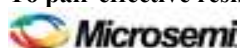

PD Base line TEXT

33.3.7.10 PD PI Pair to Pair resistance and current unbalance.

Type 3 PDs that are class 5 and above and Type 4 PDs from class 7 and above shall meet the following requirements when tested using the test setup and test conditions specified in 33.3.7.10.1:

The current measured at any pair shall not exceed $I_{cont-2P_{unb}}$ as specified in Table 33-11 item 4a.

See Annex C for design guide lines for meeting the above requirements.

33.3.7.10.1: Test setup and test conditions for PD PI pair to pair resistance and current unbalance.

The test setup described in Figure TBD369 and its test conditions shall be used to verify that the requirements in clause 33.3.7.10 are met.

[Editor Note: Extended power will be addressed in separate work]

Test conditions:

Item	Parameter	Value	Additional Information
1	Vin	Vport_PSE-2P_min	
2	Rpair_min	0.16Ω ±1%	
3	Rpair_max	0.190Ω ±1%	
4	PD power	Set to Maximum per its class.	

Table TBD123: Test conditions and test requirements for PD PI P2P_iunb and Runb Test setup

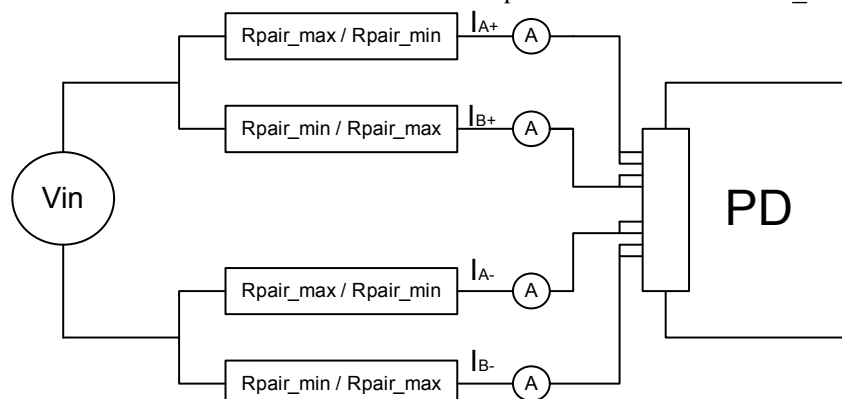

Figure TBD369: PD PI pair to pair resistance and current unbalance test setup

Rpair_max, Rpair_min represents PSE and Channel effective source impedance that includes the effect of Vport_PSE_diff as specified by Table 33-11 item 1a.

Derivation of PSE and PD PI Rmax, Rmin Equation limits that meets system worst case End to End Pair To pair effective resistance unbalance. Yair Darshan, June 2015 Rev 013a.

An nex C [Informative]

The following guide design guide lines may be implemented to ensure meeting PD PI P2P_Iunb requirements:

For PD Type 4 class 8: $R_{\text{pair_max_pd}} = 1.760 * R_{\text{pair_min_pd}} + 0.089$.

For PD Type 4 class 7: $R_{\text{pair_max_pd}} = k1 \text{ (TBD)} * R_{\text{pair_min_pd}} + k_{pd1} \text{ (TBD)}$.

For PD Type 3 class 6: $R_{\text{pair_max_pd}} = 1.8925 * R_{\text{pair_min_pd}} + 0.109$. (Equation TBD246)

For PD Type 3 class 5: $R_{\text{pair_max_pd}} = k2 \text{ (TBD)} * R_{\text{pair_min_pd}} + k_{pd2} \text{ (TBD)}$

Editor Note: To complete the explanation and definitions of $R_{\text{pair_max_pd}}$ and $R_{\text{pair_min_pd}}$ per class.

The following is the mathematical analysis and derivation of the P2P_Iunb/Runb requirements for the PD and PSE PI.

Derivation of PSE and PD PI Requirements

Pair to pair current and resistance unbalance - Background

In a system that delivers power over all its four pairs, i.e. the power is delivered over two power channels, Alternative A pairs and Alternative B pairs. The current on Alternative A positive wires will typically be different than the current through Alternative B positive wires. The same will happen in the negative Alternative A and Alternative B wires. This is caused by the resistance difference between the wire pairs, the resistance of components in series with these wires, and different voltage drops across components such as diodes and/or different voltages between the pairs of the same polarity at the PSE power supply feeding point. See figure 1 for details.

Derivation of PSE and PD PI Rmax, Rmin Equation limits that meets system worst case End to End Pair To pair effective resistance unbalance. Yair Darshan, June 2015 Rev 013a.

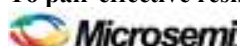

It can be shown that the current difference between two pairs of the same polarity is a function of the resistance difference between those pairs.

The current difference between two pairs is defined as $I_{diff}=|I_A - I_B|$. The pair to pair current unbalance ($E2E_P2PIunb$) is a ratio and defined as I_{diff}/I_t where I_t is the total current of both pairs i.e. $I_t=I_A + I_B$.

As a result, $E2E_P2PIunb = \left| \frac{I_A - I_B}{I_A + I_B} \right|$. It can be shown that $E2E_P2PIunb$ is proportional to the pair to pair effective resistance unbalance between the two pairs of the same polarity i.e.

$$E2E_P2PRunb = \frac{\sum R_{max} - \sum R_{min}}{\sum R_{max} + \sum R_{min}}$$

It is possible to derive simplified equations when effective resistance values are used for R_{max} and R_{min} because it eliminates the use of PSE V_{diff} and PD V_{diff} parameters in the equations.

The effective R_{max} , R_{min} values are the real static R_{max} and R_{min} values with some addition or reduction from their nominal values to account for the effect of PSE V_{diff} and PD V_{diff} on the pair to pair current unbalance in addition to the effect of the pair to pair resistance to the pair to pair current unbalance.

When effective resistance values are used, the following terms are identical:

$$E2E_P2PIunb = E2E_P2PRunb$$

The effective R_{max} and R_{min} are found by measuring the voltage V_{eff} , from PSE power supply positive node (not the point of PSE voltage + V_{diff}) to the other pair end. I_{A+} and I_{B+} are measured. Assuming that pair $A+$ is with the minimum resistance and pair $B+$ is with the maximum resistance then $R_{max_eff}=V_{eff}/I_{A+}$ and $R_{min_eff}=V_{eff}/I_{B+}$. Same is done for negative pairs. See Figure 1 for details.

Due to the fact that the measured current I is a result of all of the pair to pair unbalance sources, the effective resistance is also representing the PSE pair to pair voltage differences and the PD pair to pair voltage differences.

For a PSE designer it is useful to have specifications for the nominal component resistance values. PSE components which cause significant differences between effective values and nominal resistance values, such as series forward biased diodes, will typically not be included in R_{max} and R_{min} as they reduce efficiency and will not allow the system maximum V_{diff} specification to be met. For the PD designer the effective resistance values are generally necessary due to the widespread use of diode bridges. However for testing the PD for compliance, it will be best accomplished by measuring the PD input current per pair-set of the same polarity and verifying that maximum pair current of $I_{cont-2P_unb}$ of Table 33-11 item 4a is not violated. When we get to the specification part, it will be shown how to derive the convenient specification.

Derivation of PD PI Requirements

The following is the End to End Pair to Pair Resistance Unbalance ($E2E_P2PRunb$ or “ α ”) equation for a system including PSE, PD and Channel (cables and connectors).

Derivation of PSE and PD PI R_{max} , R_{min} Equation limits that meets system worst case End to End Pair To pair effective resistance unbalance. Yair Darshan, June 2015 Rev 013a.

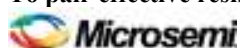

$$(1) \quad \alpha = E2E_P2PRunb = \frac{\left(\sum_{R_{max}} PSE - \sum_{R_{min}} PSE\right) + \left(\sum_{R_{max}} PD - \sum_{R_{min}} PD\right) + \left(\sum_{R_{max}} CH - \sum_{R_{min}} CH\right)}{\left(\sum_{R_{max}} PSE + \sum_{R_{min}} PSE\right) + \left(\sum_{R_{max}} PD + \sum_{R_{min}} PD\right) + \left(\sum_{R_{min}} CH + \sum_{R_{max}} CH\right)}$$

All resistance values are effective resistances, which mean that the values include the effects of non-linear components at their operating point and the effects of pair-to-pair voltage differences in both the PSE and PD.

(2) The PD PI P2PRUNB is:

$$PD_P2PRunb = \frac{\left(\sum_{R_{max}} PD - \sum_{R_{min}} PD\right)}{\left(\sum_{R_{max}} PD + \sum_{R_{min}} PD\right)}$$

(3) The PD PI P2PRUNB contribution to the E2E_P2PRunb of the system is

$$PD_P2PRUNB_contribution = \frac{\left(\sum_{R_{max}} PD - \sum_{R_{min}} PD\right)}{\left(\sum_{R_{max}} PSE + \sum_{R_{min}} PSE\right) + \left(\sum_{R_{max}} PD + \sum_{R_{min}} PD\right) + \left(\sum_{R_{min}} CH + \sum_{R_{max}} CH\right)}$$

We can see that PD contribution (3) is not equal to PD PI P2PRUNB (2).

As a result we need to transform PD_P2PRUNB (2) to PD_P2PRUNB_contribution (3) in order to have the correct weight of the PD in the whole system defined by (1) i.e. to find the function Fx that satisfies the worst case E2E_P2PRunb at the maximum PD Type operating power (which is not necessarily the point of maximum pair current).

$$\frac{\left(\sum_{R_{max}} PD - \sum_{R_{min}} PD\right)}{\left(\sum_{R_{max}} PD + \sum_{R_{min}} PD\right)} \cdot Fx = \frac{\left(\sum_{R_{max}} PD - \sum_{R_{min}} PD\right)}{\left(\sum_{R_{max}} PSE + \sum_{R_{min}} PSE\right) + \left(\sum_{R_{max}} PD + \sum_{R_{min}} PD\right) + \left(\sum_{R_{min}} CH + \sum_{R_{max}} CH\right)}$$

This step will in turn provide the equation that defines the relationship between RPDmin and RPDmax in terms of effective resistance values. e.g. if Rmin is selected by the designer, then the corresponding maximum allowable value of Rmax that will not exceed the E2E_P2PRunb limit will be provided (Just specifying Rmax/Rmin ratio will not work for our objective above).

There are few ways to do this task. The following is a simple analytical transformation process:

Describing (1) as a system that includes all parts:

Derivation of PSE and PD PI P2PRUNB Equation limits that meets system worst case End to End Pair To pair effective resistance unbalance, Fair Darshan, June 2015 Rev 013a.



(4)

Opening and solving for Rmax/Rmin in terms of α .

$$\begin{aligned}
 (5) \quad & \left(\sum R_{\max} - \sum R_{\min} \right) = \alpha \cdot \left(\sum R_{\max} + \sum R_{\min} \right) \\
 & \sum R_{\max} - \sum R_{\min} = \alpha \cdot \sum R_{\max} + \alpha \cdot \sum R_{\min} \\
 & \sum R_{\max} - \alpha \cdot \sum R_{\max} = +\alpha \cdot \sum R_{\min} + \sum R_{\min} \\
 & (1 - \alpha) \cdot \sum R_{\max} = (1 + \alpha) \cdot \sum R_{\min} \\
 & \frac{\sum R_{\max}}{\sum R_{\min}} = \frac{(1 + \alpha)}{(1 - \alpha)} = u
 \end{aligned}$$

As a result from (5):

$$\begin{aligned}
 (6) \quad & \frac{\sum R_{\max}}{\sum R_{\min}} = u \\
 & u \cdot \sum R_{\min} - \sum R_{\max} = 0
 \end{aligned}$$

The E2E_P2PRunb equation from (1) or its simpler form (4) can be expressed in the following form:

$$(7) \quad U \cdot \sum R_{\min} - \sum R_{\max} = 0, \quad \text{Where } U = \frac{1 + \alpha}{1 - \alpha}$$

Separating the contributors PSE, PD and Channel results in:

$$\begin{aligned}
 (8) \quad & (U \cdot R_{PSEmin} - R_{PSEmax}) + (U \cdot R_{CHmin} - R_{CHmax}) + (U \cdot R_{PDmin} - R_{PDmax}) \\
 & = Cont_{PSE} + Cont_{CH} + Cont_{PD} = 0
 \end{aligned}$$

Each contributor is a constant in the worst case model:

$$Cont_{PSE} + Cont_{CH} + Cont_{PD} = 0$$

And a contributor can be solved independently to meet an E2ERunb limit, given the worst case scenario:

Derivation of PSE and PD PI Rmax, Rmin Equation limits that meets system worst case End to End Pair To pair effective resistance unbalance. Yair Darshan, June 2015 Rev 013a.

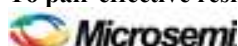

$$(10) \quad (U \cdot R_{PSEmin} - R_{PSEmax}) + (U \cdot R_{CHmin} - R_{CHmax}) + (U \cdot R_{PDmin} - R_{PDmax}) = \\ Cont_{pse} + Cont_{CH} + Cont_{PD} = 0$$

$$(11) \quad (U \cdot R_{PDmin} - R_{PDmax}) + Cont_{PSE} + Cont_{CH} = 0$$

Simplifying further by combining the constants:

$$K_{pd} = Cont_{PSE} + Con_{CH}$$

$$(12) \quad (U \cdot R_{PDmin} - R_{PDmax}) + K_{pd} = 0$$

Solving for Rmax expressed as a range with a worst case limit results in:

$$(13) \quad R_{PDmax} \leq U \cdot R_{PDmin} + K_{PD}$$

Where:

U is a constant determined by the target end to end pair to pair resistance/current unbalance.

K_{PD} is a constant derived for the PD and Channel contribution to the worst case E2ERunb.

R_{PDmin} and R_{PDmax} are the effective PD PI resistances.

[See Example next page.](#)

Example Usage for PD PI P2P_unb specifications

Assuming that the following represents a system that is considered to be a worst case system in terms of the components it uses, operation at maximum operating power, and at the practical shortest channel length[m] (i.e. the minimum Channel Rmax, Rmin.). The Rpair values below are the nominal resistances. Effective resistances, which include the Vdiff parameter effects, are determined in a simulation and are shown below as well.

1. PSE has PSE_Vdiff=2mV as specified in Table 33-11 item 1a in 802.3bt Draft D0.4 and PD Vdiff=58mV in order to maintain total system Vdiff of 60mV. The PD will be checked for compliance by checking its pairs maximum current is not exceeding Icon-2P_unb in Table 33-11 item 4a as specified in IEEE802.3Draft D0.4. The test setup will be constructed by a voltage source which its PSE Vdiff effect is embedded by the effective resistance of the PSE + Channel parts (*Effective resistance is the resistance that includes voltage difference effect. We can convert PSE Vdiff to a resistance difference that is added to the other system components*). This concept of using PSE +CH effective resistance will allow us to use simple voltage source without PSE Vdiff component which is hard to implement. The following are the nominal Rmax, Rmin of the system components:
2. PD: Rpair_max_{pd} = 0.09 Rpair_min_{pd} = 0.075
3. Channel : Rpair_max_{ch} = 0.1005 Rpair_min_{ch} = 0.0909
4. PSE: Rpair_max_{pse} = 0.091 Rpair_min_{pse} = 0.076
5. Channel length =2.65m , Rch_max=0.1Ω Rch_min=0.0857Ω
6. PD_Vdiff=58mV

For Type 3: PD input power, Ppd=51W

The effective resistance of the PSE + Channel (measured by simulations in order to find effective resistance values under the above conditions. See Figure 1 and Annex A as for how to find effective resistance): Rpair_max_{pse+ch} = 0.1915 Rpair_min_{pse+ch} = 0.1587

Initial Determination of E2ERunb and Kpd using worst case simulation values of example system:

$$\frac{\sum R_{max} - \sum R_{min}}{\sum R_{max} + \sum R_{min}} = E2ER_{unb} = 0.3086$$

Derive PD Specification:

$$U = \frac{1 + E2ER_{unb}}{1 - E2ER_{unb}} = 1.8925$$

$$Kpd = [Rpair_{min_{pse+ch}} * U - Rpair_{max_{pse+ch}}] = 0.1587 * 1.8925 - 0.1915 = 0.109$$

Specification becomes:

$$Rpair_{max_{pd}} = 1.8925 * Rpair_{min_{pd}} + 0.109.$$

Cross-Check:

Arbitrary PD Rpair_min = 0.05

PD Rpair_max limits Calculated with above equation:

$$Rpair_{max_{pd}} = 1.8925 * Rpair_{min_{pd}} + 0.109 = 1.8925 * 0.05 + 0.109 = 0.203$$

(The above values of PD Rpairmax and Rpair min should meet the E2ERunb limit with the worst case pse+ch values represented by U and Kpd above):

Derivation of PSE and PD PI Rmax, Rmin Equation limits that meets system worst case End to End Pair To pair effective resistance unbalance. Yair Darshan, June 2015 Rev 013a.

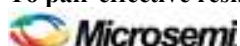

Any PD that uses $R_{\text{pair_max_pd}} \leq 0.203$ and $R_{\text{pair_min_pd}} = 0.05$ with the worst case source: $R_{\text{pair_max_pse+ch}} = 0.1915$ and $R_{\text{pair_min_pse+ch}} = 0.1587$ will meet the E2ERunb Limit:

$$E2ERunb = [(0.203+0.1915)-(0.05+0.1587)] / [(0.203+0.1915)+(0.05+0.1587)] = 0.3086$$

For Type 4: PD input power, Ppd=71.3W

PSE + CH (measured by simulations in order to find effective resistance values under the above conditions): $R_{\text{pair_max_pse+ch}} = 0.1915$ $R_{\text{pair_min_pse+ch}} = 0.1595$

(No surprise that it is similar values for Type 3 for PSE+CH due to the fact that most of the effect on E2EP2P_unb is due to the PD side and PSE Vdiff is relatively small in this analysis.)

Initial Determination of E2ERunb and Kpd using worst case simulation values of example system:

$$\frac{\sum R_{\text{max}} - \sum R_{\text{min}}}{\sum R_{\text{max}} + \sum R_{\text{min}}} = E2ER_{\text{unb}} = 0.275$$

Derive PD Specification:

$$U = \frac{1 + E2ER_{\text{unb}}}{1 - E2ER_{\text{unb}}} = 1.76$$

$$K_{\text{pd}} = [R_{\text{pair_min_pse+ch}} * U - R_{\text{pair_max_pse+ch}}] = 0.1595 * 1.76 - 0.1915 = 0.089$$

Specification becomes:

$$R_{\text{pair_max_pd}} = 1.760 * R_{\text{pair_min_pd}} + 0.089.$$

Cross-Check:

Arbitrary PD $R_{\text{pair_min}} = 0.05$

PD $R_{\text{pair_max}}$ limits Calculated with above equation:

$$R_{\text{pair_max_pd}} = 1.75 * R_{\text{pair_min_pd}} + 0.085 = 1.75 * 0.05 + 0.085 = 0.203$$

(The above values of PD $R_{\text{pair_max}}$ and $R_{\text{pair_min}}$ should meet the E2ERunb limit with the worst case pse+ch values represented by U and Kpd above):

Any PD that uses $R_{\text{pair_max_pd}} \leq 0.203$ and $R_{\text{pair_min_pd}} = 0.05$ with the worst case source: $R_{\text{pair_max_pse+ch}} = 0.1915$ and $R_{\text{pair_min_pse+ch}} = 0.1595$ will meet the E2ERunb Limit:

$$E2ERunb = [(0.203+0.1915)-(0.05+0.1595)] / [(0.203+0.1915)+(0.05+0.1595)] = 0.2756$$

Derivation of PSE and PD PI Rmax, Rmin Equation limits that meets system worst case End to End Pair To pair effective resistance unbalance. Yair Darshan, June 2015 Rev 013a.



Summary:

The PD PI Pair to pair unbalances specifications will use the following requirements:

- PDs will have to meet $I_{port-2P_unb}$ maximum value per Table 33-11.
- Testing for compliance will be done by using PSE and Channel **effective** $R_{pair_max/min}$ values shown in this work that includes PSE V_{diff} effect.
 - Using this technique will simplify the test setup and will require simple voltage source only as shown below.
- The following test set up model and its numbers is meant to be used only at maximum Type 3 and Type 4 power. For measuring pair to pair unbalance at low current, the values of the effective $R_{pair_min/max}$ need to be updated accordingly. Measuring pair to pair unbalance at low current is not required for the IEEE802.3bt D0.4 or D1.0.

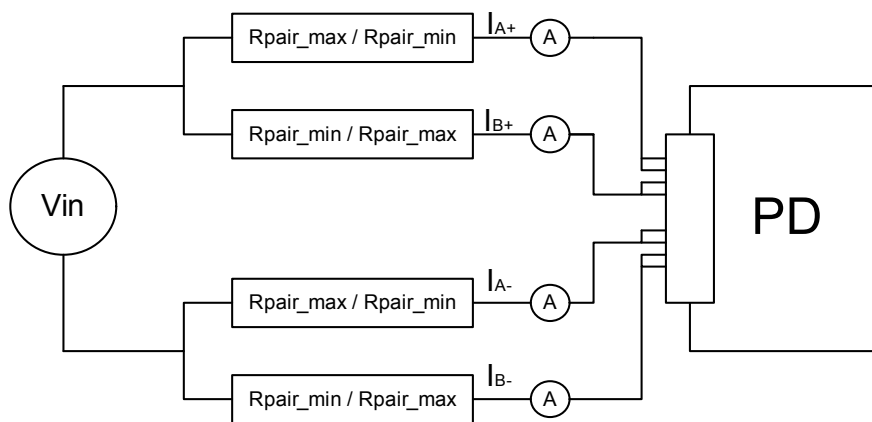

R_{pair_max} , R_{pair_min} represents PSE and Channel effective source impedance over each pair.

Test setup calculated R_{pair_max} and R_{pair_min} values:

Type 3: $R_{pair_max_{pse+ch}} = 0.1915$

$R_{pair_min_{pse+ch}} = 0.1587$

Type 4: $R_{pair_max_{pse+ch}} = 0.1915$

$R_{pair_min_{pse+ch}} = 0.1595$

Rounding R_{max} down and rounding up R_{min} Resulting with the same R_{max} , R_{min} for Type 3 and 4:

$R_{pair_max_{pse+ch}} = R_{pair_max} = 0.190\Omega \pm 1\%$

$R_{pair_min_{pse+ch}} = R_{pair_min} = 0.16\Omega \pm 1\%$

In the informative Annex of the PD PI P2P I_{unb} we will have the following design guideline that will help the designer to make sure that if it met, he will meet the $I_{port-2P_unb}$ as well.

The Guidelines for effective $R_{pair_max_{pd}}$ and $R_{pair_min_{pd}}$:

(may not be needed for the specifications).

For Type 3: $R_{pair_max_{pd}} = 1.893 * R_{pair_min_{pd}} + 0.109$.

For Type 4: $R_{pair_max_{pd}} = 1.75 * R_{pair_min_{pd}} + 0.089$.

When tested with the above test setup. PSE V_{diff} is embedded in $R_{min/Max}$ as a result, only DC voltage source with PSE operating voltage range is required.

Derivation of PSE and PD PI R_{max} , R_{min} Equation limits that meets system worst case End to End Pair To pair effective resistance unbalance. Yair Darshan, June 2015 Rev 013a.

Derivation of PSE PI Requirements

The following is the End to End Pair to Pair Resistance Unbalance (E2E_P2PRunb or “ α ”) equation for a system including PSE, PD and Channel (cables and connectors).

$$(1) \quad \alpha = E2E_P2PRunb = \frac{\left(\sum R_{max}^{PSE} - \sum R_{min}^{PSE}\right) + \left(\sum R_{max}^{PD} - \sum R_{min}^{PD}\right) + \left(\sum R_{max}^{CH} - \sum R_{min}^{CH}\right)}{\left(\sum R_{max}^{PSE} + \sum R_{min}^{PSE}\right) + \left(\sum R_{max}^{PD} + \sum R_{min}^{PD}\right) + \left(\sum R_{min}^{CH} + \sum R_{max}^{CH}\right)}$$

All resistance values are effective resistances which mean that the values include the effects of non-linear components at their operating point and the effects of Pair to pair voltage differences both in the PSE and PD.

(2) The PSE PI P2PRUNB is:

$$PSE_P2PRunb = \frac{\left(\sum R_{max}^{PSE} - \sum R_{min}^{PSE}\right)}{\left(\sum R_{max}^{PSE} + \sum R_{min}^{PSE}\right)}$$

(3) The PSE PI P2PRUNB contribution to the E2E_P2PRunb of the system is

$$PSE_P2PRUNB_contribution = \frac{\left(\sum R_{max}^{PSE} - \sum R_{min}^{PSE}\right)}{\left(\sum R_{max}^{PSE} + \sum R_{min}^{PSE}\right) + \left(\sum R_{max}^{PD} + \sum R_{min}^{PD}\right) + \left(\sum R_{min}^{CH} + \sum R_{max}^{CH}\right)}$$

We can see that PSE contribution (3) is not equal to PSE PI P2PRUNB (2).

As a result we need to transform PSE_P2PRUNB (2) to PSE_P2PRUNB_contribution (3) in order to have the correct weight of the PSE in the whole system defined by (1) i.e. to find the function F_x that satisfies the worst case E2E_P2PRunb at the maximum PSE Type operating power (which is not necessarily the point of maximum pair current).

$$\frac{\left(\sum R_{max}^{PSE} - \sum R_{min}^{PSE}\right)}{\left(\sum R_{max}^{PSE} + \sum R_{min}^{PSE}\right)} \cdot F_x = \frac{\left(\sum R_{max}^{PSE} - \sum R_{min}^{PSE}\right)}{\left(\sum R_{max}^{PSE} + \sum R_{min}^{PSE}\right) + \left(\sum R_{max}^{PD} + \sum R_{min}^{PD}\right) + \left(\sum R_{min}^{CH} + \sum R_{max}^{CH}\right)}$$

This step will in turn provide the equation that defines the relationship between RPSEmin and RPSEmax in terms of effective resistance values. e.g. if Rmin is selected by the designer, then the corresponding maximum allowable value of Rmax that will not exceed the E2E_P2PRunb limit will be provided (Just specifying Rmax/Rmin ratio will not work for our objective above).

There are few ways to do this task. The following is a simple analytical transformation process:

Derivation of PSE and PD PI Rmax, Rmin Equation limits that meets system worst case End to End Pair To pair effective resistance unbalance. Yair Darshan, June 2015 Rev 013a.

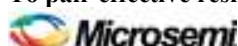

Describing (1) as a system that includes all parts:

$$(4) \quad E2EP2PRunb = \frac{\left(\sum R_{max} - \sum R_{min}\right)}{\left(\sum R_{max} + \sum R_{min}\right)} = \alpha$$

Opening and solving for Rmax/Rmin in terms of α .

$$(5) \quad \begin{aligned} \left(\sum R_{max} - \sum R_{min}\right) &= \alpha \cdot \left(\sum R_{max} + \sum R_{min}\right) \\ \sum R_{max} - \sum R_{min} &= \alpha \cdot \sum R_{max} + \alpha \cdot \sum R_{min} \\ \sum R_{max} - \alpha \cdot \sum R_{max} &= +\alpha \cdot \sum R_{min} + \sum R_{min} \\ (1 - \alpha) \cdot \sum R_{max} &= (1 + \alpha) \cdot \sum R_{min} \\ \frac{\sum R_{max}}{\sum R_{min}} &= \frac{(1 + \alpha)}{(1 - \alpha)} = u \end{aligned}$$

As a result from (5):

$$(6) \quad \begin{aligned} \frac{\sum R_{max}}{\sum R_{min}} &= u \\ u \cdot \sum R_{min} - \sum R_{max} &= 0 \end{aligned}$$

The E2E_P2PRunb equation from (1) or its simpler form (4) can be expressed in the following form:

$$(7) \quad U \cdot \sum R_{min} - \sum R_{max} = 0, \quad \text{Where } U = \frac{1 + \alpha}{1 - \alpha}$$

Separating the contributors PSE, PD and Channel results in:

$$(8) \quad \begin{aligned} (U \cdot R_{PSEmin} - R_{PSEmax}) + (U \cdot R_{CHmin} - R_{CHmax}) + (U \cdot R_{PDmin} - R_{PDmax}) \\ = Cont_{PSE} + Cont_{CH} + Cont_{PD} = 0 \end{aligned}$$

Derivation of PSE and PD PI Rmax, Rmin Equation limits that meets system worst case End to End Pair To pair effective resistance unbalance. Yair Darshan, June 2015 Rev 013a.

Each contributor is a constant in the worst case model:

$$Cont_PSE + Cont_CH + Cont_PD = 0$$

And a contributor can be solved independently to meet an E2ERunb limit, given the worst case scenario:

(10)

$$(U \cdot R_{PSEmin} - R_{PSEmax}) + (U \cdot R_{CHmin} - R_{CHmax}) + (U \cdot R_{PDmin} - R_{PDmax}) = Cont_pse + Cont_CH + Cont_PD = 0$$

$$(11) \quad (U \cdot R_{PSEmin} - R_{PSEmax}) + Cont_CH + Cont_PD = 0$$

Simplifying further by combining the constants:

$$K_{pse} = Cont_CH + Cont_PD$$

$$(12) \quad (U \cdot R_{PSEmin} - R_{PSEmax}) + K_{pse} = 0$$

Solving for Rmax expressed as a range with a worst case limit results in:

$$(13) \quad R_{PSEmax} \leq U \cdot R_{PSEmin} + K_{PSE}$$

Where:

U is a constant determined by the target end to end pair to pair resistance/current unbalance.
 K_{PSE} is a constant derived for the PD and Channel contribution to the worst case E2ERunb.
 R_{PSEmin} and R_{PSEmax} are the effective PSE PI resistances.

In order to simplify PSE PI specification and make it practical for the design phase, it is possible to specify R_{PSEmin} and R_{PSEmax} in terms of nominal component resistance values and specifying PSE pair to pair voltage difference as two separate parameters which is equivalent to specifying the effective values of R_{PSEmin} , R_{PSEmax} as currently presented by Equation 13. (K_{PSE} is specified with PD diode pair to pair voltage differences so it stays with effective resistance value) Due to the fact that PSE_Vdiff is very small (2mV currently in the specification), the effective values of R_{PSEmin} and R_{PSEmax} are similar to the nominal components values of R_{PSEmin} and R_{PSEmax} with some negligible error.

[See Example next page.](#)

Derivation of PSE and PD PI Rmax, Rmin Equation limits that meets system worst case End to End Pair To pair effective resistance unbalance. Yair Darshan, June 2015 Rev 013a.

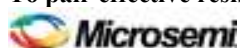

Example Usage for PSE PI P2P_unb specifications

Assuming that the following represents a system that is considered to be a worst case system in terms of the components it uses, operation at maximum operating power, and at the practical shortest channel length[m] (i.e. the minimum Channel Rmax, Rmin.). The Rpair values below are the nominal resistances. Effective resistances, which include the Vdiff parameter effects, are determined in a simulation.

1. PSE has PSE_Vdiff=2mV as specified in Table 33-11 item 1a in 802.3bt Draft D0.4 and PD Vdiff=58mV. In order to derive PSE specification components in terms of nominal Rmax and Rmin at PSE side and effective Rmax and Rmin at PD side ,the simulation was set with PSE Vdiff=0mV and PD Vdiff=60mV so total 60mV system Vdiff is maintained. This procedure will require specifying PSE Vdiff at no load condition.
2. PD: Rpair_max_{pd} = 0.09 Rpair_min_{pd} = 0.075
3. Channel : Rpair_max_{ch} = 0.1005 Rpair_min_{ch} = 0.0909
4. PSE: Rpair_max_{pse} = 0.091 Rpair_min_{pse} = 0.076
5. Channel length =2.65m , Rch_max=0.1Ω Rch_min=0.0857Ω
6. PD_Vdiff=60mV

For Type 3, PD input power=51W, The Ch + PD effective resistance:

$$R_{pair_max_{ch+pd}} = 1.249 \quad R_{pair_min_{ch+pd}} = 0.6324$$

Initial Determination of E2ERunb and Kpse using worst case values of example system:

$$\frac{\sum R_{max} - \sum R_{min}}{\sum R_{max} + \sum R_{min}} = E2ER_{unb} = 0.3086$$

Derive PSE Specification:

$$U = \frac{1 + E2ER_{unb}}{1 - E2ER_{unb}} = 1.893.$$

$$K_{pse} = [R_{pair_min_{ch+pd}} * U - R_{pair_max_{ch+pd}}] = 0.6324 * 1.893 - 1.249 = -0.053$$

Specification becomes:

$$R_{pair_max_{pse}} = 1.893 * R_{pair_min_{pse}} - 0.053.$$

Cross-Check:

Arbitrary PSE Rpair_min = 0.2

PSE Rpair_max limit Calculated with above equation: Rpair_max_{pse} = 1.893 * 0.2 - 0.053 = 0.3256
(The above values of PSE Rpairmax and Rpair min should meet the E2ERunb limit with the worst case ch+pd values represented by U and Kpse above):

Any PSE that uses Rpair_max_{pse} ≤ 0.325 and Rpair_min_{pse} = 0.2

With the worst case load: Rpair_max_{ch+pd} = 1.249 and Rpair_min_{ch+pd} = 0.6324,
will meet the E2ERunb Limit:

E2ERunb = (Rmax-Rmin)/(Rmax+Rmin)=

$$[(0.3256 + 1.249) - (0.2 + 0.6324)] / [(0.3256 + 1.249) + (0.2 + 0.6324)] = 0.3089$$

Derivation of PSE and PD PI Rmax, Rmin Equation limits that meets system worst case End to End Pair To pair effective resistance unbalance. Yair Darshan, June 2015 Rev 013a.

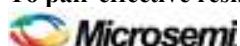

For Type 4, PD input power=71.3W, The Ch + PD effective resistance:

$$R_{\text{pair_max}_{\text{ch+pd}}} = 0.975 \quad R_{\text{pair_min}_{\text{ch+pd}}} = 0.529$$

Initial Determination of E2ERunb and Kpse using worst case values of example system:

$$\frac{\sum R_{\text{max}} - \sum R_{\text{min}}}{\sum R_{\text{max}} + \sum R_{\text{min}}} = E2ER_{\text{unb}} = 0.275$$

Derive PSE Specification:

$$U = \frac{1 + E2ER_{\text{unb}}}{1 - E2ER_{\text{unb}}} = 1.76$$

$$K_{\text{pse}} = [R_{\text{pair_min}_{\text{ch+pd}}} * U - R_{\text{pair_max}_{\text{ch+pd}}}] = 0.529 * 1.76 - 0.975 = -0.043$$

Specification becomes:

$$R_{\text{pair_max}_{\text{pse}}} = 1.76 * R_{\text{pair_min}_{\text{pse}}} - 0.043.$$

Cross-Check:

Arbitrary PSE $R_{\text{pair_min}} = 0.2$

PSE $R_{\text{pair_max}}$ limit Calculated with above equation: $R_{\text{pair_max}_{\text{pse}}} = 1.76 * 0.2 - 0.043 = 0.309$
 (The above values of PSE $R_{\text{pair_max}}$ and $R_{\text{pair_min}}$ should meet the E2ERunb limit with the worst case ch+pd values represented by U and Kpse above):

Any PSE that uses $R_{\text{pair_max}_{\text{pse}}} \leq 0.325$ and $R_{\text{pair_min}_{\text{pse}}} = 0.2$

With the worst case load: $R_{\text{pair_max}_{\text{ch+pd}}} = 0.975$ and $R_{\text{pair_min}_{\text{ch+pd}}} = 0.529$, will meet the E2ERunb Limit: $E2ER_{\text{unb}} = (R_{\text{max}} - R_{\text{min}}) / (R_{\text{max}} + R_{\text{min}}) =$

$$[(0.975 + 0.309) - (0.529 + 0.2)] / [(0.975 + 0.309) + (0.529 + 0.2)] = 0.2757$$

Derivation of PSE and PD PI Rmax, Rmin Equation limits that meets system worst case End to End Pair To pair effective resistance unbalance. Yair Darshan, June 2015 Rev 013a.

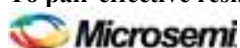
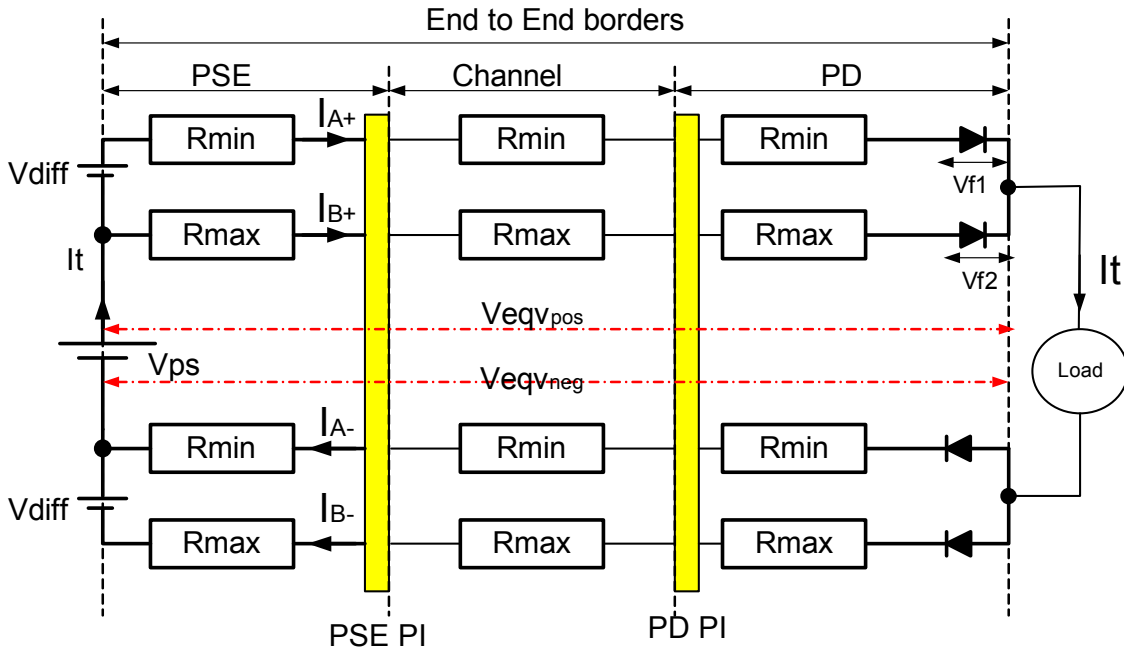

Figure 1



$$E2EP2P_Iunb = \frac{IA^+ - IB^+}{IA^+ + IB^+} = \frac{\left(\frac{Veqv_pos}{IA^+}\right) - \left(\frac{Veqv_pos}{IB^+}\right)}{\left(\frac{Veqv_pos}{IA^+}\right) + \left(\frac{Veqv_pos}{IB^+}\right)} = \frac{\sum Rmin_eqv - \sum Rmax_eqv}{\sum Rmin_eqv + \sum Rmax_eqv} = E2EP2P_Runb$$

- This is a worst case model. All contributors of voltage and resistance are set to maximize the current on Pair A+ and minimize the current on pair B+. Same applies for the negative pairs. Example: Vf1<Vf2. Vdiff at positive side is in positive polarity in relation to Vps positive feeding point.
 - The same equation applies for the negative pairs.
 - PD Vdiff is Vf1-Vf2 in this example.
 - PSE Vdiff is the pair to pair voltage difference measured at the PSE PI at no load conditions.
 - If Vdiff=0 and Vf1=Vf2, then components nominal static value are equal to their effective value.

Derivation of PSE and PD PI Rmax, Rmin Equation limits that meets system worst case End to End Pair To pair effective resistance unbalance. Yair Darshan, June 2015 Rev 013a.



Annex A – Additional Research conclusions.

Effective resistance:

The effective resistance of a pair from end to end (see figure 1) is function of the actual pair to pair current unbalance.

The pair to pair current unbalance is a function the component's pair to pair resistance differences and the pair to pair voltage differences in the PSE and voltage drop differences at the PD.

As such effective resistance is a dependent variable unlike the resistance of a resistive element that is a fixed value and is independent variable.

The effective resistance is measured by using V_{eq_xxx} divided by the pair current. V_{eq_xxx} includes all unbalance sources and is described by Figure 1.

Kpse and Kpd

For compliance tests of PSE or PD, the test setup has to include fixed values of the components of Kpse and Kpd. The components of Kpse and Kpd are described by the specification derivation calculation examples in this document.

Worst case analysis

The specification equations were derived based on the positive pairs because they are subject to a higher worst case E2EP2P_lunb and/or maximum pair current than the negative pairs. This is due to a lower total resistance in the PSE positive pairs and the fact that the additional PSE PI resistance on the negative pairs (Rsense and RDSON) improves E2EP2P_lunb.

Components values are based on ad-hoc database. See reference 5.

PSE Vdiff vs PD Vdiff

1. Total budget for PSE Vdiff and PD Vdif is 60mV. This number was derived in reference 8.
2. The PD vdiff gets most of the Vdiff budget in order to allow low cost diode bridges in the PD.
3. Typical 4P PSE is using common power supply and only resistive elements in the PSE PI that results with very low Vdiff <1mV when common power supply practice design rules are used in order to reduce PCB trace resistance or connecting wires whenever high current is flowing through it.
4. Currently in IEEE802.3bt Draft 0.4, the PSE Vdiff is set to 2mV max. As a result, PD Vdiff=58mV.
5. It is important to emphasis that moving 60mV total Vdiff to PSE and having Zero Vdiff at PD will result with lower E2EP2PRunb (~22% in Type 3) than if 60mV will be in the PD and 0mV at the PSE (~30% in Type 3). This is due to the nonlinear nature of the diodes that the diode forward voltage difference affects the current unbalance and the value of the current affect the effective resistance. At low voltage difference at PSE i.e. PSE Vdiff=2mV and PD Vdiff=58mV, if PSE Vdiff=0mV and PD Vdiff=60mV, almost the same E2EP2P_lunb results will be obtained. This fact, help us during simulation, to set PSE Vdiff=2mV and PD Vdiff=60mV to get specification numbers for PSE side in nominal component values and at PD side with effective values.
6. Increase of PSE Vdiff from 0 to 2mV (PD Vdiff=60mV) increases pair maximum current by ~2mA and E2EP2P_lunb by 0.62%.

Derivation of PSE and PD PI Rmax, Rmin Equation limits that meets system worst case End to End Pair To pair effective resistance unbalance. Yair Darshan, June 2015 Rev 013a.

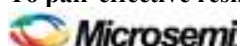

7. In the general case the following of how to run the simulations to find the correct constants the following rules should be applied:

Simulation conditions in order to find the correct constants:

For derivation the PSE PI equation constant we will run the simulation with PSE $V_{diff}=0$ and PD $V_{diff}=60mV$. The reason is that for PSE V_{diff} we want to specify the nominal R_{max} and R_{min} with open load V_{diff} as it is easier process to PSE designers. In order to include the PSE V_{diff} effect on P2P unbalance, we move the PSE V_{diff} value (2mV) to the PD V_{diff} budget so total V_{diff} stays 60mV.

For derivation of PD PI equations we need the PSE + CH effective resistance so we can use it later in the PD test set up and it should include the PSE V_{diff} effect since in the test setup it will be hard to generate 2mV V_{diff} on PSE voltage source so the 2mv effect will be converted to new effective resistance of PSE + CH R_{max} , R_{min} and PD V_{diff} will be set to 58mV.

Annex B Derivation of PSE Rmax, Rmin equation for PSE PI test setup

Step 1: Derivation of PSE Rmax, Rmin Equation

$$(U \cdot R_{PSEmin} - R_{PSEmax}) + (U \cdot R_{CHmin} - R_{CHmax}) + (U \cdot R_{PDmin} - R_{PDmax}) = 0$$

$$(U \cdot R_{PSEmin} - R_{PSEmax}) + U \cdot (R_{CHmin} + R_{PDmin}) - (R_{CHmax} + R_{PDmax}) = 0$$

$$R_{PSEmax} \leq (U \cdot R_{PSEmin}) + U \cdot (R_{CHmin} + R_{PDmin}) - (R_{CHmax} + R_{PDmax})$$

$$R_{PSEmax} \leq (U \cdot R_{PSEmin}) + K_{pse}$$

$$K_{pse} = U \cdot (R_{CHmin} + R_{PDmin}) - (R_{CHmax} + R_{PDmax})$$

Step 2: Derivation of PD Load and Channel Equation

$$(U \cdot R_{PSEmin} - R_{PSEmax}) + (U \cdot R_{CHmin} - R_{CHmax}) + (U \cdot R_{PDmin} - R_{PDmax}) = 0$$

$$(U \cdot R_{PSEmin} - R_{PSEmax}) + U \cdot (R_{CHmin} + R_{PDmin}) - (R_{CHmax} + R_{PDmax}) = 0$$

$$(R_{CHmax} + R_{PDmax}) = U \cdot (R_{CHmin} + R_{PDmin}) + (U \cdot R_{PSEmin} - R_{PSEmax})$$

$$R_{LOADmax} = U \cdot (R_{LOADmin}) + (U \cdot R_{PSEmin} - R_{PSEmax})$$

$$R_{LOADmax} = U \cdot (R_{LOADmin}) + (U \cdot R_{PSEmin} - R_{PSEmax})$$

$$R_{LOADmax} = U \cdot (R_{LOADmin}) + C_{PSE}$$

$$C_{PSE} = (U \cdot R_{PSEmin} - R_{PSEmax})$$

Derivation of PSE and PD PI Rmax, Rmin Equation limits that meets system worst case End to End Pair To pair effective resistance unbalance. Yair Darshan, June 2015 Rev 013a.

References

Reference #	Subject	Link/Source
1	Channel Length, L.	ANSI/TIA-568-C.2
	Cable Runb	
	Number of connector	
	Connector resistance, Rconn_max	
2	Cable P2PRUNB	http://www.ieee802.org/3/4PPOE/public/nov13/darshan_01_1113.pdf
3	Channel P2PRUNB	802.3bt D0.2. annex 33A.3
4		http://www.ieee802.org/3/bt/public/sep14/darshan_05_0914_rev_7a.pdf
5	System Unbalance Adhoc material	Table G1 pages 34,35 at: http://www.ieee802.org/3/bt/public/mar15/darshan_02_0315.pdf
	System Unbalance Calculations	
	Cordage Resistivity (wire)	
	Cable Resistivity (wire)	
	Number of connector	
	Connector resistance, Rconn.	
6	Rdson	http://www.ieee802.org/3/bt/public/jan15/darshan_01_0115.pdf
7	PSE Vdiff	http://www.ieee802.org/3/bt/public/jan15/darshan_03_0115.pdf
8	PD Vdiff	http://www.ieee802.org/3/bt/public/mar15/darshan_03_0315.pdf
9	PD Load power	http://www.ieee802.org/3/bt/public/mar15/darshan_01_0315.pdf
10	System Unbalance simulations	http://www.ieee802.org/3/bt/public/may14/beia_1_0514.pdf
		http://www.ieee802.org/3/bt/public/mar15/darshan_02_0315.pdf
11	System Unbalance calculations	http://www.ieee802.org/3/bt/public/sep14/index.html by Ken Bennett
12	PSE PI requirements	http://www.ieee802.org/3/bt/public/mar15/darshan_08_0315.pdf

Derivation of PSE and PD PI Rmax, Rmin Equation limits that meets system worst case End to End Pair To pair effective resistance unbalance. Yair Darshan, June 2015 Rev 013a.

