



PMA control state machines for GEPOF

Rubén Pérez-Aranda
(rubenpda@kdpof.com)

Agenda



- Analysis of PHD reliability
- PHY control state diagrams
- Adaptive THP protocol and state diagrams
- PHY quality monitor



Analysis of PHD reliability

Analysis of PHD reliability



- In [2], the FEC and modulation used to transmit PHD information were defined. They were conceived to provide a very robust communication side-channel suitable for PHY control and management.
- PHY state machines that involve both link partners will use the PHD to exchange reliable information for coordination
- Here is demonstrated the reliability of PHD in terms of MTBE; let's start with the channel scenario where gigabit link can be established
- As it was demonstrated in [4], the min SNR required by coded 16-PAM scheme in detector for 1Gbps link providing a BER $< 10^{-12}$ is 25.01 dB, assuming THP is used for channel equalization:
 - THP precoding loss: $10 \cdot \log_{10}(M^2/(M^2 - 1)) = 0.017$ dB, for $M = 16$. See [5].
 - Crest factor: $10 \cdot \log_{10}(3) = 4.78$ dB. See [5].
 - The effective SNR of the channel is obtained in detector after feedforward equalization for 16-PAM symbols. See [5].
- By simulation, we know that for the worst case ISI channel, the max number of compensation levels needed by THP is $V_{\text{THP}} = 5$, which is equivalent to the modulo constellation expansion experienced by the TH precoded signal at the output of channel

Analysis of PHD reliability



- The PHS is transmitted using 2-PAM 1 dimension modulation, built from a 2 dimensional mapping, and scaled to use full OMA of light emitter therefore, crest-factor is 0 dB
- On the other hand, the PHS is not TH precoded and equalization is intended to be fully implemented by the link partner in the PMA receive function, therefore:
 - The PHS parts of the transmission block does not experience amplitude expansion, being its SNR decreased by V_{THP} factor, assumed the worst case scenario such that the noise is added just in the channel output after ISI; this is pessimistic, but it lets us to determine a lower bound for reliability of PHD transmission
 - No precoding loss is experienced
- Let us assume the receiver implements optimal VA-MLSE [6] to estimate the sequence of PHS symbols after feedforward equalization (pre-cursor equalization and noise whitening), therefore, the effective SNR of channel is achieved for PHS decoding. After MLSE, Berlekamp algorithm is used for BCH decoding
 - VA-MLSE is recommended versus DFE for PHS equalization to avoid undesired error propagation effects through the feedback filter
 - The present reliability analysis is not necessarily true if DFE is used
 - Special 2D mapping defined in [2] is intended to allow low cost VA-MLSE implementation for PHS equalization

Analysis of PHD reliability

- Let's calculate the normalized SNR of operation for PHS decoding:

$$SNR_{norm}^{PHS} = SNR_{min}^{16PAM} + 10 \log_{10}(3) + 10 \log_{10}\left(\frac{16^2}{16^2 - 1}\right) + 20 \log_{10}\left(\frac{1}{V_{THP}}\right) - 10 \log_{10}(2^{2\eta} - 1)$$

$$SNR_{norm}^{PHS} = 25.01 + 4.77 + 0.017 - 13.98 + 1.28 = 17.09 \text{ dB}$$

- Where the spectral efficiency per dimension is:

$$\eta = \frac{1}{2} \frac{k_{BCH}}{n_{BCH}} = 0.5 \frac{720}{896} = 0.4017 \text{ b/s/Hz/dim}$$

- Under this condition, the BER at the output of VA-MLSE equalizer is:

$$BER_{VA-MLSE} = 1.18 \cdot 10^{-18}$$

- The probability of BCH codeword error after Berlekamp decoding will be:

$$Pe_{BCH-CW} = 5.9 \cdot 10^{-270}$$

- And the time required per PHD codeword is (see [2]):

$$T_{PHD} = \frac{28(7904 + 128 + 2 \cdot 16)}{325 \cdot 10^6} \text{ s} = 697.4 \text{ } \mu\text{s}$$

Analysis of PHD reliability



- Then, the MTBE shall be given by:

$$MTBE = \frac{T_{PHD}}{Pe_{BCH-CW}} = 3.7 \cdot 10^{258} \text{ years}$$

- We can consider the PHD transmission will never fail, therefore the protocols designed to be supported on that for coordination between link partners can be really simplified
- Let's provide an idea about the margin of operation of PHD transmission versus payload coded 16-PAM:
 - Let's consider the SNR for 16-PAM decoding is decreased 10 dB below the minimum required for 1 Gbps, that is, the SNR in detector is 15 dB
 - Under this situation, Gigabit link is not possible; $BER_{16-PAM} \sim 0.5$
 - However, the PHD transmission under this condition operates with a probability of codeword error of $2 \cdot 10^{-9}$, equivalent to MTBE of 4 days.
 - Therefore, we can consider the OAM channel implemented over PHD will be always reliable for management entities with a margin of ~ 10 dB below the needed SNR for Gigabit link. That is really interesting for diagnosis and test in automotive environment. See [7] for details on OMA.



PHY control state diagrams

PHY RX control FSM

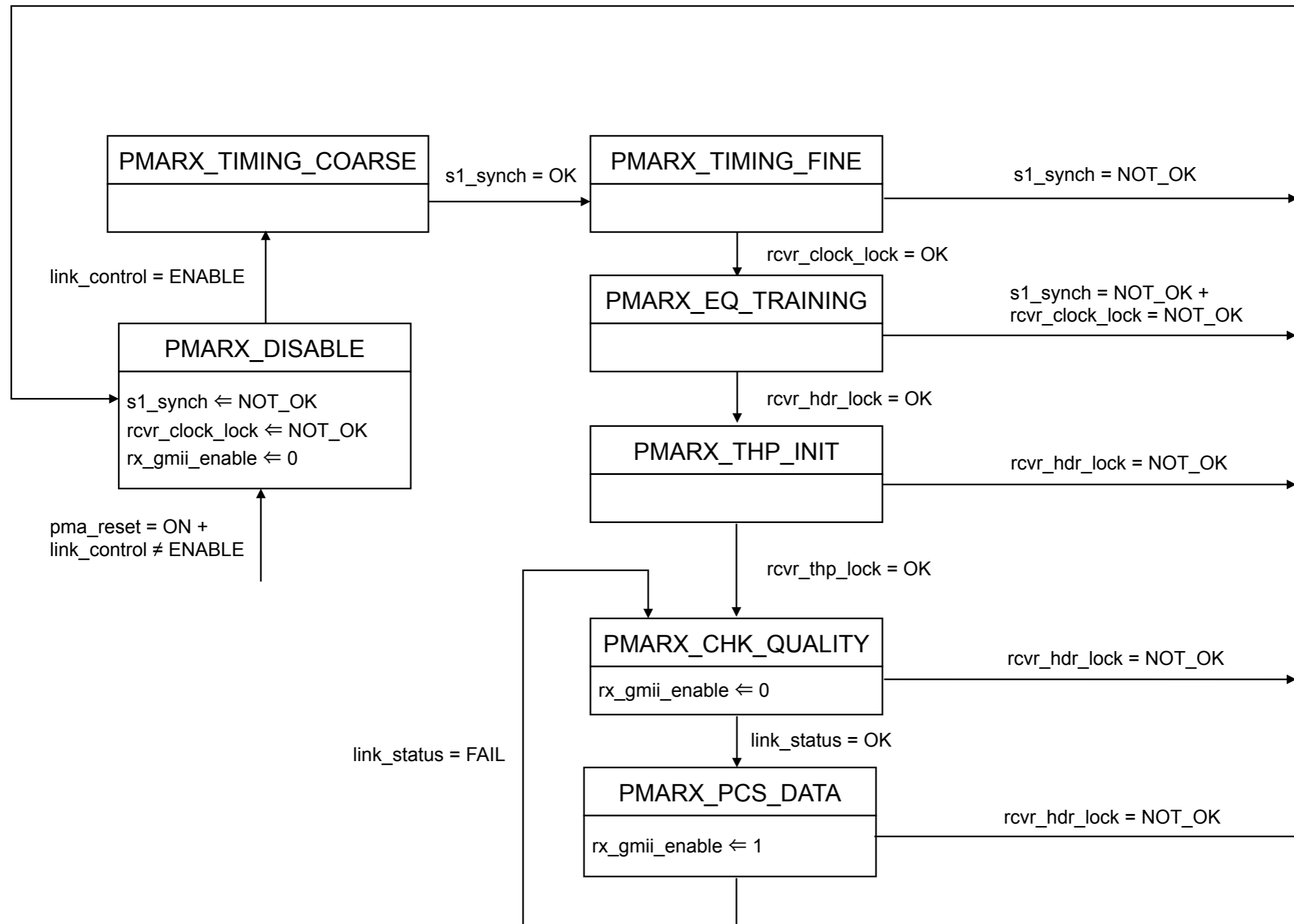

PHY TX control FSM

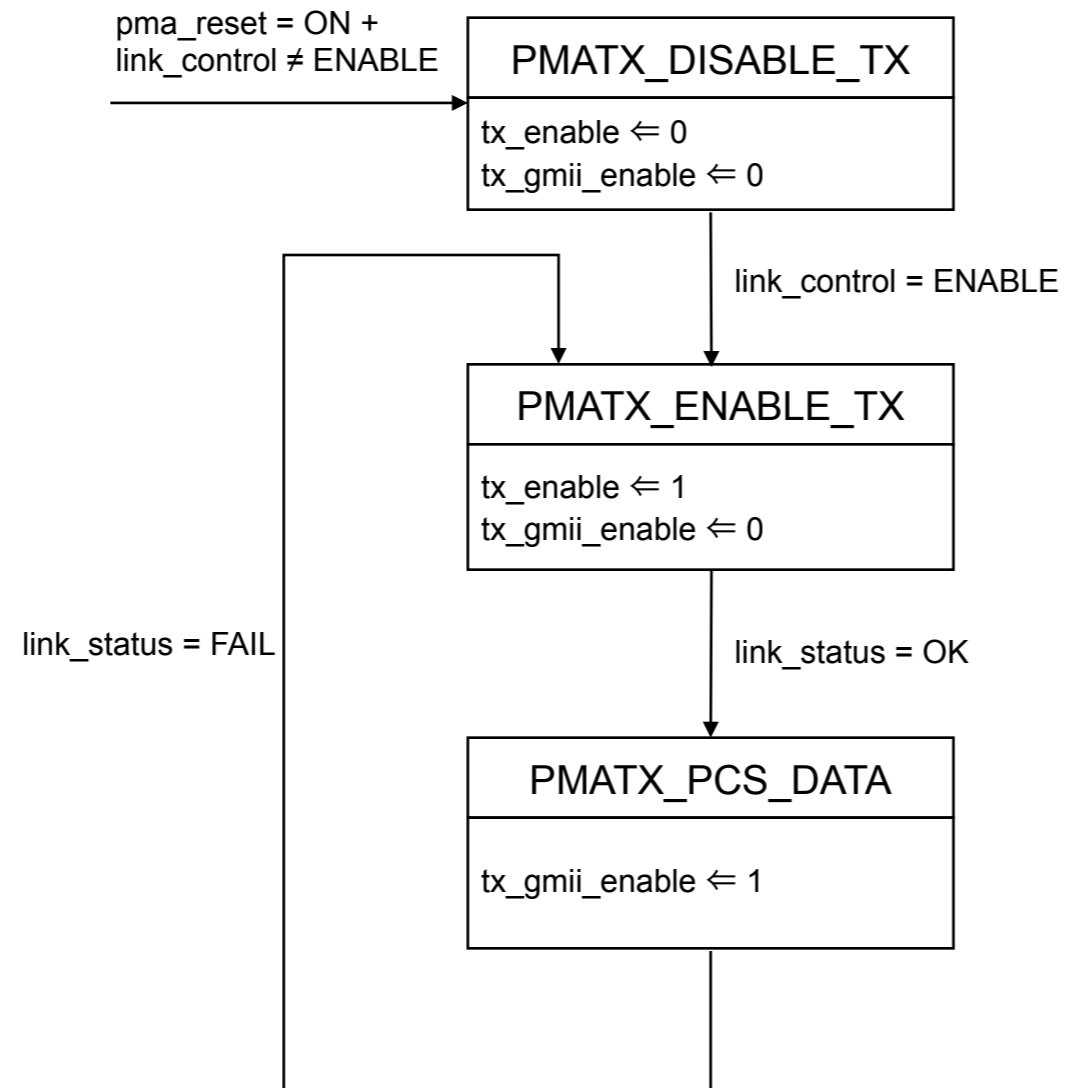

Link monitor FSM

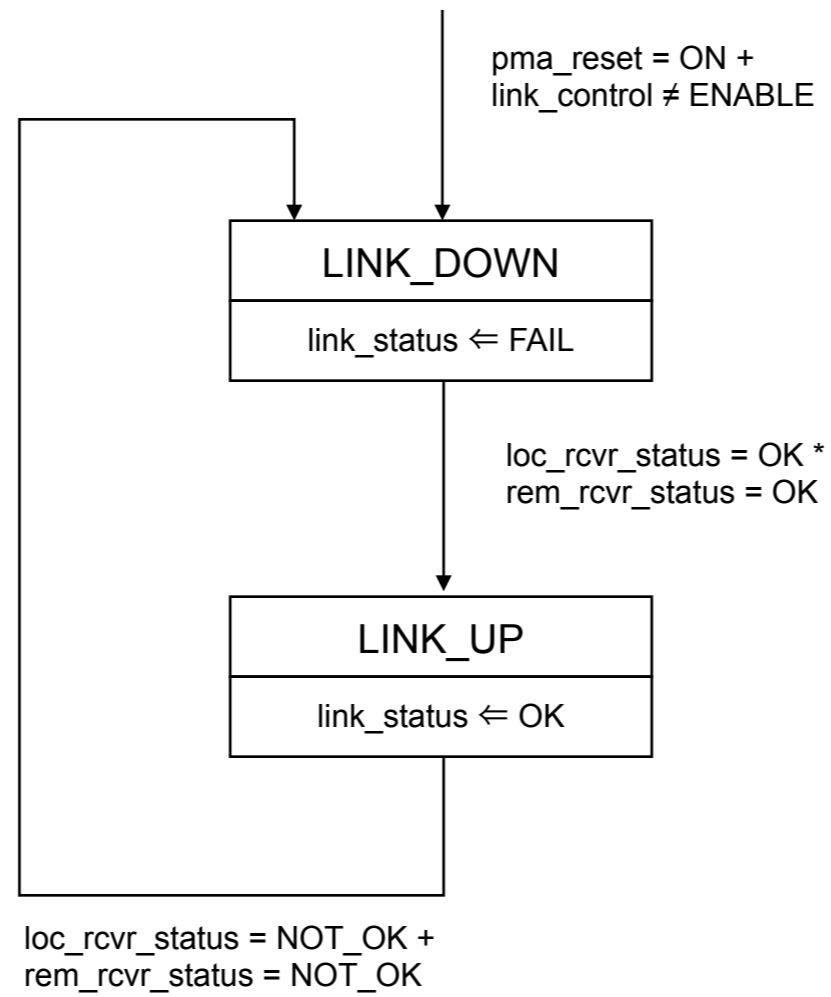

PHD monitor FSMs

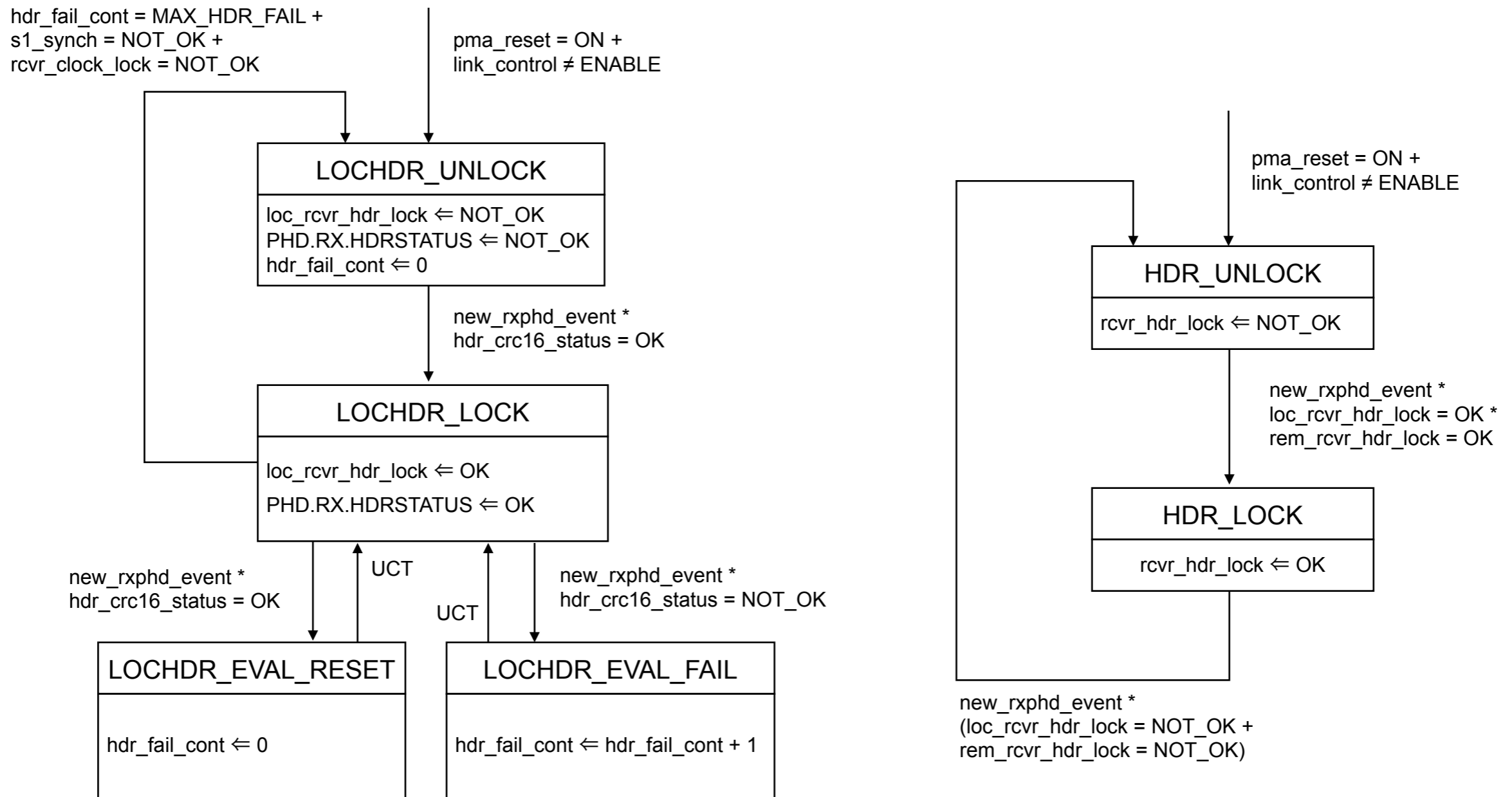

MAX_HDR_FAIL:
 maximum acceptable
 contiguous erroneous PHD receptions.

MAX_HDR_FAIL = 2

PHY control - variables



- **pma_reset**: allows reset of all the PMA functions. It is set by the PMA reset. PMA reset function is intended to be executed whenever one of power on or reset from management entity conditions occur. All state diagrams take the open-ended pma_reset branch upon execution of PMA Reset.
 - ON: reset is asserted
 - OFF: reset de-asserted
- **link_control**: controls the connection of PMA to the PMD. This control variable is foreseen for an eventual coexistence of the PHY with an autonegotiation sub-system.
 - DISABLE: isolates the PMA from the PMD
 - ENABLE: connects the PMA to the PMD (both transmitter and receiver)
- **s1_synch**: variable set by the PMA Clock Recovery function to indicate the synchronization of transmission scheme has been achieved, so that the PHY is able to recognize the start of the transmission block.
 - OK: synchronization based on S1 pilot signal has been achieved.
 - NOT_OK: synchronization has not been achieved.
- **rcvr_clock_lock**: variable set by the PMA Clock Recovery function to indicate that the clock has been properly recovered from the receive signal.
 - OK: clock is stable and optimum phase is provided for sampling receive signal.
 - NOT_OK: clock has not been recovered from receive signal and/or it is not stable.
- **loc_rcvr_status**: variable set by the PMA Receive function to indicate the correct or incorrect operation of the receive link for the local PHY.
 - OK: the receive link for the local PHY is operating reliably.
 - NOT_OK: operation of the receive link for the local PHY is unreliable.

PHY control - variables



- **rem_rcvr_status**: variable set by the PCS Receive function to indicate whether correct operation of the receive link for the remote PHY is detected or not (received in PHD.RX.LINKSTATUS, see [3])
 - OK: the receive link for the remote PHY is operating reliably.
 - NOT_OK: operation of the receive link for the remote PHY is unreliable.
- **link_status**: variable that is set by the PMA Link Monitor and passed to the PCS via the PMA_LINK.indication primitive
 - OK: the link has been established between link partners guaranteeing data reliability in both communication directions
 - FAIL: no link is not established (one or both directions are not providing reliability)
- **loc_rcvr_hdr_lock**: variable set by the PMA Receive function to indicate whether correct reception of PHD is detected for the local PHY
 - OK: PHD reception is reliable for the local PHY.
 - NOT_OK: PHD reception is unreliable for the local PHY.
- **rem_rcvr_hdr_lock**: variable set by the PMA Receive function to indicate whether correct reception of PHD is detected for the remote PHY (received in PHD.RX.HDRSTATUS, see [3])
 - OK: PHD reception is reliable for the remote PHY.
 - NOT_OK: PHD reception is unreliable for the remote PHY.
- **rcvr_hdr_lock**: variable set by the PMA Receive function to indicate whether reliable transmission and reception of PHD are detected
 - OK: PHD transmission and reception are reliable.
 - NOT_OK: PHD transmission or reception are unreliable.
- **new_rxphd_event**: variable set by the PCS receive function to indicate the arriving of a new correct (i.e. CRC16 is OK) PHD block received from the link partner
 - 1: indicates the event of a new PHD received from link partner. The value 1 extends one receive symbol period
 - 0: indicates no new PHD was received

PHY control - variables



- **rcvr_thp_lock**: variable set by the PMA Phy Control function to indicate whether the Tomlinson-Harashima precoding is initialized, therefore the PMA Receive function is receiving payload data sub-blocks TH precoded with the coefficients that were requested by the PMA Phy Control.
 - OK: THP is initialized; data payload is received TH precoded.
 - NOT_OK: THP is not initialized.
- **rx_gmii_enable**: variable set by the PMA Phy Control function to enable or disable the 64B/65B PCS decoder in charge to map the received PDBs into GMII RX; this function is only enabled when bidirectional link is established
 - 1: PCS decoder to GMII RX is enabled
 - 0: PCS decoder to GMII RX is disable
- **tx_gmii_enable**: variable set by the PMA Phy Control function to enable or disable the 64B/65B PCS encoder in charge to map the GMII TX into PDBs; this function is only enabled when bidirectional link is established
 - 1: PCS encoder from GMII TX is enabled
 - 0: PCS encoder from GMII TX is disable
- **tx_enable**: controls the transmit signal generation
 - 1: PMA and PCS transmit functions are enabled; the PMA TX shall control PMD TX as a function of the operation mode (i.e. normal idle, or LPI)
 - 0: PMA and PCS transmit functions are disabled; the PMA shall instruct to PMD TX to disable the optical power transmission
- **hdr_crc16_status**: result of the CRC16 evaluation for a received PHD from the link partner; this variable is assigned for each received PHD block. As a function of this variable, a `new_rxphd_event` will be generated.
 - OK: the received PHD block is correct by CRC16 verification
 - NOT_OK: the received PHD block is not correct determined by CRC16 verification
- **hdr_fail_cont**: variable used as counter of the reception of contiguous erroneous PHD blocks.



Adaptive THP protocol and state diagrams

Adaptive THP - general architecture



- Feedback filter (FBF) is implemented at TX to eliminate the channel post-cursor
- Feedforward filter (FFF) is implemented at RX to compensate both the pre-cursor and cursor of channel and to provide white noise for the 16-PAM symbols detection
- For correct operation of THP, it is required synchronization (i.e. matching) between the set of coefficients employed at the transmitter and the receiver
- The receiver, by implementation of the adaptive filtering algorithm (e.g. RLS, LMS), will estimate simultaneously:
 - Feed-Forward Filter (FFF) to be used at the receiver
 - Feed-Back Filter (FBF) to be used for precoding at the transmitter
- No partial adaptation of feedforward filter with fixed THP feedback is considered, to avoid performance penalties and because the transmission scheme proposed in [2] allows simultaneous FBF and FFF adaptation

Adaptive THP - general architecture



- Then, the receiver, by implementing the adaptive filtering data-aided algorithm by using S2 pilots estimates simultaneously FFF and FBF filters, which are matched
- The receiver makes a request to the transmitter for using a set of coefficients at FBF; this set is identified by a `PHD.RX.REQ.TH.P.SETID > 0`. The set of FBF coefficients are sent to the link partner by using `PHD.RX.REQ.TH.P.COEF` field
- The receiver saves the FBF and FFF corresponding to this SETID, to be used:
 - For PHS equalization based on VA MLSE
 - For feedforward filtering of payload coded 16-PAM symbols when the transmitter has announced in the previous transmit block that the THP will be enabled and identifying the set of coefficients with `PHD.TX.NEXT.TH.P.SETID > 0`
- The receiver waits for the transmitter uses the requested set of FBF coefficients in THP to make a new request
- The protocol is very simple, based on the demonstrated reliability of PHD transmission; formal definition is provided in form of finite state machines

Adaptive THP - THP TX FSM

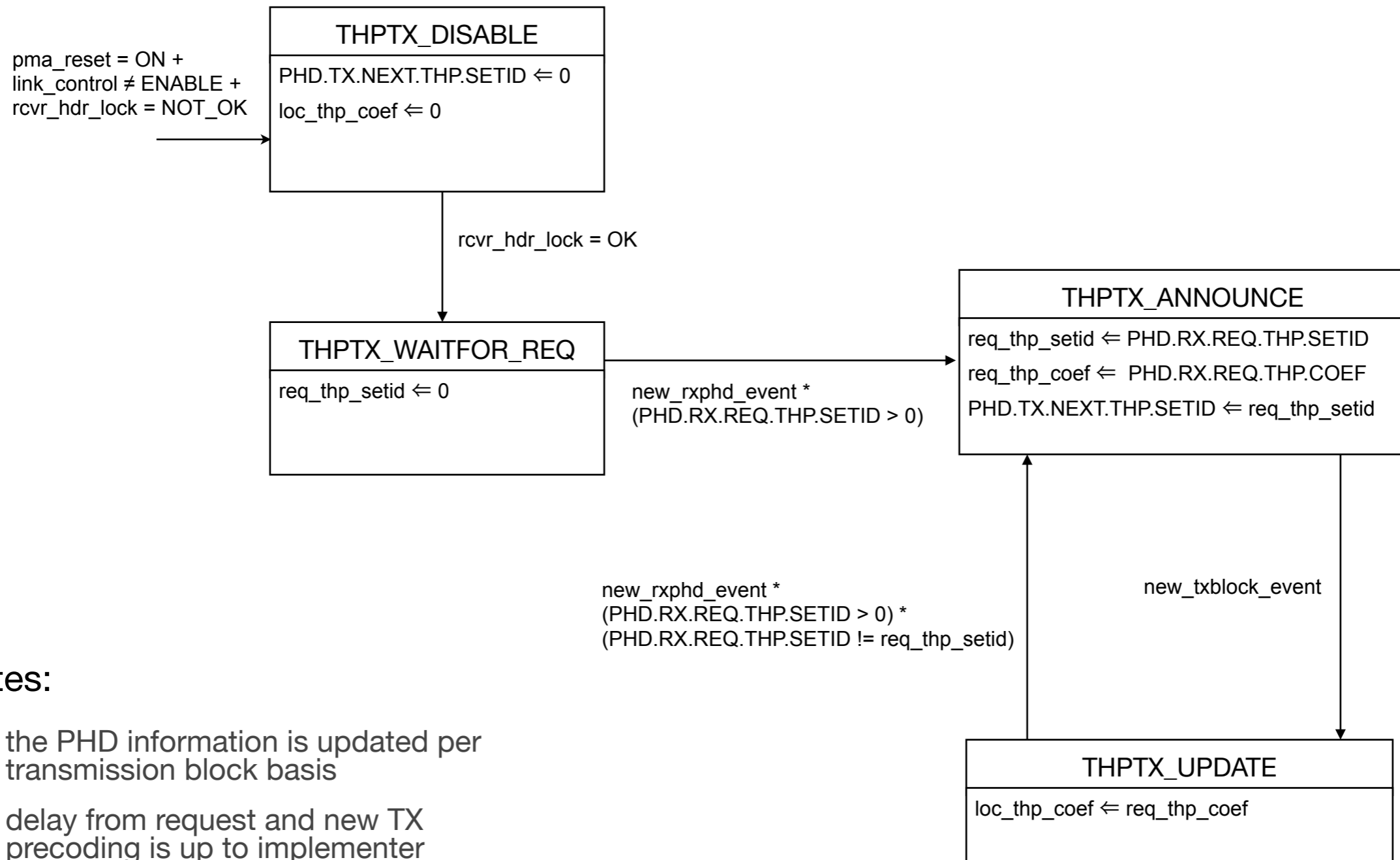

• Notes:

- the PHD information is updated per transmission block basis
- delay from request and new TX precoding is up to implementer
- always PHD.TX.NEXT.* must carry information valid for the next transmit block

Adaptive THP - THP REQ FSM

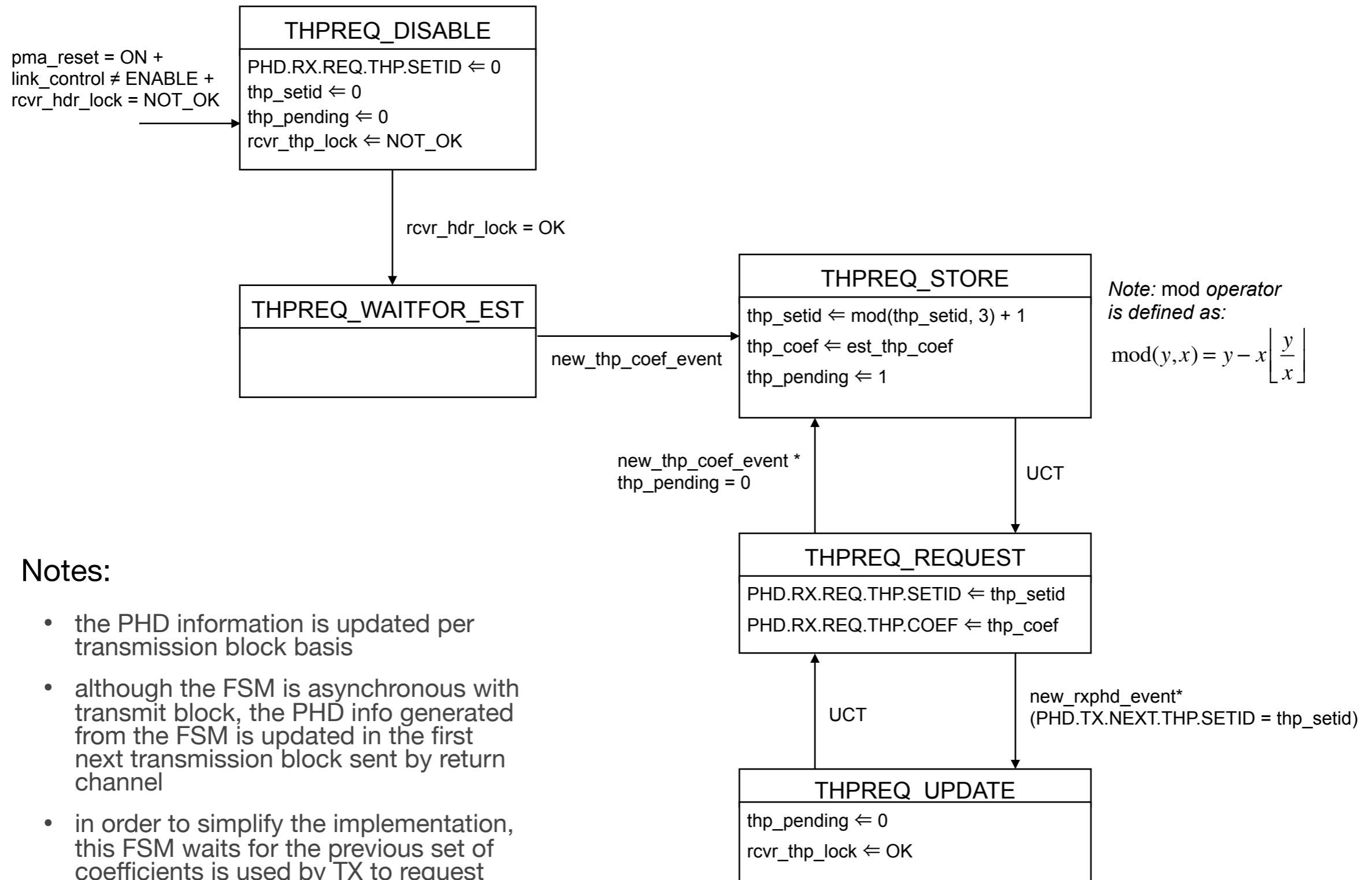

• **Notes:**

- the PHD information is updated per transmission block basis
- although the FSM is asynchronous with transmit block, the PHD info generated from the FSM is updated in the first next transmission block sent by return channel
- in order to simplify the implementation, this FSM waits for the previous set of coefficients is used by TX to request new one

Adaptive THP - variables



- `new_txblock_event`: variable set by the PCS transmit function to indicate the encoding of a new transmit block starts
 - 1: indicates the event of a new transmit block starts. The value 1 extends during one transmit symbol period, and it is synchronous with the first ZERO symbol of S1 of a transmitted block.
 - 0: indicates no new block starts.
- `loc_thp_coef`: variable set by the PMA PHY Control function that contains the local coefficients used by the PMA transmit for TH precoding of data payload sub-blocks. `loc_thp_coef` is a set of 9 real numbers representing the feedback coefficients $b(i)$
 - Coefficients are real numbers that take values in the interval $[-2, 2)$.
- `req_thp_coef`: variable set by the PCS receive function that contains the coefficients requested by the link partner to be used for THP precoding of the data payload sub-blocks. `req_thp_coef` is a set of 9 real numbers that are received in `PHD.RX.REQ.TH.PCOEF` field (see [7]).
 - Coefficients are real numbers that take values in the interval $[-2, 2)$.
- `req_thp_setid`: variable set by the PCS receive function that contains the set identifier associated to the THP coefficients requested by the link partner and that is received in `PHD.RX.REQ.TH.SETID` field
 - 0: request for changing the THP coefficients is not performed.
 - 1 .. 3: set identifier.

Adaptive THP - variables



- **thp_setid**: variable used by PMA Phy Control to store the last THP set-id requested to the link partner.
 - 0: reset value.
 - 1 .. 3: set identifier.
- **thp_pending**: variable used by the PMA Phy Control function to store the pending status of a THP configuration request.
 - 0: reset or request is not pending. THP request was attended by the link partner, which applied the requested THP coefficients for data payload precoding.
 - 1: a THP configuration request is pending.
- **thp_coef**: variable used by PMA Phy Control to store the last THP coefficients requested to the link partner. **thp_coef** is a set of 9 real numbers representing the feedback coefficients $b(i)$
 - Values: coefficients are real numbers that take values in the interval $[-2, 2)$.
- **est_thp_coef**: variable set by the PMA Receive function that contains the coefficients estimated to compensate inter-symbol interference by means of Tomlinson-Harashima Precoding. **est_thp_coef** is a set of 9 real numbers representing the feedback coefficients $b(i)$
 - Values: coefficients are real numbers that take values in the interval $[-2, 2)$.
- **new_thp_coef_event**: variable set by the PMA Receive function to indicate the estimation of THP coefficients has finished and a new set is ready.
 - 1: indicates the event of a new set of THP coefficients is ready from estimation. The value 1 extends during one receive symbol period and it may be asynchronous with the received block start.
 - 0: indicates no new set of THP coefficients is ready.



PHY quality monitor

PHY quality monitor



- The aim of this function is to determine the receiver is able to provide data reception with high reliability, i.e. low bit error rate.
- This function is in charge to determine the `loc_rcvr_status` state variable.
- Because it is required to determine the link status fast, `loc_rcvr_status` must be based on a fast estimator, i.e. it cannot be based on BER measurement.
- This function may be based on detection SNR, which is related to BER under reasonable conditions (i.e. THP equalization).
- Let's consider the average energy of a noiseless sequence of symbols belonging to a M-PAM constellation $\{-M+1, -M+3, \dots, -3, -1, 1, 3, \dots, M-3, M-1\}$:

$$E_{avg} = \frac{M^2 - 1}{3}$$

- For 16-PAM, $E_{avg} = 85$.

- From [4], we know that:
 - Minimum SNR at detector for $BER = 10^{-12}$ is: $SNR_0 \geq 25.01$ dB
 - Input BER of BCH decoder of MLCC level 1 is: $BER_{0L1} \leq 0.003323$
 - BER_{0L1} may be measured by the PHY as a function of the number of bit errors that are corrected by the BCH decoder per code-word
 - Which has to be $\leq 0.003323 \cdot 1976 = 6.5662$ corrected bits per BCH code-word
 - Equivalent to $6.5662 \cdot 8 \cdot 28 \approx \mathbf{1471}$ corrected bits per transmission block in the sensitivity point
- By the straight definition of SNR, we can define the threshold of the variance of noise in detector that cannot be overpassed to be able to provide reliable data decoding as:

$$\sigma_n^2 = \frac{E_{avg}}{SNR_0}$$

$$\Sigma = \log_2(\sigma_n^2) = \log_2(E_{avg}) - \log_2(SNR_0)$$

$$\Sigma = -1.8988$$

- Which is equivalent to say that measured variance of noise sequence in detector (n_d) has to be lower than threshold:

$$\log_2(E[n_d^2]) < \Sigma$$

- Variance of detector noise may be estimated by MER (Modulation Error Rate) measurement, as suggested by the use of notation $E[n_d^2]$
- But it can also be estimated based the BER_{0L1} measurement
- From [8], it can be demonstrated for the coded 16-PAM scheme defined in [1] that an estimate of detector noise variance can be given by:

$$E[n_d^2] = \left(\operatorname{erfc}^{-1}(2BER_{0L1})\right)^{-2}$$

where $\operatorname{erfc}(x) = \frac{2}{\sqrt{\pi}} \int_x^{\infty} e^{-t^2} dt$

- This is equivalent to: $\log_2(E[n_d^2]) = -2\log_2(\operatorname{erfc}^{-1}(2BER_{0L1}))$
- Therefore, two methods for variance of detector noise have been provided, that may be used to qualify the reliability of the link in a very fast way in IC implementation

PHY quality monitor - link margin definition



- As defined in [3], the PHY shall return to the link partner the link margin, by using the PHD.RX.LINKMARGIN field of the header
- Link margin is defined as the extra SNR available in the detector respect to minimum SNR needed to provide `loc_rcvr_status = OK`
- It is convenient to use logarithmic units for variance and SNR magnitudes because of the nature of BER characteristic as a function of SNR
- Formal definition of link margin (LM) is given by:

$$LM = \Sigma - \log_2 \left(E \left[n_d^2 \right] \right)$$

- It is important to note that Σ is implementer dependent, and the previous value of -1.8988 is only provided as lower bound; it shall have to include any implementation losses that will depend on final implementation
- It is also up to the implementer how many blocks or MLCC code-words are used, or the needed time, to obtain a good estimate of the noise variance

PHY quality monitor FSM

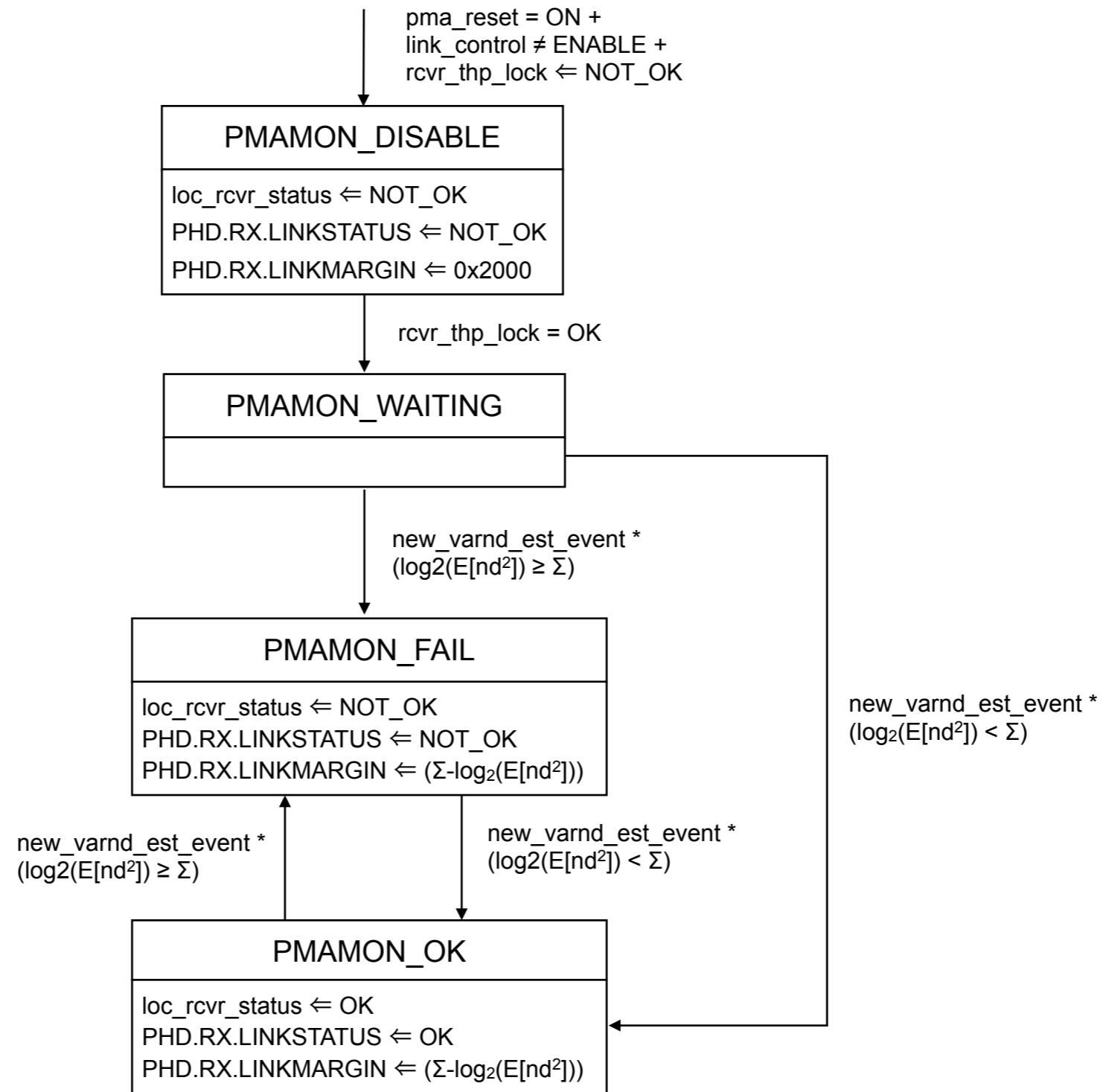

PHY quality monitor FSM - variables



- `new_varnd_est_event`: variable set by the PMA receive function to indicate a new estimation of detector noise variance is available for the state machine
 - 1: indicates the event of a new noise variance estimation. The value 1 extends one receive symbol period
 - 0: indicates no new event.

References



- [1] *Rubén Pérez-Aranda, et al., “High spectrally efficient coded 16-PAM scheme for GEPOF based on MLCC and BCH”, IEEE 802.3bv TF, Interim Meeting, January 2015*
- [2] *Rubén Pérez-Aranda, “Transmission scheme for GEPOF”, IEEE 802.3bv TF, Interim Meeting, January 2015*
- [3] *Rubén Pérez-Aranda, et al., “Physical Header Data content for PCS encoding, PHY control and OAM channel in GEPOF”, IEEE 802.3bv TF, Plenary Meeting, March 2015*
- [4] *Rubén Pérez-Aranda, et al., “Performance analysis of coded 16-PAM scheme for GEPOF. BER, MTBE, MTTFPA, PER”, IEEE 802.3bv TF, Interim Meeting, January 2015*
- [5] *Rubén Pérez-Aranda, et al., “Shannon’s capacity analysis of GEPOF for technical feasibility assessment”, IEEE GEPOF SG, Interim Meeting, May 2014*
- [6] *David Forney Jr., “Maximum-Likelihood Sequence Estimation of Digital Sequences in the Presence of Intersymbol Interference”, IEEE Trans. in Information Theory, Vol. IT-18, No. 3, May 1972, pp. 363-378*
- [7] *Rubén Pérez-Aranda, et al., “OAM channel proposal for GEPOF”, IEEE 802.3bv TF, Plenary Meeting, March 2015*
- [8] *G. D. Forney, Jr. et al., “Sphere-Bound-Achieving Coset Codes and Multilevel Coset Codes”, IEEE Trans. on Inform. Theory, vol. 46, pp. 820-850, May 2000*



Questions?