

114.8 Medium Dependent Interface (MDI)

The 1000BASE-RHx PMD is coupled to the fiber optic cabling through a connection at the Medium Dependent Interface (MDI). This subclause defines the MDI mechanical interface for 1000BASE-RHA in 114.8.1. MDI mechanical interface is not specified for 1000BASE-RHB and 1000BASE-RHC.

The transmit signal characteristics are defined at the output end of a 1 meter length (TP2) of plastic optical fiber. In the same way, the optical receive signal is defined at the output of the fiber optic cabling (TP3). Therefore, both the transmitter and the receiver optical characteristics are independent of the MDI mechanical implementation.

114.8.1 MDI mechanical interface for 1000BASE-RHA

The 1000BASE-RHA PMD is coupled to the terminated fiber optic cabling without a plug into the MDI optical receptacle.

The 1000BASE-RHA MDI receptacle shall be a duplex housing consisting of two separated slots for each direction of the link. Viewed from the link segment side of the connection, the 1000BASE-RHA MDI receptacle shall properly indicate with labeling the slot of the transmitter and the slot of the receiver. Figure 1 illustrates the MDI connector with labeling.

The 1000BASE-RHA MDI receptacle shall have defined open and close states. The close state shall guarantee a stable and resilient connection by utilizing a retention mechanism with a minimum retention force of 15 N.

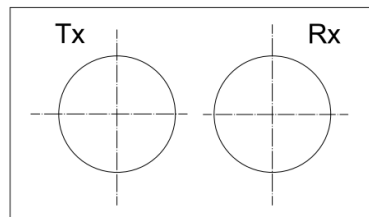

Figure 1: MDI receptacle (link segment side view)

The 1000BASE-RHA MDI receptacle shall accept link segment duplex cable compliant with specifications of buffered A4 fibers per IEC 60794-2-41.

The duplex POF cable needs to be properly terminated and split into two single jacketed fibers for connection to the 1000BASE-RHA MDI receptacle.

The POF cable shall be terminated without polishing by using a POF cutting tool (POF cutting tools are outside the scope of this specification). The termination tool may clamp the POF cable (without damaging the fibers) to prevent movement when cutting it (e.g., with a razor blade). The termination process shall provide a cable compliant with the following specifications:

- 1) The resultant fiber end facets are perpendicular to the cable axis with a maximum error of $\pm 5^\circ$.
- 2) The flatness of the fiber end facet has an insertion loss of less than 1.5 dB, per butt coupling of two resultant segments after termination.

The duplex cable splitting shall have sufficient length to ensure:

- 1) full insertion and guidance inside the MDI receptacle slot,
- 2) and bend radius over 25 mm.

The connector vendor shall properly indicate the minimum split length. Figure 2a) illustrates the duplex POF cable splitting and Figure 2b) the fiber cable connection to 1000BASE-RHA MDI receptacle.

One of the jackets of the duplex POF cable shall have marking. A possible marking is illustrated in Figure 2a) and Figure 2b). Such marking can facilitate installation when the optical transmitters of the link are off. The marking requirements are application specific and shall follow the requirements in IEC 60794-2-41.

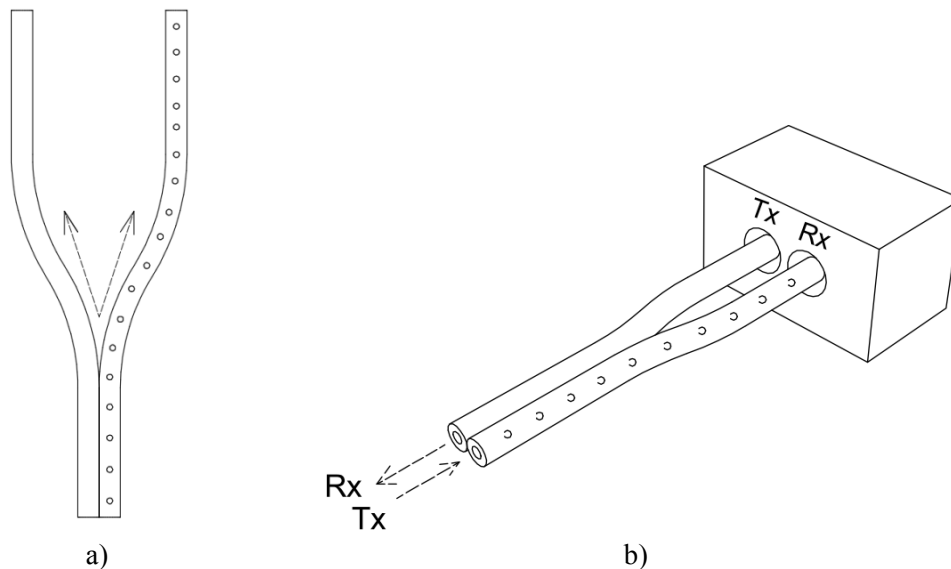

Figure 2: a) Duplex POF cable splitting, b) 1000BASE-H MDI receptacle to POF cable connection

Two different installation scenarios can be considered for correct link segment crossover: the scenario where visible transmit light is used and the scenario where the fiber cable marking is used.

When the remote link partner is transmitting, the fiber used by the link partner to transmit can be easily distinguished because of the 1000BASE-RHA visible light. This fiber is connected to the local receiver, and the other fiber of duplex cable is connected from the local transmitter to the remote receiver. When the remote link partner is not transmitting the cable specific marking shall be used to implement a single crossover between the link partners identifying the correct insertion of the fiber ends into the MDI receptacle.