

Agenda and General Information

IEEE P802.3bz 2.5G/5GBASE-T Task Force

David Chalupsky, Intel

Dallas, Texas
November, 2015

Agenda

- Welcome and Introductions
- Approve Agenda
- Approve minutes from last meeting
- Goals for this meeting
- Big Ticket Items
- Reflector and Web
- Ground Rules
- IEEE
 - Structure, Bylaws and Rules
 - Call for Patents
 - IEEE Standards Process
- Liaisons and Communications
- Presentations and comment resolution
- Motions and Closing Business
- Future Meetings

Motion #1

- Approve the agenda
- M:
- 2nd:
- (procedural, >50%)
- Result:



Motion #2

- Approve the minutes from the September 2015 P802.3bz meeting.
- M:
- 2nd:
- (procedural, >50%)
- Result:

Task Force Decorum



- Press (i.e., anyone reporting publicly on this meeting) are to announce their presence (December 2013 IEEE-SA Standards Board Ops Manual 5.3.3.5)
- Photography or recording by permission only (December 2013 IEEE-SA Standards Board Ops Manual 5.3.3.4)
- Cell phone ringers off
- Wear your badges at all times in meeting areas
 - Help the hotel security staff improve the general security of the meeting rooms
 - **PCs HAVE BEEN STOLEN** at previous meetings
 - **DO NOT** assume that meeting areas are secure
- Please observe proper decorum in meetings

IEEE P802.3bz 2.5G/5GBASE-T Task Force Project Information

- Task Force Organization

- David Chalupsky, Chair
- George Zimmerman, Chief Editor
- Chris DiMinico, Chair, Use Case ad hoc
- German Feyh, Chair, Enterprise Noise and Use Case Analysis ad hoc (ENUCA)
- Jon Lewis, Secretary
- Peter Jones, Chair, Architecture ad hoc

- Task Force web and reflector information

- Reflector information: <http://ieee802.org/3/NGBASET/reflector.html>
 - Shares reflector with P802.3bq
- Home page: <http://ieee802.org/3/bz/index.html>
- PAR - <http://www.ieee802.org/3/bz/P802.3bz.pdf>
- CSD - http://www.ieee802.org/3/bz/802d3_NGEABT_CSD_802.3_WG_approved_12-march-15.pdf
- Objectives - http://www.ieee802.org/3/bz/ngeabt_objectives_802.3WG_approved_0315.pdf
- Private area: <http://ieee802.org/3/bz/private/index.html>
 - Note: The draft, and any other content, is posted for your review only, and neither the content nor access information should be copied or redistributed to others in violation of document copyrights
 - User = xxxxx password = xxxxxx

Next Generation Enterprise Access BASE-T PHY Objectives

- Support full duplex operation only
- Preserve the 802.3 / Ethernet frame format utilizing the 802.3 MAC
- Preserve minimum and maximum Frame Size of current 802.3 standard
- Support Auto-Negotiation (Clause 28)
- Support optional Energy Efficient Ethernet (Clause 78)
- Support local area networks using point-to-point links over structured cabling topologies
- Do not preclude meeting FCC and CISPR EMC requirements
- Support PoE (Clause 33)
 - including amendments made by 802.3bt “DTE Power via MDI over 4-Pair Task Force”
- Support MAC data rates of 2.5 Gb/s and 5 Gb/s
- Support a BER better than or equal to 10^{-12} at the MAC/PLS service interface (or the frame loss ratio equivalent)
- Select copper media from ISO/IEC 11801:2002, with any appropriate augmentation to be developed through work of 802.3 in conjunction with SC25/WG3 and TIA TR42
- Define a 2.5 Gb/s PHY for operation over
 - Up to at least 100m on four-pair Class D (Cat5e) balanced copper cabling on defined use cases and deployment configurations
- Define a 5 Gb/s PHY for operation over
 - Up to at least 100m on Class E (Cat6) balanced copper cabling on defined use cases and deployment configurations
 - Up to 100m on Class D (Cat5e) balanced copper cabling on defined use cases and deployment configurations

Plans for the Week

Goals for the meeting

- Resolve comments on D1.1
- Authorize generation of D1.2
- Prepare for working group ballot
 - no more TBDs
 - Schedule approved in September calls for requesting WG ballot at January 802.3 meeting

Big Ticket Items

- See Editor's Report

IEEE P802.3bz Schedule

2014	November		CFI
2015	January		1st SG meeting
	March		2nd SG meeting
2015	May	D0.1	1st TF mtg, preliminary draft
	July	D1.0	start TF review
	September	D1.1	
	November	D1.2	technically complete - presubmit for WG ballot. Must be available 10days prior to 802.3 mtg
2016	January	D2.0	30-day IWGB: 1/23-2/21.
	February	D2.1	extra interim; 2.1 needs to be avail 10 days before march closing plenary, 3/7
	March	D2.2	conditional SB for May
	May	D3.0	
	July	D3.1	
	September	D3.2	Oct 17 final recirc start for deadline Dec Revcom
	November		
	December		Approved

Adopted by the task force September 2015

Ground Rules

- Based upon IEEE 802.3 Rules
 - Foundation based upon Robert's Rules of Order
 - Anyone in the room may speak
 - Anyone in the room may vote
- **RESPECT**... give it, get it
- NO product pitches
- NO corporate pitches
- NO prices!!!
 - This includes costs, ASPs, etc. no matter what the currency
- NO restrictive notices

Attendance

- Tutorial Material on attendance tool
 - http://ieee802.org/3/minutes/attendance_procedures.pdf
- Access details
 - URL: <http://imat.ieee.org/>
 - Pw =
 - Please sign the 802.3bq/P802.3bz attendance book that will be circulated each day
 - IMAT records attendance for 802.3 records
 - Our book records for minutes

IEEE Structure

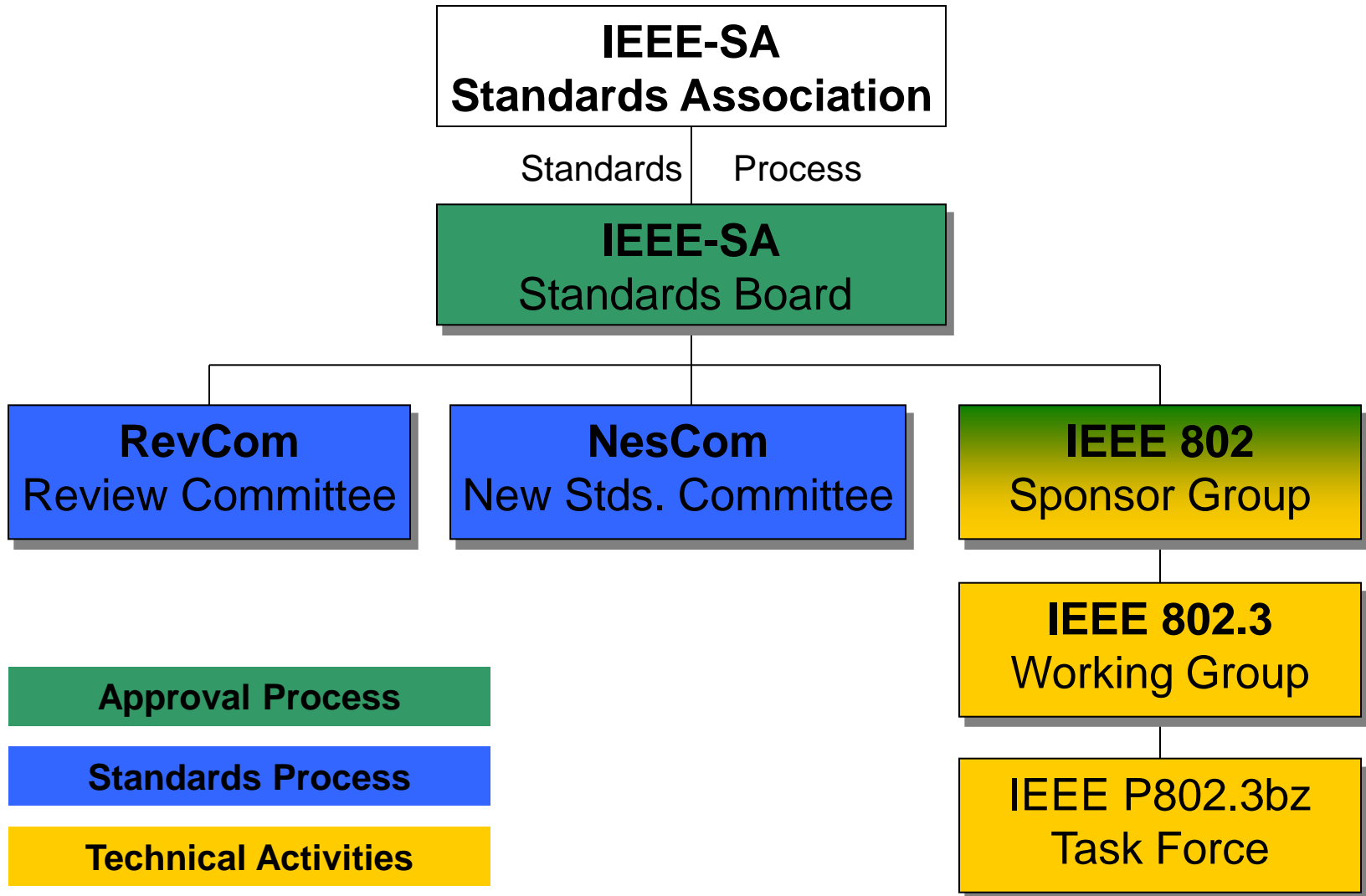

Important Bylaws and Rules

- **IEEE-SA Operations Manual**
http://standards.ieee.org/develop/policies/sa_opman/
- **IEEE-SA Standards Board Bylaws**
<http://standards.ieee.org/develop/policies/bylaws/>
- **IEEE-SA Standards Board Operations Manual**
<http://standards.ieee.org/develop/policies/opman/>
- **IEEE 802 LAN/MAN Standards Committee (LMSC) Policies and Procedures**
<http://standards.ieee.org/about/sasb/audcom/pnp/LMSC.pdf>
- **IEEE 802 LAN/MAN Standards Committee (LMSC) Operations Manual**
<http://www.ieee802.org/devdocs.shtml>
- **IEEE 802 LAN/MAN Standards Committee (LMSC) Working Group (WG) Policies and Procedures**
<http://www.ieee802.org/devdocs.shtml>
- **IEEE 802.3 Working Group Operating Rules**
http://ieee802.org/3/rules/P802_3_rules.pdf

Instructions for the WG Chair

The IEEE-SA strongly recommends that at each WG meeting the chair or a designee:

- **Show slides #1 through #4 of this presentation**
- **Advise the WG attendees that:**
 - The IEEE's patent policy is described in Clause 6 of the *IEEE-SA Standards Board Bylaws*;
 - Early identification of patent claims which may be essential for the use of standards under development is strongly encouraged;
 - There may be Essential Patent Claims of which the IEEE is not aware. Additionally, neither the IEEE, the WG, nor the WG chair can ensure the accuracy or completeness of any assurance or whether any such assurance is, in fact, of a Patent Claim that is essential for the use of the standard under development.
- **Instruct the WG Secretary to record in the minutes of the relevant WG meeting:**
 - That the foregoing information was provided and that slides 1 through 4 (and this slide 0, if applicable) were shown;
 - That the chair or designee provided an opportunity for participants to identify patent claim(s)/patent application claim(s) and/or the holder of patent claim(s)/patent application claim(s) of which the participant is personally aware and that may be essential for the use of that standard
 - Any responses that were given, specifically the patent claim(s)/patent application claim(s) and/or the holder of the patent claim(s)/patent application claim(s) that were identified (if any) and by whom.
- The WG Chair shall ensure that a request is made to any identified holders of potential essential patent claim(s) to complete and submit a Letter of Assurance.
- It is recommended that the WG chair review the guidance in *IEEE-SA Standards Board Operations Manual* 6.3.5 and in FAQs 14 and 15 on inclusion of potential Essential Patent Claims by incorporation or by reference.

Note: **WG** includes Working Groups, Task Groups, and other standards-developing committees with a PAR approved by the IEEE-SA Standards Board.



Participants, Patents, and Duty to Inform

All participants in this meeting have certain obligations under the IEEE-SA Patent Policy.

- Participants [Note: Quoted text excerpted from IEEE-SA Standards Board Bylaws subclause 6.2]:
 - “Shall inform the IEEE (or cause the IEEE to be informed)” of the identity of each “holder of any potential Essential Patent Claims of which they are personally aware” if the claims are owned or controlled by the participant or the entity the participant is from, employed by, or otherwise represents
 - “Should inform the IEEE (or cause the IEEE to be informed)” of the identity of “any other holders of potential Essential Patent Claims” (that is, third parties that are not affiliated with the participant, with the participant’s employer, or with anyone else that the participant is from or otherwise represents)
- The above does not apply if the patent claim is already the subject of an Accepted Letter of Assurance that applies to the proposed standard(s) under consideration by this group
- Early identification of holders of potential Essential Patent Claims is strongly encouraged
- No duty to perform a patent search

Patent Related Links

All participants should be familiar with their obligations under the IEEE-SA Policies & Procedures for standards development.

Patent Policy is stated in these sources:

IEEE-SA Standards Boards Bylaws

<http://standards.ieee.org/develop/policies/bylaws/sect6-7.html#6>

IEEE-SA Standards Board Operations Manual

<http://standards.ieee.org/develop/policies/opman/sect6.html#6.3>

Material about the patent policy is available at

<http://standards.ieee.org/about/sasb/patcom/materials.html>

If you have questions, contact the IEEE-SA Standards Board Patent Committee Administrator at patcom@ieee.org or visit <http://standards.ieee.org/about/sasb/patcom/index.html>

This slide set is available at
<https://development.standards.ieee.org/myproject/Public/mytools/mob/slideset.ppt>



Call for Potentially Essential Patents

- If anyone in this meeting is personally aware of the holder of any patent claims that are potentially essential to implementation of the proposed standard(s) under consideration by this group and that are not already the subject of an Accepted Letter of Assurance:
 - Either speak up now or
 - Provide the chair of this group with the identity of the holder(s) of any and all such claims as soon as possible or
 - Cause an LOA to be submitted

Other Guidelines for IEEE WG Meetings

- **All IEEE-SA standards meetings shall be conducted in compliance with all applicable laws, including antitrust and competition laws.**
 - **Don't discuss the interpretation, validity, or essentiality of patents/patent claims.**
 - **Don't discuss specific license rates, terms, or conditions.**
 - Relative costs, including licensing costs of essential patent claims, of different technical approaches may be discussed in standards development meetings.
 - Technical considerations remain primary focus
 - **Don't discuss or engage in the fixing of product prices, allocation of customers, or division of sales markets.**
 - **Don't discuss the status or substance of ongoing or threatened litigation.**
 - **Don't be silent if inappropriate topics are discussed ... do formally object.**

See *IEEE-SA Standards Board Operations Manual*, clause 5.3.10 and “Promoting Competition and Innovation: What You Need to Know about the IEEE Standards Association’s Antitrust and Competition Policy” for more details.

Overview of IEEE 802.3 Standards Process (1/5)- Study Group Phase

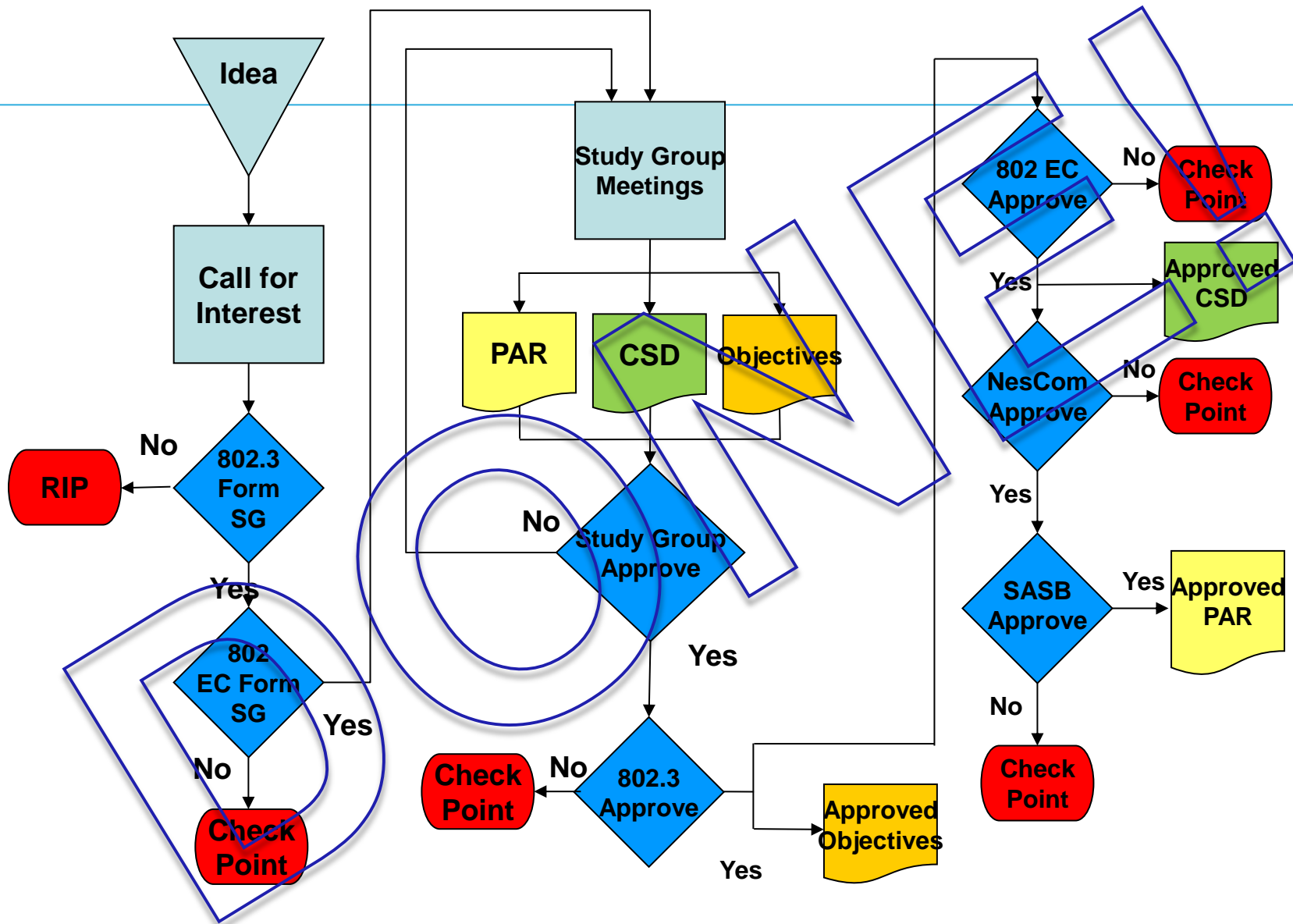

Note: At "Check Point", either the activity is ended, or there may be various options that would allow reconsideration of the approval.

Overview of IEEE 802.3 Standards Process (2/5) – Task Force Comment Phase

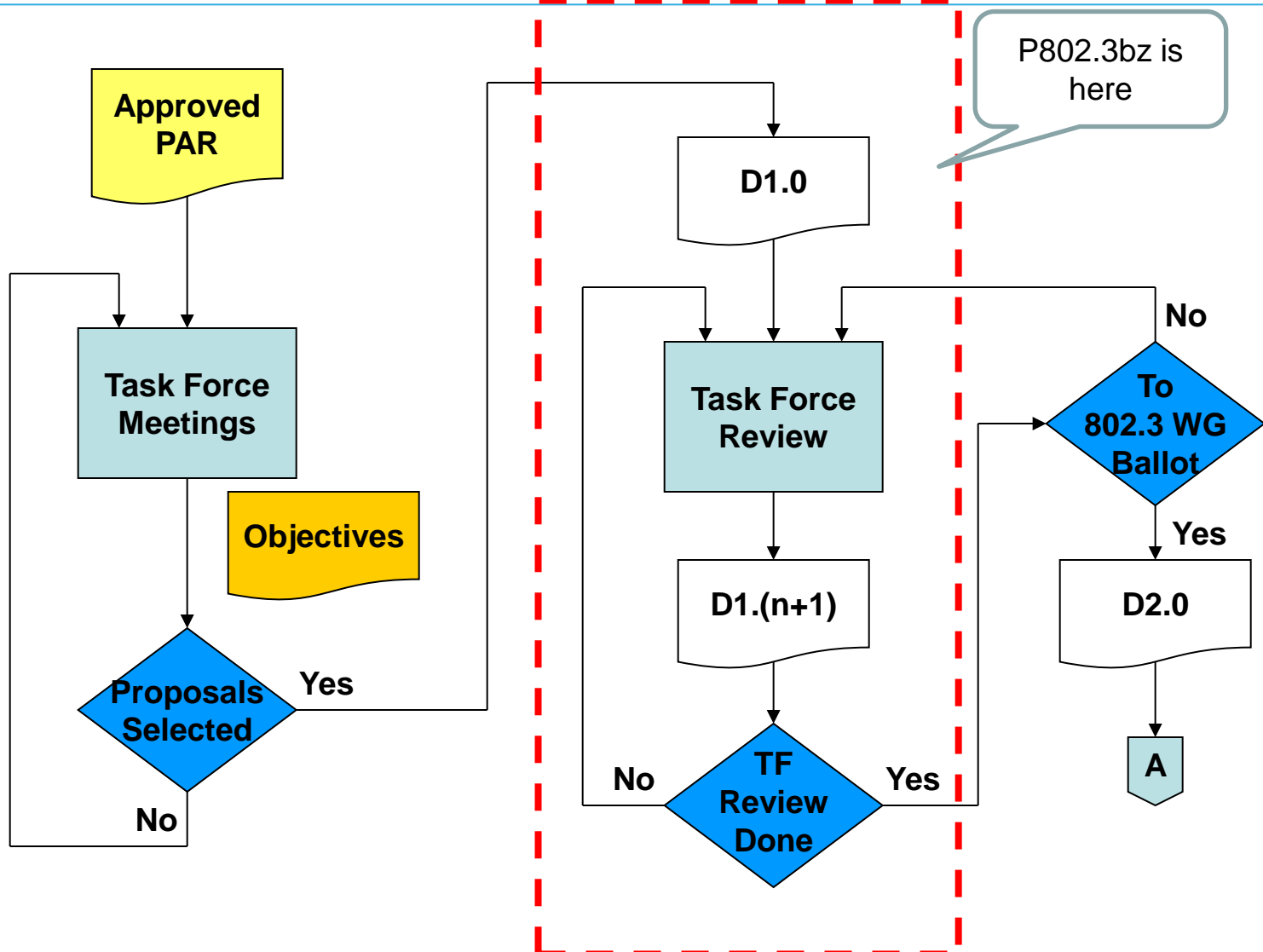

Overview of IEEE 802.3 Standards Process (3/5) – Working Group Ballot Phase

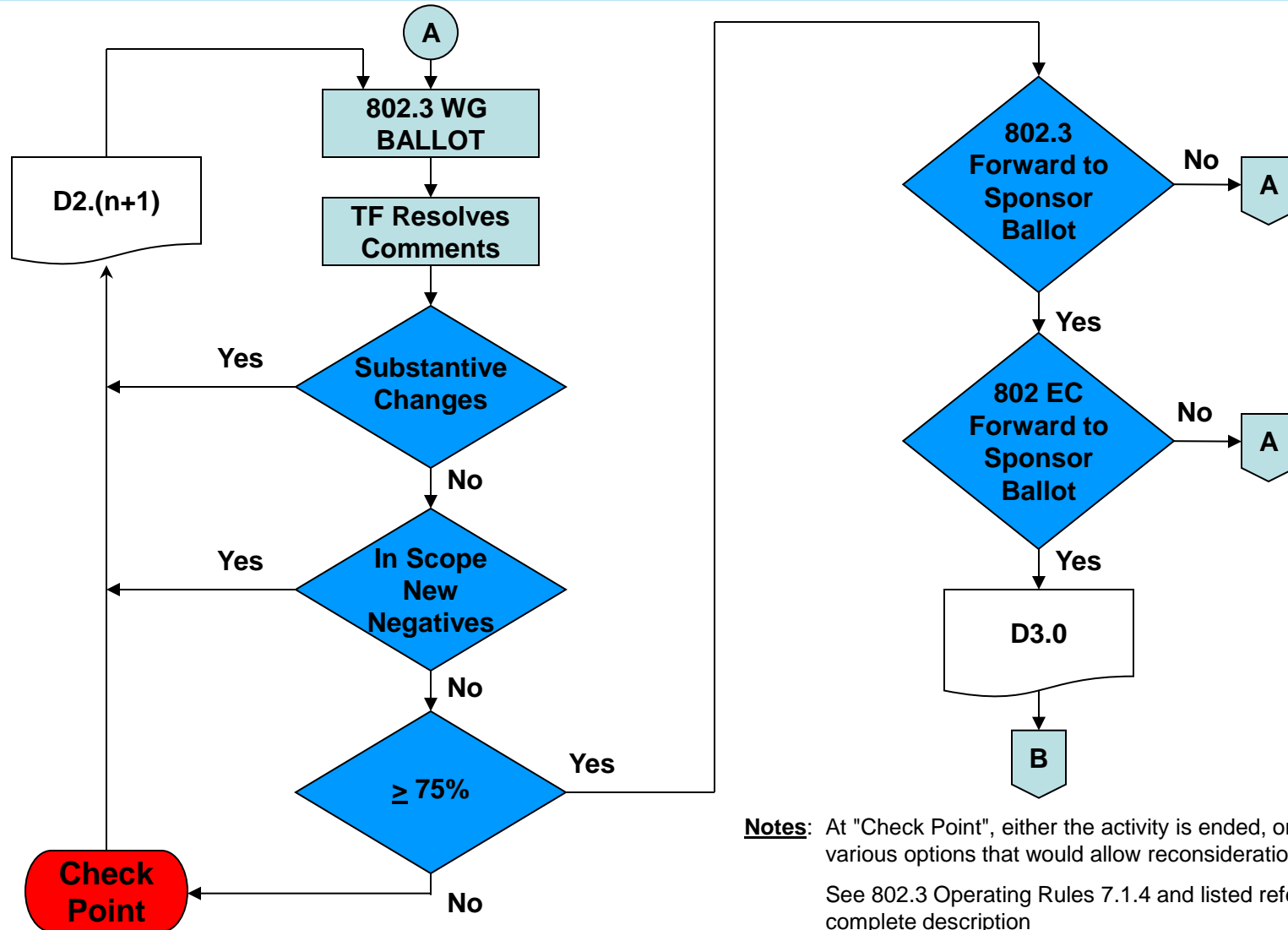

Notes: At "Check Point", either the activity is ended, or there may be various options that would allow reconsideration of the approval. See 802.3 Operating Rules 7.1.4 and listed references for complete description

Overview of IEEE 802.3 Standards Process (4/5)- Sponsor Ballot Phase

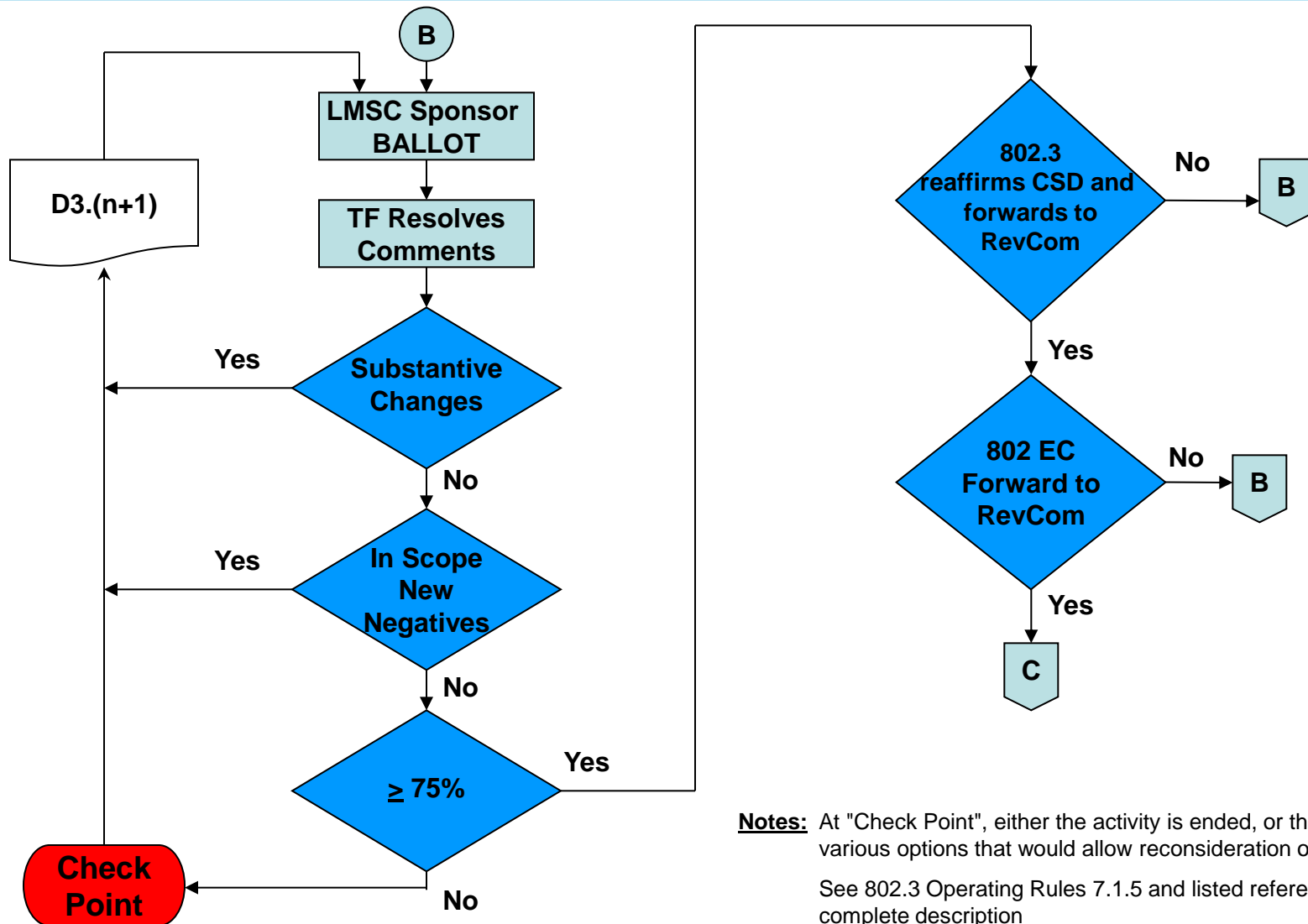

Notes: At "Check Point", either the activity is ended, or there may be various options that would allow reconsideration of the approval. See 802.3 Operating Rules 7.1.5 and listed references for complete description

Overview of IEEE 802.3 Standards Process (5/5) – Final Approvals / Standard Release

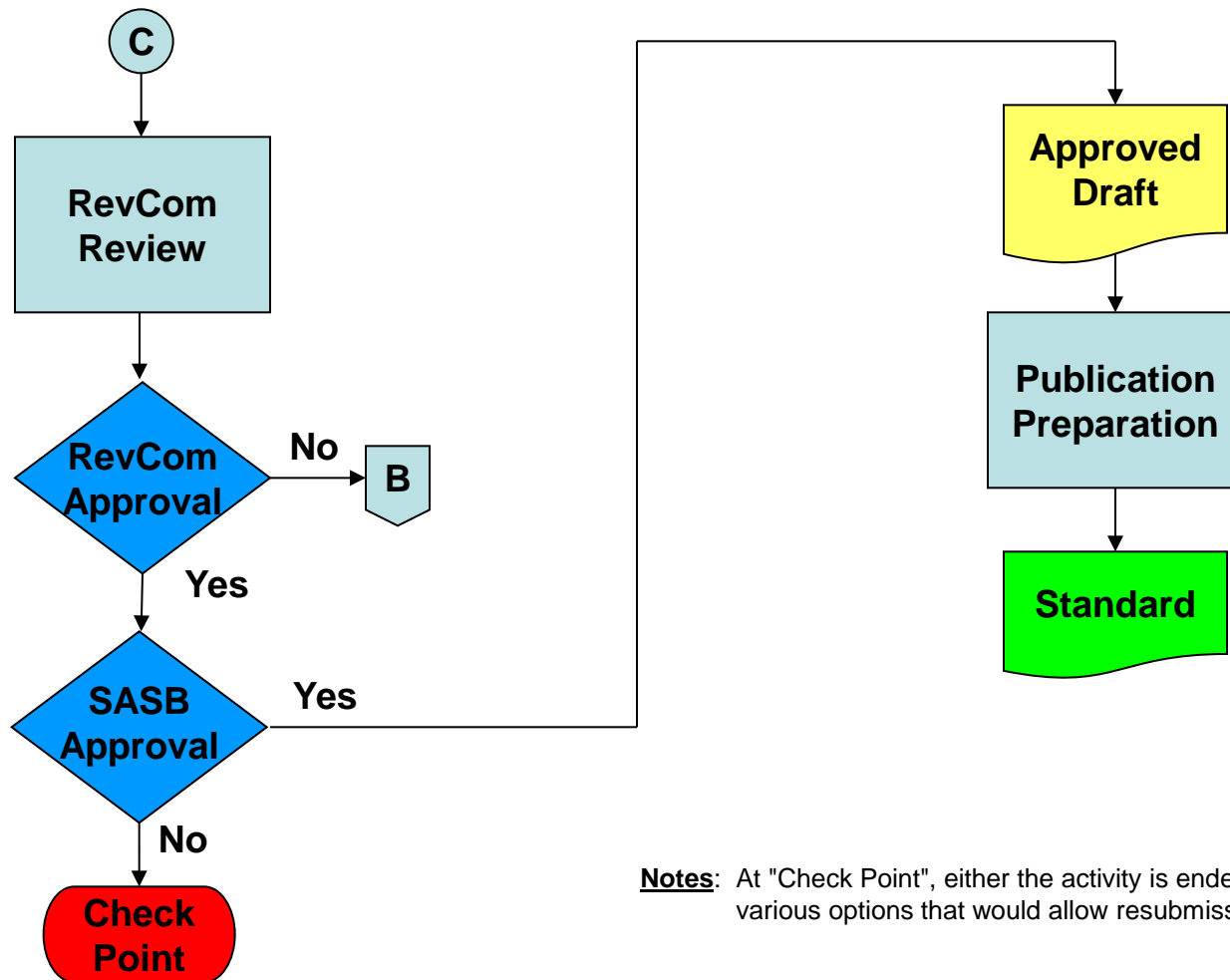

Notes: At "Check Point", either the activity is ended, or there may be various options that would allow resubmission for approval.

Liaisons and Communications

- No new incoming liaisons
- Task force liaised D1.1 to both ISO & TIA

Note to Presenters

- Filename conventions:
 - *presenterlastname_3bq_XYr_mmyy.pdf*
 - *presenterlastname_3bz_XYr_mmyy.pdf*
 - XY is presentation number, i.e. 01, 02 ,03
 - For this meeting
 - Revisions (r) are a,b,c, etc.
 - No spaces in file name
 - Example: carlson_3bq_01a_0713.pdf

Agenda notes

- 2.5 days total allocated to P802.3bq and P802.3bz
 - Monday afternoon, Tuesday & Wednesday
 - Reunion H
- P802.3.bq begins Monday at 1pm
- P802.3bz begins after bq comment resolution complete
 - With the exception of those items that may benefit from discussion in bz before closing...
 - Likely Tuesday morning start. Please be flexible.
- Agenda is largely driven by comment resolution
 - Start with ad hoc reports
 - See Editor's Report for sequence of comment topics
 - Presentations taken as necessary to support comment resolution



Future Meetings

- See: <http://www.ieee802.org/3/interims/index.html>
- See: <http://802world.org/plenary/future-plenary-sessions>

- **January 2016 Interim Week of Jan 18**
 - Hyatt Regency Atlanta, Atlanta, GA. Hosted by IEEE 802
 - Early registration closes Dec 4th
- **March 2016 Plenary Week of March 13**
 - The Venetian Macao, Macao SAR, P.R. China
- **May 2015 Hosted by Ethernet Alliance**
 - Week of May 23rd ...location TBD
- **July 24-29 – San Diego, CA USA**
 - Manchester Grand Hyatt
 -

- Anyone interested in hosting a interim meeting contact the IEEE 802.3 Executive Secretary [Steve Carlson](#).

Thank You!