



Inter-operability risk for 50GBASE-CR with Draft 3.3 ERL specifications

Mike Dudek Cavium

Tao Hu Cavium

Presented at 6-27-18 802.3cd ad hoc.

- **This presentation is related to comment r03-18. It investigates the effect on system performance as measured by COM of changes in ERL performance. It builds on work presented in dudek_3cd_01_0318 and dudek_3cd_01a_0518.**
- **No cable S parameters are available on the web site for cables with ERL close to the specification limit so Cavium CA2 was created to see what the effect would be on system performance with hosts with different ERL. The creation method and more details of this cable and the others used in the analysis are given in the back-up. In addition two cables (Cavium M2 and Cavium M3) with marginal passing performance were measured and added to the data set.**
- **All hosts used in this presentation pass all the draft 3.3 specifications including Pmax/Vf except for the marginal fail for Pmax/Vf of the standard COM Tx.**



Cable assembly:

Cable ERL results

	COM TX 30mm (dB)	ERL11 (dB)	ERL22 (dB)
TE w/ XTALK	4.19	20.52	19.47
CAVIUM CA2	3.56	10.70	16.13
Cavium M2 w/ XTALK	4.10	10.65	12.77
Cavium M3 w/ XTALK	3.15	13.35	12.24



Host Tx and system performance

Transmitter parameters at TP2

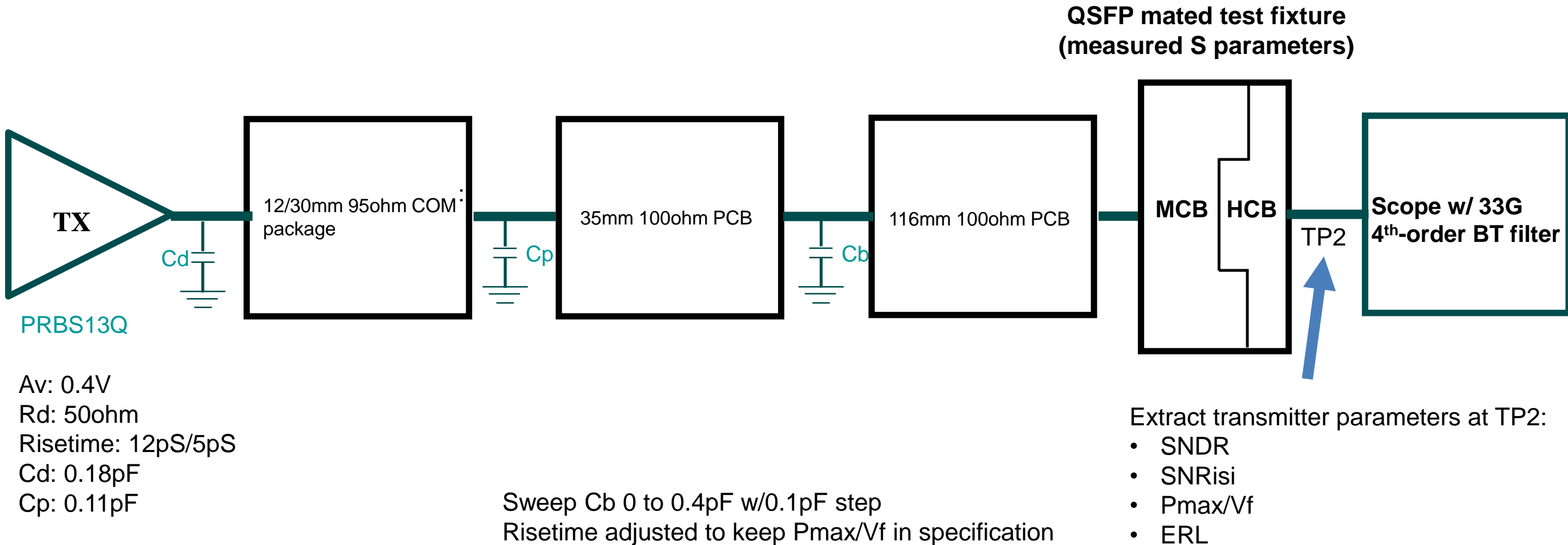

Transmitter parameters at TP2 w/o host trace

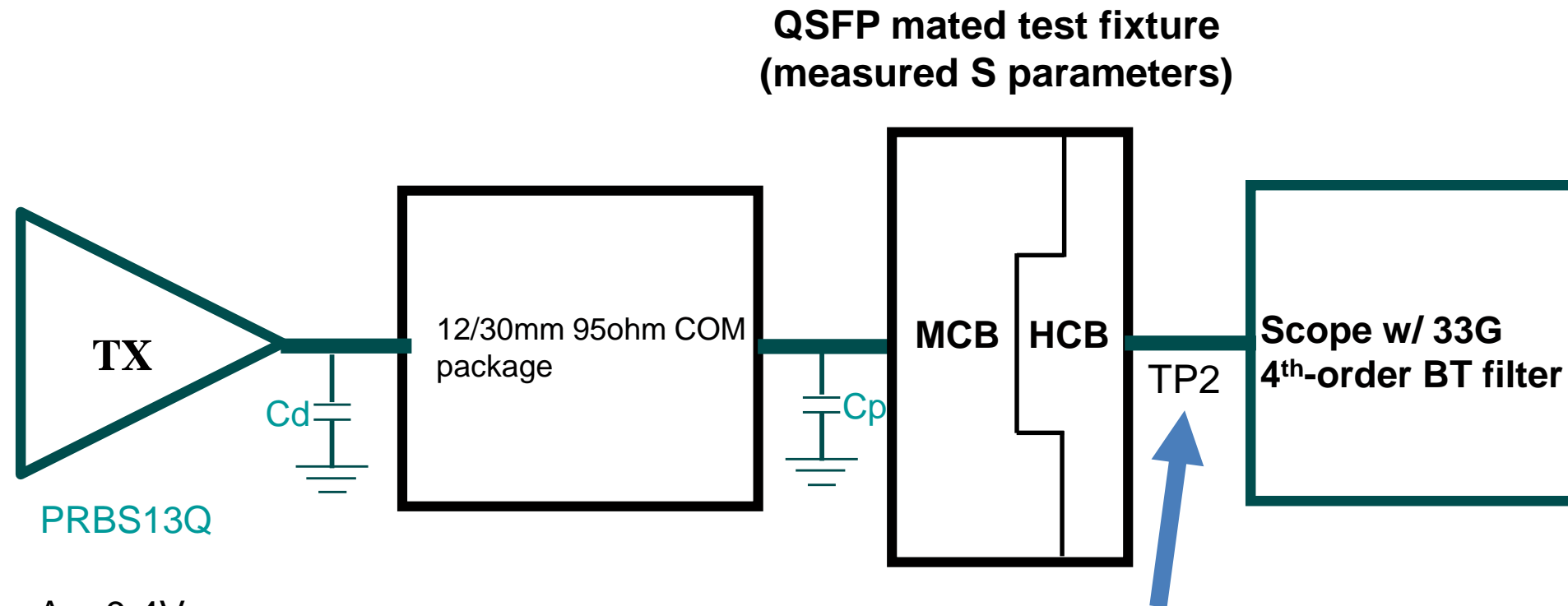

Av: 0.4V
Rd: 50ohm
Risetime: 12pS
Cd: 0.18pF
Cp: 0.11pF

Extract transmitter parameters at TP2:

- SNDR
- SNR_{isi}
- P_{max}/V_f
- ERL

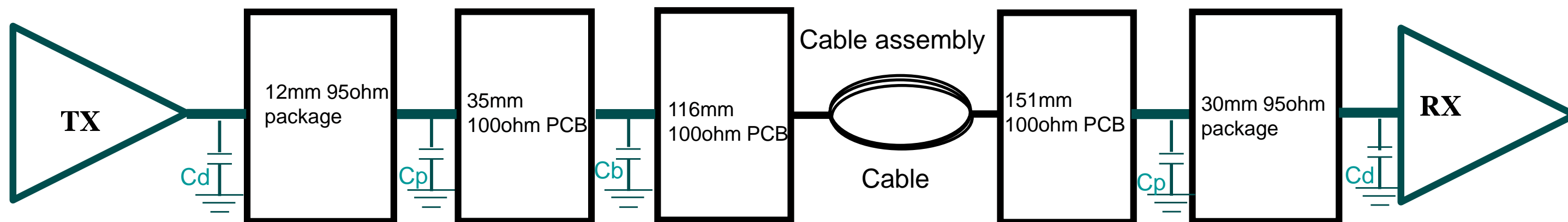

A_v : 0.415V
 A_{fe} : 0.415V
 A_{ne} : 0.604V
 R_d : 50ohm
 C_d : 0.18pF
 C_p : 0.11pF

Thru channel includes C_b on TX host trace. XTALK channels don't include C_b .
 Same host Tx's used as for Transmitter parameter measurement
 Other parameters refer to table 136-15

COM for Cavium CA2

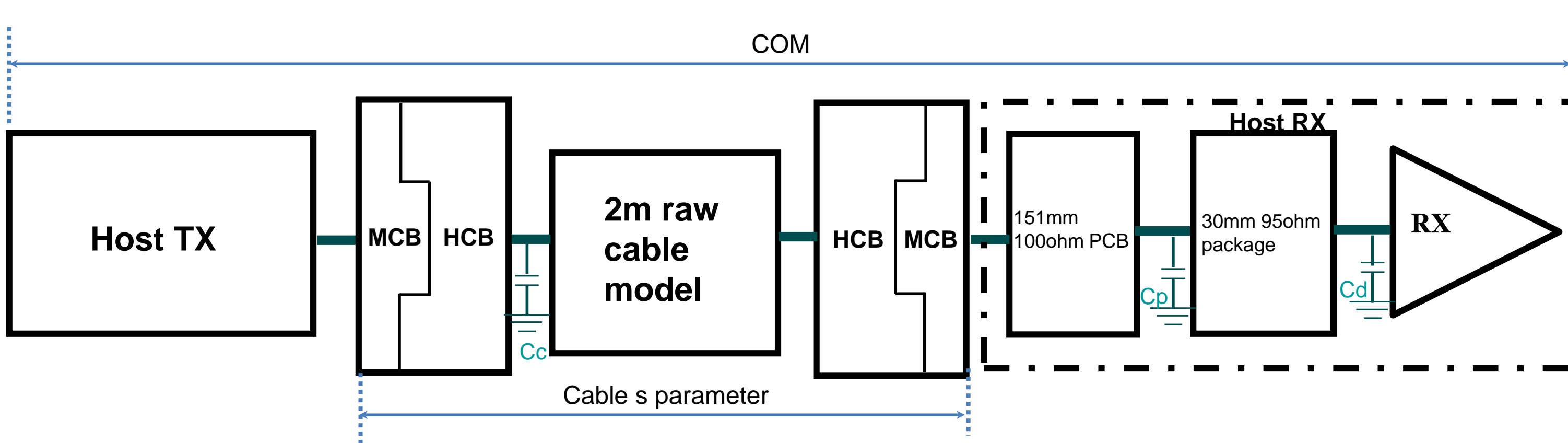

Av: 0.415V
Afe: 0.415V
Ane: 0.604V
Rd: 50ohm
Cd: 0.18pF
Cp: 0.11pF
Cc: 0.27pF

D3.3 parameters

Host	Die risetime (pS)	Cb (pF)	Pmax/Vf	SNRisi(dB)	ERL22 (dB)	ERL+ 40LOG10 (pmax/vf) (dB)	COM TE (dB)	COM CAVIUM CA2 (dB)	COM CAVIUM M2 w/XTLK (dB)	COM CAVIUM M3 w/ XTALK (dB)
12mm TX pkg+35mm brd +Cb+116mm brd+Mated QSFP test fixture	12	0	0.517	34.28	18.9	7.44	4.58	3.81	4.55	3.60
	12	0.1	0.512	32.71	17.81	6.18	4.10	3.49	4.27	3.50
	12	0.2	0.502	30.08	15.83	3.86	3.38	2.88	3.61	3.05
30mm TX pkg+35mm brd +Cb+116mm brd+Mated QSFP test fixture	12	0	0.484	32.23	19.27	6.66	4.19	3.56	4.10	3.15
12mm TX pkg+Mated QSFP test fixture	12	0	0.731	27.67	12.69	7.25	5.16	3.62	5.75	5.07
30mm TX pkg+Mated QSFP test fixture	12	0	0.68	28.86	13.52	6.82	5.11	3.81	5.42	4.85
12mm TX pkg+35mm brd +Cb+116mm brd+Mated QSFP test fixture	5	0.3	0.508	27.68	14.16	2.39	2.88	2.40	3.07	2.59
	5	0.4	0.491	25.98	12.84	0.48	2.18	1.62	2.24	1.85
30mm TX pkg+35mm brd +Cb+116mm brd+Mated QSFP test fixture	5	0	0.505	32.53	19.27	7.40	4.55	3.85	4.51	3.43

This is the Standard 30mm COM configuration

COM vs. adjusted Host ERL (D3.3) All points meet Pmax/Vf spec

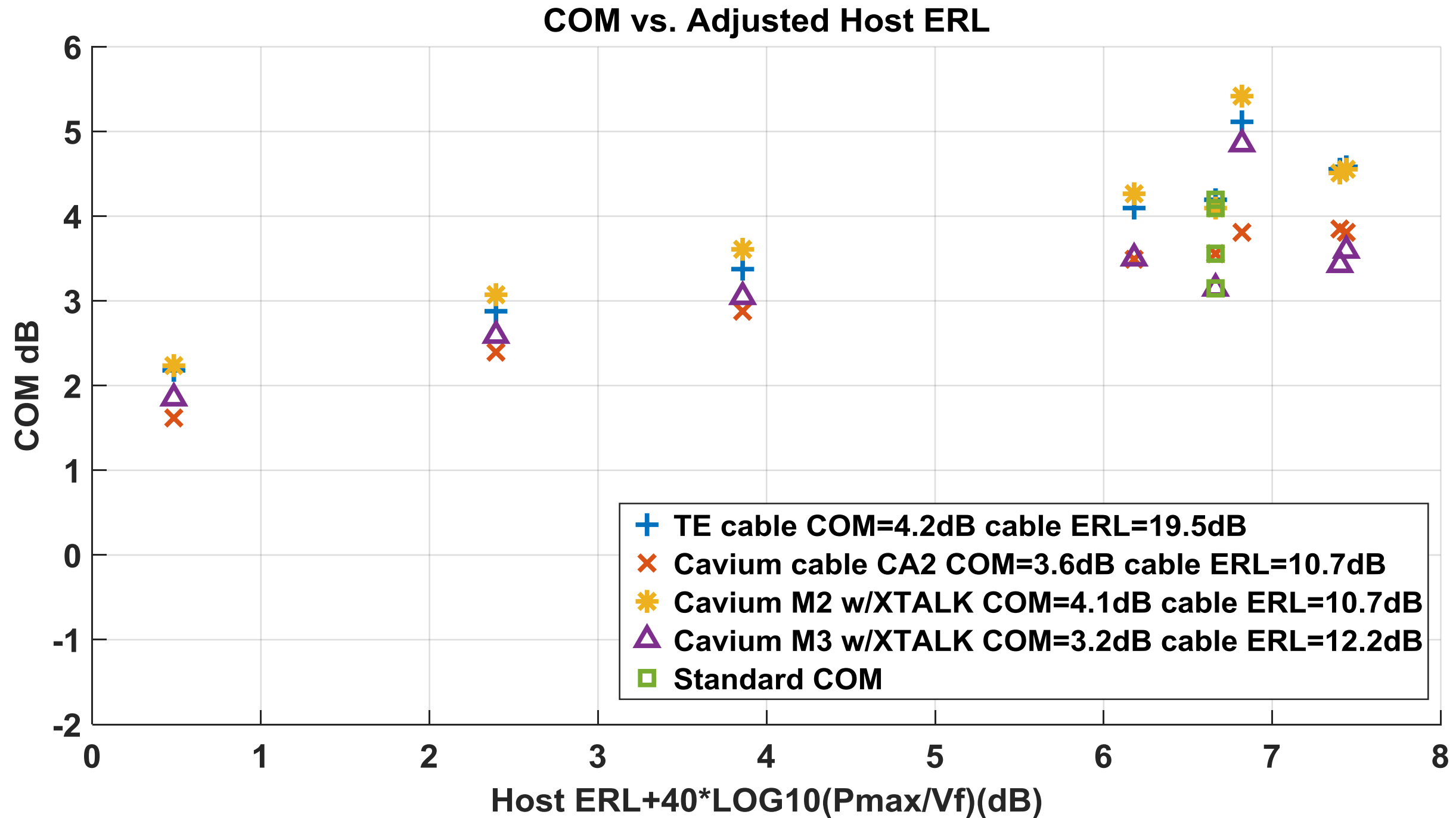

Conclusions and further work on host Tx

- **The long host with the Cb capacitance at 0.4pF provides bad system performance on all these cables. It should fail the Tx specification as it is a significant inter-operability risk.**
- **An investigation was made to see what about this host was causing the problem.**
- **It was noticed that this host had significantly poorer performance on all the cables independent of whether the cables had low ERL, (although a low ERL on the cable made it worse).**
- **It was also noticed that the SNR_{Risi} for this host was low and P_{max}/V_f was also low.**
- **Another host Tx was therefore constructed by moving Cb to be closer to TP2 such that ERL and P_{max}/V_f were similar but SNR_{Risi} was significantly better. The details of the host construction are in the back-up.**

D3.3 parameters

Host	Die risetime (pS)	Cb (pF)	Pmax/Vf	SNRisi(dB)	ERL22 (dB)	ERL+ 40LOG10 (pmax/vf) (dB)	COM TE (dB)	COM CAVIUM CA2 (dB)	COM CAVIUM M2 w/XTLK (dB)	COM Cavium M3 w/ XTALK (dB)
12mm TX pkg+Mated QSPF test fixture	12	0	0.731	27.67	12.69	7.25	5.16	3.62	5.75	5.07
12mm TX pkg+35mm brd +Cb+116mm brd+Mated QSPF test fixture	5	0.3	0.508	27.68	14.16	2.39	2.88	2.40	3.07	2.59
	5	0.4	0.491	25.98	12.84	0.48	2.18	1.62	2.24	1.85
12mm TX pkg+141mm brd +Cb+10mm brd+Mated QSPF test fixture	15	0.2	0.491	29.52	12.74	0.39	3.43	2.37	3.44	2.73

Additional host Tx

COM vs. adjusted Host ERL (D3.3) All points meet Pmax/Vf spec

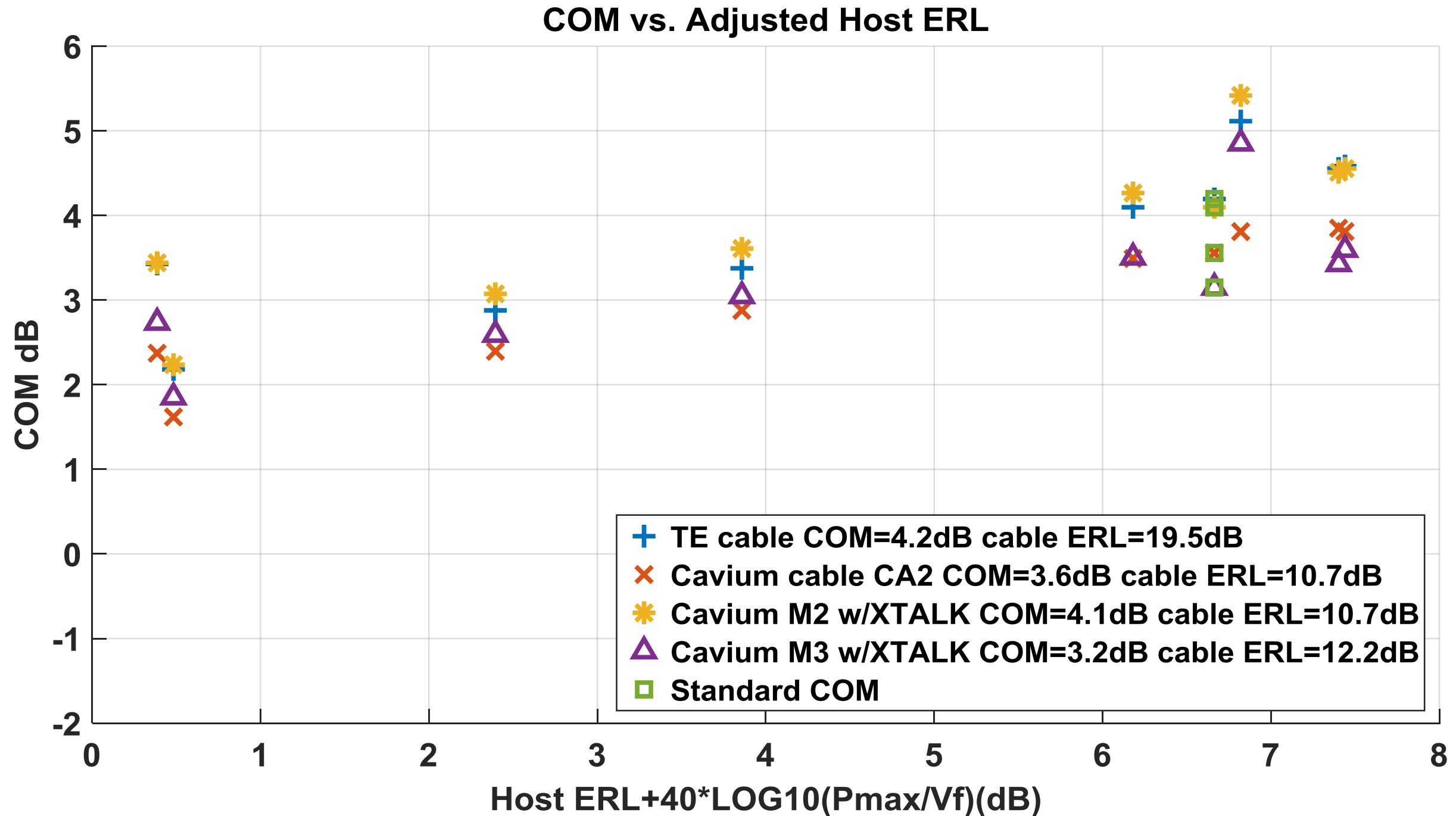

Conclusion and proposal.

- **The host with approximately the same Pmax and Vf but with better SNR_{isi} performed significantly better with all the cables, however it is still significantly worse than the standard COM transmitter.**
- **Either**
 - Change the host pass/fail criterion to

$$ERL \geq 40 \log_{10} \left(\frac{v_f}{\max_k (p(k))} \right) + 3 \quad \text{dB}$$

- **Or**
 - Add an additional transmitter specification

$$\text{SNR}_{\text{isi}} \geq 40 \log_{10} \left(\frac{v_f}{\max_k (p(k))} \right) + 31 \quad \text{dB}$$



Back-up

Additional host with lower SNR_{isi} but similar P_{max}/V_f and ERL

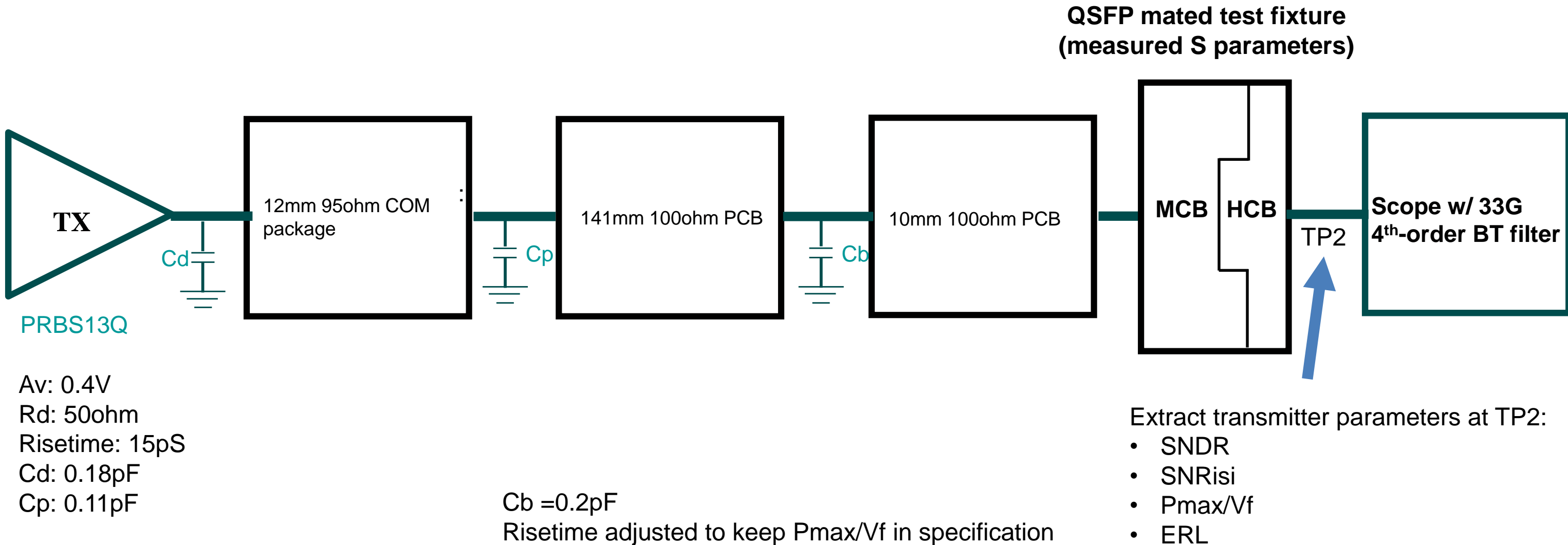

COM vs. Host ERL (D3.3) All points meet Pmax/Vf spec

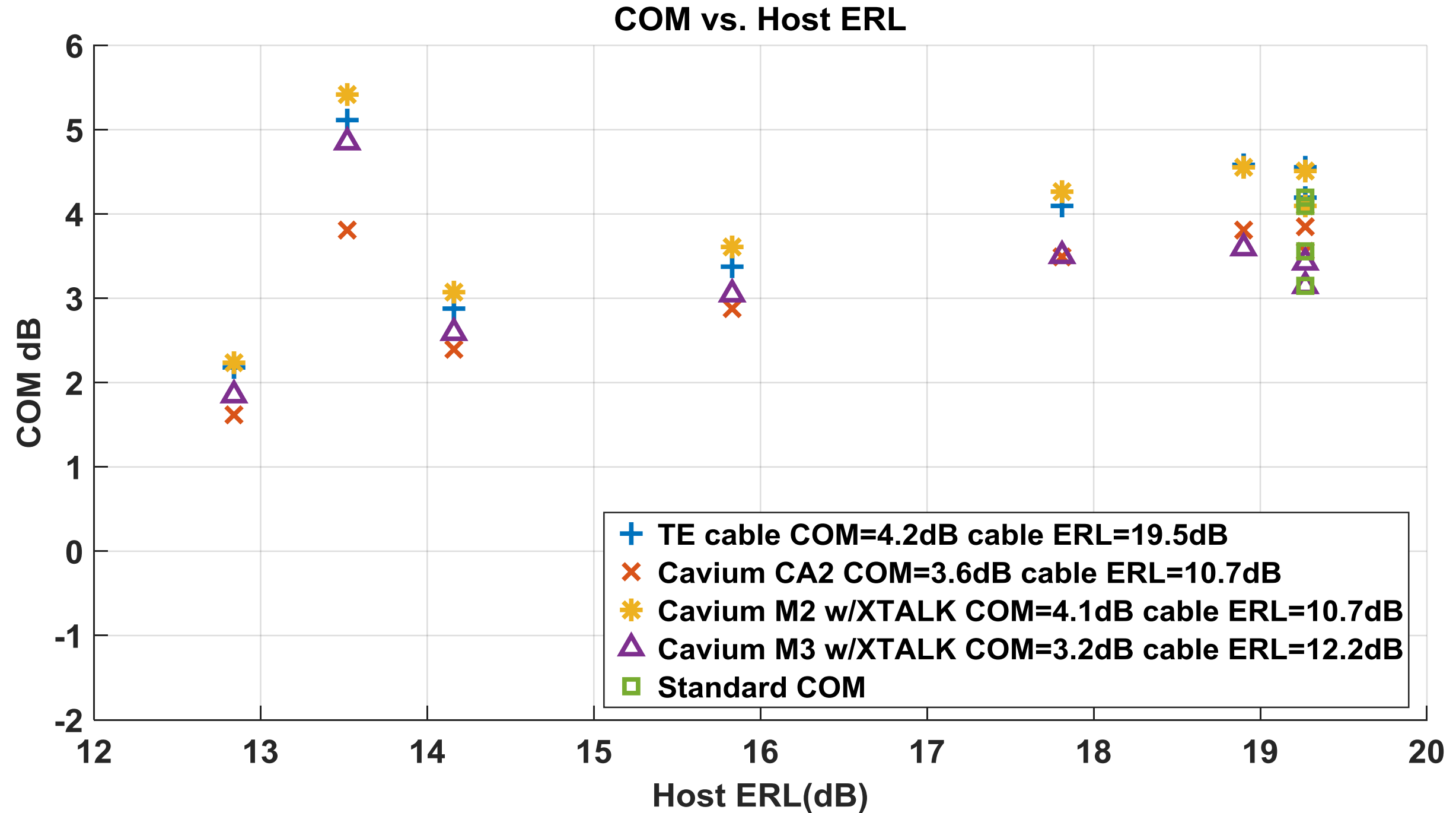



Host Rx comments.

Comments on host Rx.

- **Degradations caused by reflections within the host Rx are present during the interference tolerance test therefore they have to be compensated by the receiver having better other performance. (e.g. can work with lower COM).**
- **The improved Rx performance required for reflections within the host Rx is somewhat similar to requiring higher P_{max}/V_f when the ERL is poorer.**
- **ERL is required to limit reflections from the host Rx that are re-reflected by the cable.**
- **Simulations have shown that the draft 3.3 ERL limits for the Rx and the cable do not create a large inter-operability risk and therefore no comment was made to change this limit.**



Cable creation.

Block diagram of cable assembly CaviumCA2

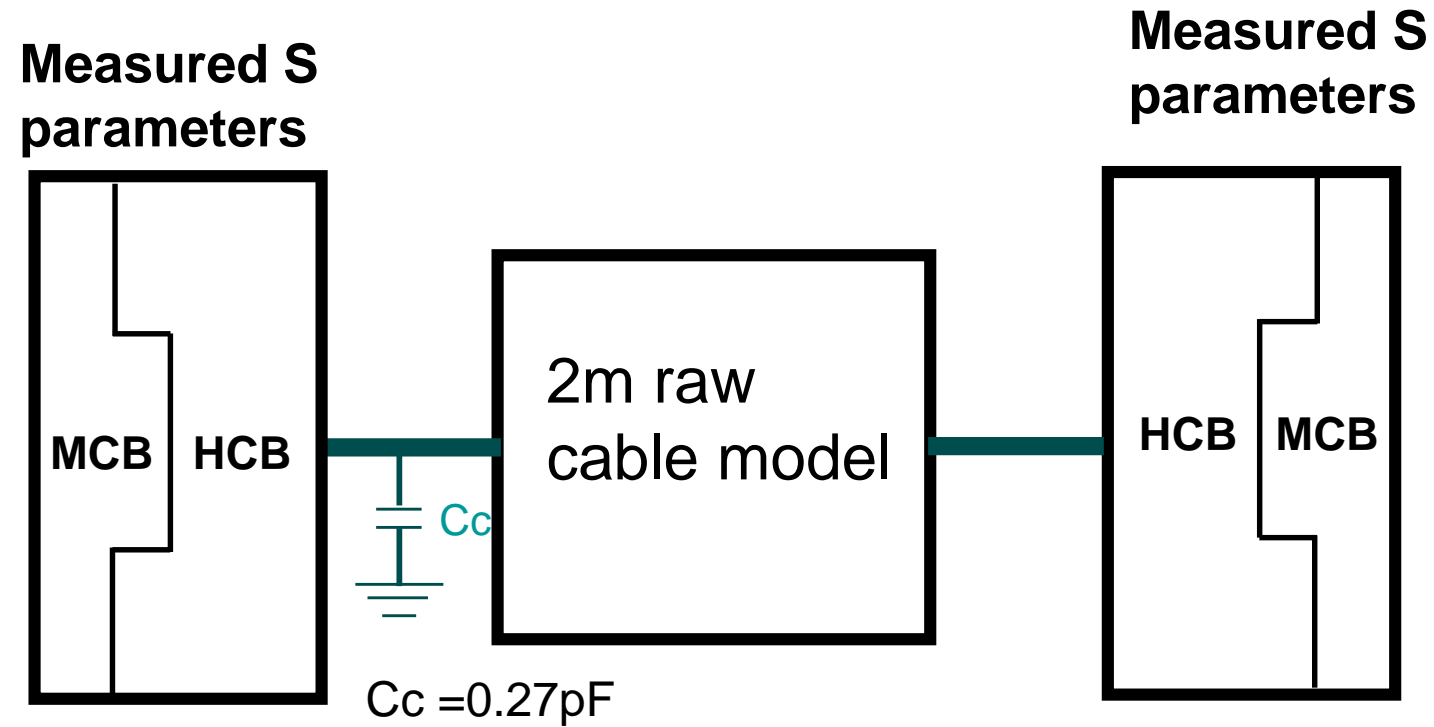

The raw cable model uses the transmission line model in Clause 93A with parameters provided by Rich Mellitz for a 26AWG cable.



Cable Frequency Domain Performance

TE cable

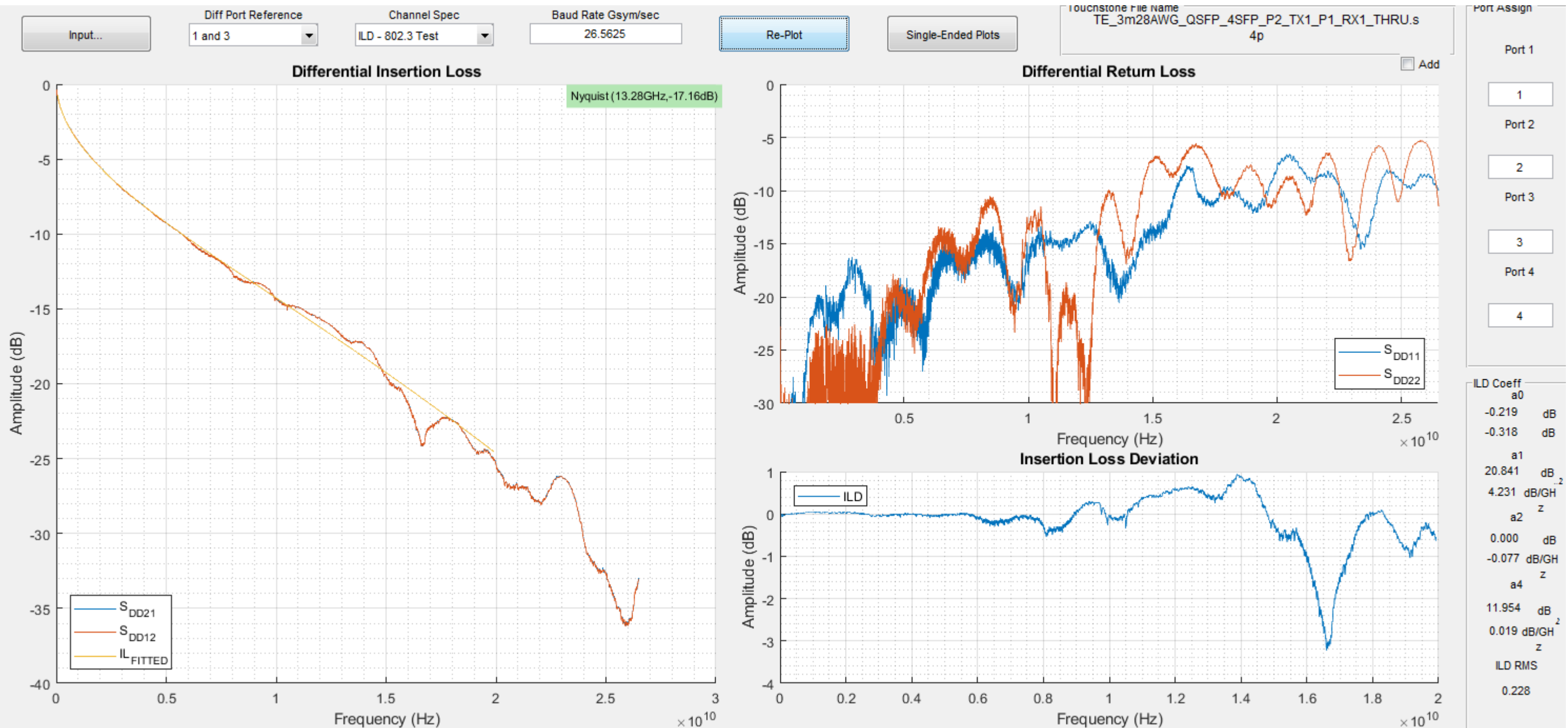

Cavium CA2 cable

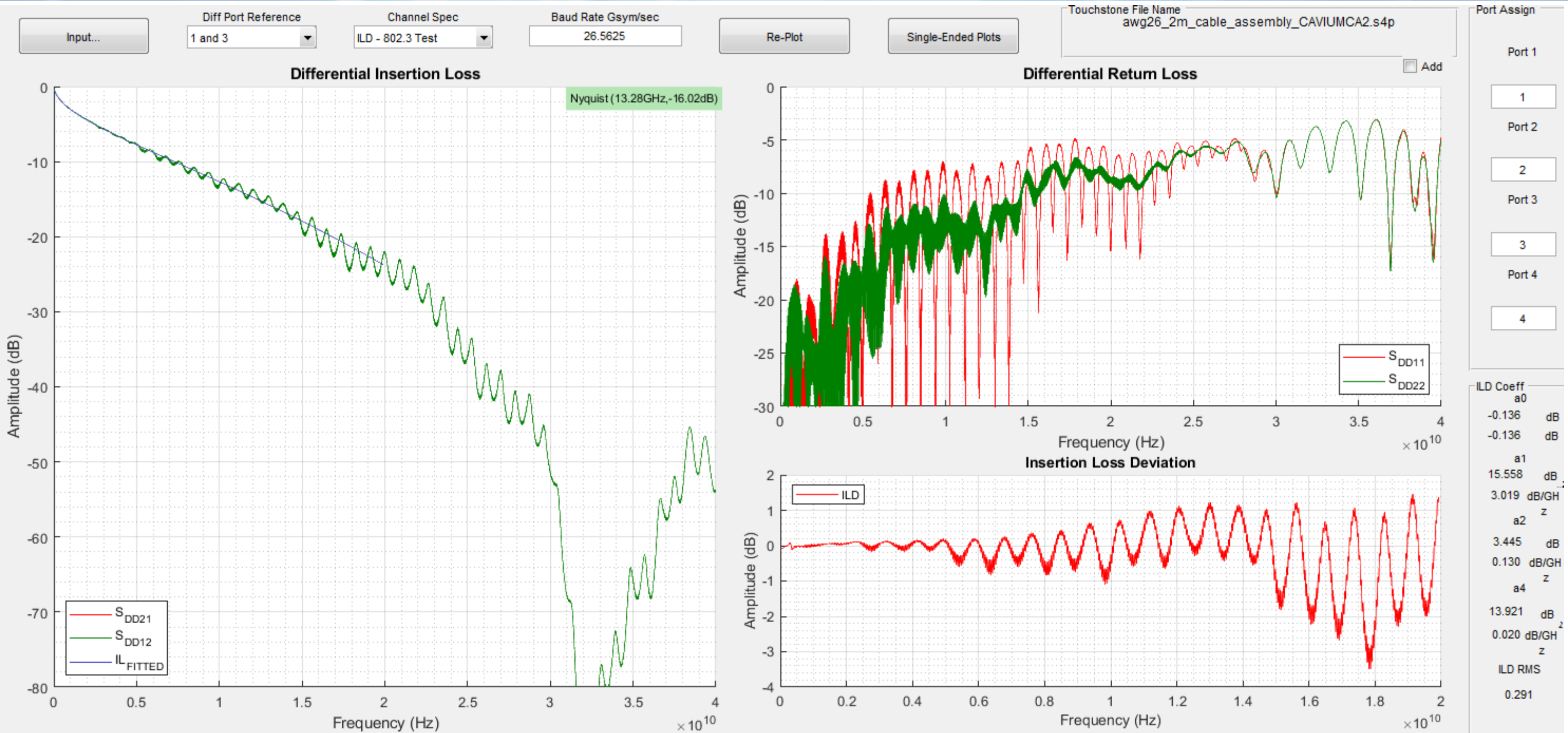

CaviumCA2 cable (ERL 10.7dB using new parameters) comparison to draft 3.2 informative return loss 92.10.3.

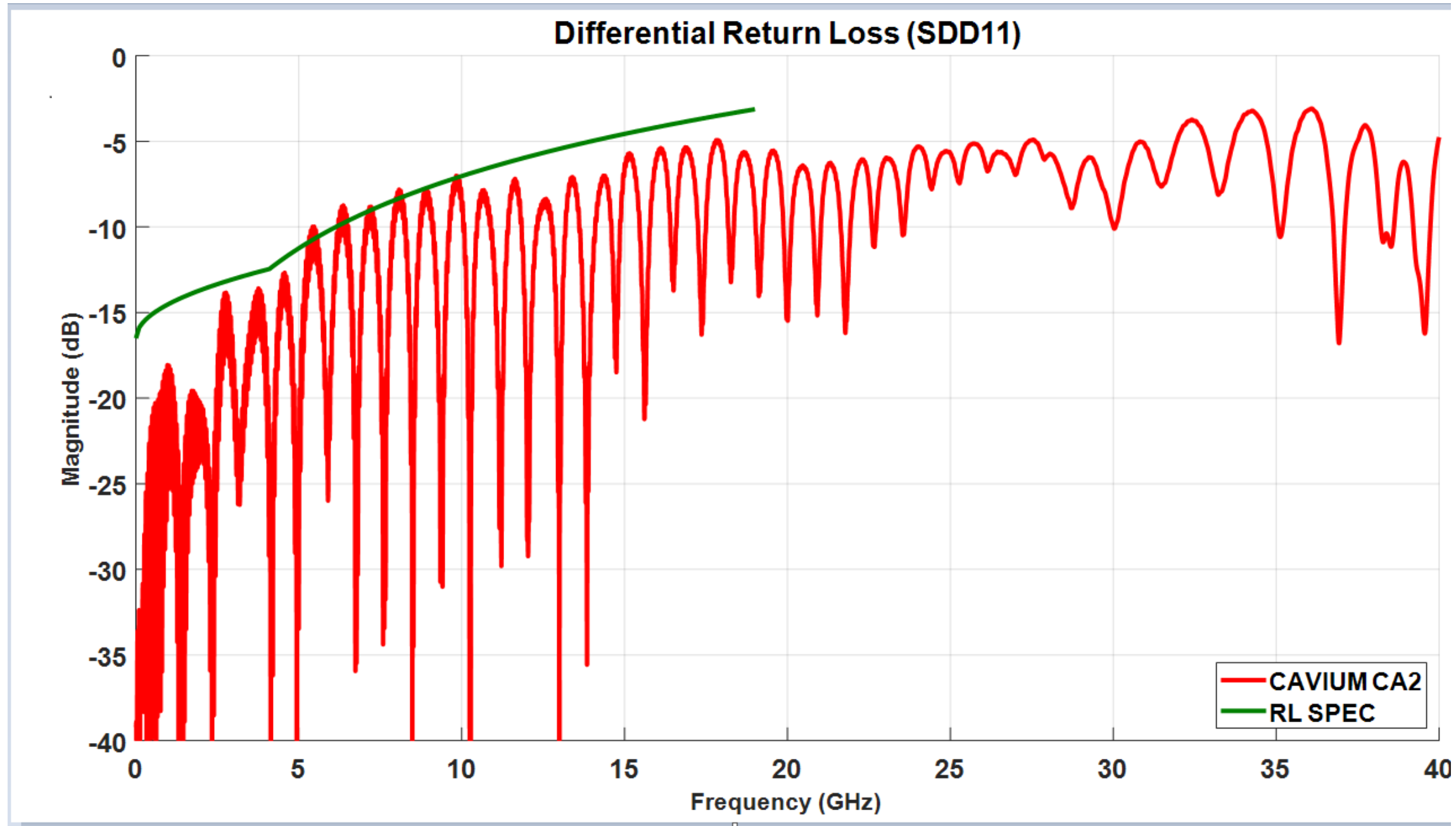

Cavium M2 cable

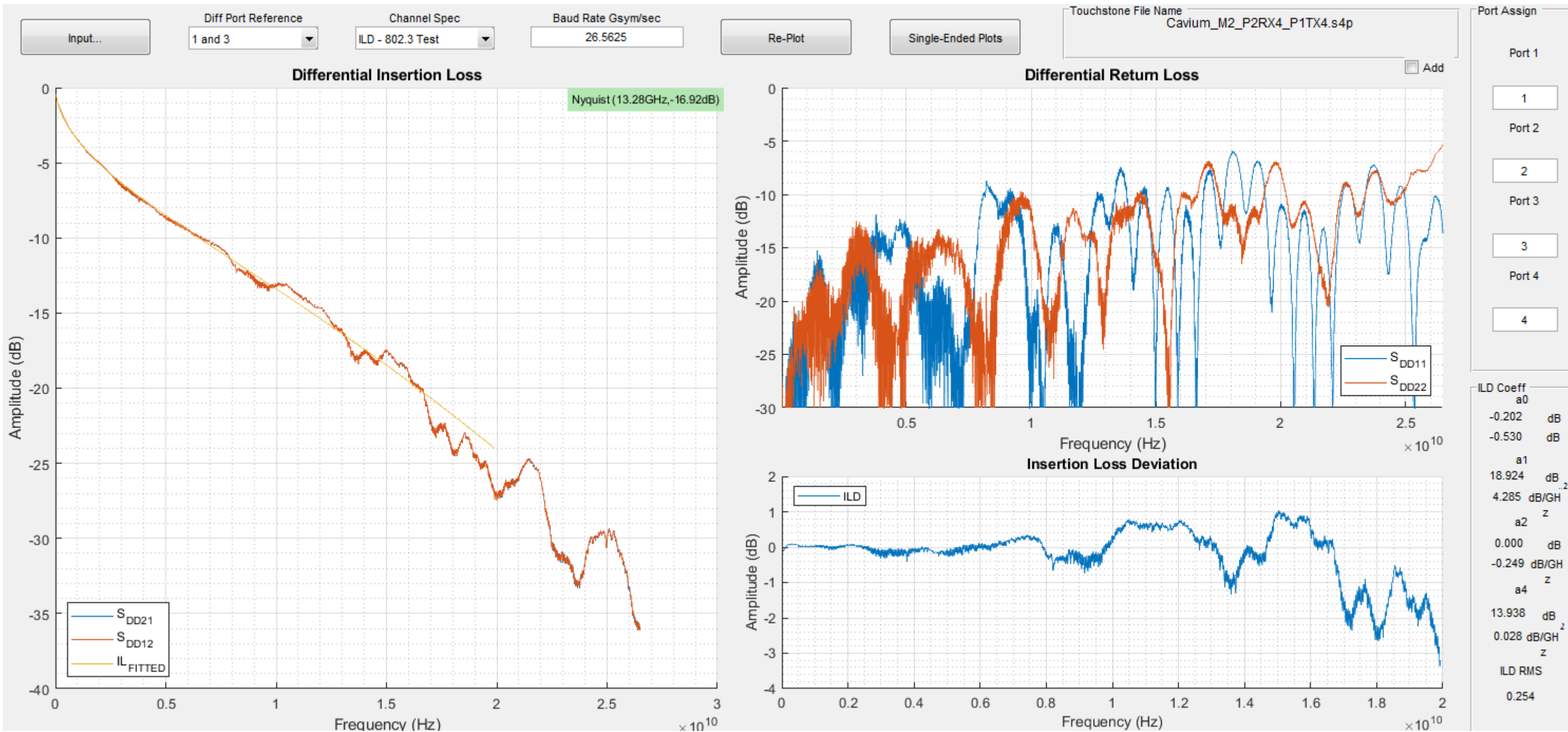

Cavium M3 cable

