

IEEE P802.3cg

Mixing Segment Node Loading

David D. Brandt, Rockwell Automation

Scott Griffiths, Rockwell Automation

Purpose

- The purpose of this presentation is to:
 - Follow-up in more detail on initial estimation:
 - “Multidrop PHY Simulation”
 - http://www.ieee802.org/3/cg/public/July2017/brandt_cg_03_0717.pdf
 - Examine the effect of the loading presented by a node on the IEEE P802.3cg mixing segment
 - Consider large node count
 - Propose a per-node load budget

Agenda

- Potentially relevant multidrop clauses
- External multidrop example
- Spice modeling methodology
- Spice modeling results
- Conclusions and followup

POTENTIALLY RELEVANT MULTIDROP CLAUSES

Multidrop “copper” clauses

	Clause 8	Clause 10
Rate	10 Mb/s CSMA/CD	10 Mb/s CDMA/CD
Mixing segment	500 m, coaxial	185 m, coaxial
Maximum MAUs	100	30
Input impedance	≤ 4 pF ≤ 50 m Ω (series) > 100 k Ω (parallel) Power-off and power-on, not transmitting	≤ 8 pF $\leq ??$ m Ω (series) > 100 k Ω (parallel) Power-off and power-on, not transmitting
Cable impedance	50 Ω +/- 2 Ω , average	50 Ω +/- 2 Ω , average
End terminations	50 Ω +/- 1%, resistive	50 Ω +/- 1%, resistive
Stubs	3 cm max., recommendation	4 cm max., recommendation
Cable section and placement rules	<ul style="list-style-type: none"> Lengths are odd multiples of half wavelength <ul style="list-style-type: none"> $V_p = 0.77 c$ Reflections less than 7% of incident wave 	<ul style="list-style-type: none"> 0.5 m minimum cable section 0.5 m minimum MAU spacing

Thoughts on Clauses 8 and 10

- Clauses do not directly apply
 - Maintenance is no longer allowed
 - Different impedance
 - No provision for power
 - Shielded system, different EMC environment
 - Not for a balanced pair
- They provide concepts on how to specify a multi-drop media system

EXTERNAL MULTIDROP EXAMPLE

IEC 6206-2 (AS-i)

- Successful balanced pair multidrop communication network with power
- Sets RLC limits for master, slave, power supply

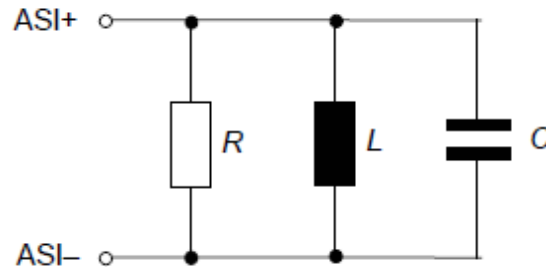

Equivalent circuit of a slave for frequencies in the range of 50 kHz to 300 kHz

R (k Ω)	L (mH)	C (pF)
> 8 k Ω	> 9 mH	< 100 pF
> 13,5 k Ω	> 13,5 mH	< 50pF

Can this simple concept be applied?

SPICE MODELING METHODOLOGY

LTSpice XVII modeling

- 25 m bus length
- 40 nodes
- +/- 1 V at transmitter → 1 V_{pp} on bus
- No Spice simulation of bus power
- Ideal transmission line, $V_p = 0.66 c$
- Model based on real components, but simplified where possible
- 16-bit signal pattern: 0101 0011 0000 1111
- Initial 10 k and 500 u (470 u) taken from draft

Example mixing segment sub-circuits

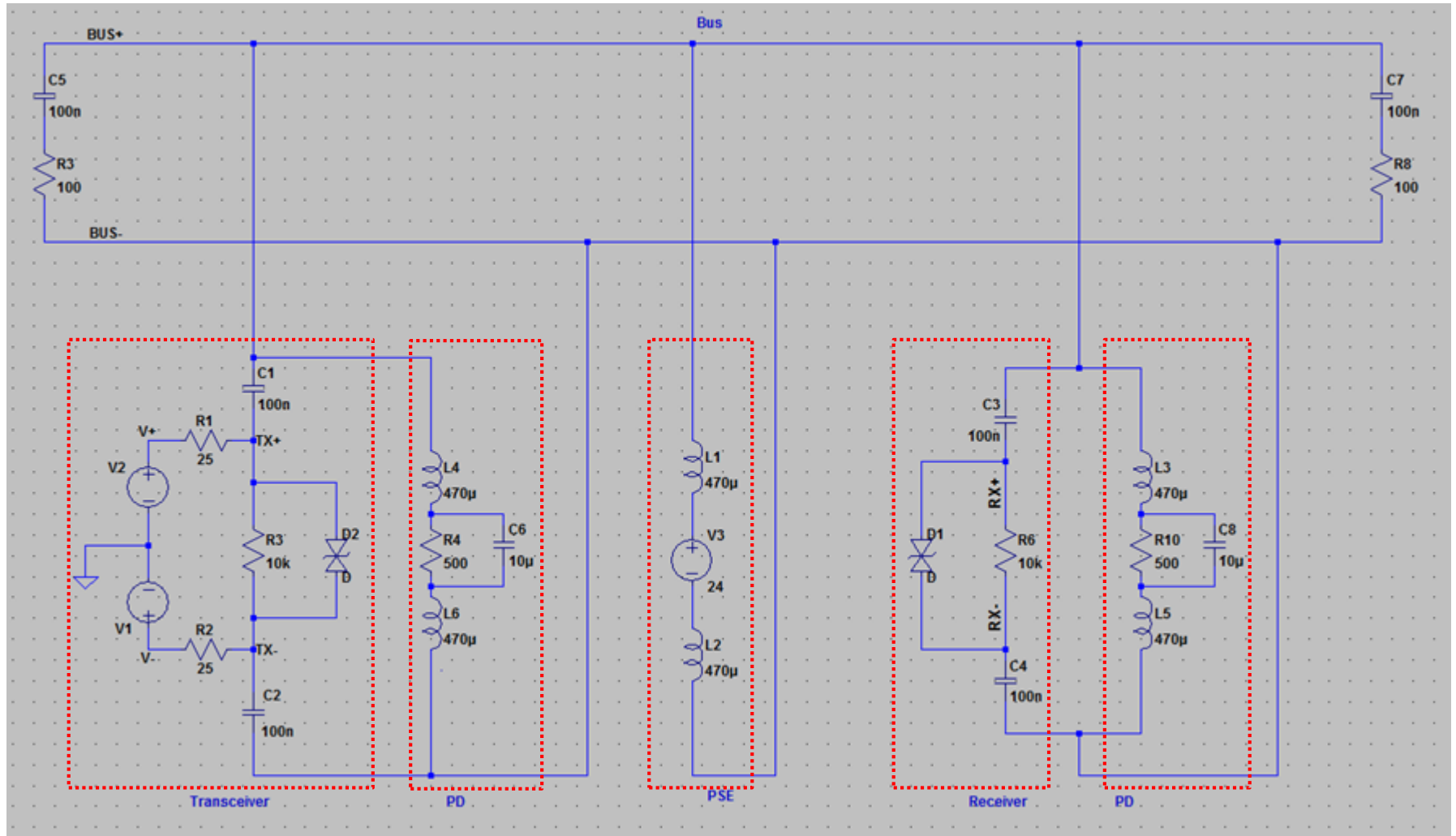

Non-ideal component LTSpice models

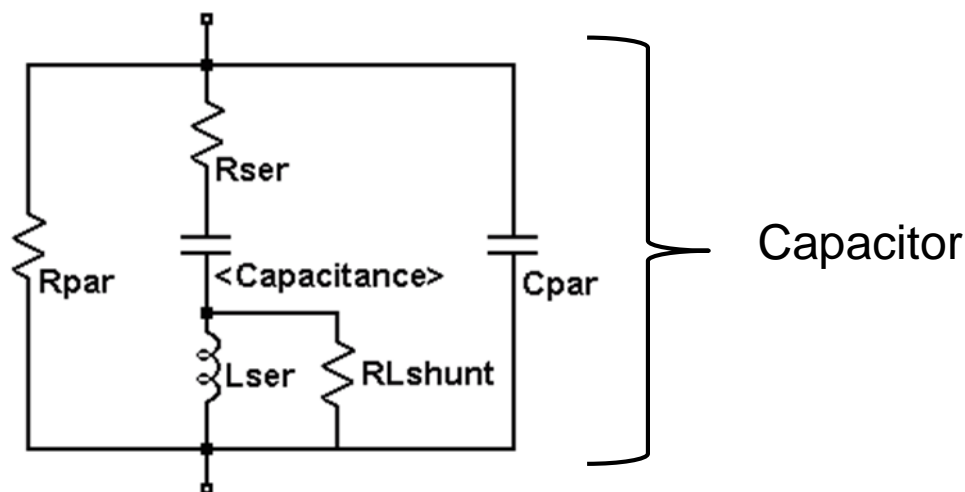
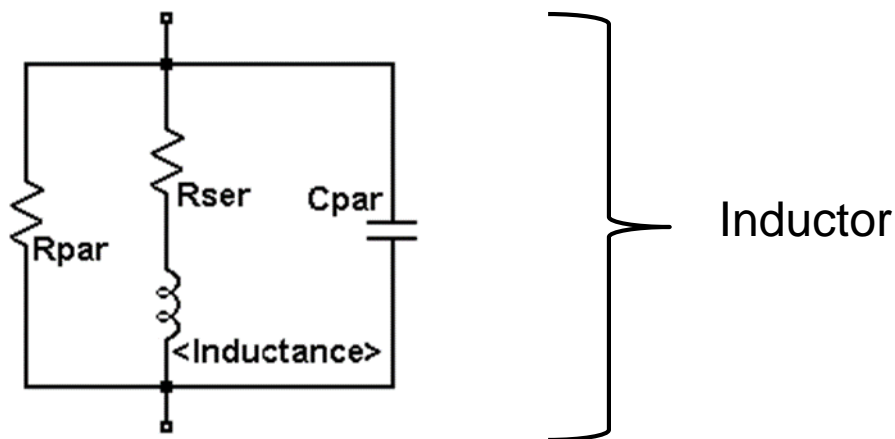

- Resonance may fall into our communication band
 - PSE and PD inductors consider non-ideal model
 - Transceiver coupling capacitors consider non-ideal model

TVS

100BASE-T1 Example

- IEC 61000-4-2 Level 4 ESD protection
 - ± 12 kV contact discharge
 - ± 15 kV air gap discharge
- IEC 61000-4-4 EFT protection
 - 80 A (5/50 ns)
- IEC 61000-4-5 surge protection
 - 2 A (8/20 μ s)
- IO capacitance: 0.27 pF (Typ), 0.37 pF (Max)
- DC breakdown voltage: 5.5 V (Min)

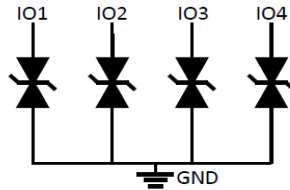

More harsh environment

- ESD, IEC 61000-4-2, ± 30 kV contact, ± 30 kV air
- EFT, IEC 61000-4-4, 40A (5/50ns)
- Lightning, IEC 61000-4-5, 25A ($t_p=8/20\mu$ s)
- Low capacitance of 2.5pF (@ $V_R=0V$)

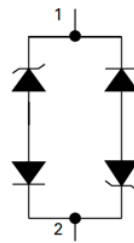

- Protects against ESD, EFT, and Surge
- Acts as capacitor when not conducting
- Higher speed communication has driven low capacitance designs
- Capacitance increases with larger surge requirement

Stubs

- We can calculate the per unit length parameters for a lossless line by solving for L and C, assuming the stub is electrically short (wavelength of 12.5 MHz at 0.66 c is 16 m)
 - $Z_0 = \sqrt{L/C}$
 - $V_p = 1/\sqrt{L \cdot C}$
- Parameters:
 - 2 cm stub = 1 pf, 10 uH
 - 10 cm stub = 5 pf, 50 uH
- Capacitance is seen across line
- Small inductance filters communication
- Poor design could achieve much worse results

Simplification of Receiver and PD

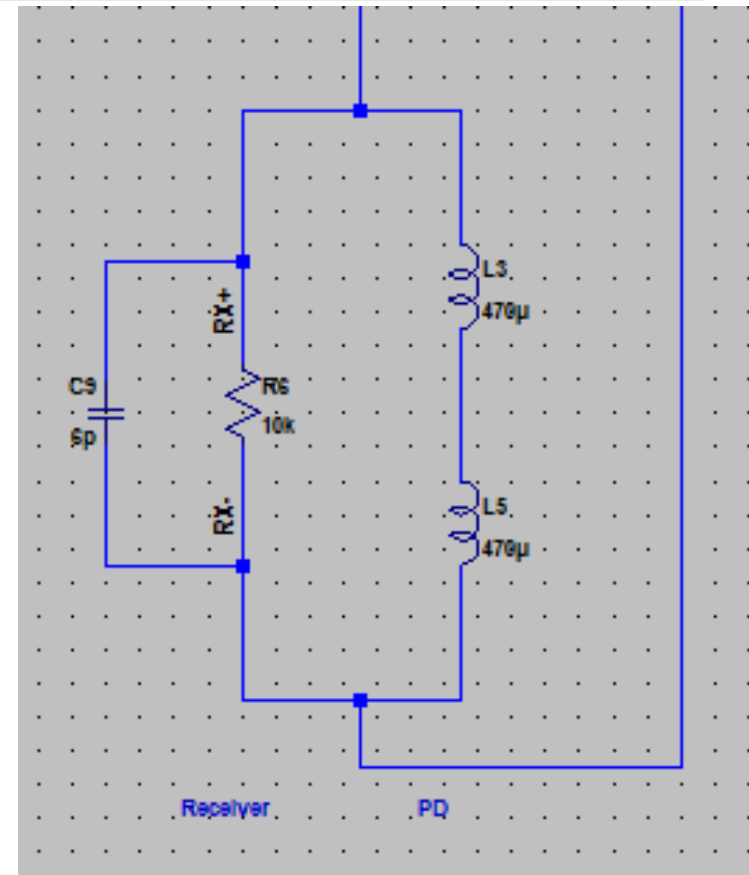
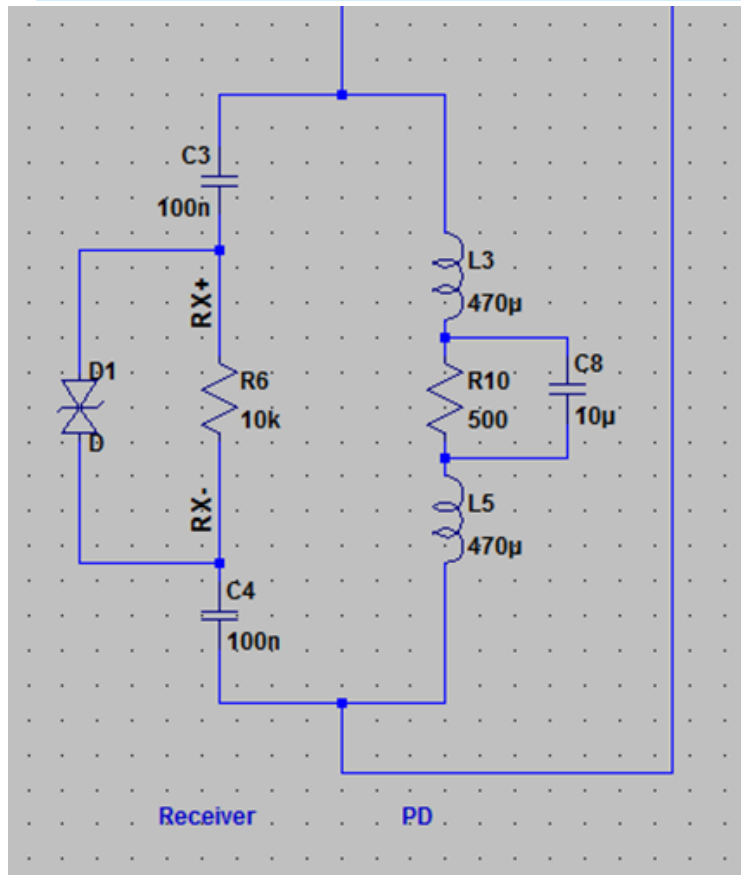

Receiver + PD loads end up looking like RLC across the line

First model: lumped RLC

- Determine initial values for R, L, and C based on a 40 node example system
- Test sensitivity to various positions
- Perform additional modeling with a more accurate distributed node model

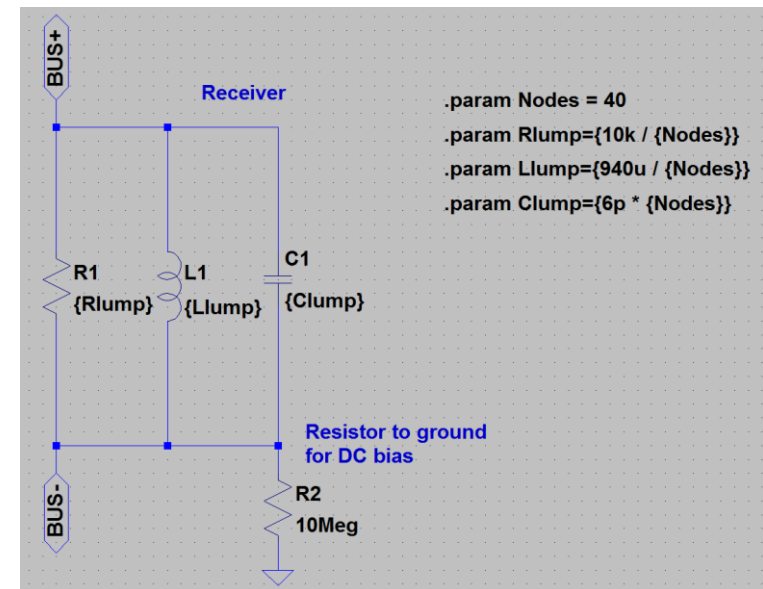
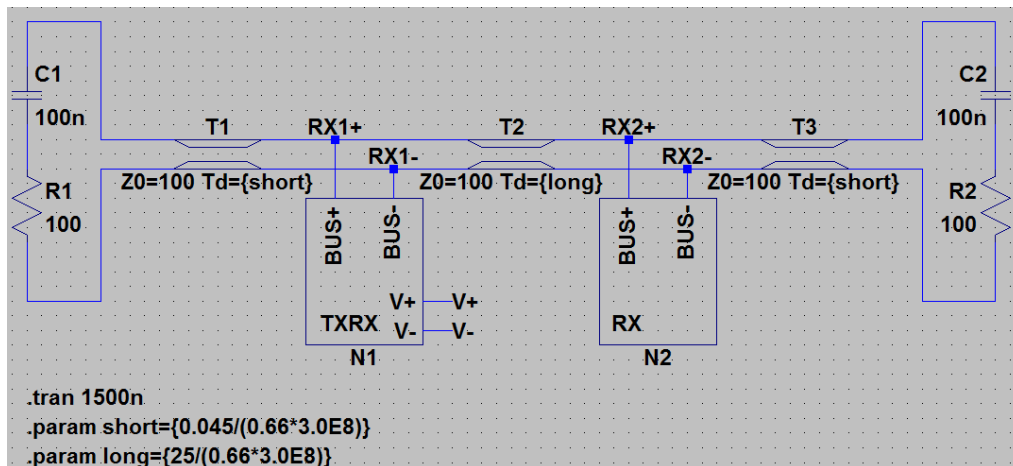

Worst case appears to be lumped load furthest from transmitter

Second model: distributed RLC

All nodes evenly spaced over 25 m

Lossless transmission lines interconnect nodes

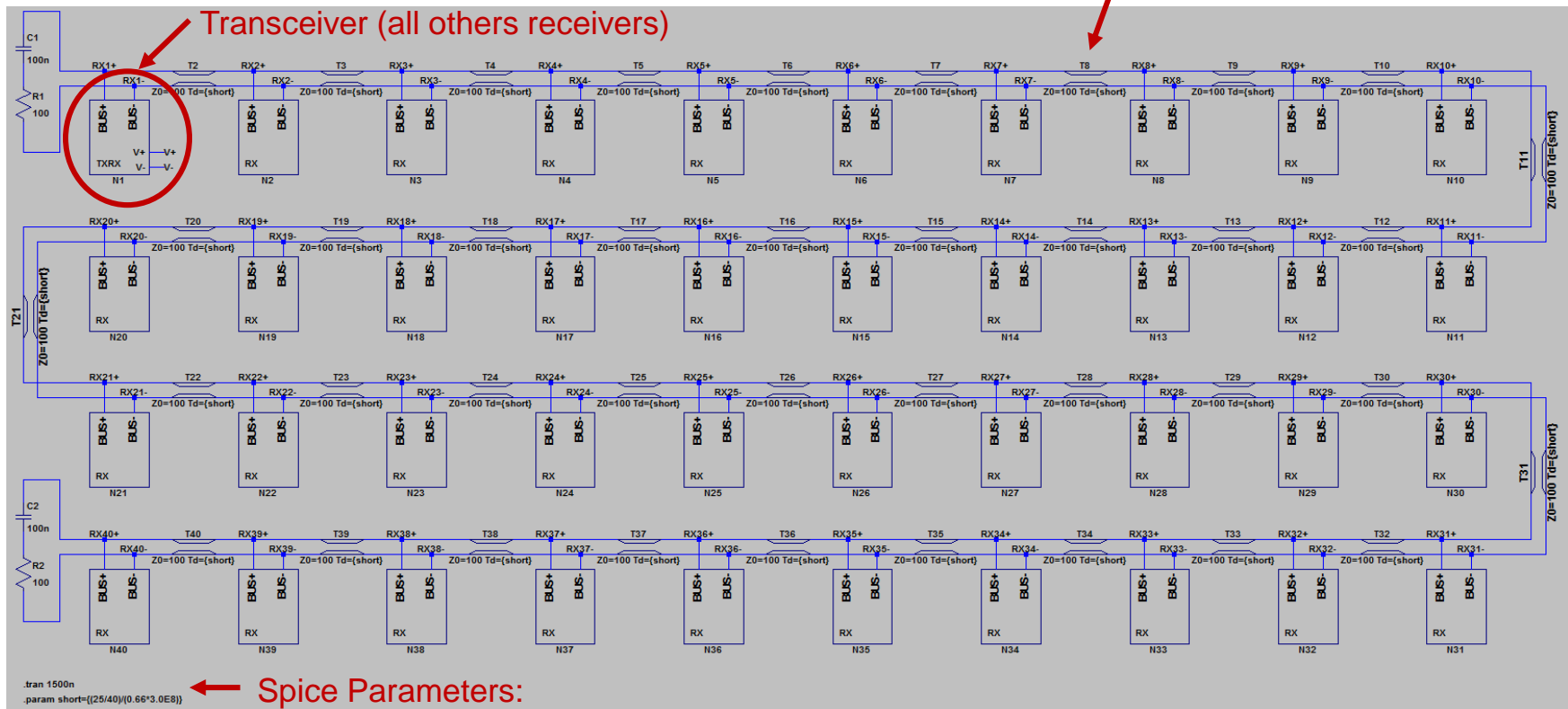

← Spice Parameters:

transient simulation, 1500 ns duration

transmission lines = 100 Ω impedance, 25 m / 40 length, $V_p = 0.66 c$

Transceiver and receiver models for distributed circuit

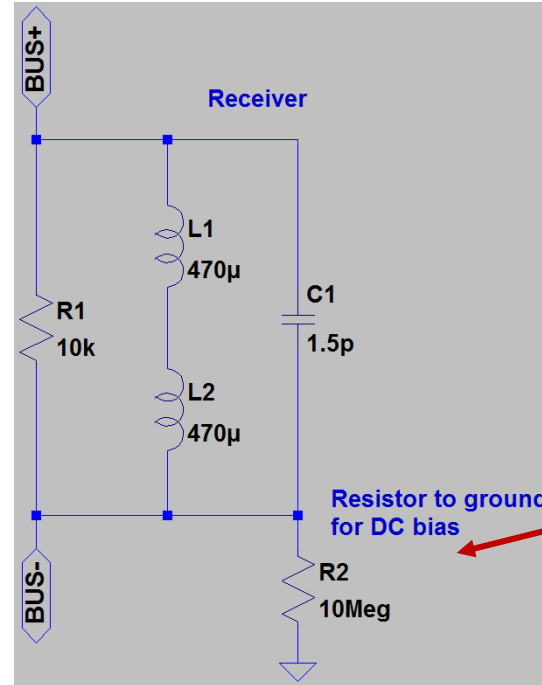
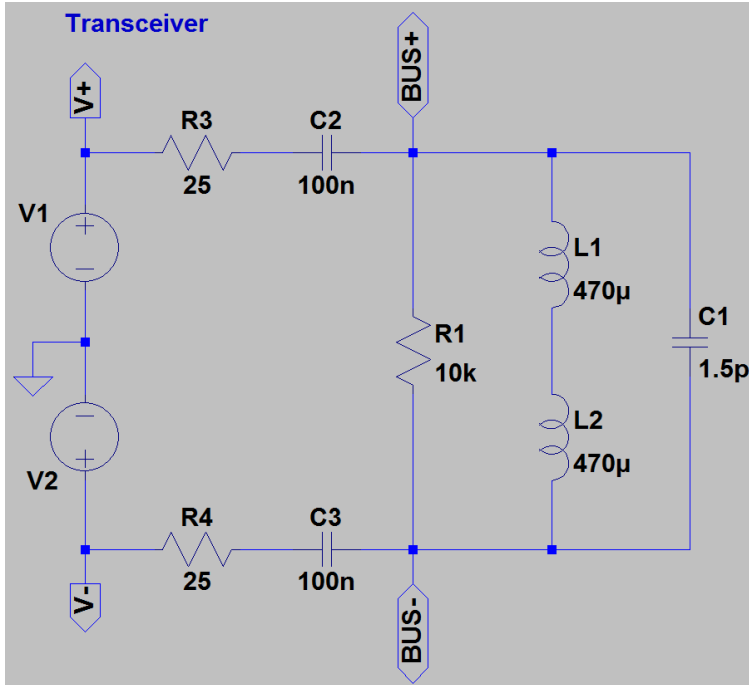

- C1 represents capacitance of TVS device
 - Inductors are non-ideal and cannot be combined
- R2 in receiver is for Spice convergence

100 nF capacitor parameters:
 ESR: 20 mΩ
 ESL: 0.77 nH

Inductor parameters:
 Series Resistance: 16.3 Ω
 Parallel Resistance: 2 MΩ
 Parallel Capacitance: 5.5 pF

All other components are ideal

DME stimulus

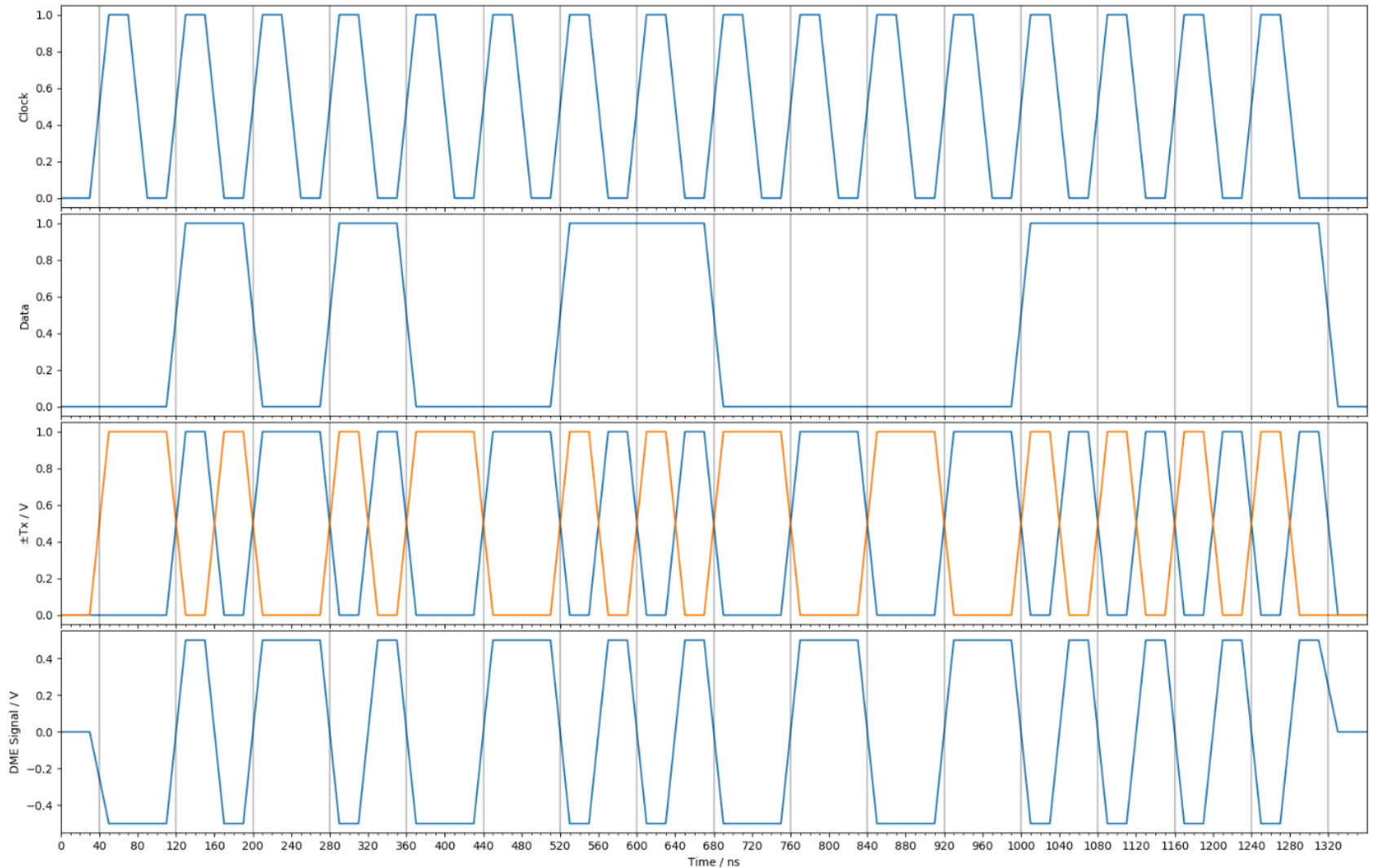

SPICE MODELING RESULTS

Resistor value dependence

- Resistors represent receiver circuit load
- Resistance closes eye diagram via attenuation
- Devices farther away from transmitter are attenuated more strongly

R = 20 k Ω

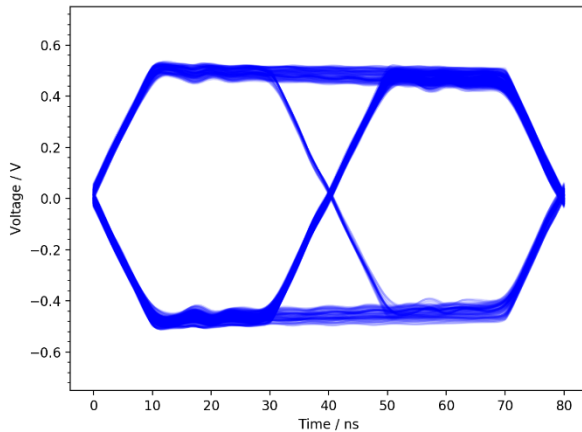

R = 10 k Ω (nominal)

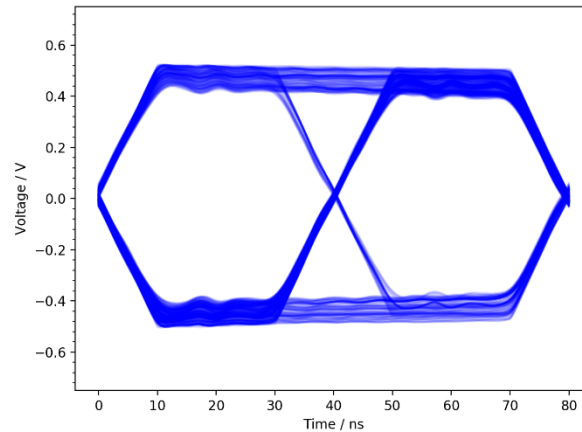

R = 5 k Ω

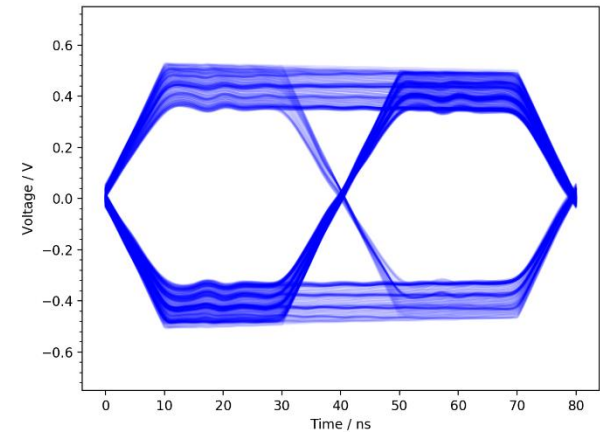

$R = 5 \text{ k}\Omega$
 $L = 940 \text{ }\mu\text{H}$
 $C = 1.5 \text{ pF}$

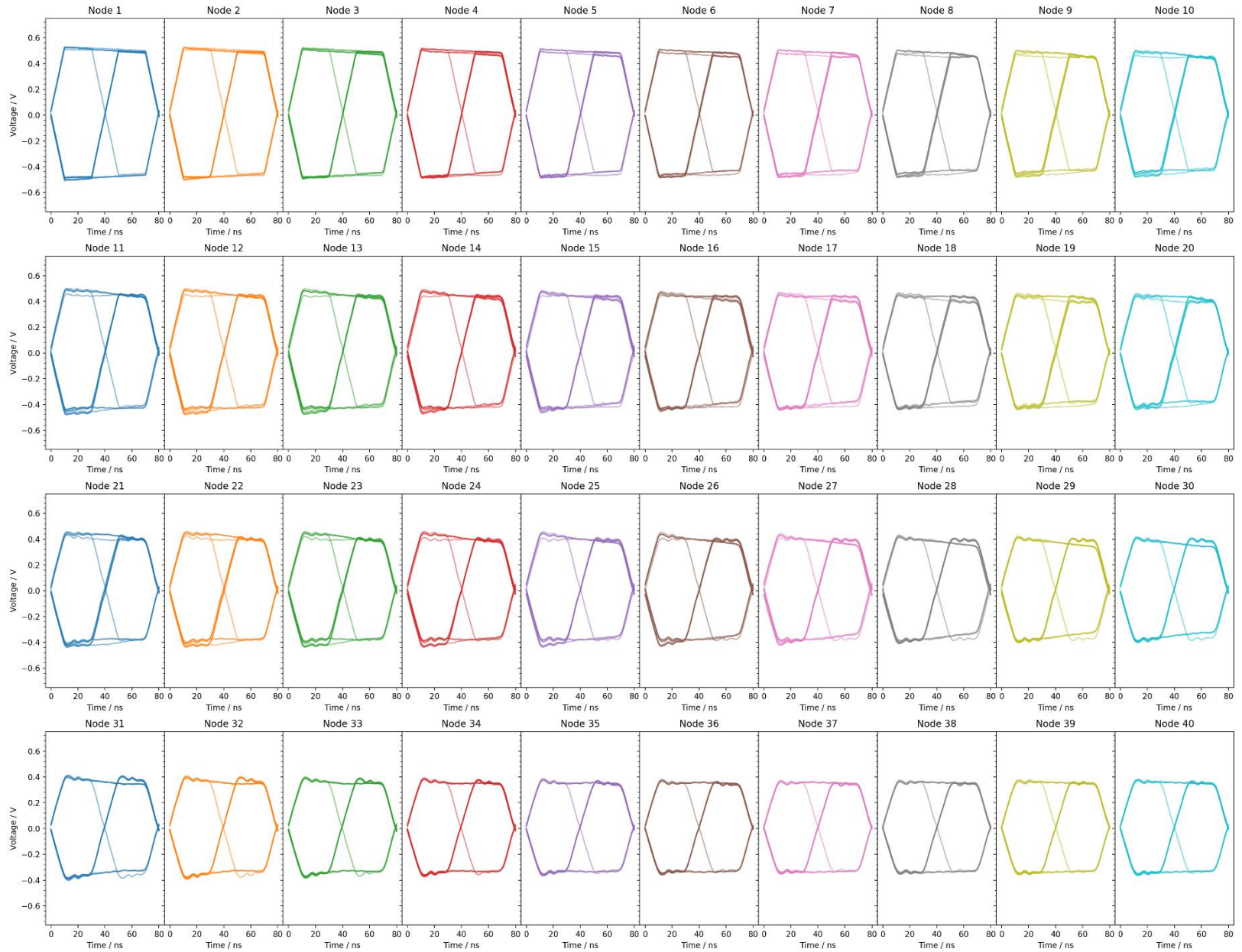

Inductor value dependence

- Inductors decouple node power supplies
- SRF of larger inductors may make them unusable
- Low inductance increases bit sag with increasing distance and may not block disturbances from inside the power supply

L = 9400 μ H

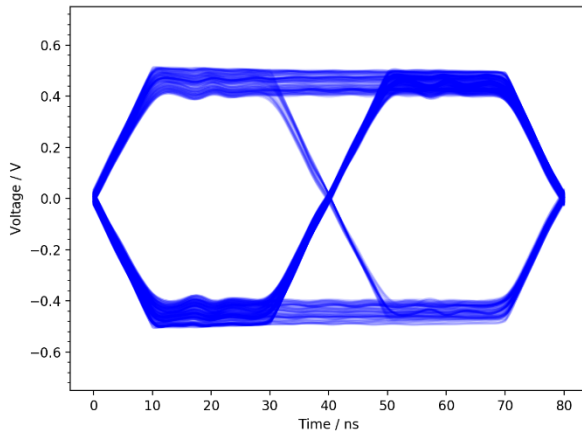

L = 940 μ H (nominal)

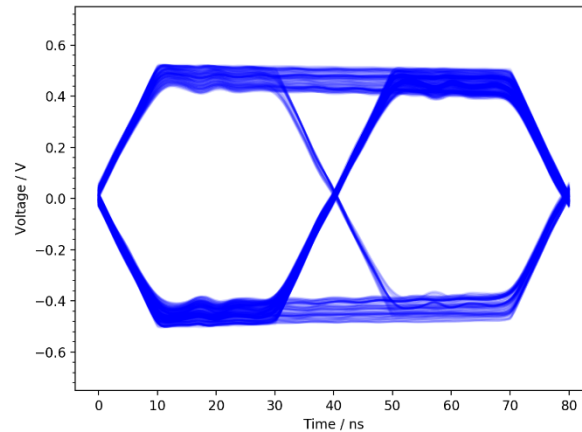

L = 94 μ H

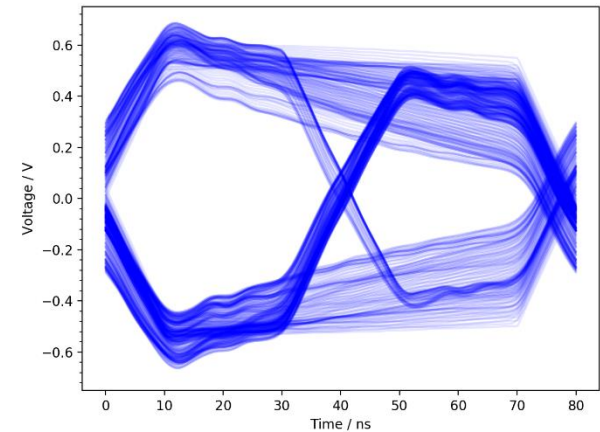

How small can the inductors be?

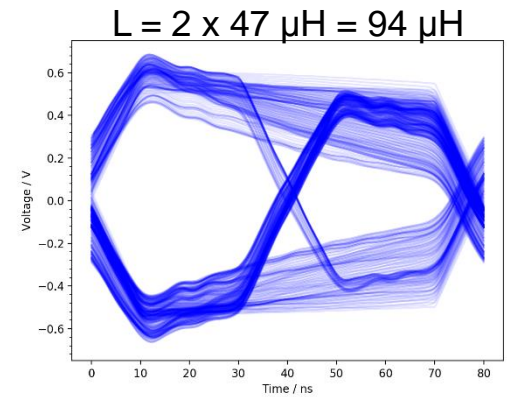
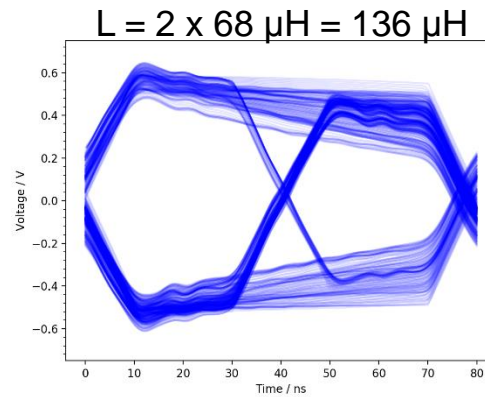
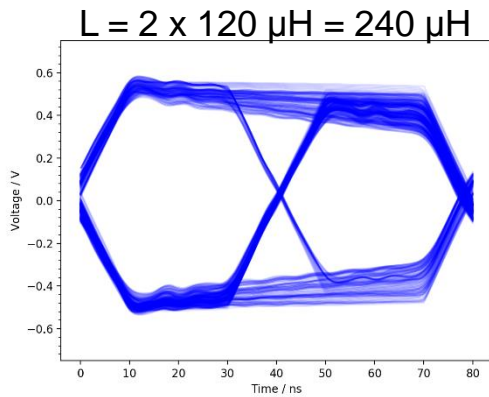
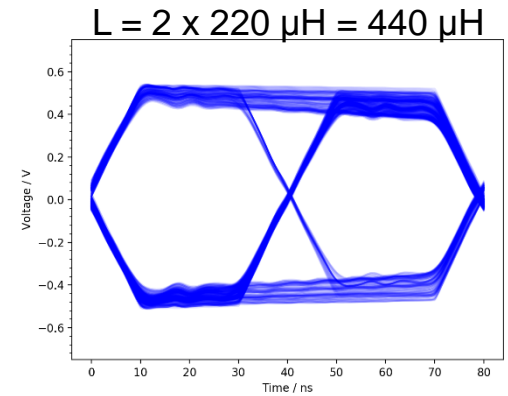
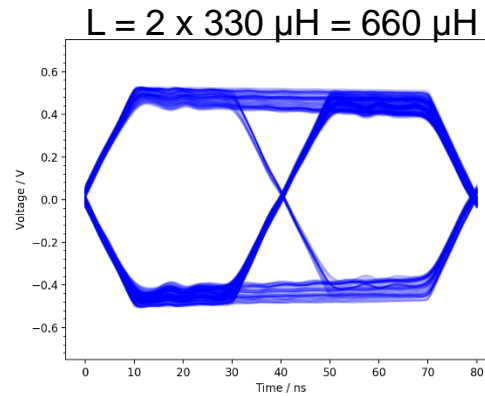
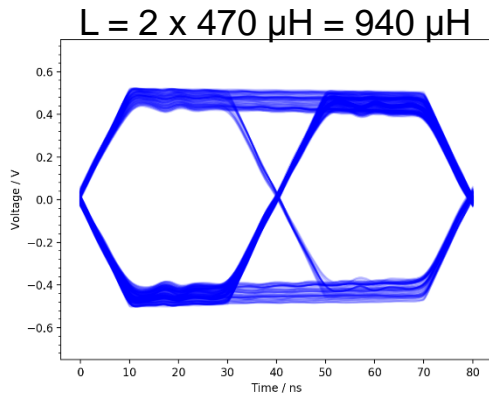

$R = 10 \text{ k}\Omega$
 $L = 240 \text{ }\mu\text{H}$
 $C = 1.5 \text{ pF}$

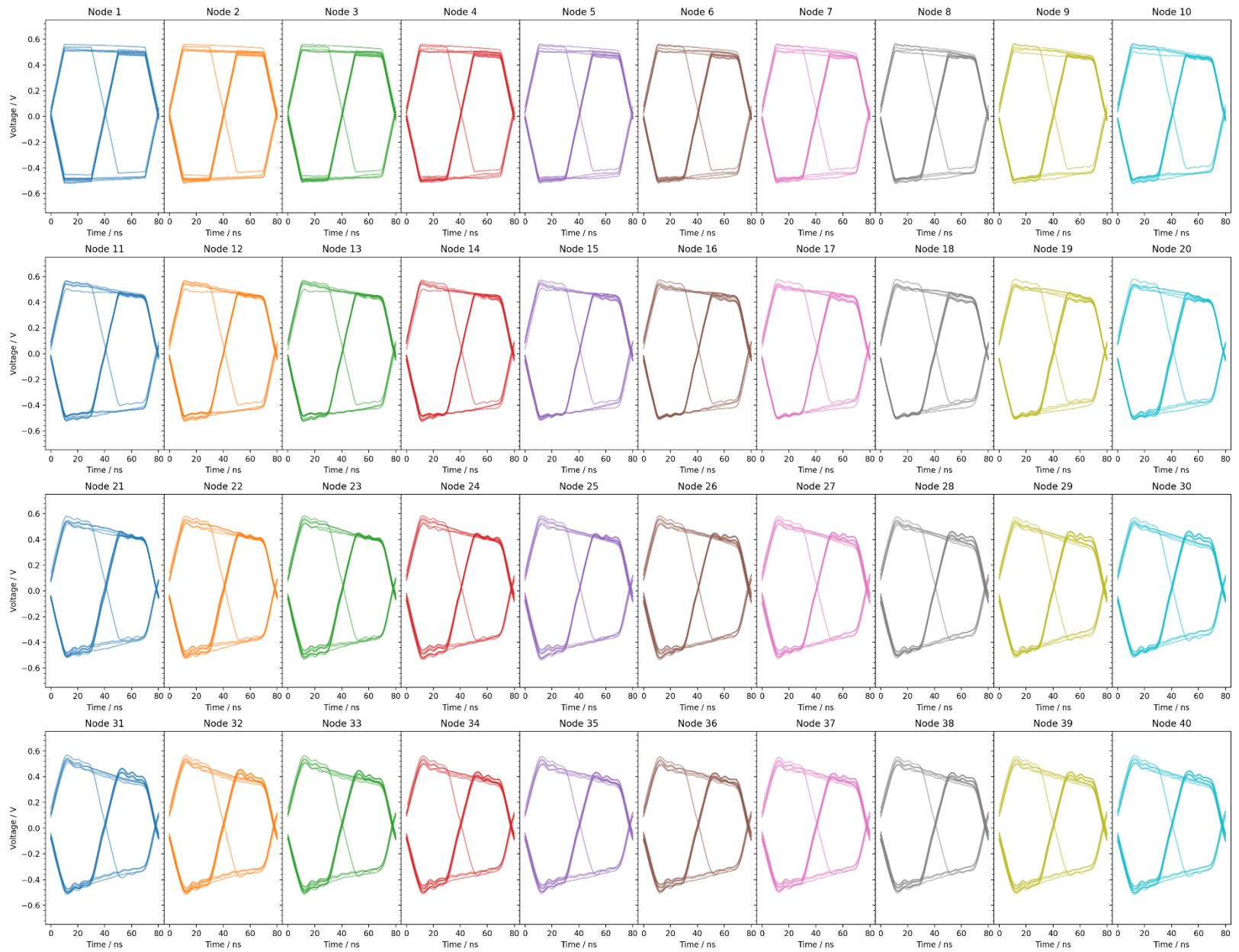

Inductor filtration of power disturbance

- In addition to node loading, we need to consider the filtering ability of the inductors
- We simulated sinusoidal noise injection for “real” inductors

	Rser (Ω)	Rpar (k Ω)	Cpar (pF)
4700u	13.9	148	539
820u	26.0	348	13.7
680u	24.0	587	6.0
560u	18.1	542	5.8
470u	16.3	504	5.6
330u	11.5	433	5.3
220u	10.0	380	4.6
120u	5.8	238	4.3
68u	3.8	231	2.6
47u	2.5	252	1.5

Real inductor parameters added to LTSpice model

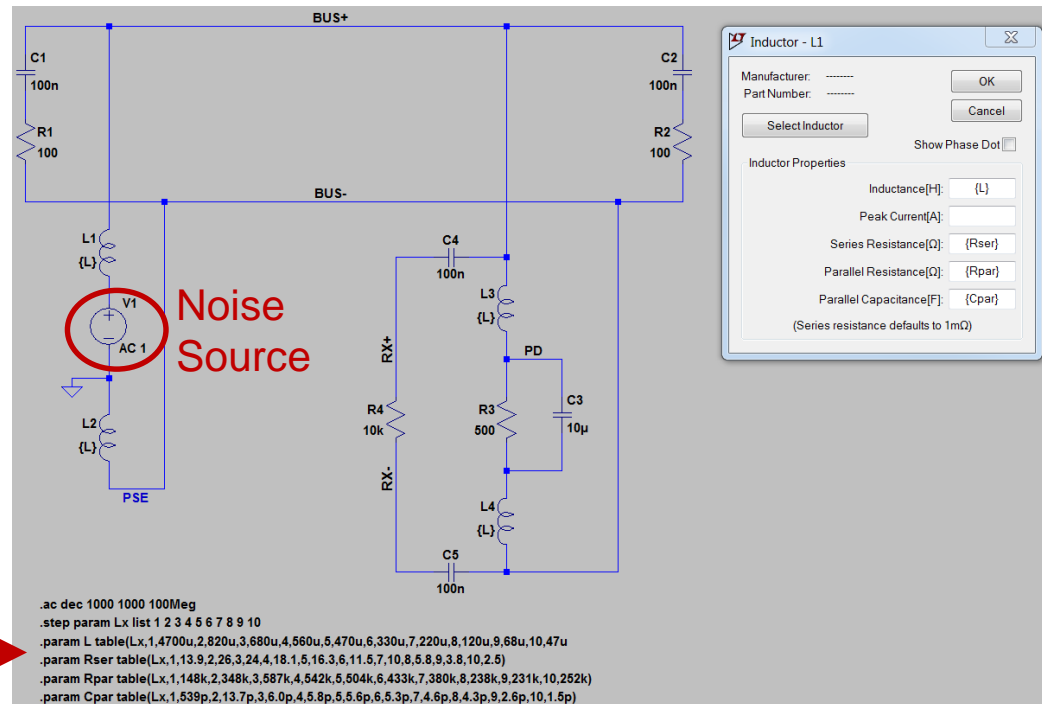

Inductor filtration of power disturbance

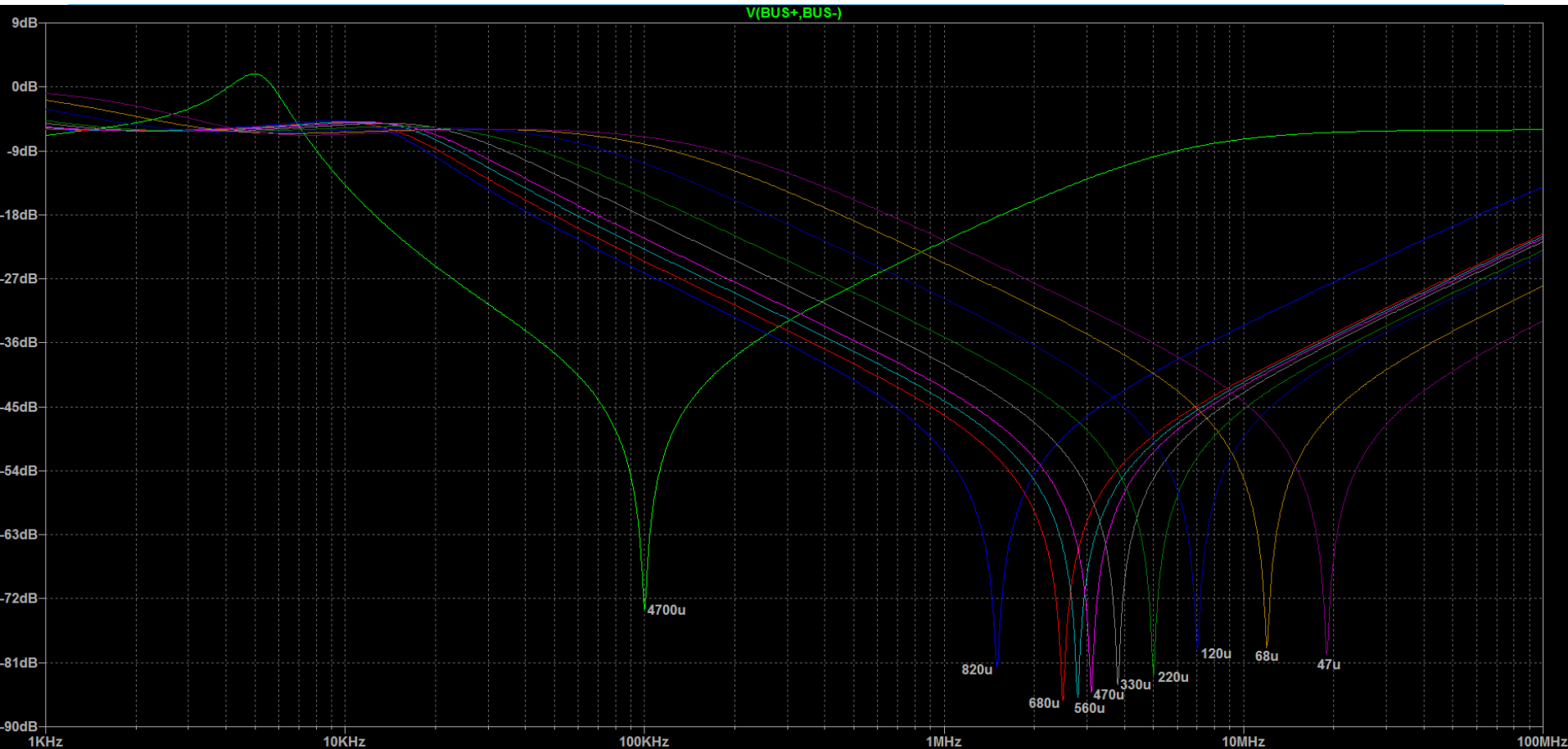

- Inductor values should be chosen to filter anticipated power supply switching frequency (4700 μ H not suitable)

Coupling through capacitor of transmit signal

- 100 nF capacitors on transmitter create a high-pass filter

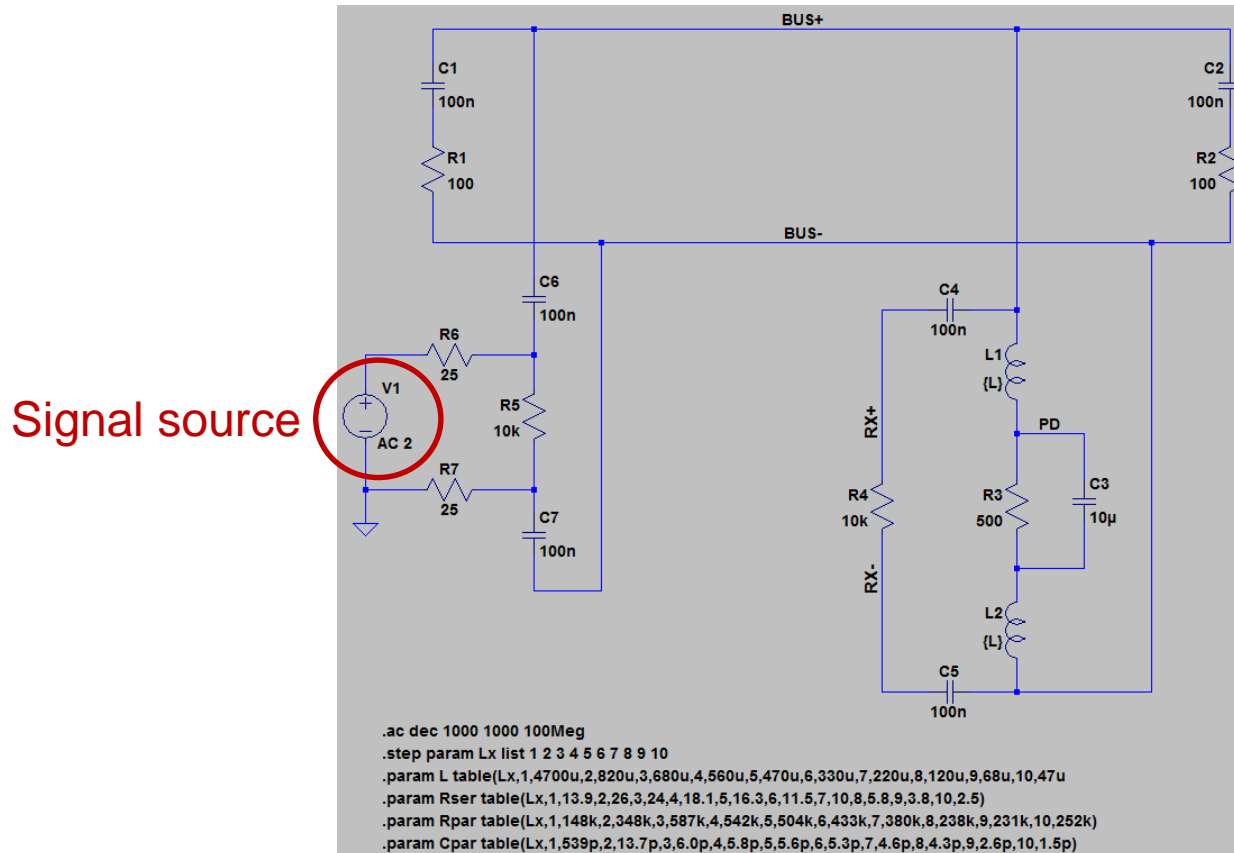

Capacitor signal filtration

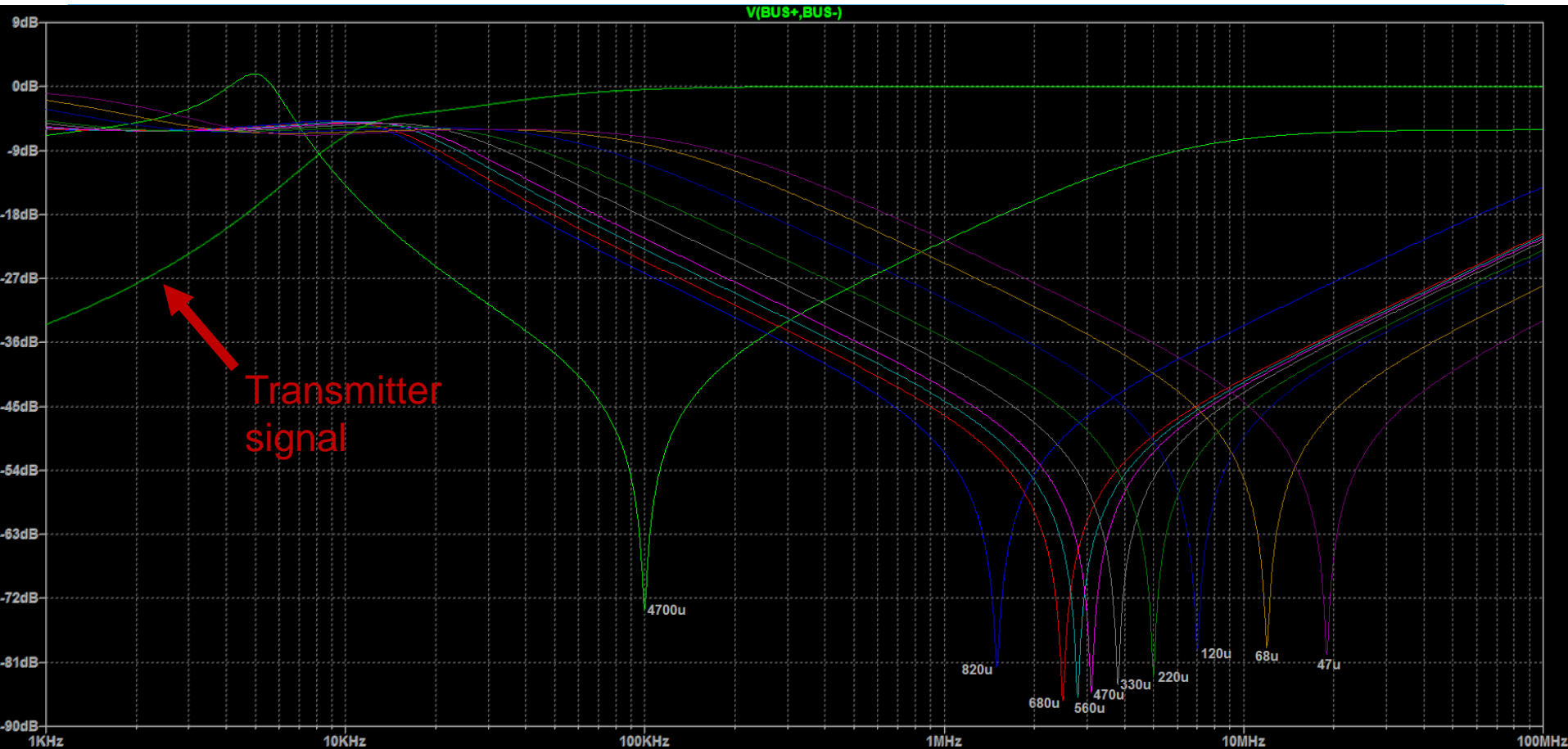

- Should we add a low-pass filter for high-frequency noise?

Capacitor value dependence (1)

- Capacitance added via EMC protection (TVS diodes act as capacitors when not conducting)
 - Inductors also have capacitance; this is included in inductor model
- Capacitive effects depend more on distances between components rather than distance from transmitter
- Even spacing of components = best case scenario

C = 1.5 pF (nominal)

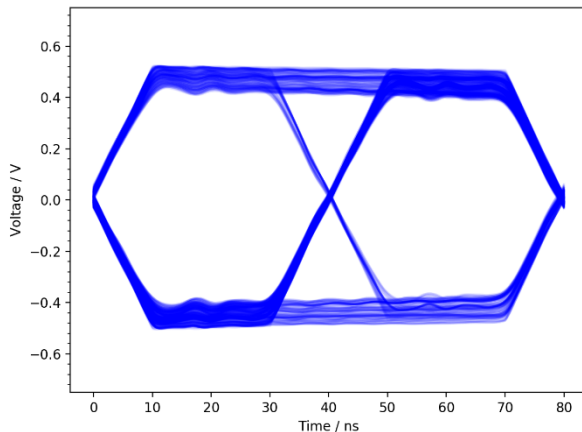

C = 10 pF

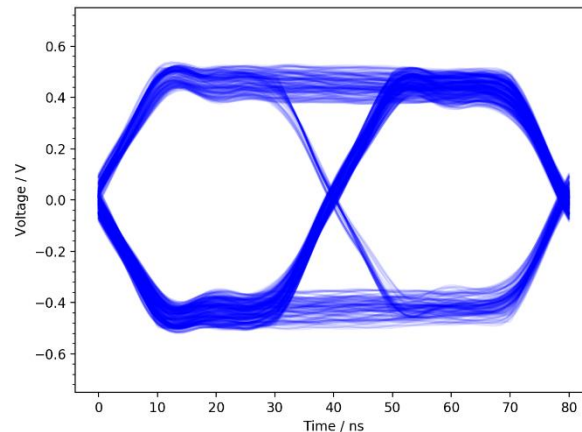

C = 30 pF

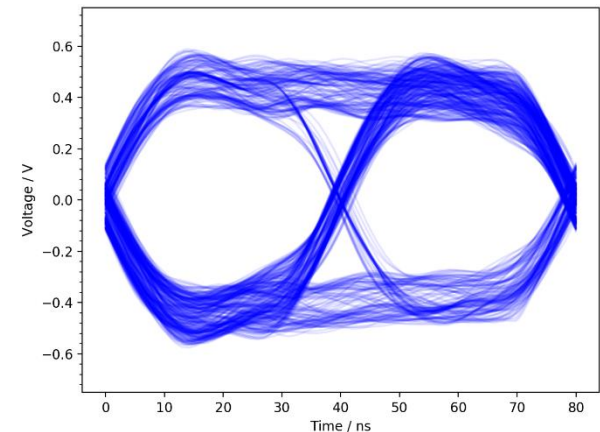

$R = 10 \text{ k}\Omega$
 $L = 940 \text{ }\mu\text{H}$
 $C = 10 \text{ pF}$

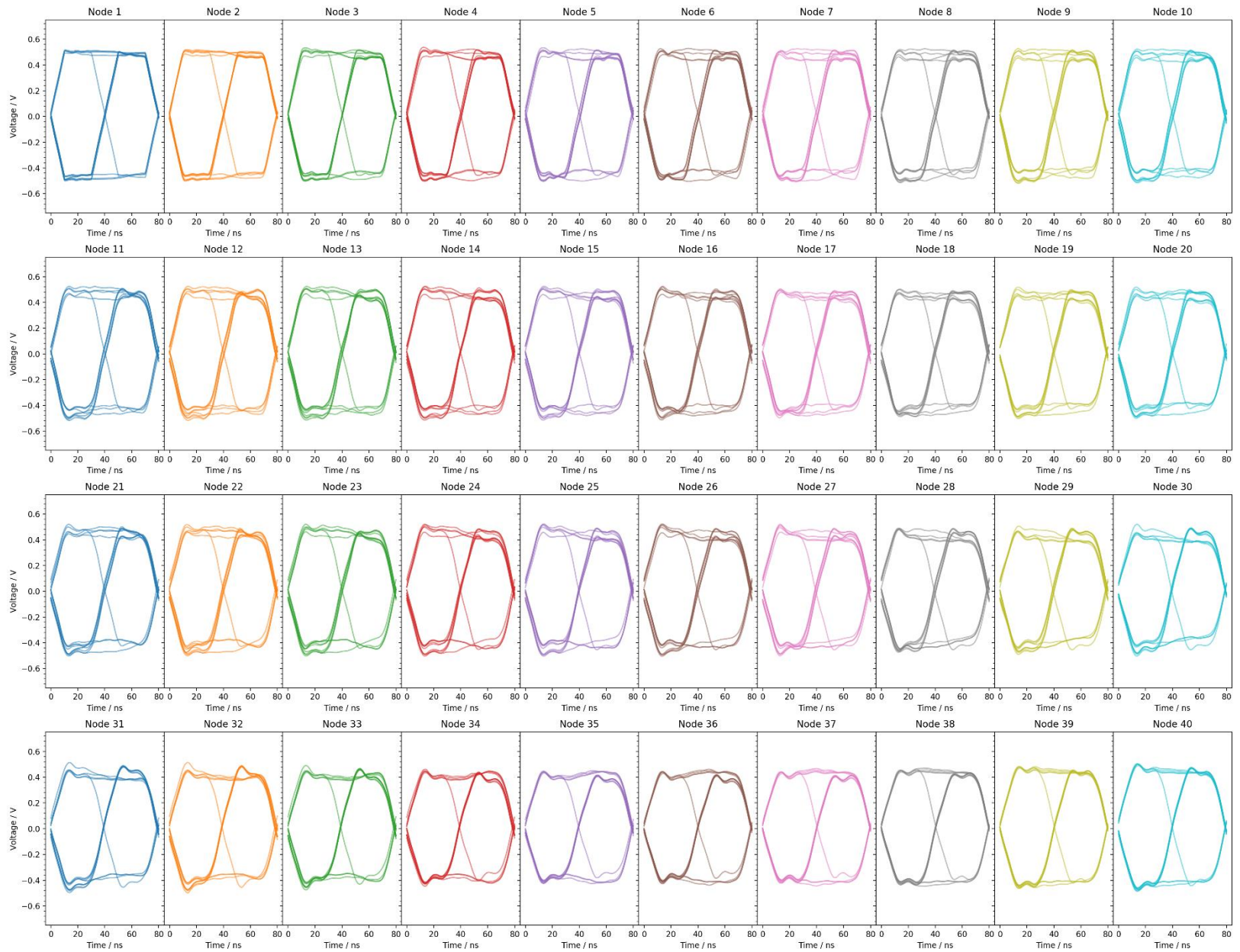

Capacitor value dependence (2)

- When all nodes are grouped together at the end of a 25 m long bus, increasing capacitance deteriorates performance rapidly
- TVS component capacitance should be minimized
- Stub and connector capacitance is not considered in this simulation run

C = 1.5 pF (nominal)

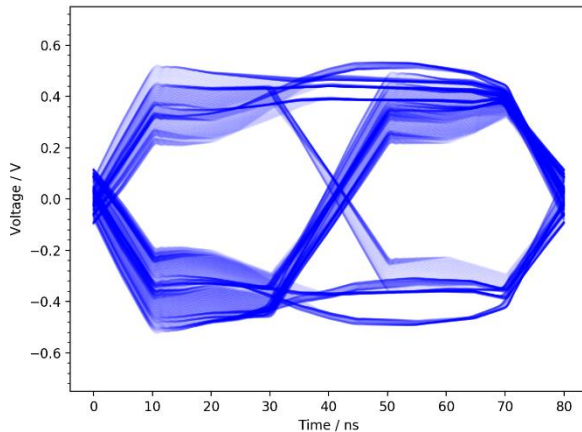

C = 4.5 pF

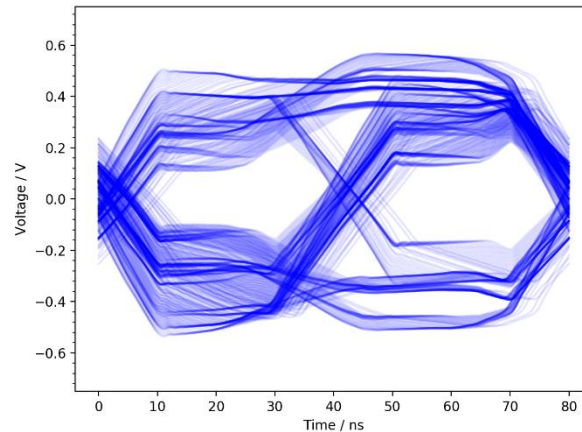

C = 10 pF

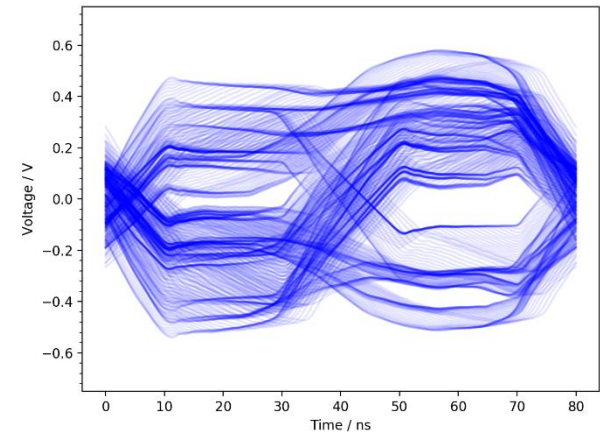

Stubs

- Stubs can be well approximated as a lumped element
- For a $100\ \Omega$ lossless transmission line:
 - 2 cm stub $\rightarrow L = 10\ \mu\text{H}$, $C = 1\ \text{pF}$
 - 10 cm stub $\rightarrow L = 50\ \mu\text{H}$, $C = 5\ \text{pF}$ (shown below)
- Lumped LC stub does not include time delay

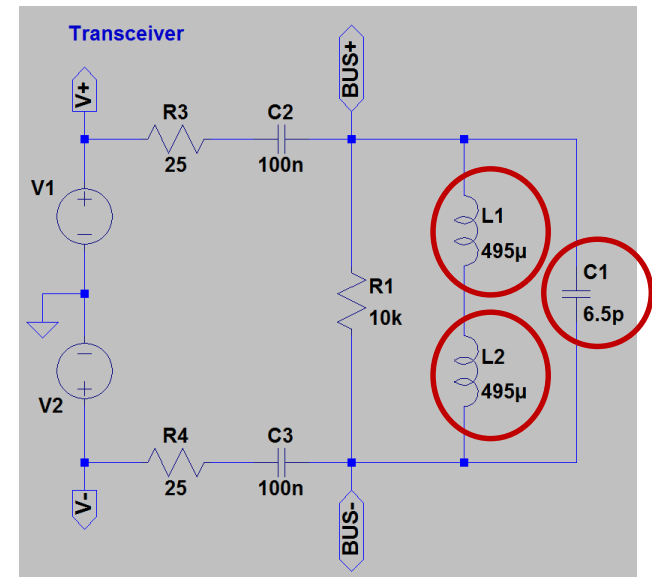
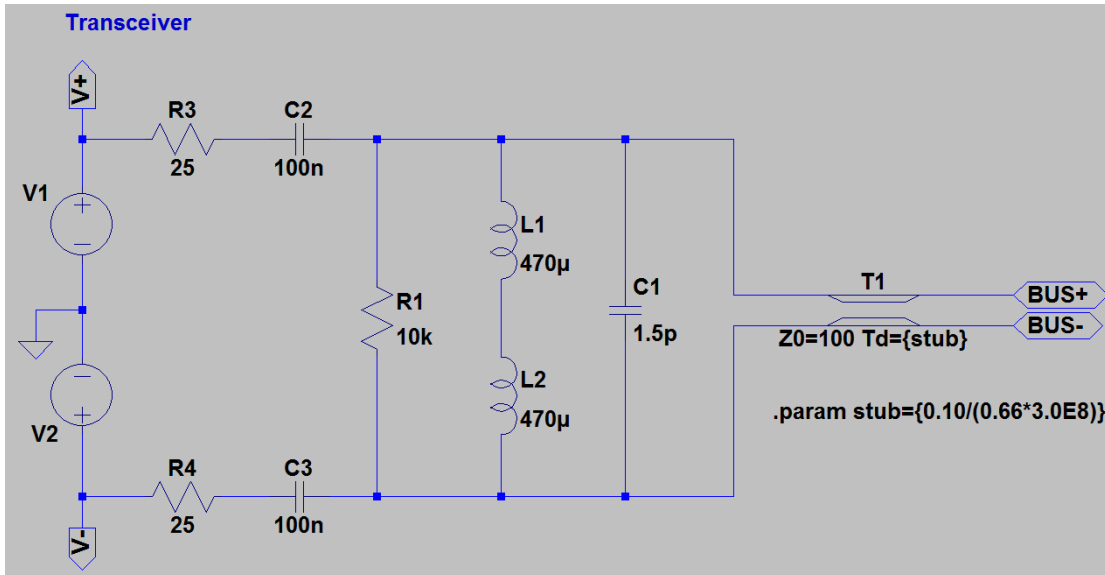

Stubs

Baseline (no stub)

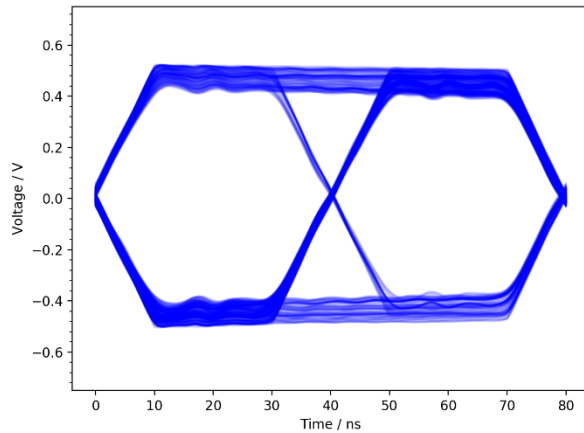

Transmission line stub, 2 cm

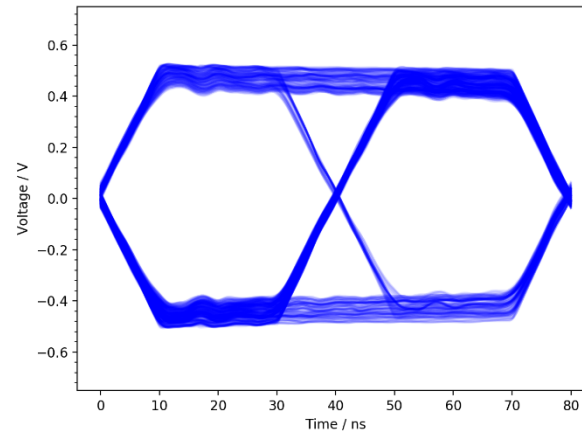

Lumped LC stub, 2 cm

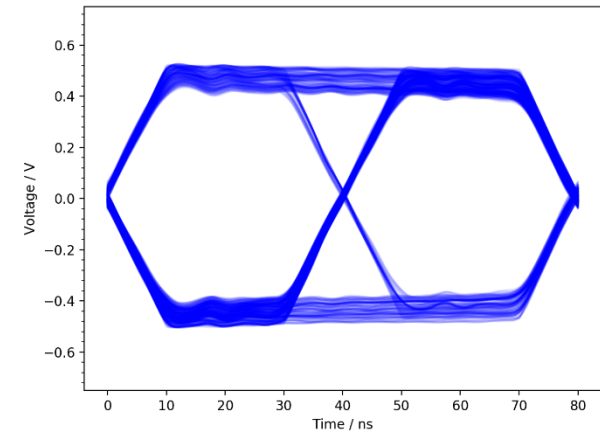

Transmission line stub, 10 cm

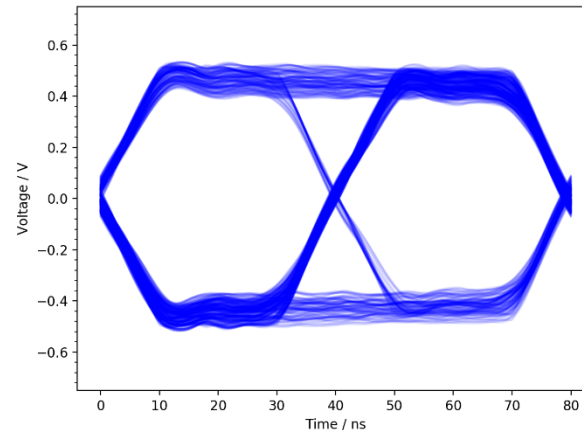

Lumped LC stub, 10 cm

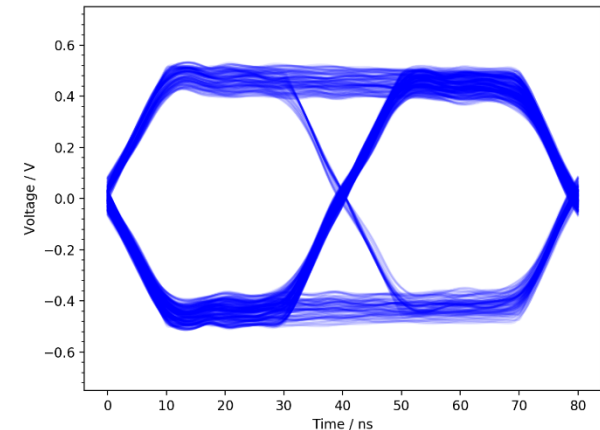

- Stubs can be well approximated by adding inductance and capacitance
- Earlier conclusions regarding L and C effects hold

Rise time effects

Even spacing, $R_t = 10$ ns

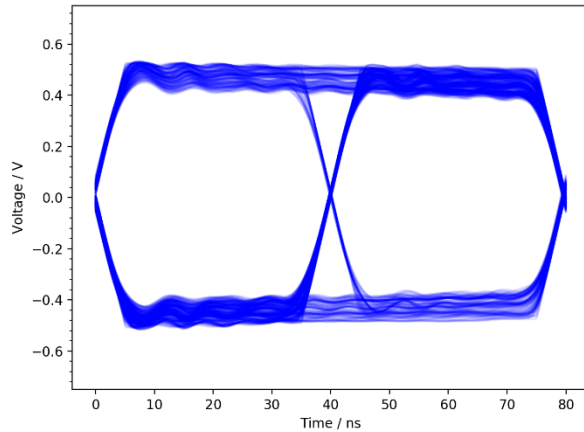

Even spacing, $R_t = 20$ ns

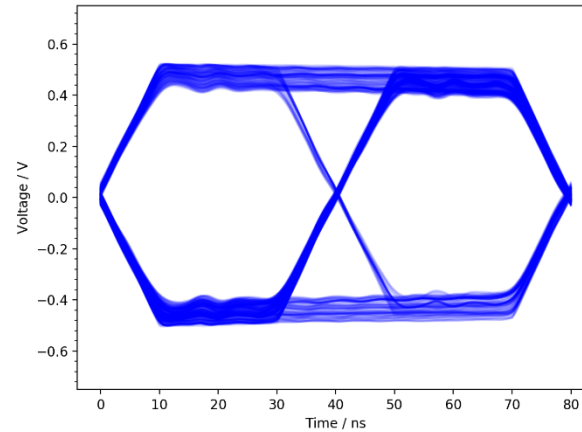

Even spacing, $R_t = 30$ ns

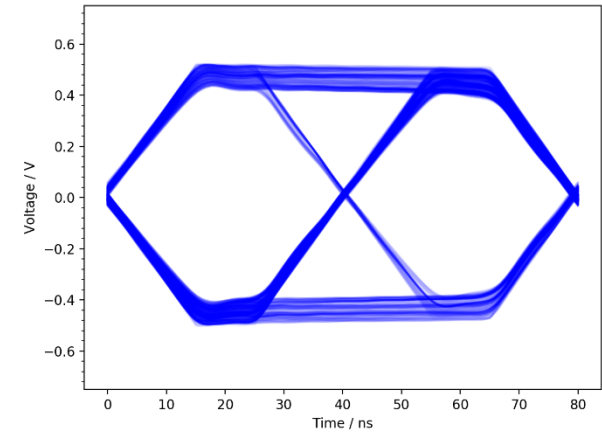

End clustered, $R_t = 10$ ns

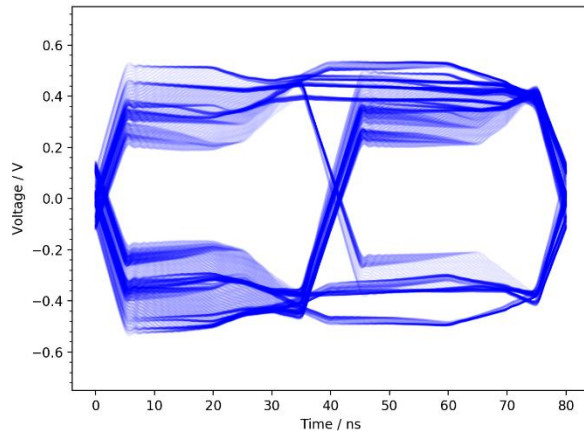

End clustered, $R_t = 20$ ns

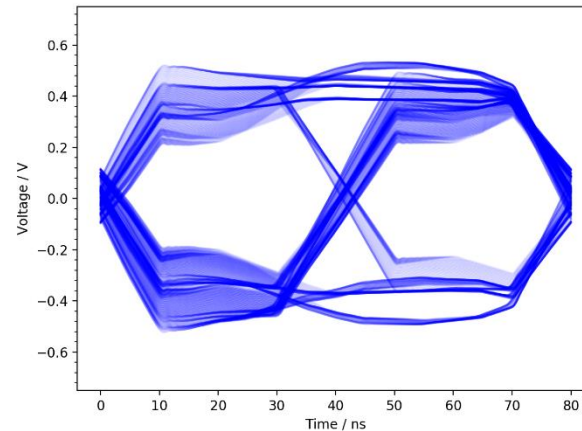

End clustered, $R_t = 30$ ns

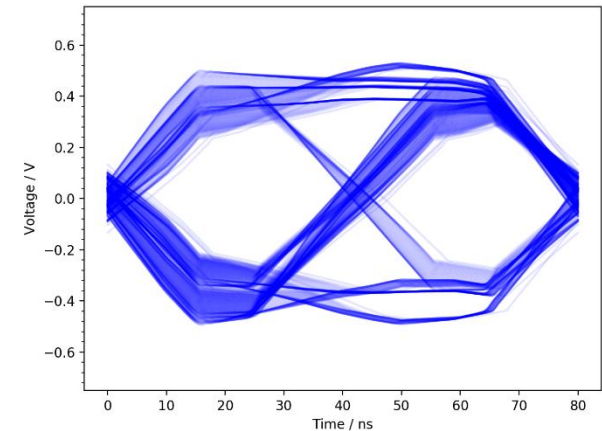

$$R = 10 \text{ k}\Omega, L = 940 \text{ }\mu\text{H}, C = 1.5 \text{ pF}$$

CONCLUSIONS AND FOLLOW-UP

Conclusions

- Clauses 8 and 10 provide general concepts for a multidrop system, but cannot be used directly in our case
- Our system can be modeled as an RLC system (similar to AS-i)
- Grouping nodes at end of bus may be worst-case, and should be used for determining component values
- Suggested component values:

R	L	C
> 5 k Ω	440 μ H – 1 mH (total)	< 4.5 pF

Follow-up work

- More node position configurations
- Real transmission line (validate usage of the ideal model)
- Injecting noise into the line
- Consider sensitivity to component tolerances and temperature

BACKUP SLIDES

Clause 8

- Standardizes Medium Attachment Unit (MAU) for 10BASE5
 - 10 Mb/s
 - 500 m of coaxial trunk
 - bus topology (mixing segment)
- A partial description follows

Clause 8: Cable and terminators

8.4.1 Coaxial cable electrical parameters

8.4.1.1 Characteristic impedance

The average characteristic cable impedance shall be $50 \pm 2 \Omega$ measured at 10 MHz according to IEC 60096-1: 1986 and Amd. 2: 1993. Periodic variations in impedance along a single piece of cable may be up to $\pm 3 \Omega$ sinusoidal centered around the average value, with a period of less than 2 m.

8.5.2.1 Termination

Coaxial cable terminators are used to provide a termination impedance for the cable equal in value to its characteristic impedance, thereby minimizing reflection from the ends of the cables. Terminators shall be packaged within an inline female receptacle connector. The termination impedance shall be $50 \Omega \pm 1\%$ measured from 0 MHz to 20 MHz, with the magnitude of the phase angle of the impedance not to exceed 5° . The terminator power rating shall be 1 W or greater.

Cable: $50 \Omega \pm 2 \Omega$, average
Termination: $50 \Omega \pm 1\%$, resistive

Clause 8: Stubs

8.5.3 MAU-to-coaxial cable connection

A means shall be provided to allow for attaching a MAU to the coaxial cable. The connection shall not disturb the transmission line characteristics of the cable significantly; it shall present a predictably low shunt capacitance, and therefore a negligibly short stub length. This is facilitated by the MAU being located as close to its cable connection as possible; the MAU and connector are normally considered to be one assembly. Long (greater than 30 mm) connections between the coaxial cable and the input of the MAU jeopardize this objective.

30 mm maximum stub recommendation

Clause 8: Input impedance

8.3.1.1 Input impedance

The shunt capacitance presented to the coaxial cable by the MAU circuitry (not including the means of attachment to the coaxial cable) is recommended to be no greater than 2 pF. The resistance to the coaxial cable shall be greater than 100 k Ω .

These conditions shall be met in the power-off and power-on, not transmitting states (over the frequencies BR/2 to BR).

8.5.3.1 Electrical requirements

Requirements for the coaxial tap connector are as follows:

- a) *Capacitance*: 2 pF nominal connector loading measured at 10 MHz.

NOTE—Total capacitance of tap and active circuitry connected directly shall be no greater than 4 pF. Specific implementations may allocate capacitance between tap and circuitry as deemed appropriate.

- b) *Contact resistance* (applies to center conductor and shield contacts): 50 m Ω maximum for both shield and center conductor over useful connector lifetime.

≤ 4 pF

≤ 50 m Ω (series)

> 100 k Ω (parallel)

Power-off and power-on, not transmitting

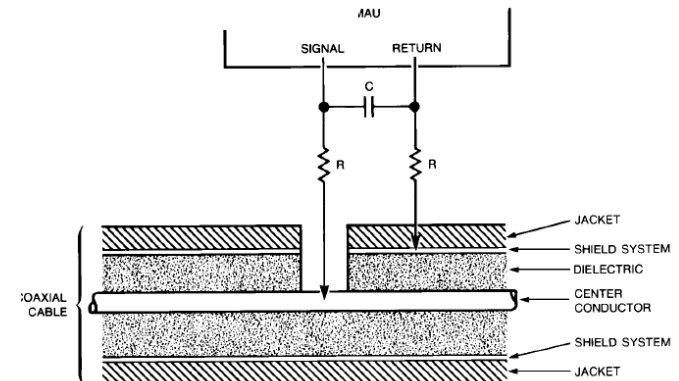

Clause 8: Maximum MAUs

8.6.1 Transmission system model

The maximum configuration for the physical transmission system is as follows:

- a) A trunk coaxial cable, terminated in its characteristic impedance at each end, constitutes a coaxial cable segment. A coaxial cable segment may contain a maximum of 500 m of coaxial cable and a maximum of 100 MAUs. The propagation velocity of the coaxial cable is assumed to be 0.77 c minimum ($c = 300\,000$ km/s). The maximum end-to-end propagation delay for a coaxial cable segment is 2165 ns.

100 MAUs
 $V_p = 0.77 c$

Clause 8: Cable section and placement rules

8.6.2.1 Cable sectioning

The 500 m maximum length coaxial cable segment need not be made from a single, homogeneous length of cable. The boundary between two cable sections (joined by coaxial connectors: two male plugs and a barrel) represents a signal reflection point due to the impedance discontinuity caused by the batch-to-batch impedance tolerance of the cable. Since the worst-case variation from $50\ \Omega$ is $2\ \Omega$, a possible worst-case reflection of 4% may result from the joining of two cable sections. The configuration of long cable segments (up to 500 m) from smaller sections must be made with care. The following *recommendations* apply, and are *given in order of preference*:

- a) If possible, the total segment should be made from one homogeneous (no breaks) cable. This is feasible for short segments, and results in minimal reflections from cable impedance discontinuities.
- b) If cable segments are built up from smaller sections, it is recommended that all sections come from the same manufacturer and lot. This is equivalent to using a single cable, since the cable discontinuities are due to extruder limitations, and not extruder-to-extruder tolerances. There are no restrictions in cable sectioning if this method is used. However, if a cable section in such a system is later replaced, it shall be replaced either with another cable from the same manufacturer and lot, or with one of the standard lengths described below.

Clause 8: Cable section and placement rules

- c) If uncontrolled cable sections must be used in building up a longer segment, the lengths should be chosen so that reflections, when they occur, do not have a high probability of adding in phase. This can be accomplished by using lengths that are odd integral multiples of a half wavelength in the cable at 5 MHz; this corresponds to using lengths of 23.4 m, 70.2 m, and 117 m (± 0.5 m) for all sections. These are considered to be the standard lengths for all cable sections. Using these lengths exclusively, any mix or match of cable sections may be used to build up a 500 m segment without incurring excessive reflections.

NOTE—If cable segments are to be added to existing installations, then care shall be taken (explicit physical or TDR measurements) to ensure that no more than a 500 m cable segment results.

- d) As a last resort, an arbitrary configuration of cable sections may be employed, if it has been confirmed by analysis or measurement that the worst-case signal reflection due to the impedance discontinuities at any point on the cable does not exceed 7% of the incident wave when driven by a MAU meeting these specifications.

- Lengths are odd multiples of half wavelength
- Reflections less than 7% of incident wave

Clause 10

- Standardizes Medium Attachment Unit (MAU) for 10BASE2
 - 10 Mb/s
 - 185 m of coaxial trunk
 - bus topology (mixing segment)
- A partial description follows

Clause 10: Cable and terminators

10.5.1 Coaxial cable electrical parameters

The parameters specified in 10.5.1 are met by cable types RG 58 A/U or RG 58 C/U.

10.5.1.1 Characteristic impedance

The average characteristic cable impedance shall be $50 \pm 2 \Omega$. Periodic variations in impedance along a single piece of cable may be up to $\pm 3 \Omega$ sinusoidal, centered around the average value, with a period of less than 2 m.

10.6.2 Coaxial cable terminator

Coaxial cable terminators are used to provide a termination impedance for the cable equal in value to its characteristic impedance, thereby minimizing reflection from the ends of the cables. Terminators shall be packaged within a male or female connector. The termination impedance shall be $50 \Omega \pm 1\%$ measured from 0 MHz to 20 MHz, with the magnitude of the phase angle of the impedance not to exceed 5° . The terminator power rating shall be 0.5 W or greater. A means of insulation shall be provided with each terminator.

Cable: $50 \Omega \pm 2 \Omega$, average
Termination: $50 \Omega \pm 1\%$, resistive

Clause 10: Stubs

10.6.3 MAU-to-coaxial cable connection

A BNC “T” (plug, receptacle, plug) adaptor provides a means of attaching a MAU to the coaxial cable. The connection shall not disturb the transmission line characteristics of the cable significantly; it shall present a low shunt capacitance, and therefore a negligibly short stub length. This is facilitated by the MAU being located as close to its cable connection as possible; the MAU and connector are normally considered to be one assembly. Long (greater than 4 cm) connections between the coaxial cable and the input of the MAU jeopardize this objective.

4 cm maximum stub recommendation

Clause 10: Input impedance

10.4.1.1 Input impedance

The shunt capacitance presented to the coaxial cable by the MAU circuitry (not including the means of attachment to the coaxial cable) is recommended to be not greater than 6 pF. The magnitude of the reflection from a MAU plus the cable connection specified in 10.6.3 shall not be more than that produced by an 8 pF capacitance when measured by both a 25 ns rise time and 25 ns fall time waveform. The resistance presented to the coaxial cable shall be greater than 100 k Ω .

These conditions shall be met in both the power-off and power-on, not-transmitting states.

≤ 8 pF

$\leq ??$ m Ω (series)

> 100 k Ω (parallel)

Power-off and power-on, not transmitting

Clause 10: Maximum MAUs

10.7.1 Transmission system model

The maximum configuration for the physical transmission system is as follows:

- a) A trunk coaxial cable, terminated in its characteristic impedance at each end, constitutes a coaxial cable segment. A coaxial cable segment may contain a maximum of 185 m of coaxial cable and a maximum of 30 MAUs. The propagation velocity of the coaxial cable is assumed to be 0.65 c minimum ($c = 3 \times 10^8$ m/s). The maximum end-to-end propagation delay for a coaxial cable segment is 950 ns.

30 MAUs

$V_p = 0.65 c$

Clause 10: Cable section and placement rules

10.7.2.1 Cable sectioning

The 185 m maximum length coaxial cable segment will be made from a number of cable sections. As the variation on cable characteristic impedance is $\pm 2 \Omega$ on 50Ω , a possible worst-case reflection of 4% may result from the mismatch between two adjacent cable sections. The MAU will add to this reflection by the introduction of its noninfinite bridging impedance.

The accumulation of this reflection can be minimized by observing a minimum distance between MAUs (and between cable sections). In order to maintain reflections at an acceptable level, the minimum length cable section shall be 0.5 m.

10.7.2.2 MAU placement

MAU components and their associated connections to the cable cause signal reflections due to their noninfinite bridging impedance. While this impedance must be implemented as specified in 10.6, the placement of MAUs along the coaxial cable must also be controlled to ensure that reflections from the MAU do not accumulate to a significant degree.

Coaxial cable sections as specified in 10.7.2.1 shall be used to connect MAUs. This guarantees a minimum spacing between MAUs of 0.5 m.

- 0.5 m minimum cable section
- 0.5 m minimum MAU spacing