

Power Compatibility for 10SPE

Chad Jones, Cisco

Lennart Yseboodt, Philips Lighting

Let's Learn from History

- Twisted-Pair Ethernet pre-existed PoE
- Billions of TP devices already deployed at the start of 802.3af
- Some would be damaged by application of voltage
- Required complex detection scheme
- Bus powering makes detection even more complex

How to Solve

- Require all 10SPE PHYs to tolerate the highest possible operating voltage for any of the powering schemes
- This is accomplished via two small caps
- This applies to long and short reach PHYs (**ALL**)
- This adds no or no significant cost

DC Isolation

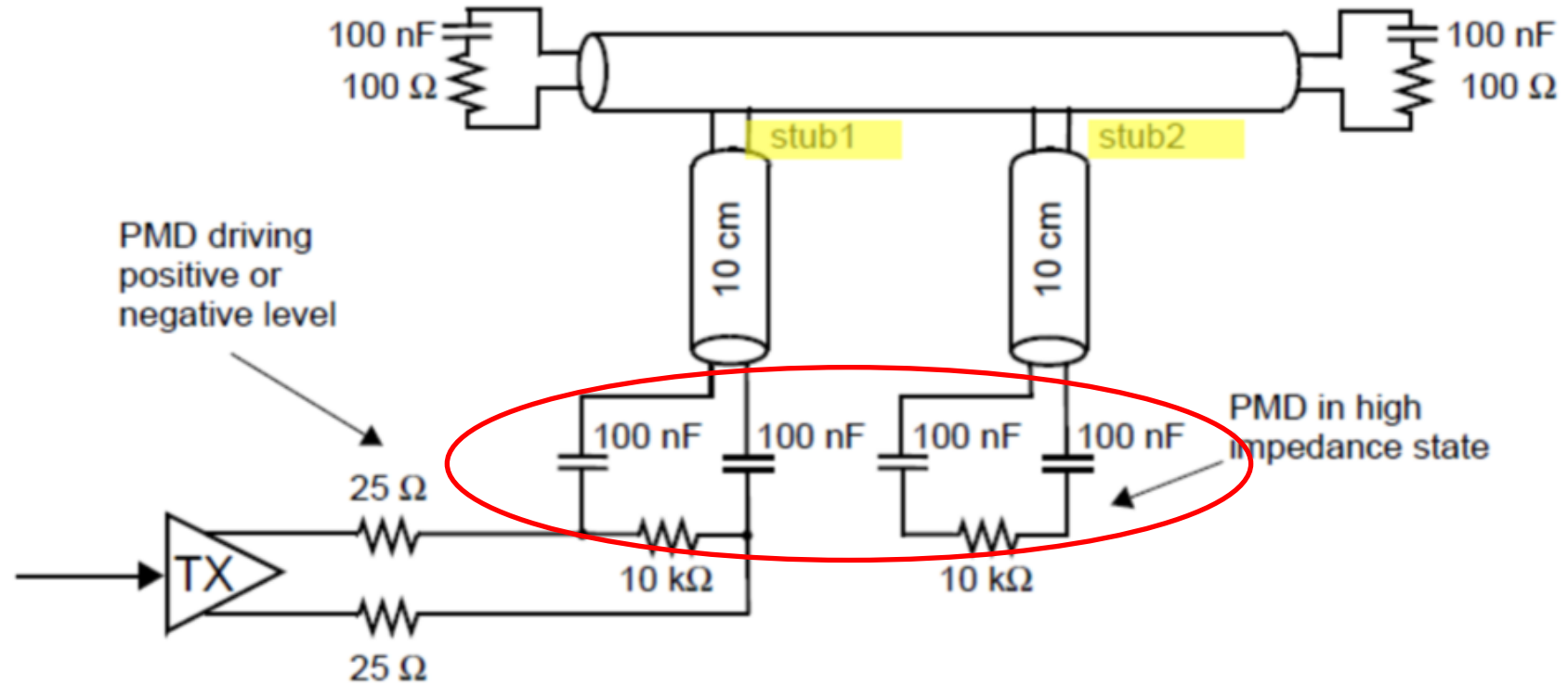

Source: beruto_3cg_03_0318.pdf

Compatibility with power for 10SPE v101

146.8.4 MDI fault tolerance

~~For industrial applications †~~ The wire pair of the MDI shall, under all operating conditions, withstand without damage the application of short circuits of any wire to the other wire of the same pair or ground potential or positive voltages of up to 60 V dc with the source current limited to 1200 mA, as per Table 146–8, for an indefinite period of time. Normal operation shall resume after the short circuit(s) is/are removed.

~~For automotive applications the wire pair of the MDI shall, under all operating conditions, withstand without damage the application of short circuits of any wire to the other wire of the same pair or ground potential or positive voltages of up to 50 V dc with the source current limited to 150 mA, as per Table 146–8, for an indefinite period of time. Normal operation shall resume after the short circuit(s) is/are removed.~~

The wire pair of the MDI shall also withstand without damage high-voltage transient noises and ESD per application requirements. The following table gives an overview about possible connection faults for the wire pair (BI_DA+ and BI_DA-):

Replace in Table 146–8 “50V/60V dc” by “60V dc”

Make new subclause 147.6a as follows:

147.6a MDI specification

147.6a.1 MDI fault tolerance

The wire pair of the MDI shall, under all operating conditions, withstand without damage the application of short circuits of any wire to the other wire of the same pair or ground potential or positive voltages of up to 60 V dc with the source current limited to 1200 mA, as per Table 147–3, for an indefinite period of time. Normal operation shall resume after the short circuit(s) is/are removed.

Copy Table 146–8 to here, as Table 147–3.

Motion

Move that the IEEE P802.3cg Task Force accept slide 5 of jones-yseboodt_3cg_01a_0318.pdf as an additional resolution to comment 77

Move: Lennart Yseboodt

Second: Chad Jones

Technical

Y: xx N: xx A: xx