

802.3cg Use Cases and PHY Options

IEEE 802.3 NEA Ad Hoc

George Zimmerman

CME Consulting

15 June 2017

Overview

- IEEE P802.3cg currently has 2 PHY objectives:
 - Define the performance characteristics of a link segment and a PHY to support operation over this link segment with single twisted pair supporting up to four inline connectors using balanced cabling for up to at least 15 m reach
 - Define the performance characteristics of a link segment and a PHY to support point-to-point operation over this link segment with single twisted pair supporting up to 10 inline connectors using balanced cabling for up to at least 1 km reach
- Use cases for these are simple:
 - 15m, 4 connector, point-to-point link segment (w/EMC margin)
 - Envisioned for automotive & industrial pods
 - 1km, 10 connector, point-to-point link segment
 - Adopted link segment requirements based on process control requirements
 - Gauge to vary with powering requirements, PHY can run at all shorter distances
- **BUT, THIS IS NOT ALL.....**

Varied use cases already in .3cg

- In-cabinet, chassis
 - Short (0.1m? to 15m)
 - Narrow wire (28 AWG?), 0-4 connectors
 - Multipoint?
- Cars
 - 4 conn, 15m
 - Multipoint topologies?
- Industrial pods
 - Pods 5-40m, 0-4 connectors
 - Wiring gauge?
- Trunks
 - Trunks to 1km, 10 conn
 - Thicker wire (14,18 AWG)
- Spurs / In bldg. distribution
 - To 200m (in bldg. ~100m), to 4 connectors
 - Gauge likely based on power, 16-18AWG, but also could be smaller

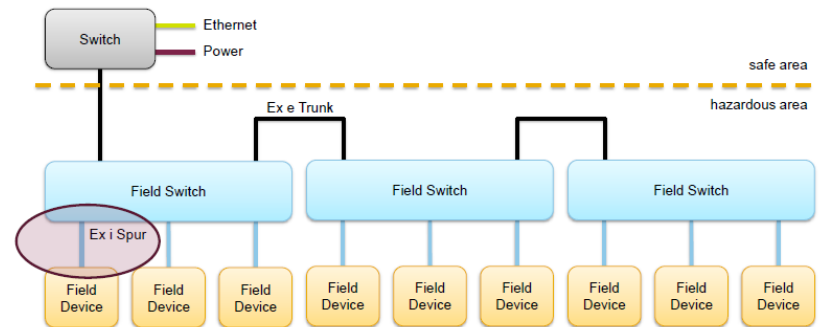

Additional Use Cases Discussed

- Herbst_3cg_01a_0517:
 - Building infrastructure, signaling, sensing
 - Most < 1 Mbps, reach varies with infrastructure
 - 10Mbps would give lots of room for growth
- Lewis_3cg_01_0317:
 - Intra-system, short reach, management
 - Rate TBD, faster than MDIO? (> 2.5 Mbps)
 - Maybe this meets need in perezaranda_NGAUTOah_190417.pdf without redefining MDIO?

Reach is determined by several things

- Reach is fundamentally determined only by one factor: propagation delay
 - All other metrics can be changed with wire gauge, temperature or noise margin reserved for environmental effects
 - Link prop. delay impacts echo canceller length or allowed delay for time division duplexing (FDD systems may be immune)
- Non-industrial or low-power short-reach may be small gauge
 - This make a short PHY look like a long one of larger gauge in terms of Equalization and AFE
- **PAY ATTENTION TO INSERTION LOSS AT MIDBAND AND NYQUIST!**

Existing Technologies & channels

Technology	Bits / Sec / Hz /pair	Mid-Band Freq.	Insertion Loss at Mid Band	Band-edge Freq.	Insertion Loss at Band-edge	Primary Impairments
100BASE-TX (dual-simplex)	2	31.25 MHz	12.6 dB	62.5 MHz	18.5 dB	Near-End Crosstalk & Intersymbol Interference
1000BASE-T (echo-cancelled)	4.1	31.25 MHz	12.6 dB	62.5 MHz	18.5 dB	Far-End & (residual) Near-End Crosstalk
10GBASE-T (echo-cancelled)	6.35	200 MHz	31.7 dB	400 MHz	46.9 dB	Alien Crosstalk & Receiver Noise/Residual Echo
40GBASE-CR4 (simplex)	2	2.571825 GHz	12.7 dB*	5.15625 GHz	20.9 dB	Timing Jitter, Near & Far-End Crosstalk

* Loss is for cable assembly – Including PCB channel loss, mid band IL is up to 16.5dB

Intermediate reach doesn't look long or short reach

- 1000m PHY needs to tolerate ~26 dB loss at Nyquist
- 200m or less is in an entirely different PHY class, even if 28AWG is used
- Connector effects are probably a bigger issue than reach
- Need connector information

AWG	Length @ IL limit(m)	Length @ ohms loop R			4M IL @15m	IL @ 100m	IL @ 200m	IL @ 1km
		6.5	12	25	4 conn	4 conn	4 conn	10 conn
14	1589	353	652	1359	0.4	1.5	3.4	16.5
16	1261	221	408	850	0.5	1.8	4.2	20.7
18	1000	139	258	536	0.5	2.3	5.3	25.9
20	793	88	162	337	0.6	2.8	6.6	32.6
22	629	55	102	212	0.8	3.5	8.3	41.0
24	499	35	64	133	0.9	4.4	10.4	51.6
26	395	22	40	84	1.1	5.5	13.1	65.0
28	314	14	25	53	1.4	6.9	16.5	81.9

<100m at 10Mbps = low loss

- At 15m, even small gauge = low loss
 - Unlikely to need complex AFE/Equalization
 - Even at 200m, 24 AWG, < 10dB IL
 - Connectors will determine complexity
 - Sparse EQ/EC architectures minimize complexity
- Extra margin at 15m can be used for EMC environment

AWG	Length @ IL limit	4MHz IL	4 conn length at	4MHz IL	4 conn length	4 conn length at	
		@15m strnd	15m 28AWG strnd IL	@ 100m solid	at 100m 24AWG solid IL	IL @ 200m solid	200m 22AWG solid IL
14	1589	0.4	76	1.5	319	2.8	506
16	1261	0.5	60	1.8	253	3.5	401
18	1000	0.5	48	2.3	201	4.4	318
20	793	0.6	38	2.8	159	5.5	252
22	629	0.8	30	3.5	126	6.9	200
24	499	0.9	24	4.4	100	8.7	159
26	395	1.1	19	5.5	79	10.9	126
28	314	1.4	15	6.9	63	13.7	100

2 PHY Options

- There are several options, these are 2
 1. Fewest PHYs, highest complexity:
 - Use the 802.3cg 1000m PHY for all links
 - Use this as relative cost baseline
 - Big question – how much is it test/package limited – Need silicon vendor/operations-oriented analysis
 2. Lowest complexity, best optimization:
 - Long reach PHY for industrial channels
 - Optimize low-loss PHY for high-volume MICE1 intermediate reach & automotive pt-to-pt in automotive EMI
 - Fix maximum link length, pick something > 200m
 - Model channel & connectors – consider sparse EQ/EC
 - Compare relative cost to long reach

Other simplifications

- Consider common PCS, even if modulation (PMA) is different
 - E.g., similar to 100GBASE-KP4
 - PAM-3 PMA/PMD for long reach
 - Other PMA/PMD for short reaches
- Consider short reach mandatory, long reach as optional capability
 - Target serving all < 200m links with short reach

What does this buy us?

- Ultra low complexity for most links
 - IF 10Mbps is right rate, should cover many applications
- Interoperability of all PHYs at intermediate reaches, without complexity burden
 - Optional PMA/PMD type for extended reach
 - Better than 2 distinct PHY types

Next steps to proceed

- Connector models (inline) and stub models for various use case channels
- Validate low-complexity PHY assumptions
- Examine straw-man schemes

Thank You!