

CORNING

400G-SR8 MDI Definition and Lane Assignments

Steve Swanson
828-901-5328
May 21, 2018

Switch to Server Breakout

- 400G-SR8 module application will be primarily for breakout applications

Switch to Server Breakout

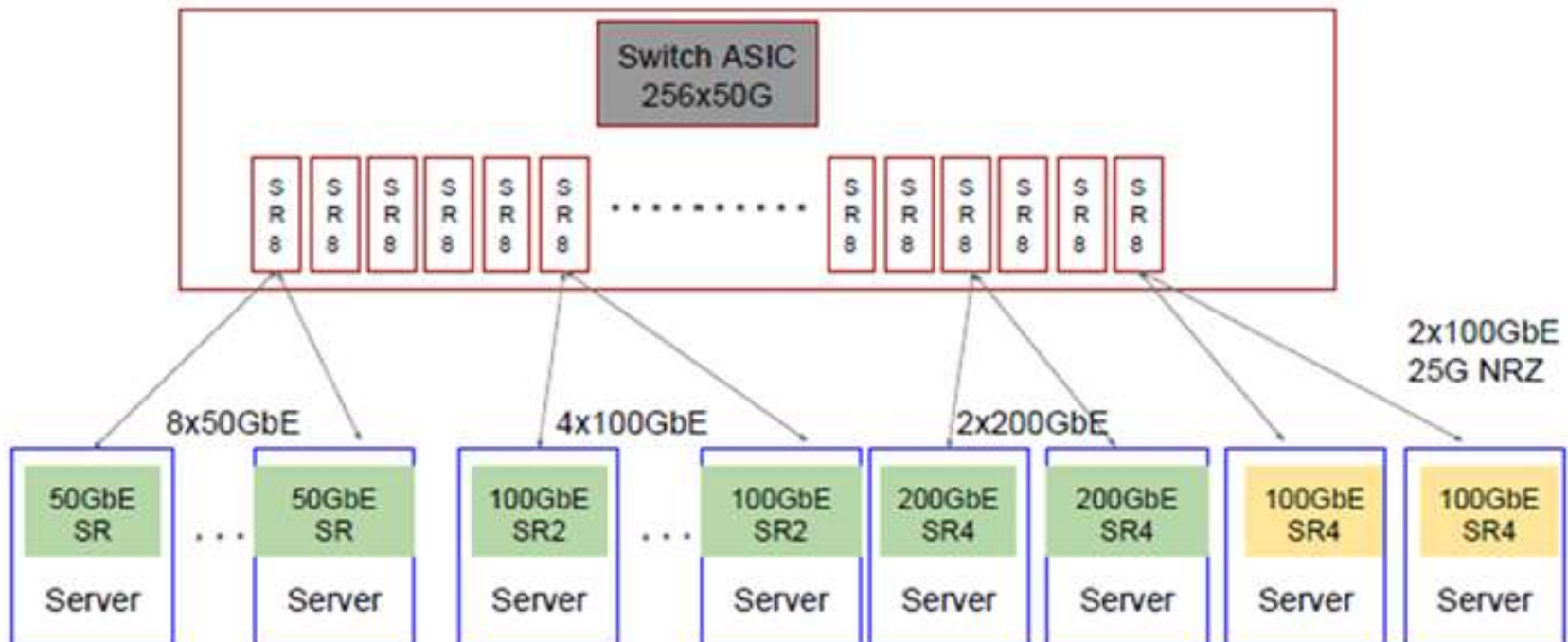

MPO Connector Formats

- 12f (available in 1-row and 2-row)
- 16f (available in 1-row and 2-row)
 - Same size with
 - Offset key
 - Smaller pins with wider pitch

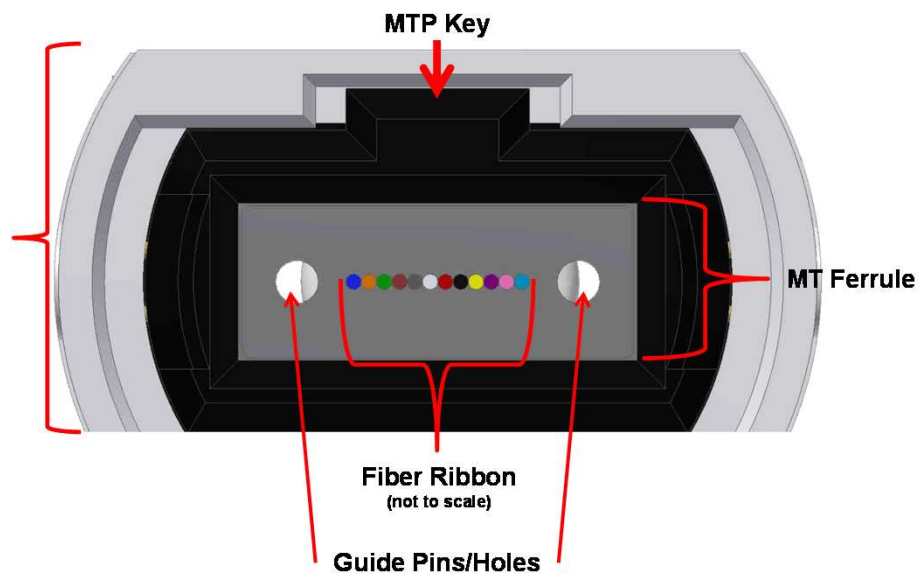

Source: USCONEC

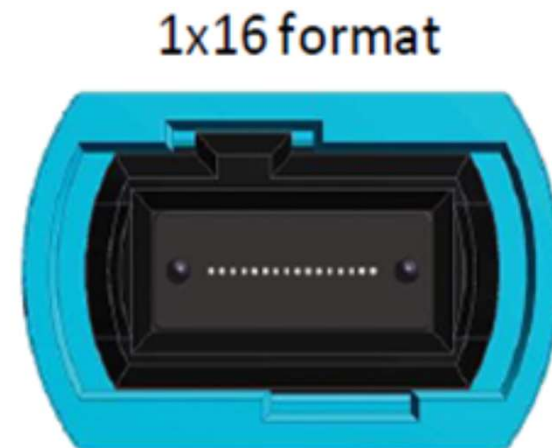

Source: USConec

Current IEEE Standardized Lane Assignments

- 40GBASE-SR4

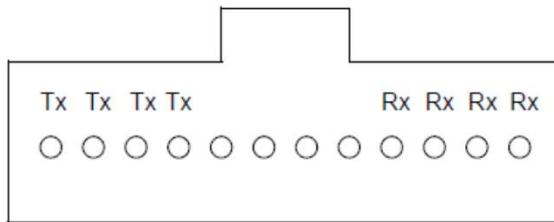
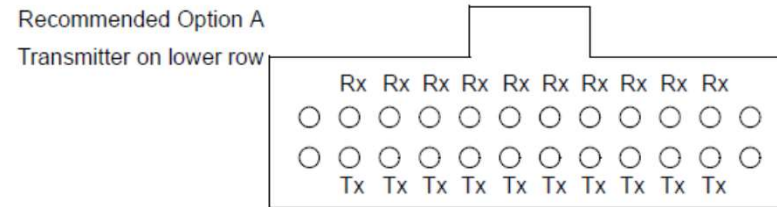
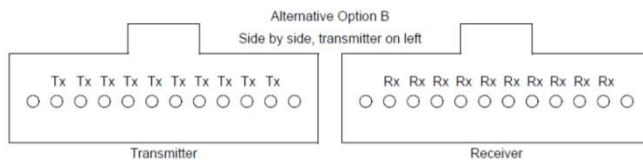

Figure 86-6—40GBASE-SR4 optical lane assignments

- 100GBASE-SR10



- 100GBASE-SR10



- 100GBASE-SR10

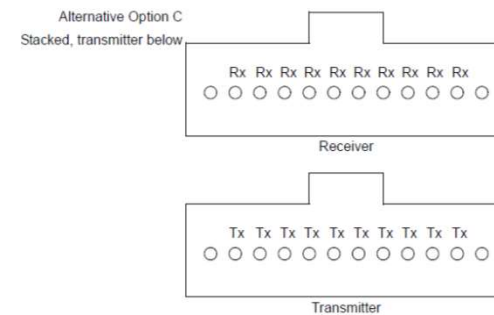

Figure 86-7—100GBASE-SR10 optical lane assignments

Current IEEE Standardized Lane Assignments

- 100GBASE-SR4

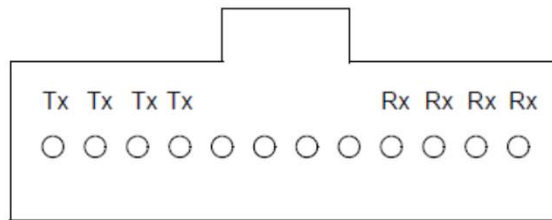

Figure 95-7—100GBASE-SR4 optical lane assignments

- 400GBASE-SR16

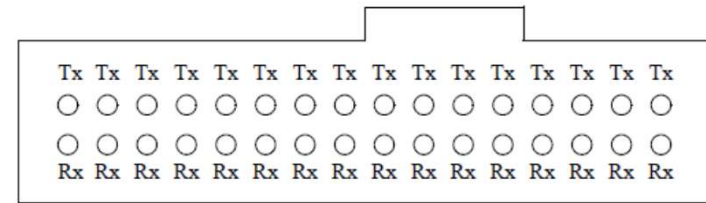

Figure 123-4—400GBASE-SR16 optical lane assignments

- 100GBASE-SR2

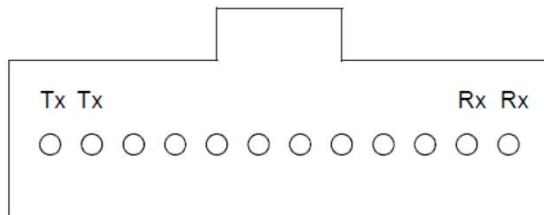

Figure 138-6—Optical lane assignments for 100GBASE-SR2

- 200GBASE-SR4

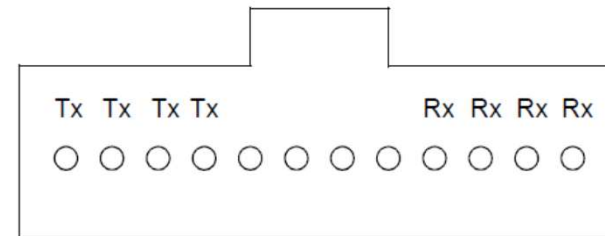
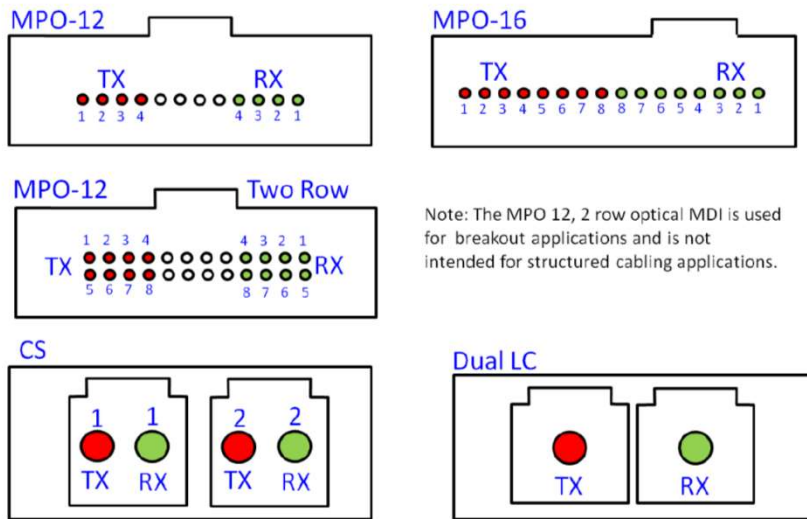

Figure 138-7—Optical lane assignments for 200GBASE-SR4

Current MSA Lane Assignments

- QSFP-DD MSA

- OSFP MSA



Note: The MPO 12, 2 row optical MDI is used for breakout applications and is not intended for structured cabling applications.

Figure 33: Optical Media Dependent Interface port assignments

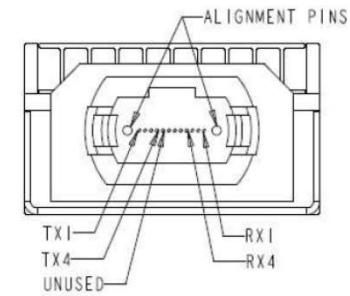

Channels (x: unused position) Tx1 Tx2 Tx3 Tx4 x x x x Rx4 Rx3 Rx2 Rx1
 Figure 52. Optical receptacle and channel orientation for MPO 12 connector

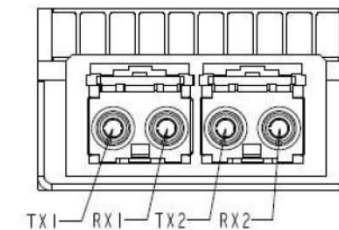

Figure 53. Optical receptacle and channel orientation for dual CS connector

Pros and Cons of Dual-Row 12f MPO vs. Single-Row 16f MPO

- Dual-Row 12f
 - Dual-Row performance has typically been more difficult to achieve but process now yielding same performance as Single-Row
- 12f has become “workhorse” due to popularity of IEEE SR4 variants
 - Prevalent in most manufacturing ecosystems
 - Specified in IEEE for 40G-SR4, 100G-SR4, 100-SR2 and 200G-SR4
 - Specified in both QSFP-DD and OSFP
 - Both 12f and 24f standardized by IEC and TIA
- Dual-row connectivity can add some complexity in that dual-row array polarity transposes signals horizontally and vertically
 - Lane assignments must be chosen for compatibility but this is exactly what the QSFP-DD MSA does
- Single-Row 16f
 - Single-Row has demonstrated lower loss in past
 - Single-Row is easier to terminate
 - Single-Row potentially lower cost
- 16f originally developed as a Dual-Row MPO
 - Specified in 400G-SR16
 - 16f Specified in QSFP-DD but not OSFP
 - Both 16f and 32f standardized by IEC and TIA
- 16f adds manufacturing complexity
 - Offset keys
 - Additional SKUs

Structured Cabling

- None of the lane assignment options are problematic in relation to structured cabling
 - TIA-568.3-D notes “This Standard does not specify any polarity method that must be used for compliance to this Standard. Designers and installers are encouraged to contact their connectivity manufacturers to evaluate polarity options
- Annex C also notes the following with respect to array polarity
 - All array connectivity methods have the same goal: to create an optical path from the transmit port of one device to the receive port of another device
 - Different methods to accomplish this goal may be implemented; however these different methods may not be interoperable
 - It is recommended that a method be selected in advance and maintained consistently throughout an installation
 - While many methods are available to establish polarity, this Standard outlines sample methods that may be employed for array cabling systems. For convenience, these sample methods are referred to as Methods A, B, and C. No preference or priority is implied by this notation
- Structured cabling does not define a specific connectors
- There is a note in the QSFP-DD MSA, “The MPO 12f Two-Row optical MDI is used for breakout applications and is not intended for structured cabling solutions” – it is not clear why this note is included

Implementation Recommendation A for Clause 138

- Utilize similar text for the MDI lane assignment that is currently in Clause 138

138.10.3.x Optical lane assignments for 400GBASE-SR8

The eight transmit and eight receive optical lanes of 400GBASE-SR8 shall occupy the positions depicted in Figure 138-x when looking into the MDI receptacle with the connector keyway feature on top. The interface contains sixteen active lanes within 24 total positions. The four center positions in each row are unused. The transmit optical lanes occupy the leftmost four positions in each row. The receive optical lanes occupy the rightmost four positions in each row.

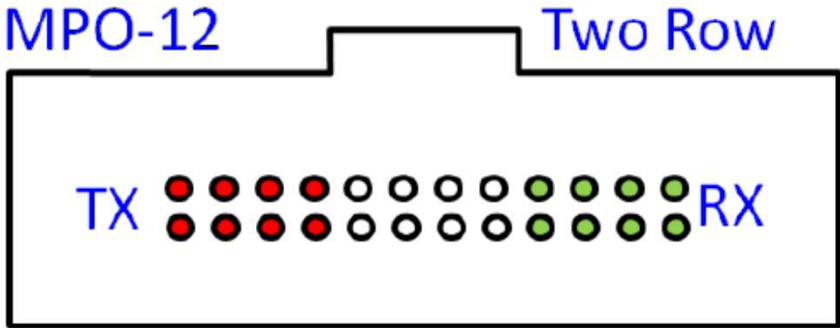

Figure 138-x-400GBASE-SR8 optical lane assignments

Implementation Recommendation B for Clause 138

- Utilize similar text for the MDI lane assignment that is currently in Clause 138

138.10.3.x Optical lane assignments for 400GBASE-SR8

The eight transmit and eight receive optical lanes of 400GBASE-SR8 shall occupy the positions depicted in Figure 138-x when looking into the MDI receptacle with the connector keyway feature on top. The interface contains sixteen active lanes. The transmit optical lanes occupy the leftmost eight positions. The receive optical lanes occupy the rightmost eight positions in each row.

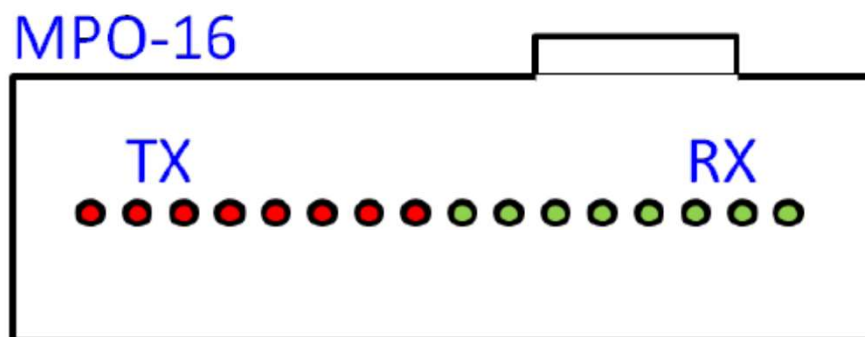

Figure 138-x-400GBASE-SR8 optical lane assignments

Recommendation for breakout

- To date, IEEE has not addressed breakout
 - It has been left to the MSAs
 - There may be no reason to address it now
- For 400G-SR8 it is recommended that the lane assignments outlined in QSFP-DD be used
 - My preference for SR8 is the Two-Row MPO-12 but could support the MPO-16 as well. No lane assignment changes are needed
 - Add a note pointing to Figure 33 of the QSFP-DD MSA or add an informative annex to Clause 138 with the lane assignments

