

Super-PON PCS Proposal

IEEE P802.3cs – August 22, 2019

Claudio DeSanti (Google)

Agenda

- Super-PON PCS Options Review
- Super-PON with 10G-EPON PCS
- Super-PON with 25G-EPON PCS

Super-PON Additional PCS Requirements

- Support tunable transmitters
- Support the 2.5G upstream speed
 - 1/4 of the 10G-EPON clock, or
 - 1/10 of the 25G-EPON clock

Summary from Last Meeting

- Two PCS options are possible
 - Leverage the 10G-EPON PCS
 - Leverage the 25G-EPON PCS
- In discovery, no need to convey the FSR Set information
 - An ONU operating on an FSR Set different from the one used by the OLT will simply not receive signals
- For 25G-EPON discovery, use only the DiscoveryInfo field
 - Don't use the ChannelMap field

Two PCS Options?

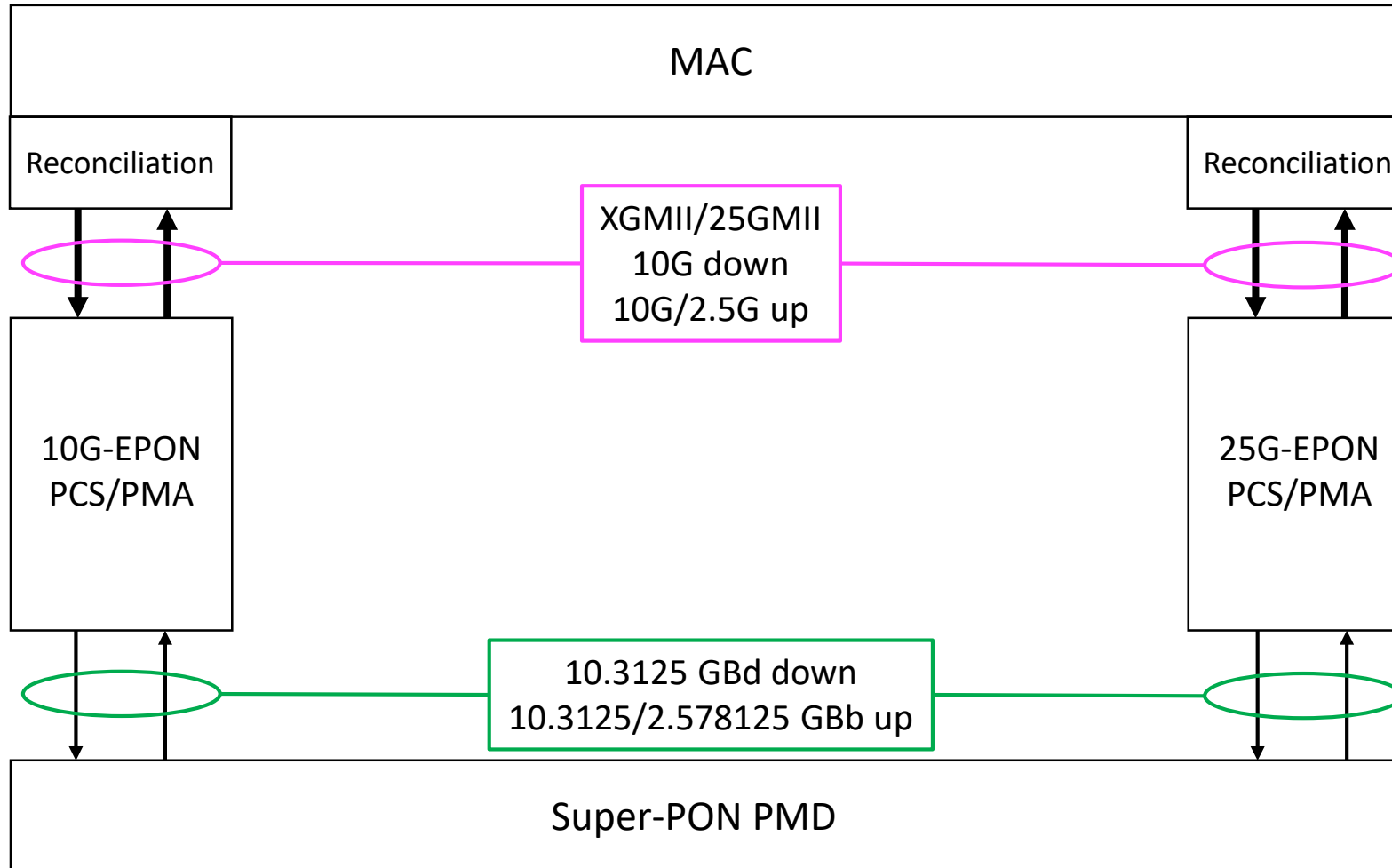

PCS Proposal

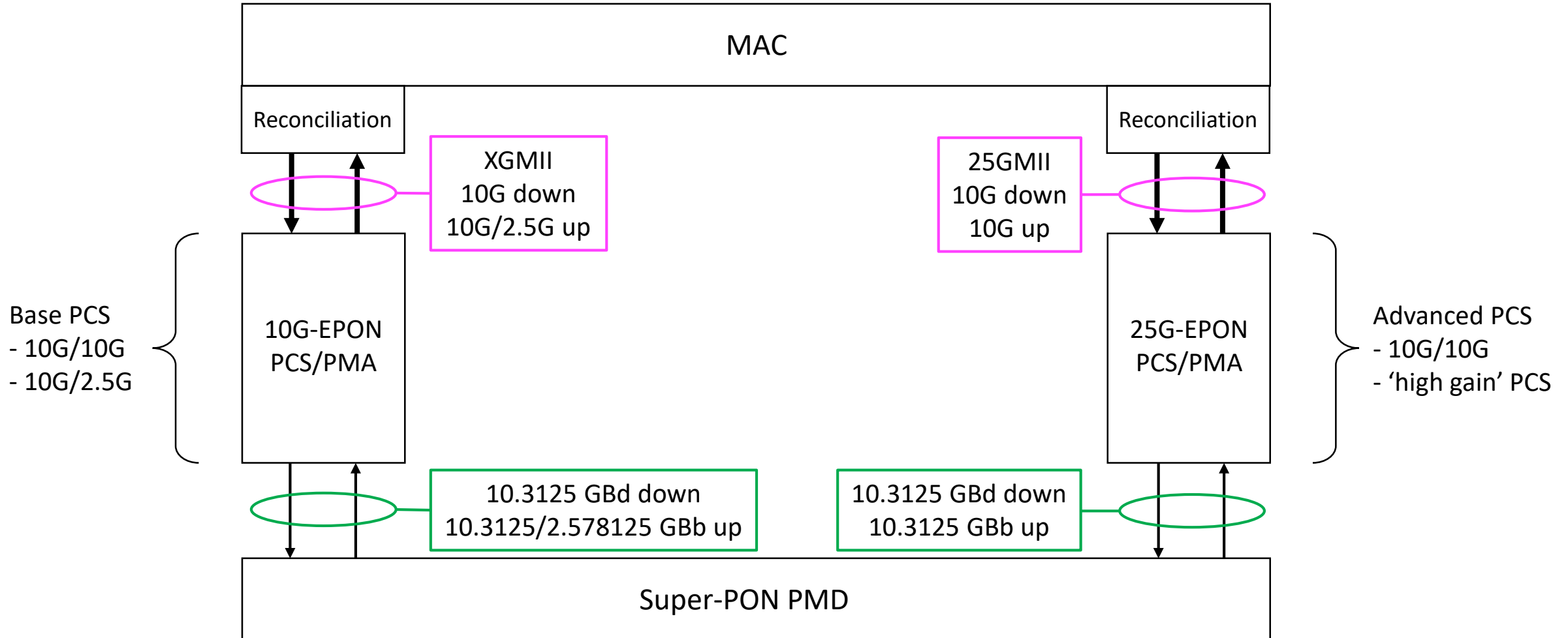

Agenda

- Super-PON PCS Options Review
- Super-PON with 10G-EPON PCS
- Super-PON with 25G-EPON PCS

2.5G-EPON from 10G-EPON

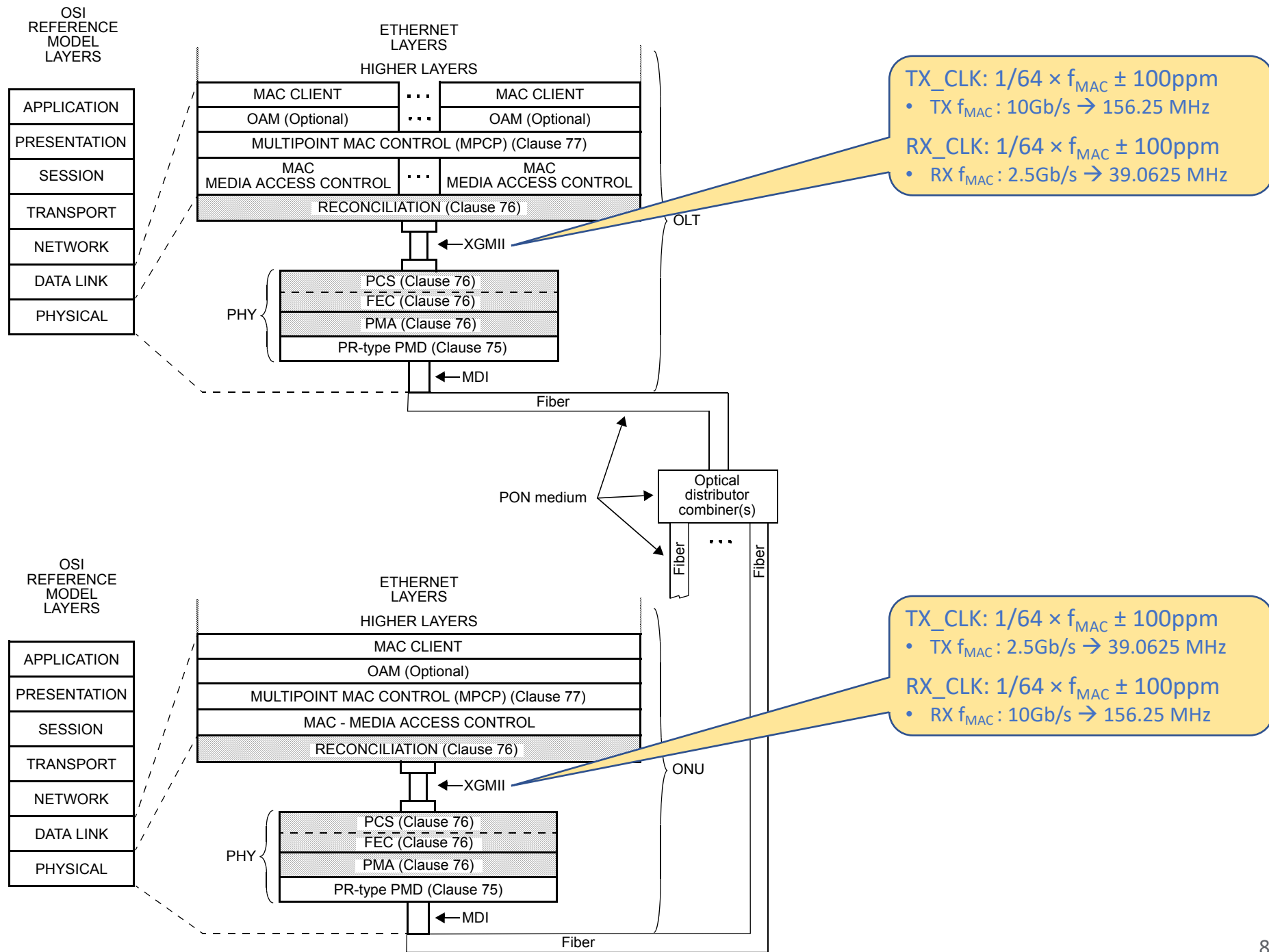

Super-PON PCS from 10G-EPON

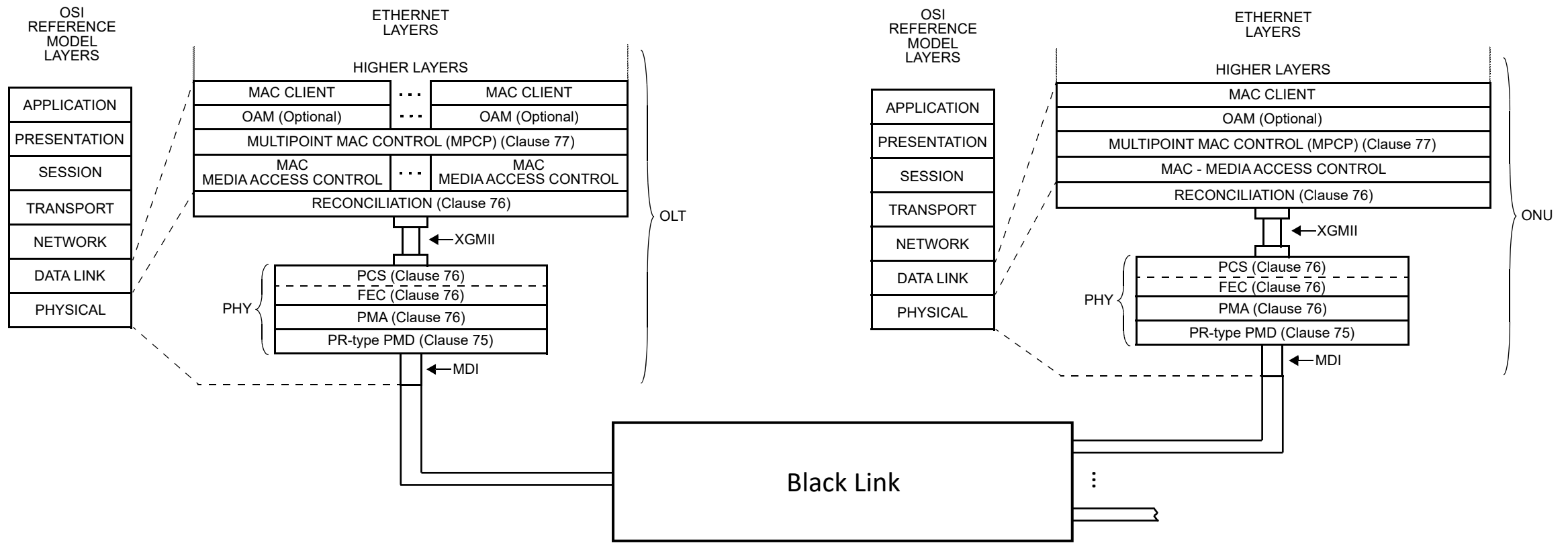

10G-EPON Discovery

- Leverage the discovery GATE MPCPDU

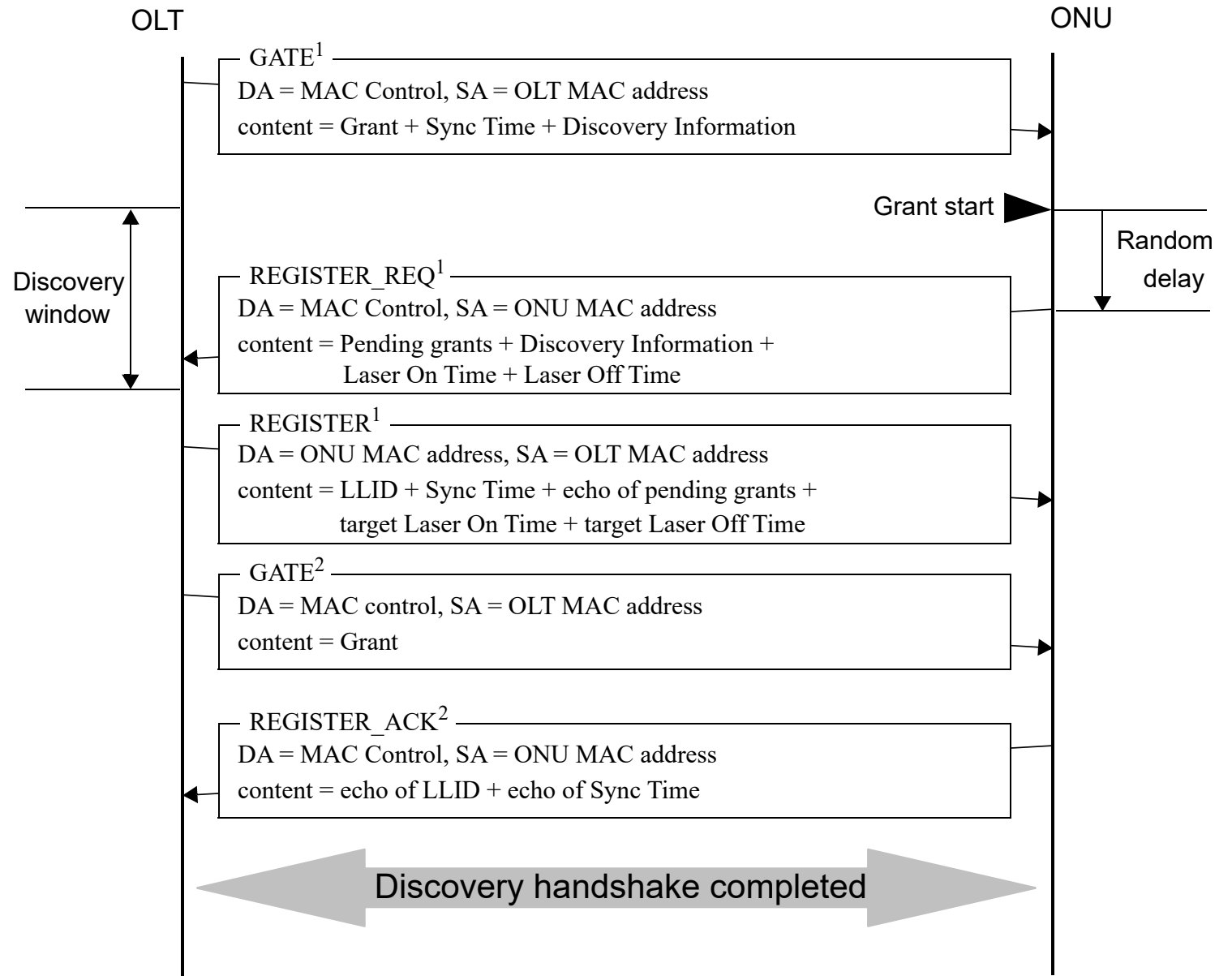

¹ Messages sent on a broadcast channel

² Messages sent on unicast channels

Figure 77-15—Discovery handshake message exchange

GATE MPCPDU

- Leverage the Discovery Information field

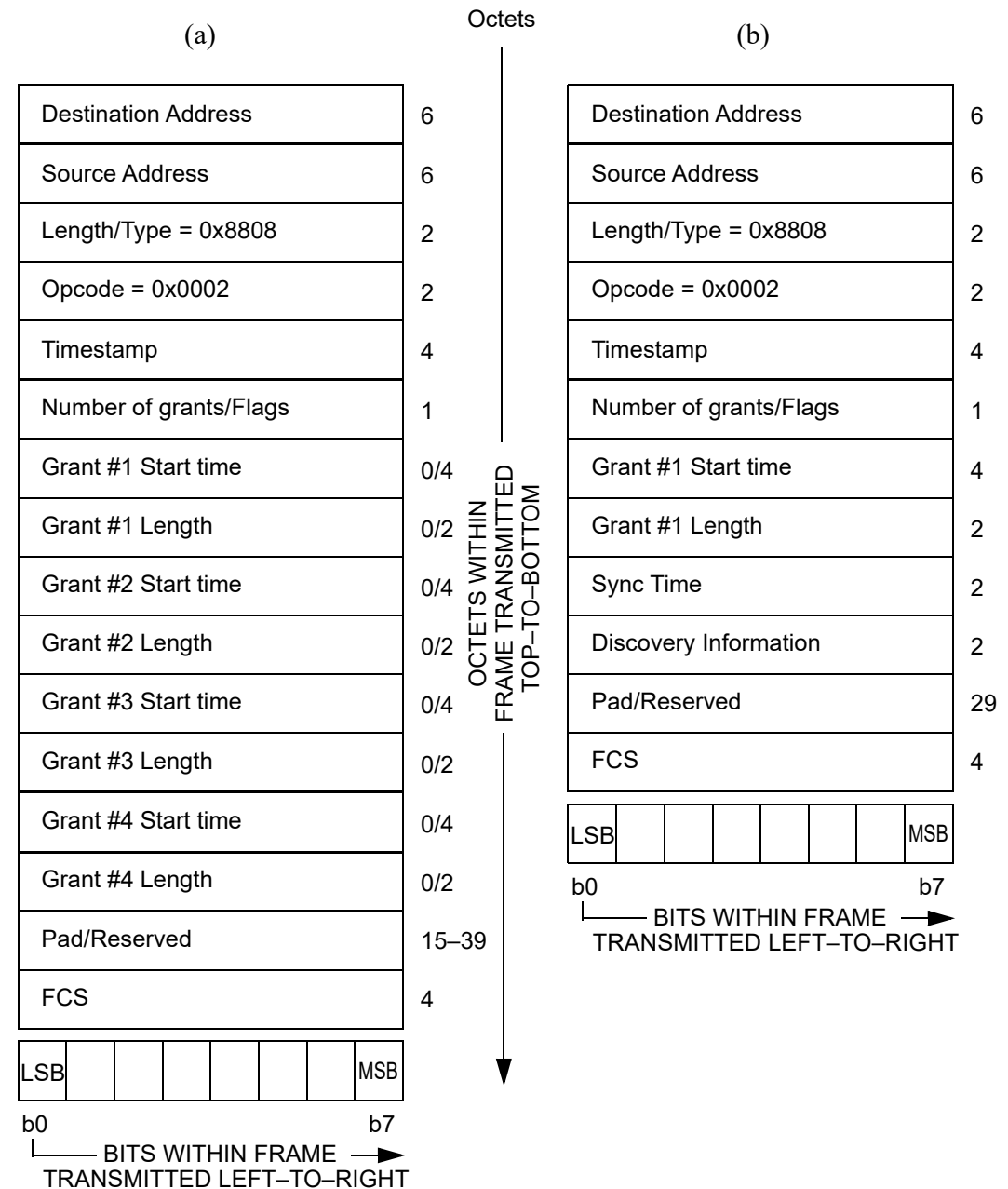

Figure 77-32—GATE MPCPDU: (a) normal GATE MPCPDU, (b) discovery GATE MPCPDU

GATE MPCPDU Discovery Information Field

Table 77–3—GATE MPCPDU discovery information fields

Bit	Flag field	Values
0	OLT is 1G upstream capable	0 – OLT does not support 1 Gb/s reception 1 – OLT supports 1 Gb/s reception
1	OLT is 10G upstream capable	0 – OLT does not support 10 Gb/s reception 1 – OLT supports 10 Gb/s reception
2–3	Reserved	Ignored on reception
4	OLT is opening 1G discovery window	0 – OLT cannot receive 1 Gb/s data in this window 1 – OLT can receive 1 Gb/s data in this window
5	OLT is opening 10G discovery window	0 – OLT cannot receive 10 Gb/s data in this window 1 – OLT can receive 10 Gb/s data in this window
6–15	Reserved	Ignored on reception

Updated GATE MPCPDU Discovery Information

Updated GATE MPCPDU discovery information fields

Bit	Flag field	Values	
10G-EPON Parameters	0	OLT is 1G upstream capable	0 – OLT does not support 1 Gb/s reception 1 – OLT supports 1 Gb/s reception
	1	OLT is 10G upstream capable	0 – OLT does not support 10 Gb/s reception 1 – OLT supports 10 Gb/s reception
	2	OLT is 2.5G upstream capable	0 – OLT does not support 2.5 Gb/s reception 1 – OLT supports 2.5 Gb/s reception
	3	Reserved	Ignored on reception
10G-EPON Parameters	4	OLT is opening 1G discovery window	0 – OLT cannot receive 1 Gb/s data in this window 1 – OLT can receive 1 Gb/s data in this window
	5	OLT is opening 10G discovery window	0 – OLT cannot receive 10 Gb/s data in this window 1 – OLT can receive 10 Gb/s data in this window
	6	OLT is opening 2.5G discovery window	0 – OLT cannot receive 2.5 Gb/s data in this window 1 – OLT can receive 2.5 Gb/s data in this window
	7-11	Reserved	Ignored on reception
	12-15	Channel information	Encodes the channel number the OLT is operating on

Super-PON Parameters

Super-PON Parameters

Super-PON Parameters

REGISTER_REQ MPCPDU

Table 77-6—REGISTER_REQ MPCPDU Discovery Information Fields

Bit	Flag field	Values
0	ONU is 1G upstream capable	0 – ONU transmitter is not capable of 1 Gb/s 1 – ONU transmitter is capable of 1 Gb/s
1	ONU is 10G upstream capable	0 – ONU transmitter is not capable of 10 Gb/s 1 – ONU transmitter is capable of 10 Gb/s
2–3	Reserved	Ignored on reception
4	1G registration attempt	0 – 1 Gb/s registration is not attempted 1 – 1 Gb/s registration is attempted
5	10G registration attempt	0 – 10 Gb/s registration is not attempted 1 – 10 Gb/s registration is attempted
6–15	Reserved	Ignored on reception

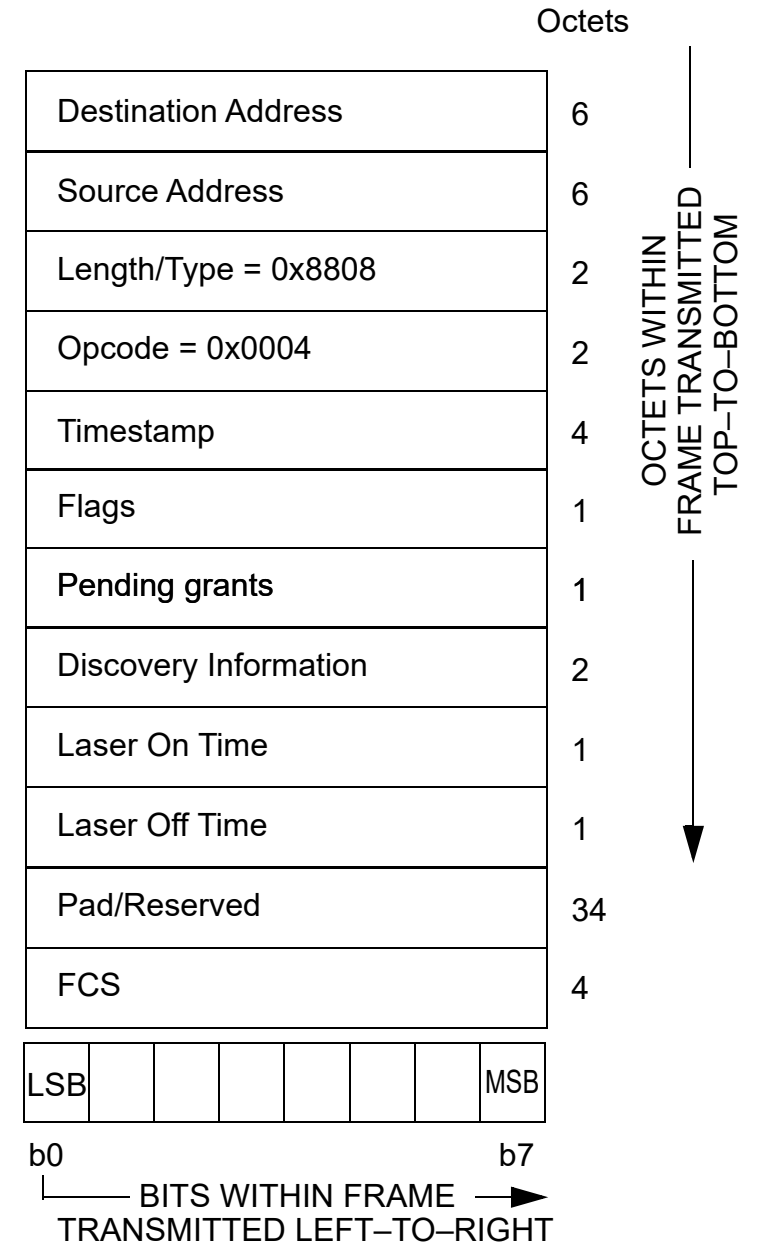

Figure 77-34—REGISTER_REQ MPCPDU

Updated REGISTER_REQ MPCPDU Discovery Information

Updated REGISTER_REQ MPCPDU discovery information fields

Bit	Flag field	Values		
10G-EPON Parameters	0	ONU is 1G upstream capable	0 – ONU transmitter is not capable of 1 Gb/s 1 – ONU transmitter is capable of 1 Gb/s	Super-PON Parameters
	1	ONU is 10G upstream capable	0 – ONU transmitter is not capable of 10 Gb/s 1 – ONU transmitter is capable of 10 Gb/s	
	2	ONU is 2.5G upstream capable	0 – ONU transmitter is not capable of 2.5 Gb/s 1 – ONU transmitter is capable of 2.5 Gb/s	
10G-EPON Parameters	3	Reserved	Ignored on reception	Super-PON Parameters
	4	1G registration attempt	0 – ONU transmitter is not capable of 1 Gb/s 1 – ONU transmitter is capable of 1 Gb/s	
	5	10G registration attempt	0 – ONU transmitter is not capable of 10 Gb/s 1 – ONU transmitter is capable of 10 Gb/s	
	6	2.5G registration attempt	0 – ONU transmitter is not capable of 2.5 Gb/s 1 – ONU transmitter is capable of 2.5 Gb/s	
	7-15	Reserved	Ignored on reception	

Agenda

- Super-PON PCS Options Review
- Super-PON with 10G-EPON PCS
- Super-PON with 25G-EPON PCS

10G-EPON from 25G-EPON

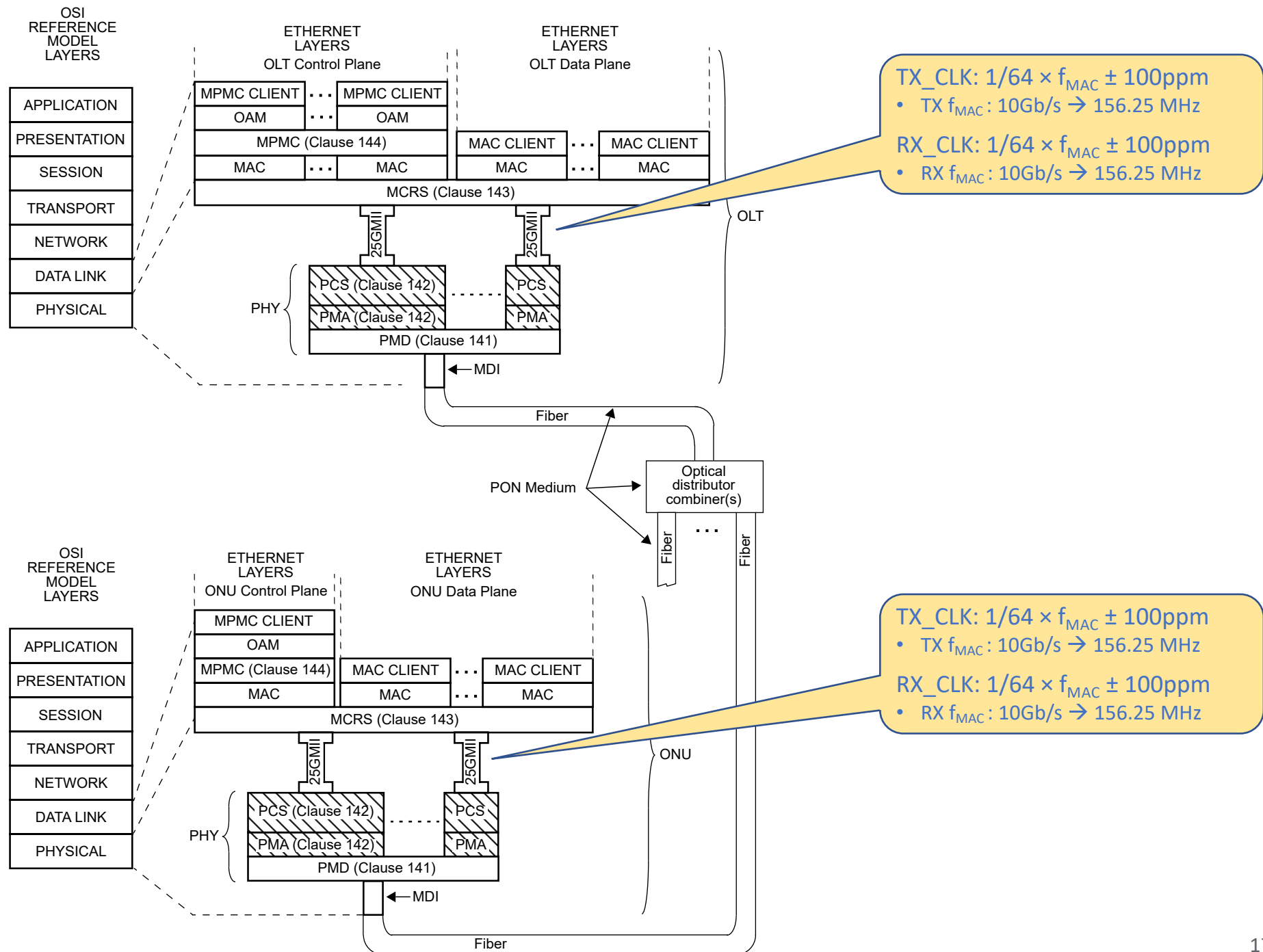

Super-PON PCS from 25G-EPON

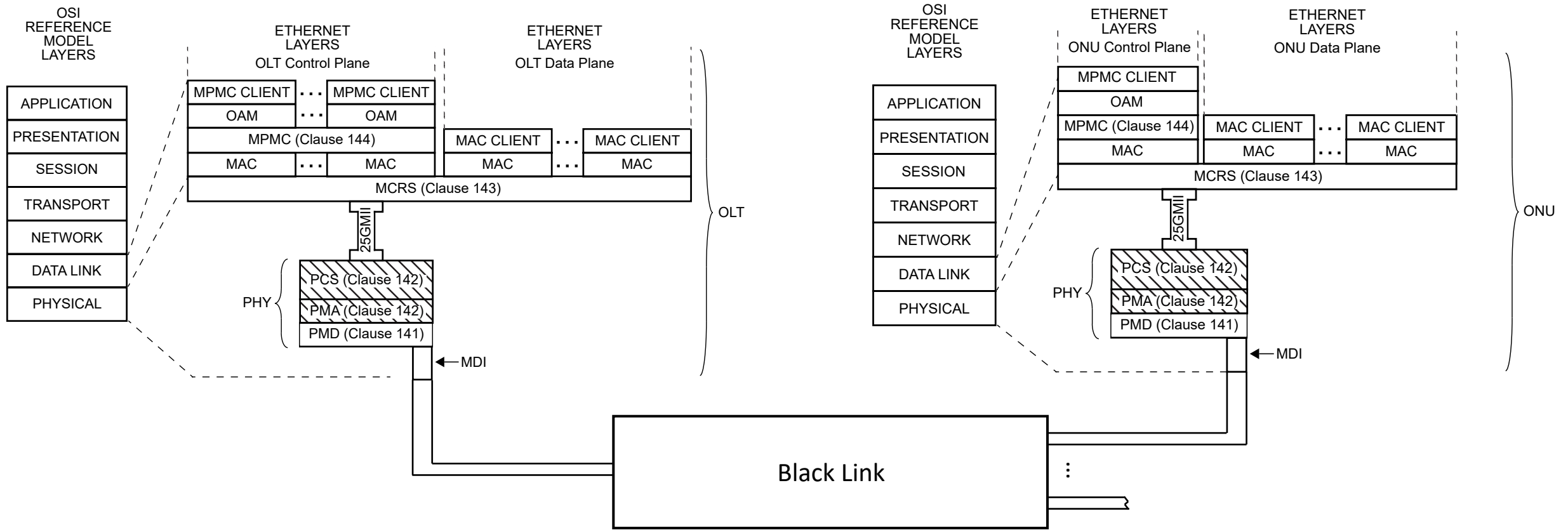

25G-EPON Discovery

- Leverage the DISCOVERY MPCPDU

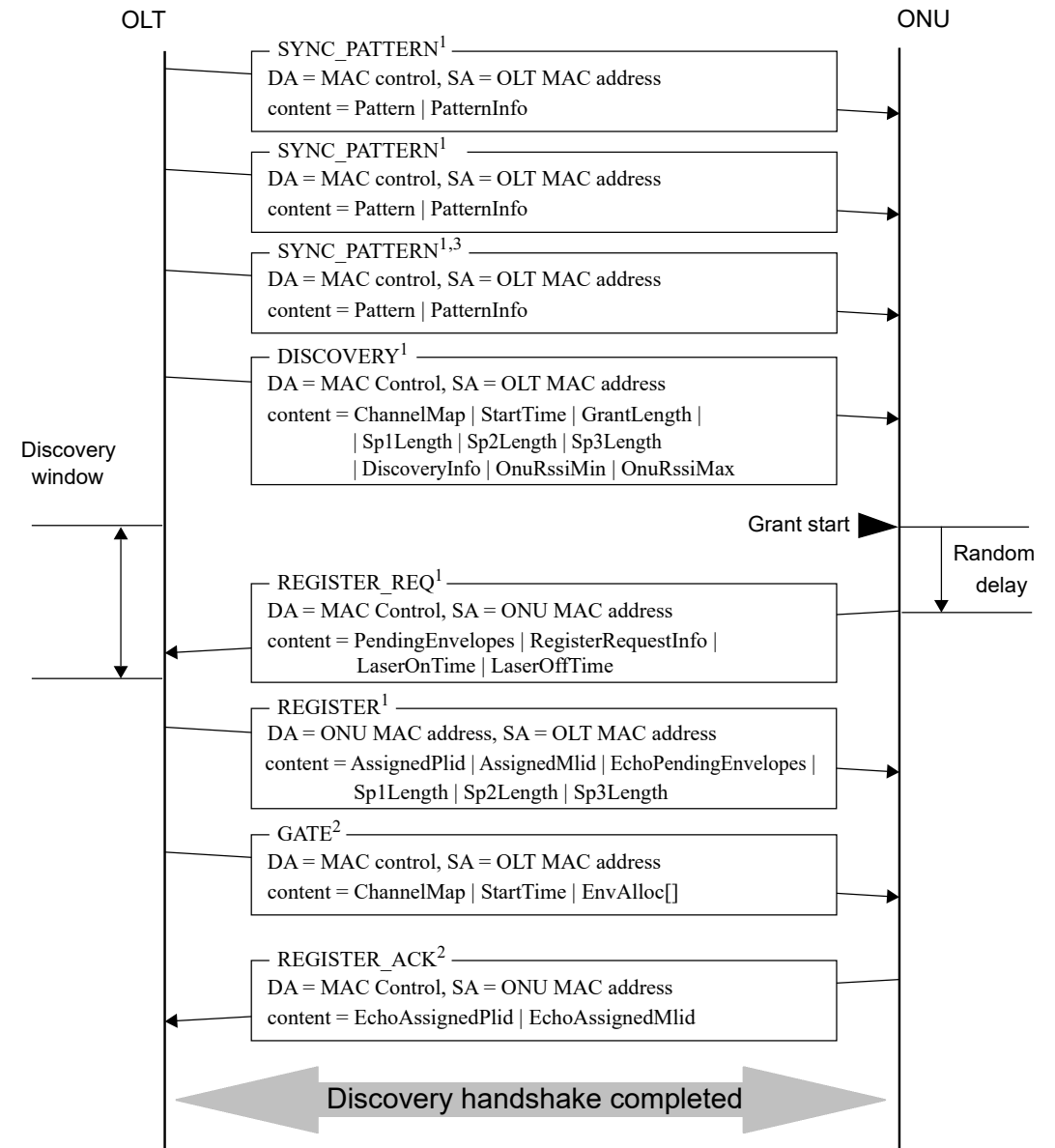

¹ Messages sent on discovery PLID (DISC_PLID)

² Messages sent on unicast PLID

³ Present only when *Count* in SYNC_PATTERN MPCPDU is equal to 3

DISCOVERY MPCPDU

- Leverage the DiscoveryInfo field

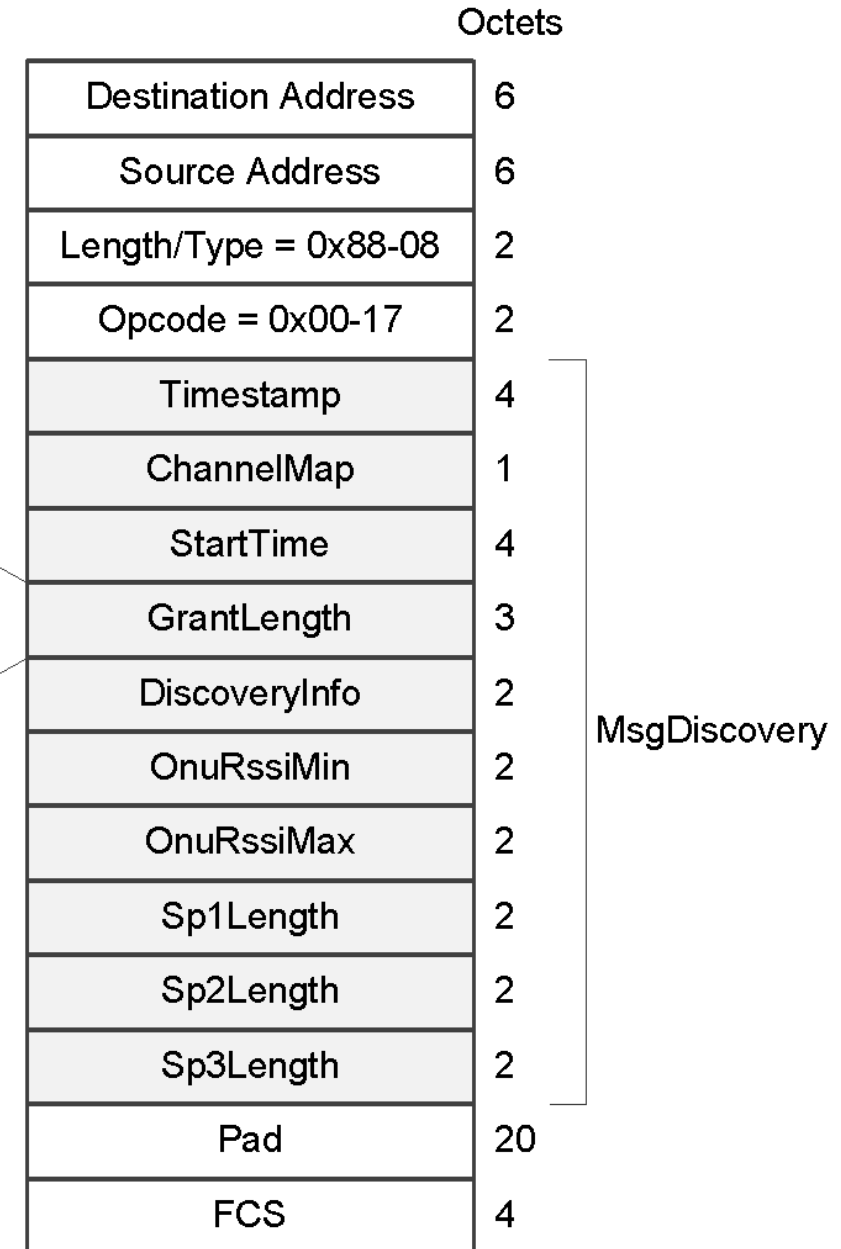
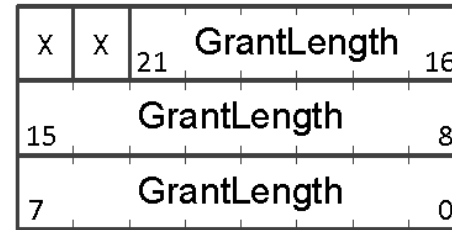

Figure 144-17—DISCOVERY MPCPDU

DiscoveryInfo Field

Table 144–7—DiscoveryInfo field

Bit	Flag field	Values
0	Reserved	Ignored on Reception
1	OLT is 10G upstream capable	0 – OLT does not support 10 Gb/s reception 1 – OLT supports 10 Gb/s reception
2	OLT is 25G upstream capable	0 – OLT does not support 25 Gb/s reception 1 – OLT supports 25 Gb/s reception
3-4	Reserved	Ignored on Reception
5	OLT is opening 10G discovery window	0 – OLT cannot receive 10 Gb/s data in this window 1 – OLT can receive 10 Gb/s data in this window
6	OLT is opening 25G discovery window	0 – OLT cannot receive 25 Gb/s data in this window 1 – OLT can receive 25 Gb/s data in this window
7-13	Reserved	Ignored on Reception
14	Coexistence class G	0 – ONUs supporting PMDs coexistence class G are not allowed to register 1 – ONUs supporting PMDs coexistence class G are allowed to register
15	Coexistence class X	0 – ONUs supporting PMDs coexistence class X are not allowed to register 1 – ONUs supporting PMDs coexistence class X are allowed to register

Updated DiscoveryInfo Field

Updated DiscoveryInfo field

Bit	Flag field	Values		
0	Reserved	Ignored on reception		
25G-EPON Parameters	1	OLT is 10G upstream capable	0 – OLT does not support 10 Gb/s reception 1 – OLT supports 10 Gb/s reception	} Super-PON Parameters
	2	OLT is 25G upstream capable	0 – OLT does not support 25 Gb/s reception 1 – OLT supports 25 Gb/s reception	
	3-4	Reserved	Ignored on reception	
25G-EPON Parameters	5	OLT is opening 10G discovery window	0 – OLT cannot receive 10 Gb/s data in this window 1 – OLT can receive 10 Gb/s data in this window	} Super-PON Parameters
	6	OLT is opening 25G discovery window	0 – OLT cannot receive 25 Gb/s data in this window 1 – OLT can receive 25 Gb/s data in this window	
	7-9	Reserved	Ignored on reception	
	10-13	Channel information	Encodes the channel number the OLT is operating on	} Super-PON Parameters
	14	Coexistence class G	0 – ONUs supporting PMDs coexistence class G are not allowed to register 1 – ONUs supporting PMDs coexistence class G are allowed to register	
	15	Coexistence class X	0 – ONUs supporting PMDs coexistence class X are not allowed to register 1 – ONUs supporting PMDs coexistence class X are allowed to register	

REGISTER_REQ MPCPDU

Table 144-4—RegisterRequestInfo field

Bit	Flag field	Values
0	Reserved	Ignored on Reception
1	ONU is 10G upstream capable	0 – ONU transmitter is not capable of 10 Gb/s 1 – ONU transmitter is capable of 10 Gb/s
2	ONU is 25G upstream capable	0 – ONU transmitter is not capable of 25 Gb/s 1 – ONU transmitter is capable of 25 Gb/s
3-4	Reserved	Ignored on Reception
5	10G registration attempt	0 - 10 Gb/s registration is not attempted 1 - 10 Gb/s registration is attempted
6	25G registration attempt	0 - 25 Gb/s registration is not attempted 1 - 25 Gb/s registration is attempted
7-15	Reserved	Ignored on Reception

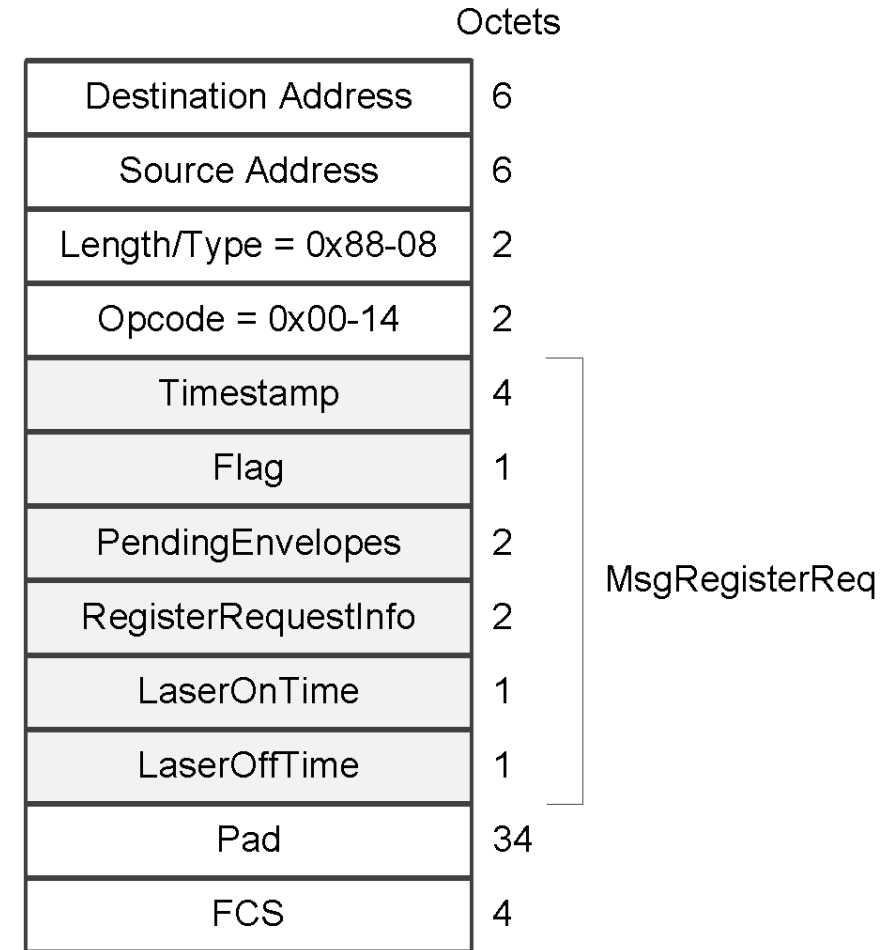

Figure 144-14—REGISTER_REQ MPCPDU

Summary

- This contribution proposes to define two PCS options for P802.3cs
 - Something like 100GBASE-R (64/66) and RS-FEC 100GBASE-R (256/257)
- Base PCS
 - Based on 64/66 10G-EPON PCS (clause 76)
 - Supports the symmetric 10G/10G and asymmetric 10G/2.5G speeds
 - Allows sharing IEEE P802.3cs PMDs with the ITU-T G.9807.3 'Super-PON' project
 - That will leverage the XGS-PON TC Layer
- Advanced PCS
 - Based on 256/257 25G-EPON PCS (clause 142)
 - Supports only the symmetric 10G/10G speed
 - Useful for higher ODN loss scenarios
 - Makes more 'future-proof' the P802.3cs project

Comments?

Thank you!