

802.3da Compensated T / TCI Measurements

Stephan Schreiner, Rosenberger Hochfrequenztechnik GmbH & Co. KG
March 2024

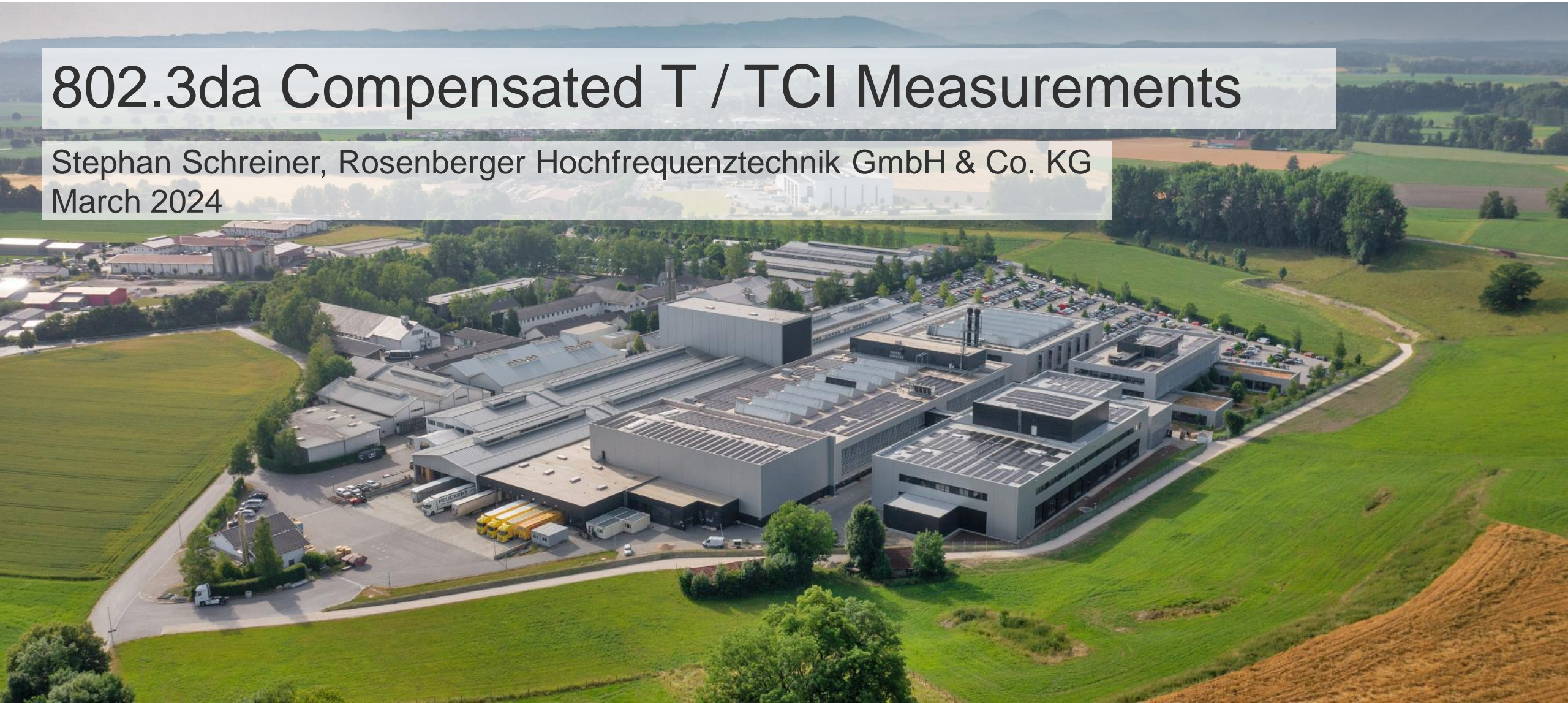

- Purpose

- Presentation of measurement values of different „T“ type implementations for TCI Return Loss and Insertion Loss consideration

- Outline

- Measurement of different „T“ Implementations
 - Measurement Setup
 - Used Loads
 - Measurement Results
- Parameter Variations
 - Overview
 - Capacity
 - Stub Length
 - Temperature

Measurement Setup

Three DUTs are measured

- Multiple measurements collected
 - Different types of „T“
 - Uncompensated (A)
 - SMD inductor compensated (B)
 - Ferrite compensated (C)
 - Different TC3 Connections
 - Open (1)
 - TC3 2 x 50Ω (2)
 - Dummy Load (3)
- VNA setup
 - Calibration Plane on RPC-3.5 Interface
 - Adapter PCB included (not deembedded)
 - Frequency Settings:
 - Start 100 kHz; Stop 200 MHz; Step 100 kHz
 - Differential Pairs: D1(P1, P2), D2(P3,P4)

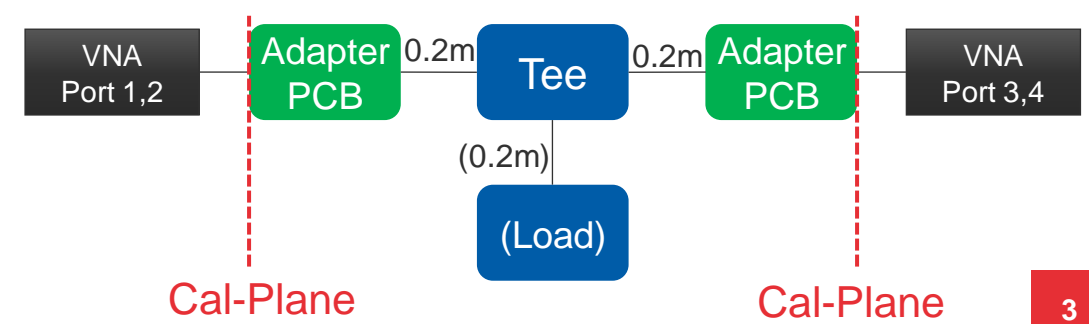
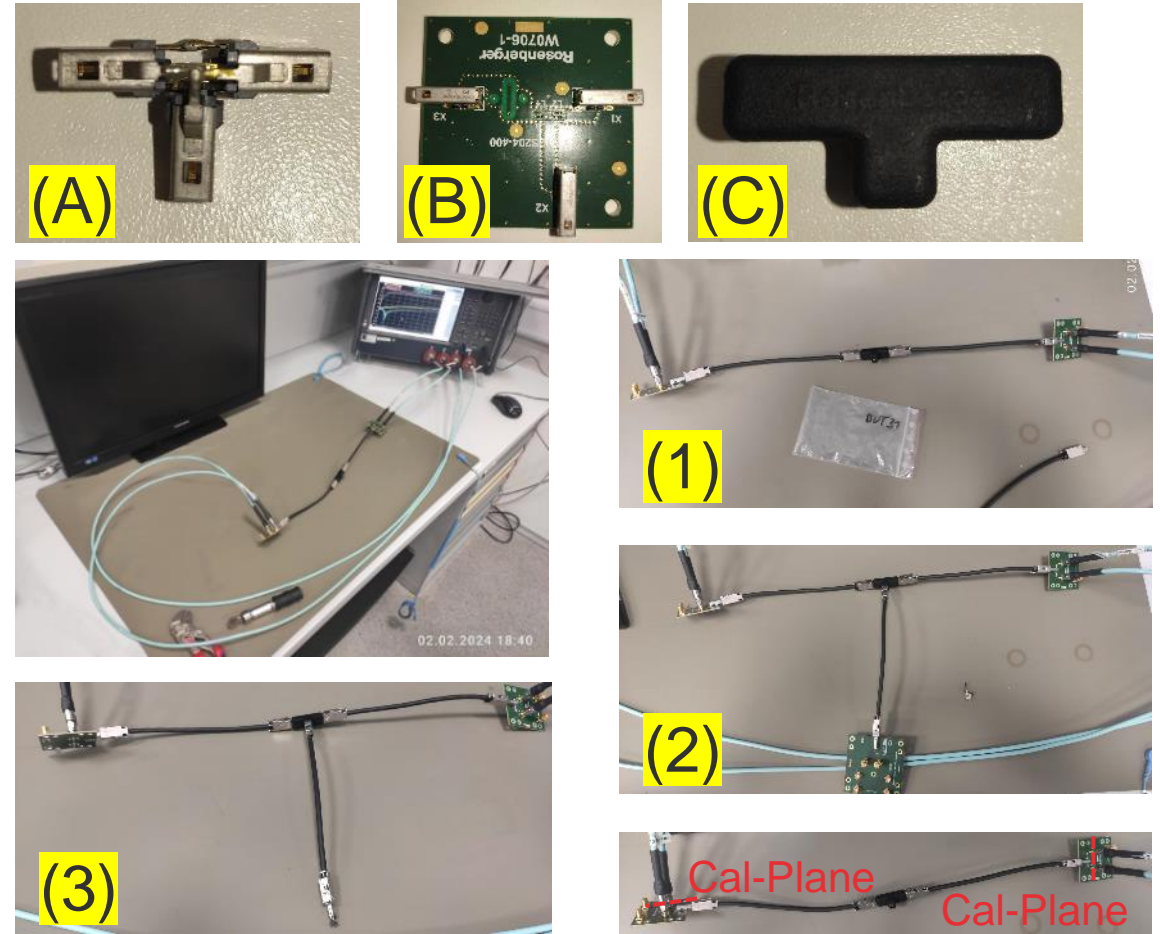

Used Loads

- No Load (1)
 - Nothing connected on TC3
- 2 x 50Ω Load (2)
 - Precision 50Ω Terminations between each inner conductor and shield
- Dummy load (3)
 - 27 pF Capacitor between inner conductors
 - 5100Ω Resistor from each inner conductor to shield
 - 2 x 47μH connected in series between inner conductors

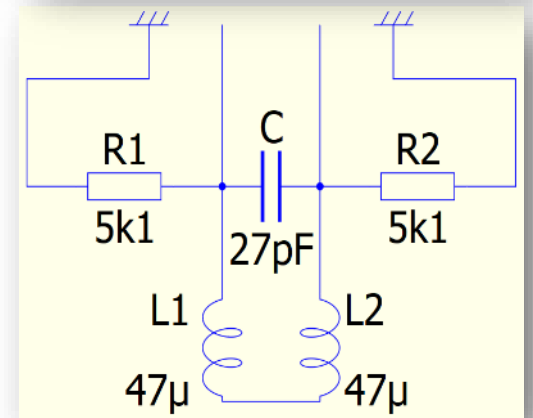
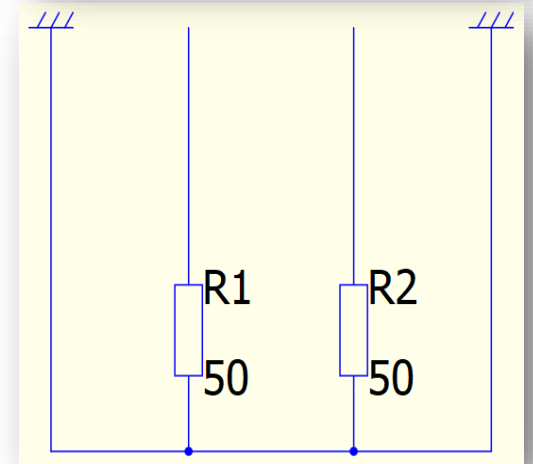
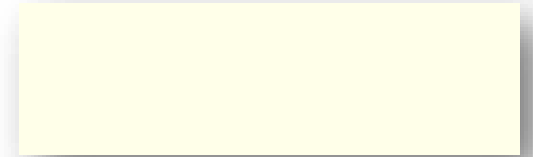
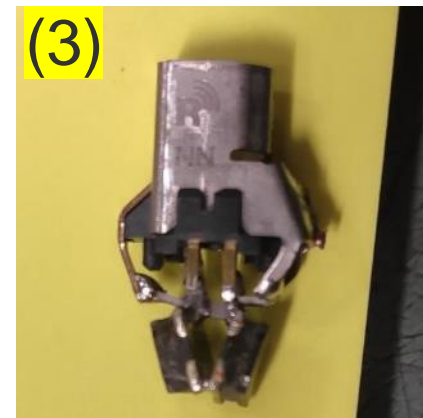

Measurement Values - Overview

Differential Mode (Sdd11, Sdd22, Sdd21)

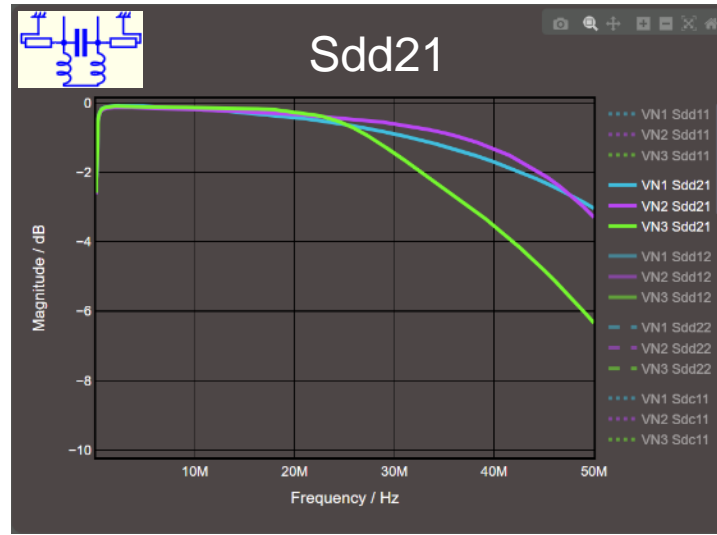
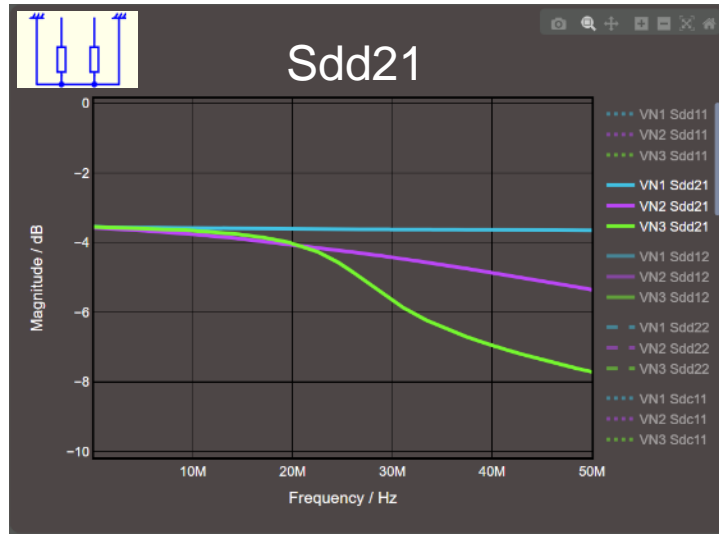
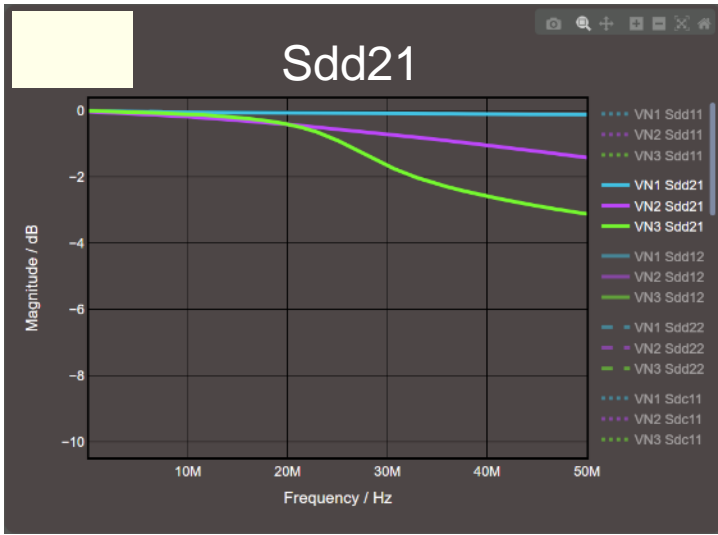
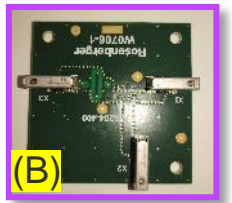
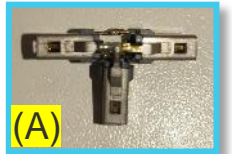
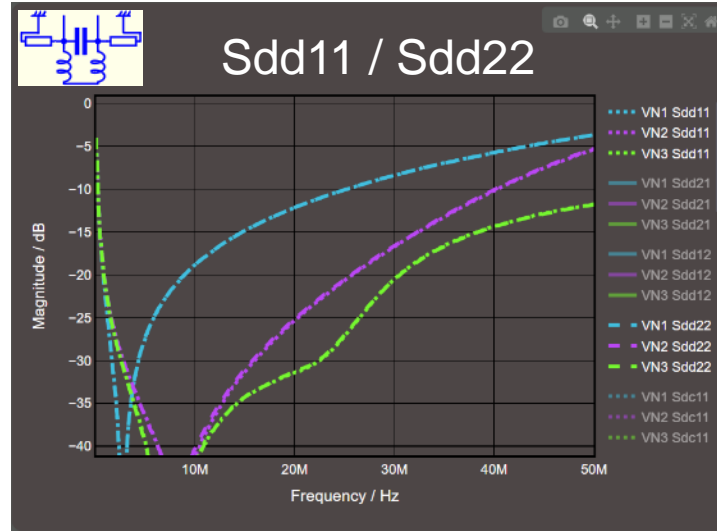
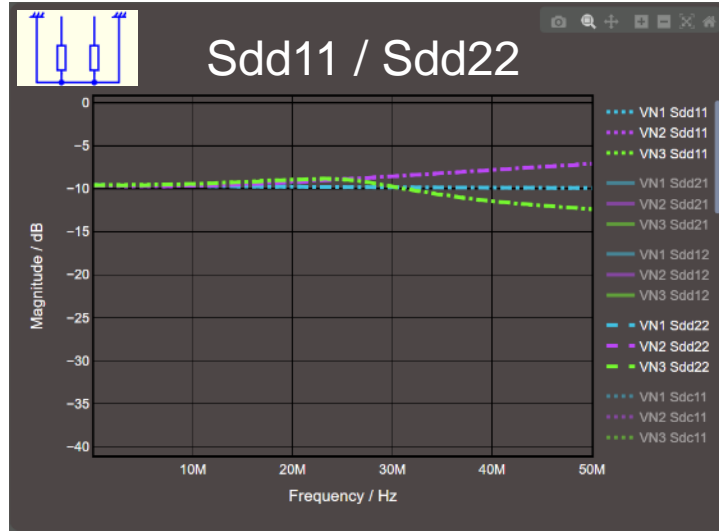
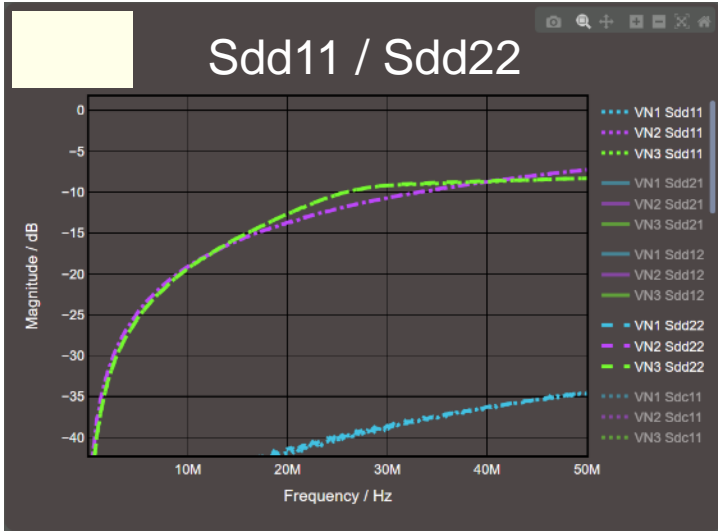

Measurement Values

Common Mode (Scc11, Scc21, Scc22)

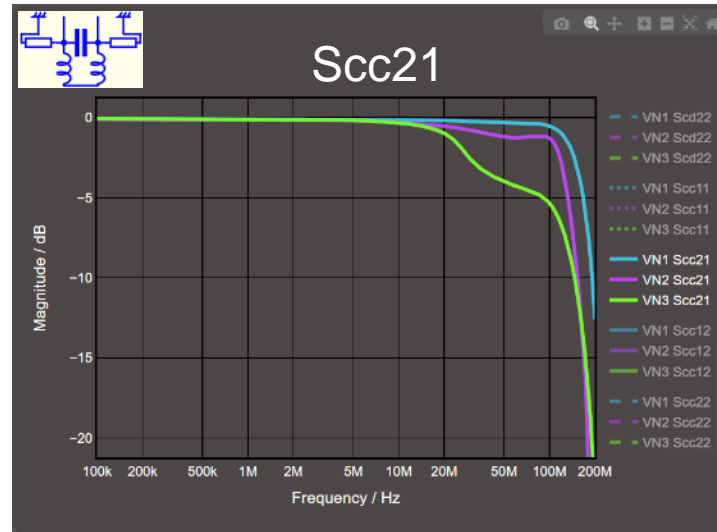
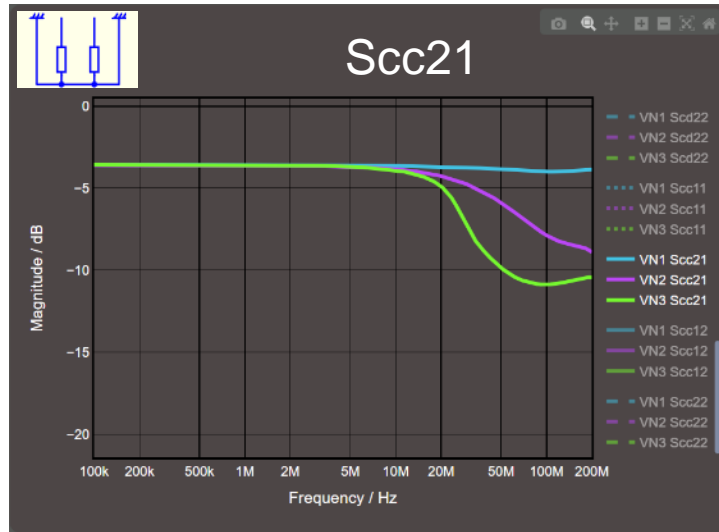
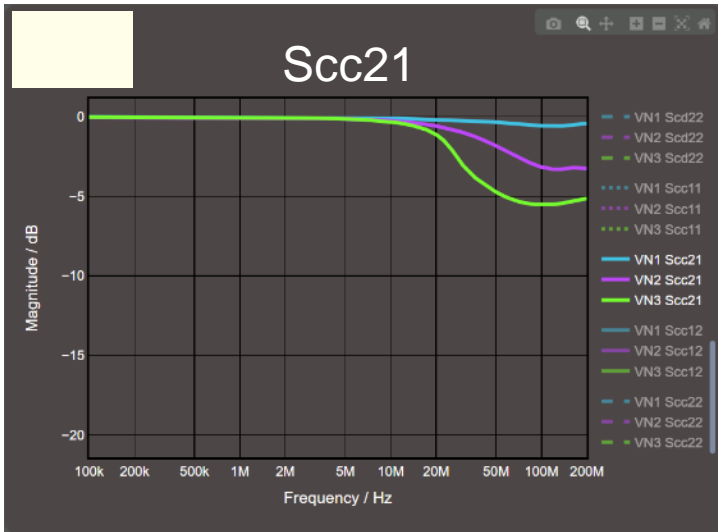
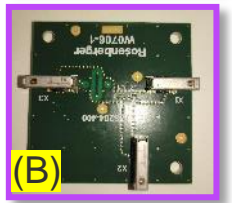
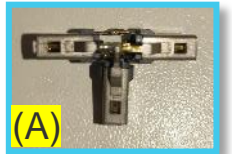
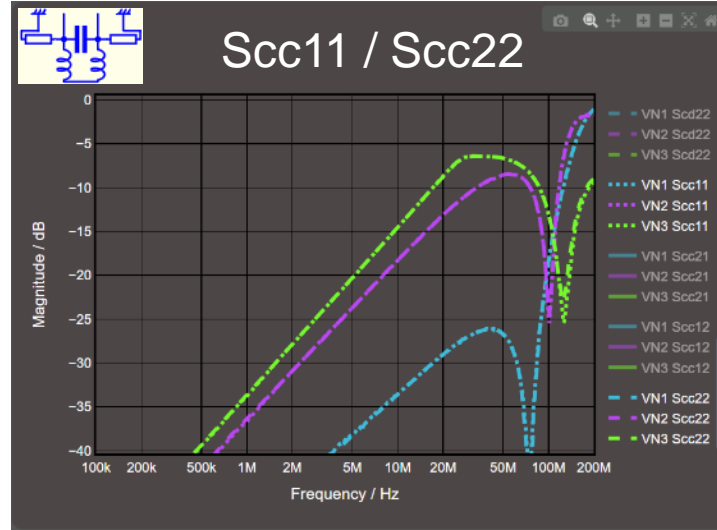
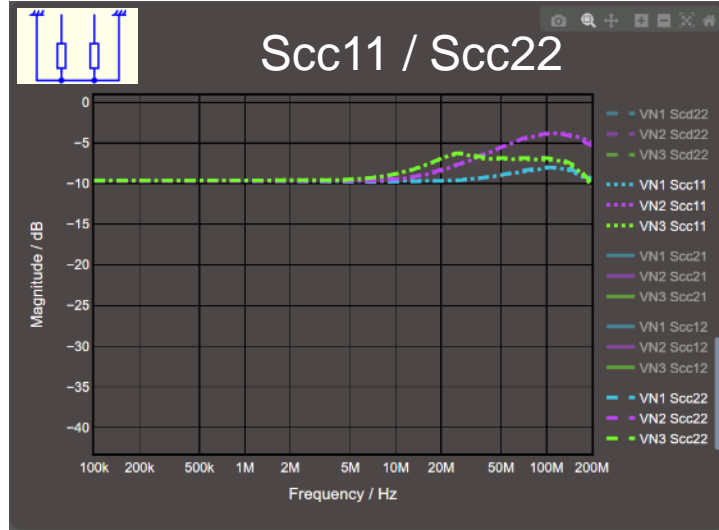
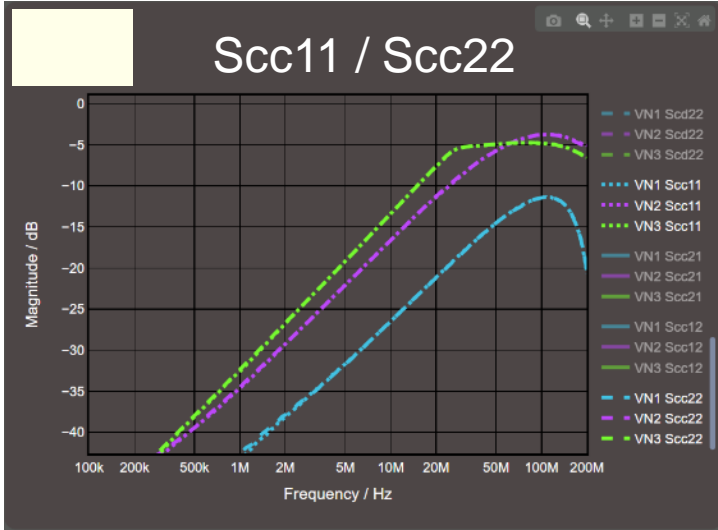

Measurement Values

Mode Conversion (Sdc11, Sdc21, Sdc22)

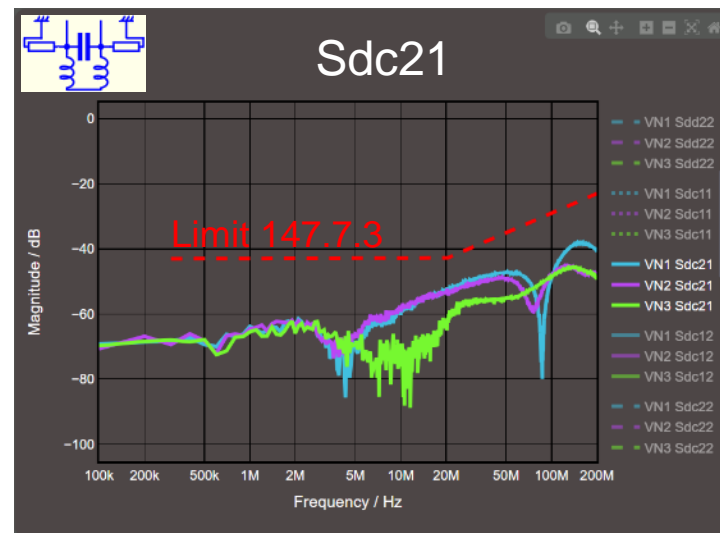
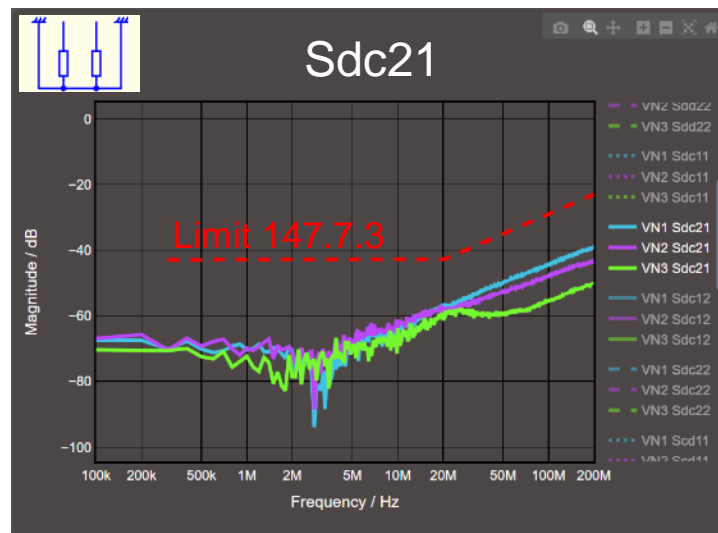
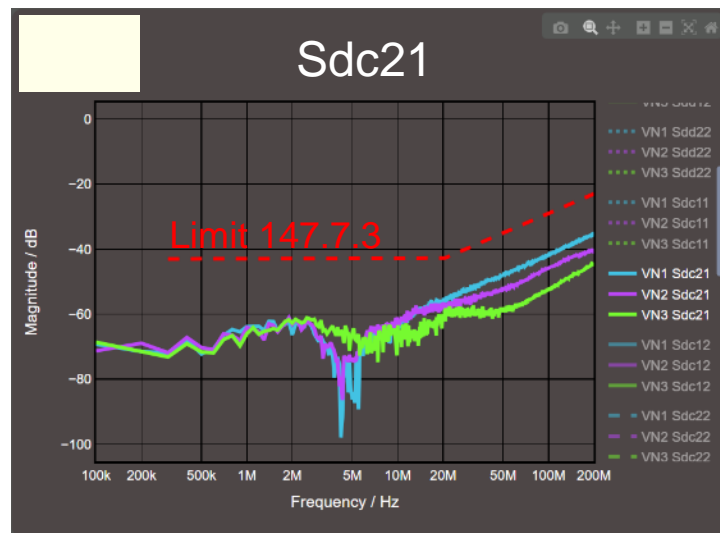
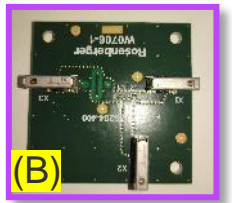
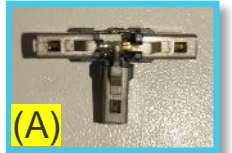
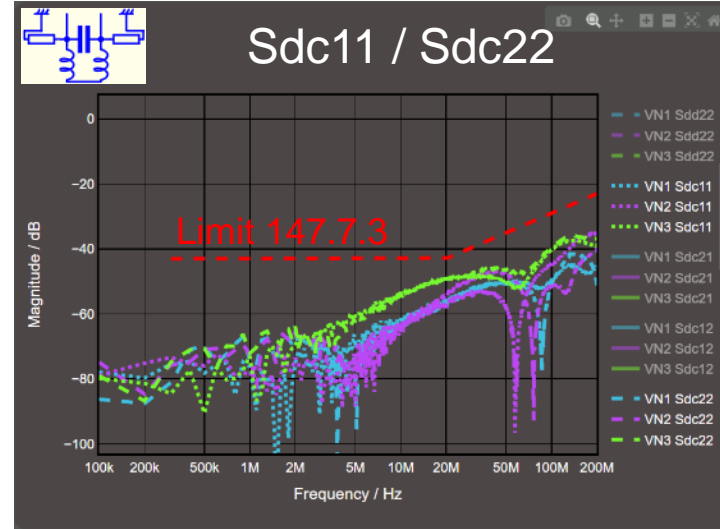
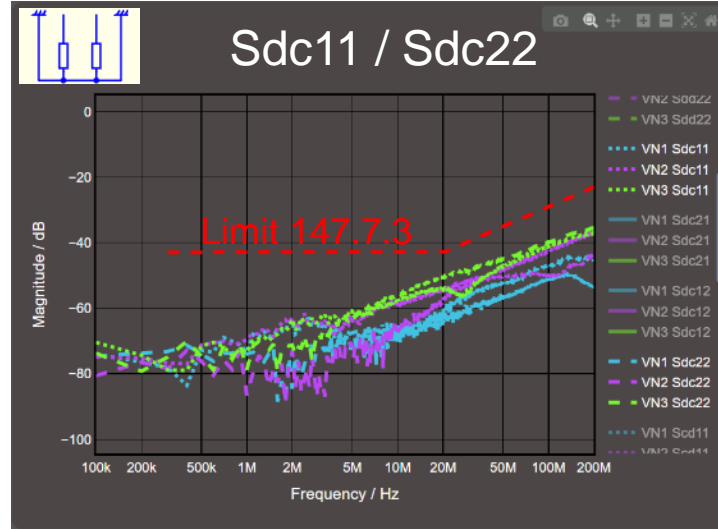
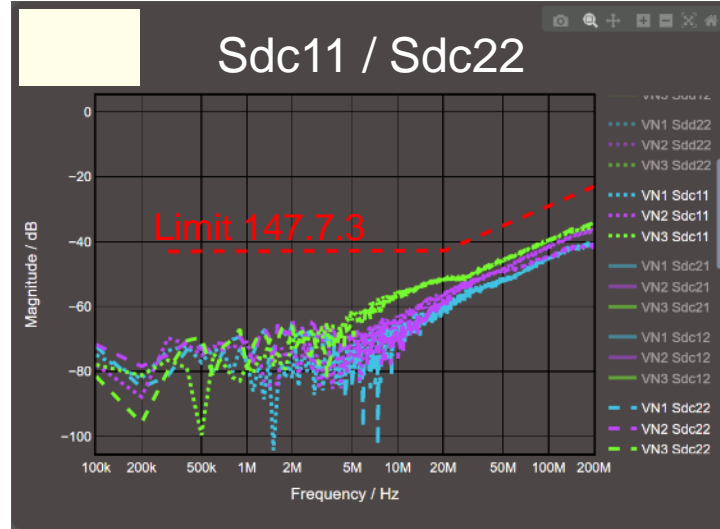

Ferrite Compensated Tee

- Load Variation

- 15 pF – 33 pF Capacitor
- 5100Ω Resistor
- 2 x 47μH Stub Length Variation

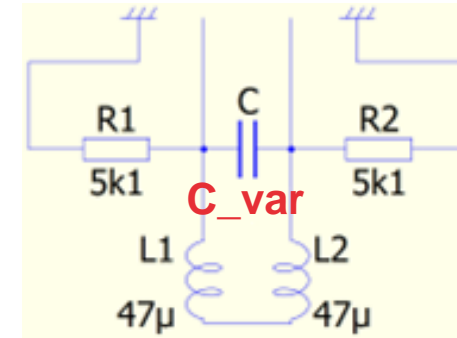

- Stub Length Variation

- Length from 0.1m to 1m

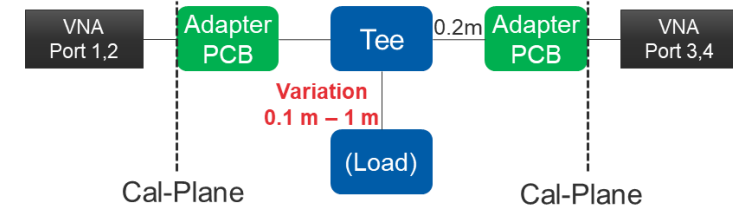

- Temperature Variation

- Temperature from room temperature to 125°C

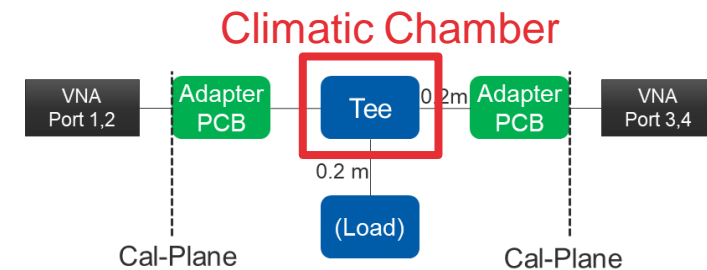

Measurement Values

Capacity Variation

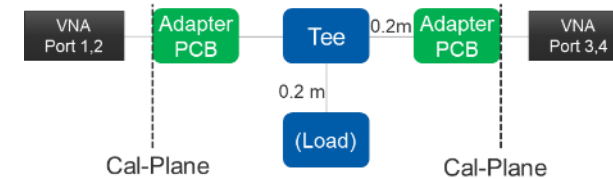
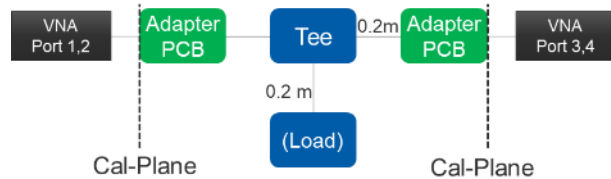
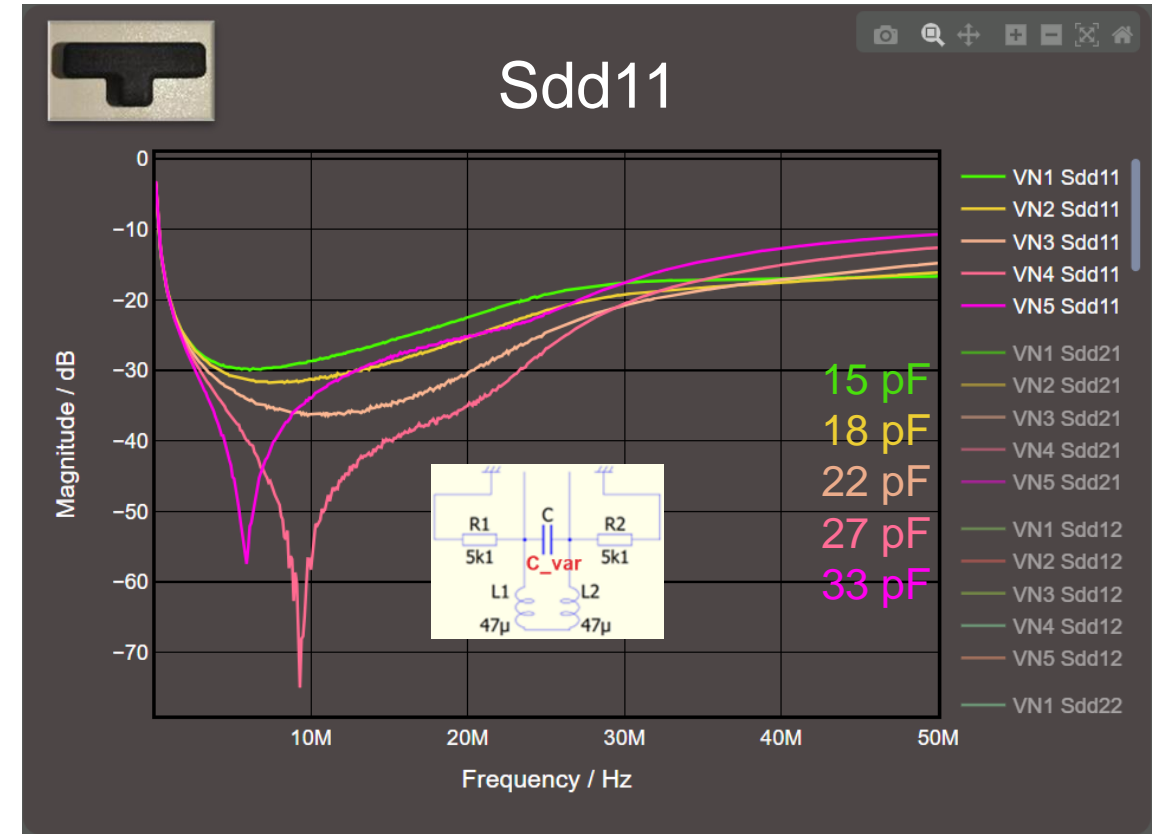
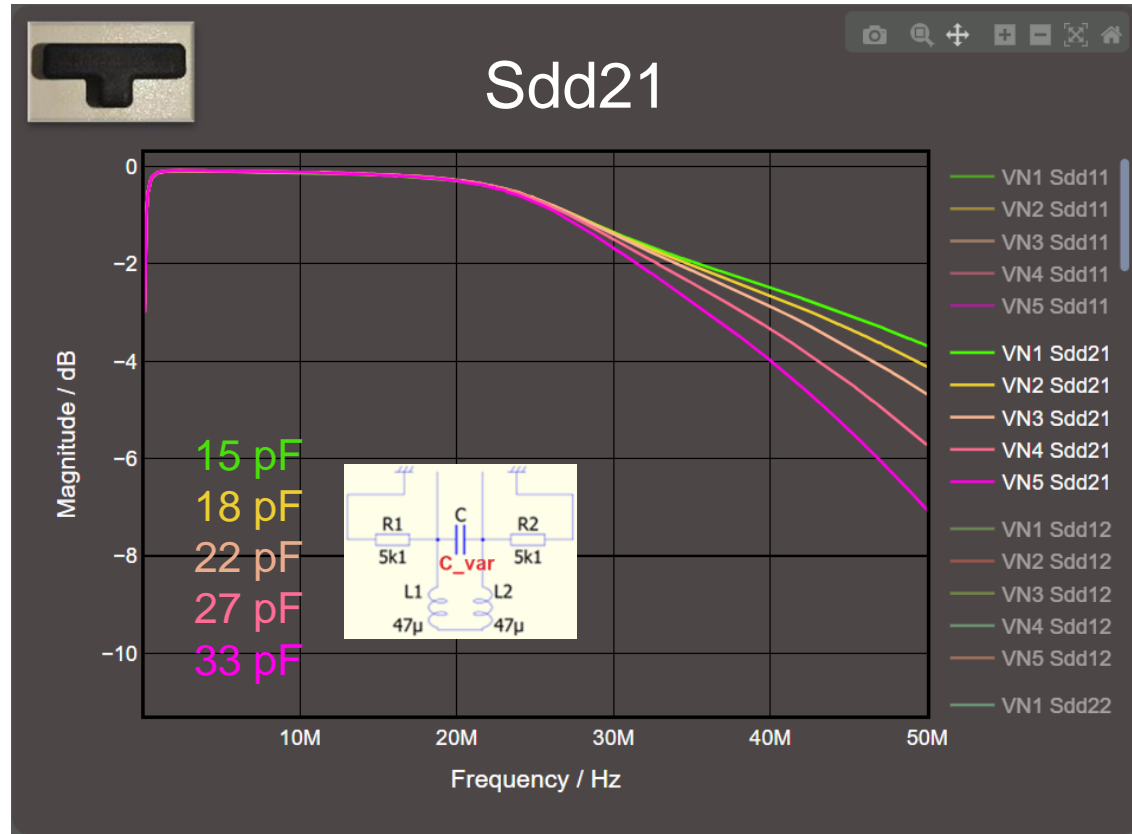

Measurement Values

Stub Length Variation

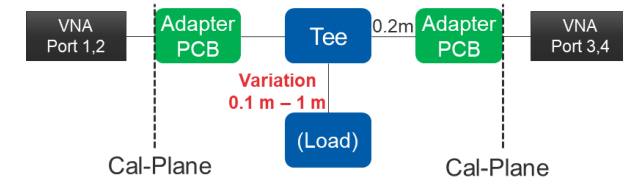
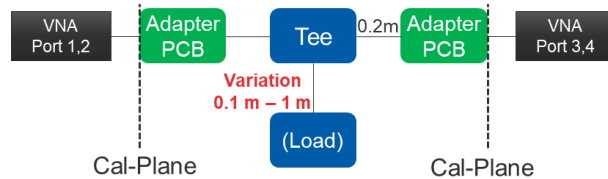
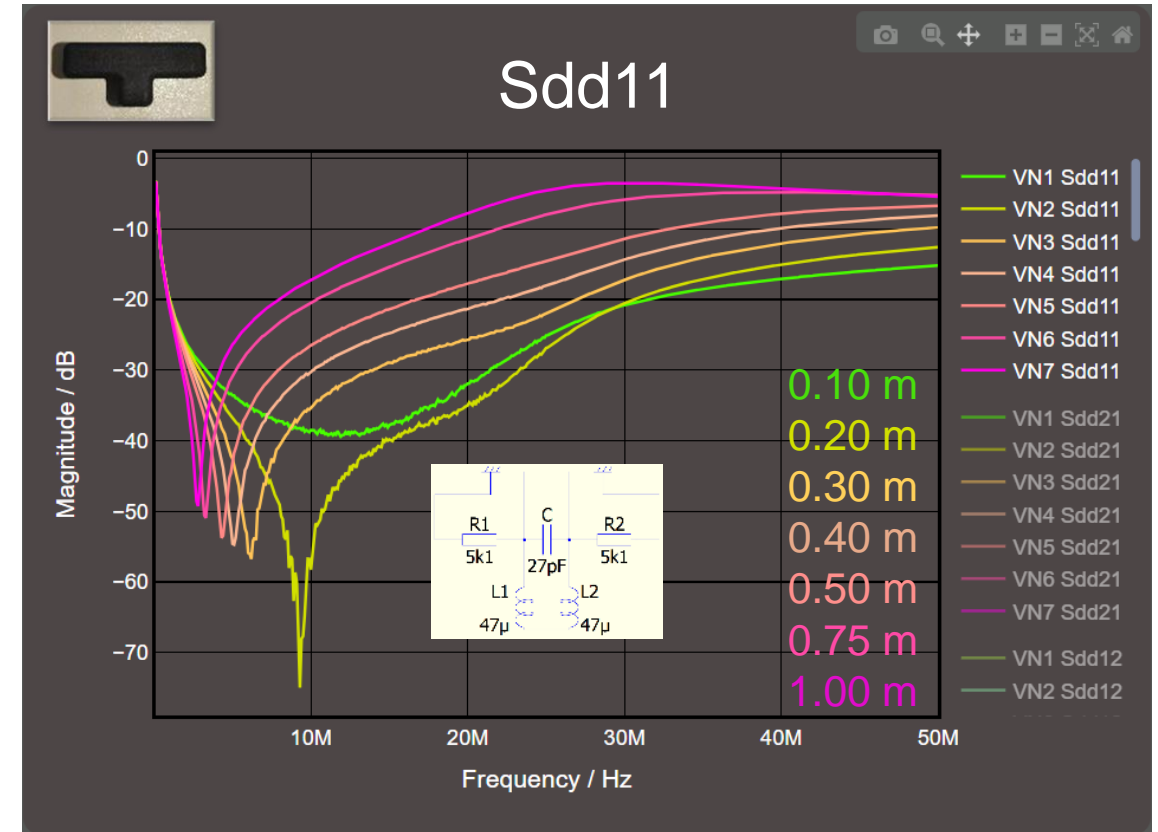
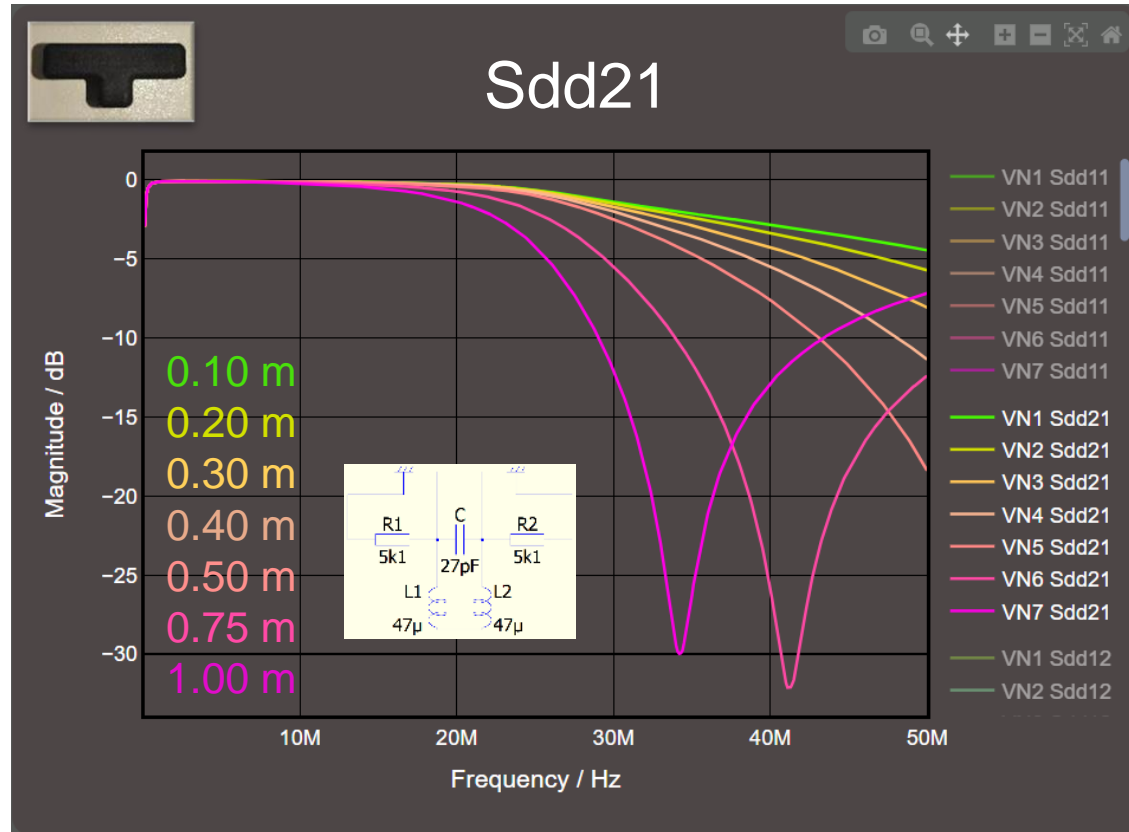

Measurement Values

Temperature Variation

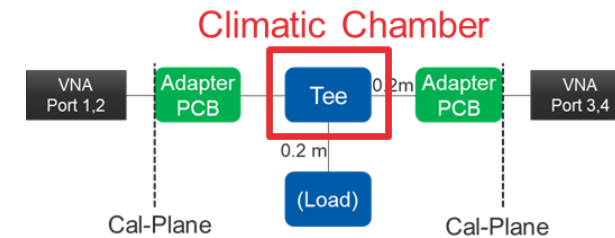
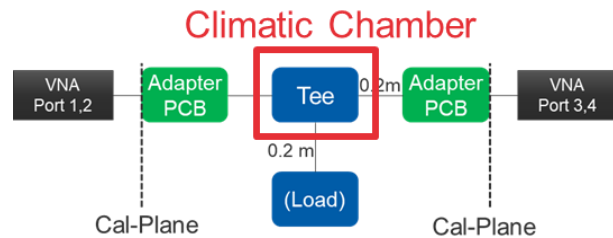
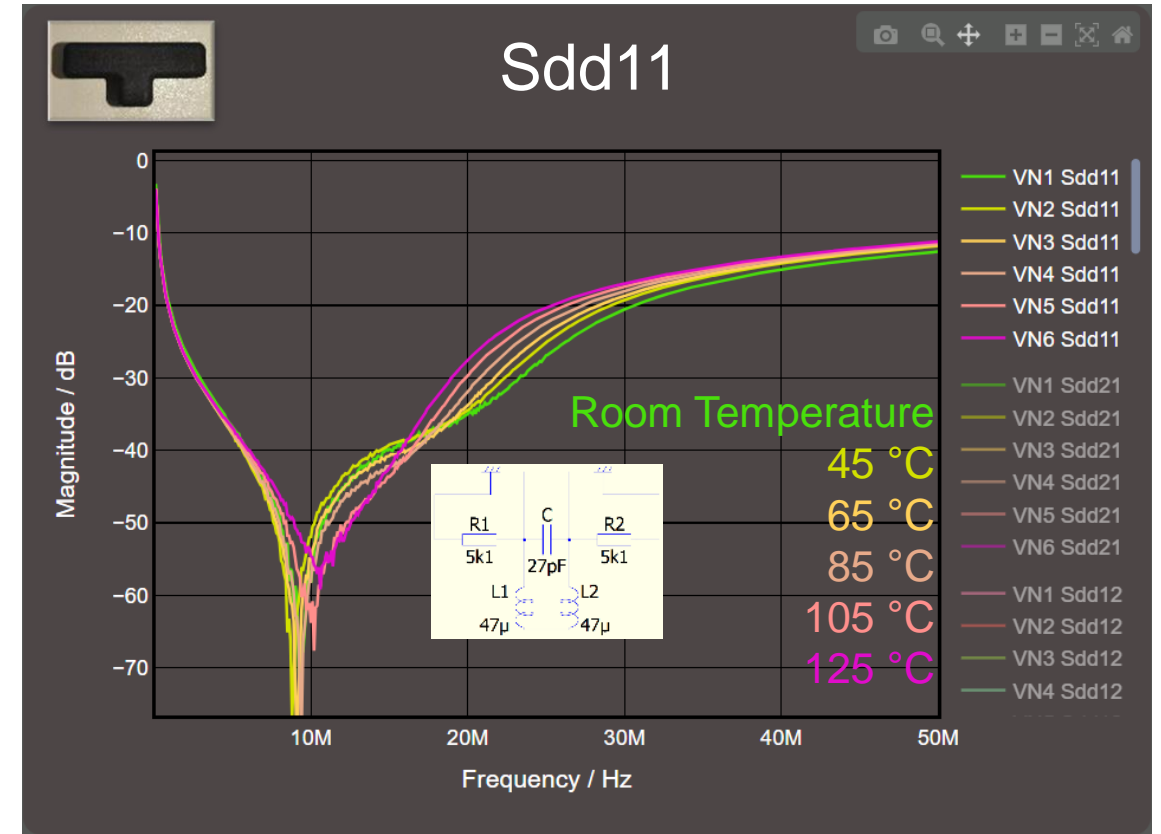
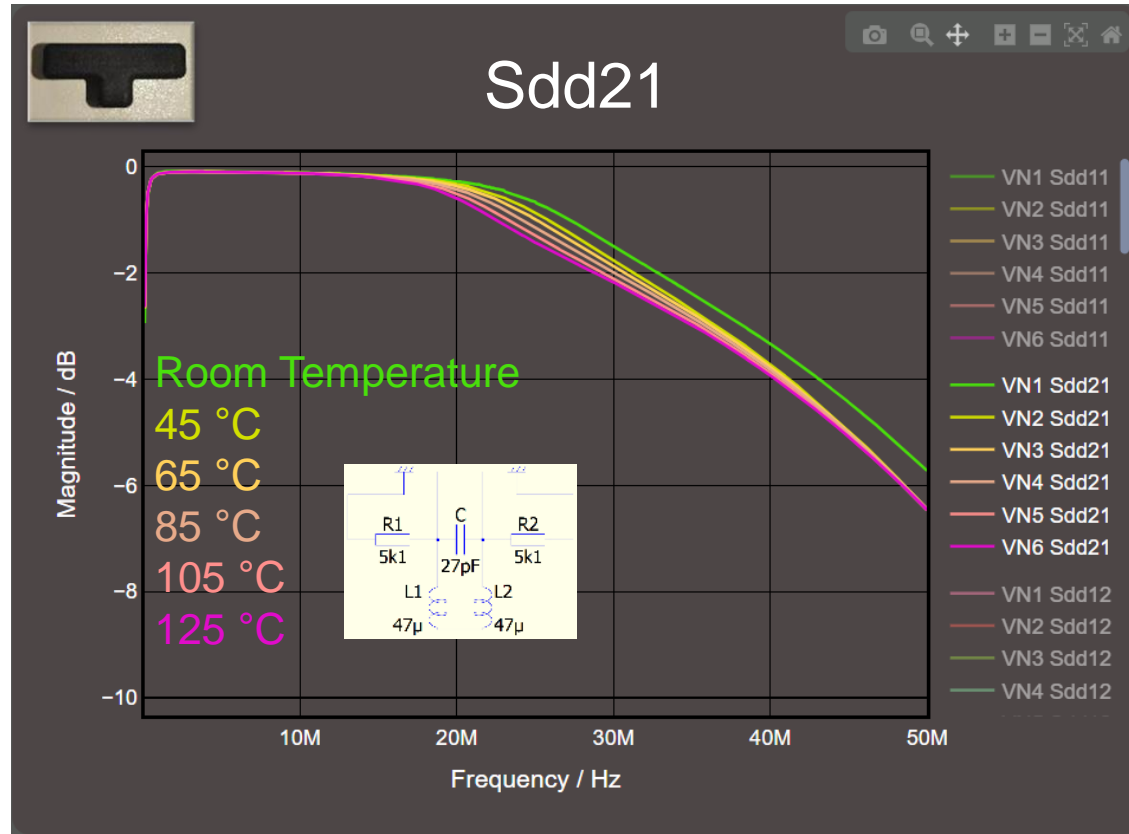

Thank you for your attention!
Questions?