

169. Multi-Drop Power over Ethernet (MPoE)

169.1 Overview

This clause defines the functional and electrical characteristics of two optional power entities, an MPoE Powered Device (MPD) and an MPoE Power Sourcing Equipment (MPSE), for use with supported single pair Ethernet Physical Layers. These entities allow devices to supply/draw power using the same cabling that is used for data transmission. MPoE is intended to provide a single pair Ethernet Physical Layer device with an interface to both the power and data.

This clause specifies the following:

- a. The characteristics of a power source to add power to the cabling system.
- b. The characteristics of a MPD's load on the power source and the cabling.
- c. A method for determining the presence of an MPD prior to applying power.
- d. A method for applying and removing power from the mixing segment in a controlled manner.
- e. A method for scaling supplied power back to the idle level when power is no longer requested or required.
- f. A method for MPDs and MPSEs to negotiate and allocate power.
- g. Power fault sensing and recovery.
- h. Requirements for adding an MPD to an already powered mixing segment.

169.1.1 Compatibility considerations

Compliant implementations of PD and PSE systems are defined as compatible at their respective Trunk Connection Interfaces (TCIs) when used in accordance with the restrictions of this clause. Designers are free to implement circuitry within the PD and PSE in an application-dependent manner provided that the respective TCI specifications are satisfied. DTEs that incorporate compliant MPoE TCIs are compatible with their respective Physical Layer standards. Such compatibility may require additional specifications found within this clause (See 169.6.2 Fault Handling).

169.1.2 Relationship of MPoE to the IEEE 802.3 architecture

MPoE is an optional power entity to be used in conjunction with supported single pair Ethernet Physical Layers. Figure 169–1 depicts the positioning of MPoE. The MPSE and MPD are positioned within separate DTEs. Compliance is specified on each pairset at the TC3 interface.

MPSEs and MPDs are compatible with 10BASE-T1M PHYs (Clause 168).

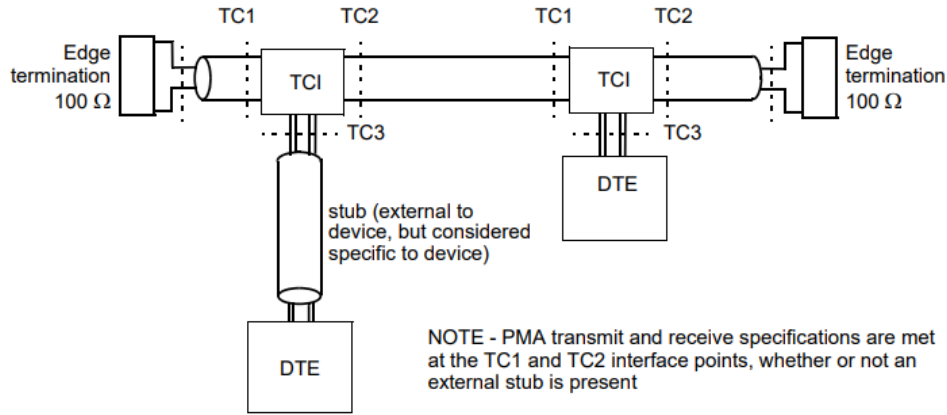

Figure 169-1—Mixing segment and reference points

169.2 Link segment

The dc loop resistance of the mixing segment shall be 15 measured from edge termination to edge termination.

169.3 System type power requirements

MPSEs and MPDs are categorized by their system type. These system types and the relevant electrical specifications are shown in Table 169-1. An MPSE may transition between Type 1 and Type 2 during IDLE (see Figure 169-2).

Table 169-1—System Power Types

	24V Nominal MPSE	50V Max MPSE
System type	0	1
$V_{MPSE(max)}$ (V) ^a	30	50
$V_{MPSE(min)}$ (V)	26	45
$I_{PI(max)}$ (mA) ^b	TBD	TBD
$P_{Type(min)}$ (W) ^c	TBD	TBD
$V_{MPD(min)}$ (V)	18	34
$P_{MPD(max)}$ (W) ^d	0.75	2

^a $V_{MPSE(max)}$ is the maximum allowed voltage provided by the MPSE at TC3 over the full range of operating conditions.

^b $I_{PI(max)}$ is the maximum current flowing at the MPSE and MPD TC3 interface except during inrush or an overload condition. $I_{PI(max)}$ may be exceeded during inrush or an overload (see TBREF). Users are cautioned to be aware of the ampacity of cabling, as installed, and local codes and regulations (see TBREF).

^c $P_{Type(min)}$ is the minimum average available output power at MPSE TC3.

^d $P_{MPD(max)}$ is the maximum average allowed power draw at MPD TC3.

169.4 Multi-drop Power Sourcing Equipment (MPSE)

The MPSE provides power to the MPD. The MPSE's main functions are as follows:

- To search the mixing segment for at least one available MPD
- To supply power to an MPD through the mixing segment
- To monitor the power applied to a mixing segment
- To apply and remove power from the mixing segment in a controlled manner

- e) To sense and recover from system faults
- f) To remove power when no longer requested or required, returning to the idle state

An MPSE is specified by its electrical and logical behavior as seen at the TC3 Interface.

169.4.1 MPSE types

An MPSE shall comply with the voltage and power requirements listed in Table 169–1 for the relevant type.

169.4.2 MPSE pin assignments

An MPSE provides power via a single two-wire connection. Table 169-2 in conjunction with **Figure 169–1** illustrates the PSE pinout. An MPSE is required to operate in a single polarity.

Table 169-2 PSE Pinout

Conductor	MPSE	PMA signal
1	Positive V_{MPSE}	BI_DA+
2	Negative V_{MPSE}	BI_DA-

169.4.3 MPSE state diagram

The MPSE shall implement the behavior of the state diagrams shown in Figures Figure 169-2 and Figure 169-3.

169.4.3.2 Conventions

The notation used in the state diagram follows the conventions of state diagrams as described in 145.2.5.2.

169.4.3.4 Variables

The MPSE state diagram uses the following variables:

mpse_enable

A variable that selects MPSE operation. This variable may be set by the MPSE at any time.

Values:

- disable: All MPSE functions disabled (behavior is as if there was no MPSE functionality).
- enable: Normal MPSE operation.

mpse_ready

Variable that is asserted in an implementation-dependent manner to mixing the link segment. This variable may be set by the MPSE at any time.

Values:

- disable: The MPSE is not ready to discover the mixing segment.
- enable: The MPSE is ready to discover the mixing segment.

mpd_type0_discovered

A variable that indicates at least one valid MPD supporting only Type 0 is connected to the mixing segment.

mpd_type1_discovered

A variable that indicates at least one valid MPD supporting only Type 1 is connected to the mixing segment.

mpd_mixed_discovered

A variable that indicates at least one valid MPD supporting both Type 1 or Type 2 is connected to the mixing segment.

discover_fault

A variable indicating if $I_{\text{Discovery}}$ measured by the MPSE during the most recent discover_high or discover_low state is equal to or greater than $I_{\text{Discovery_LIM}}$ as defined in Table 169-3. This variable is set per this description.

Values:

FALSE: Measured $I_{\text{Discovery}}$ was equal to or greater than $I_{\text{Discovery_LIM}}$ during most recent discover_high or discover_low state.

TRUE: Measured $I_{\text{Discovery}}$ was equal to or greater than $I_{\text{Discovery_LIM}}$ during most recent discover_high or discover_low state.

169.4.3.5 Timers

All timers operate in the manner described in 14.2.3.2 with the following addition: a timer is reset and stops counting upon entering a state where “stop_x_timer” is asserted.

tdiscover_high_timer

A timer used to limit the discover_high event time. See Table 169-3.

tdiscover_low_timer

A timer used to limit the discover_low event time. See Table 169-3.

169.4.3.6 Functions

The variable formed by the function name appended with “_done” is used to indicate when the function has completed. This variable is set to FALSE when the function is called and is set to TRUE once the function is complete and its output variables are valid.

do_discovery_high

This function produces the discovery mark voltage. This function returns the following variables:

discover_short: A variable indicating if I_{Mark} measured by the MPSE during do_discovery_high is greater than $I_{\text{Mark_short}}$ as defined in Table 169-3. This variable is set per this description.

Values:

FALSE: Measured I_{Mark} is less than $I_{\text{Mark_short}}$ during do_discovery_high.

TRUE: Measured I_{Mark} is equal to or greater than $I_{\text{Mark_short}}$ during do_discovery_high.

discover_high_var: Measured I_{Mark} during the most recent discover_high_mark event.

do_discovery_low_all

This function produces the discovery low voltage and measures $I_{\text{Discovery}}$. $I_{\text{Discovery}}$ is compared against I_{Mark} from the previous discover_high_mark event to determine if MPDs are present (see Table 169-3). This function returns the following variable:

mpd_discovered: This variable indicates the presence or absence of a valid MPD on the mixing segment.

Values:

open_circuit: The MPSE has detected an open circuit.

valid: The MPSE has discovered at least one MPD is connected to the mixing segment.

do_discovery_low_tare

This function produces the discovery event voltage and determines if MPDs are responding to the slot by measuring $I_{\text{Discovery}}$. This function measures the baseline $I_{\text{Discovery}}$ when PDs are receiving power from the discovery algorithm, but not issuing a discovery response. This baseline $I_{\text{Discovery}}$ will be compared against later discovery_low $I_{\text{Discovery}}$ measurements to determine which types of MPDs are connected to the mixing segment. This function returns the following variable:

discover_low_tare_var: Measured $I_{\text{Discovery}}$ during the most recent discovery_low_tare event.

do_discovery_low_evx

This function produces the discovery event voltage and determines if MPDs are responding to the slot by measuring $I_{\text{Discovery}}$. discover_low_tare_var is subtracted from the measured $I_{\text{Discovery}}$ to determine if an MPD is responding to this discovery_low event.

This function returns the following variable:

mpd_type_discovered: this variable indicates the presence or absence of a valid MPD corresponding to the discovery slot being probed.

Values

TRUE: At least one MPD responded to the most recent discovery event.

FALSE: No MPDs responded to the most recent discovery event.

169.4.3.7 State diagrams

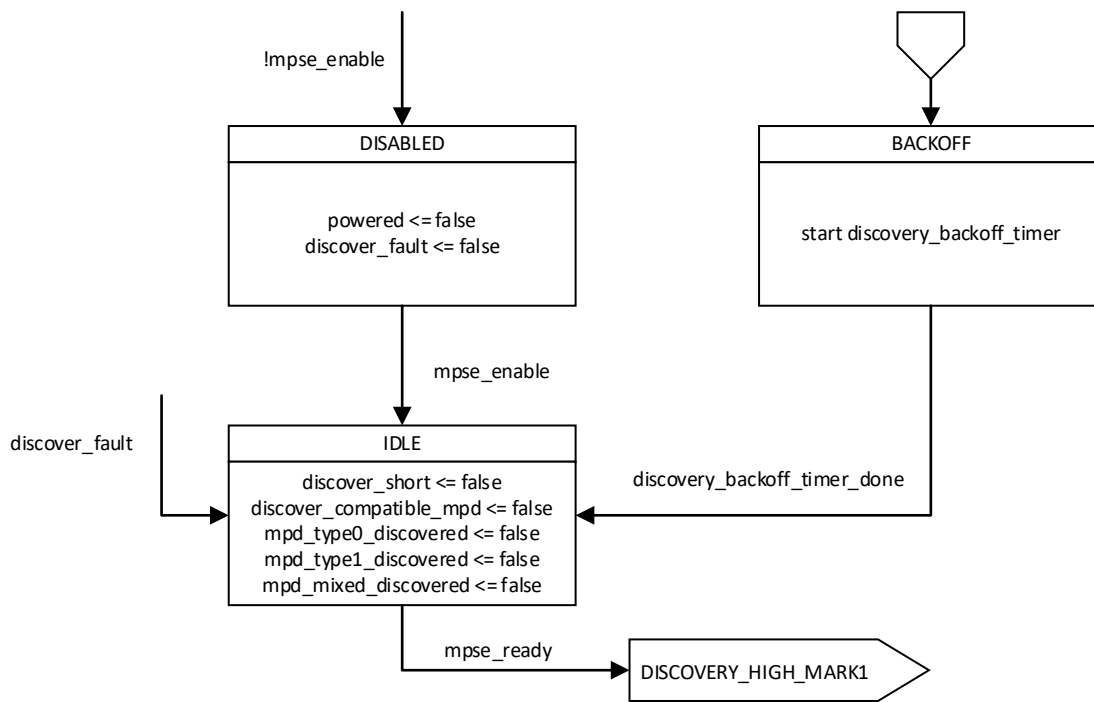

Figure 169-2- Top level PSE state diagram

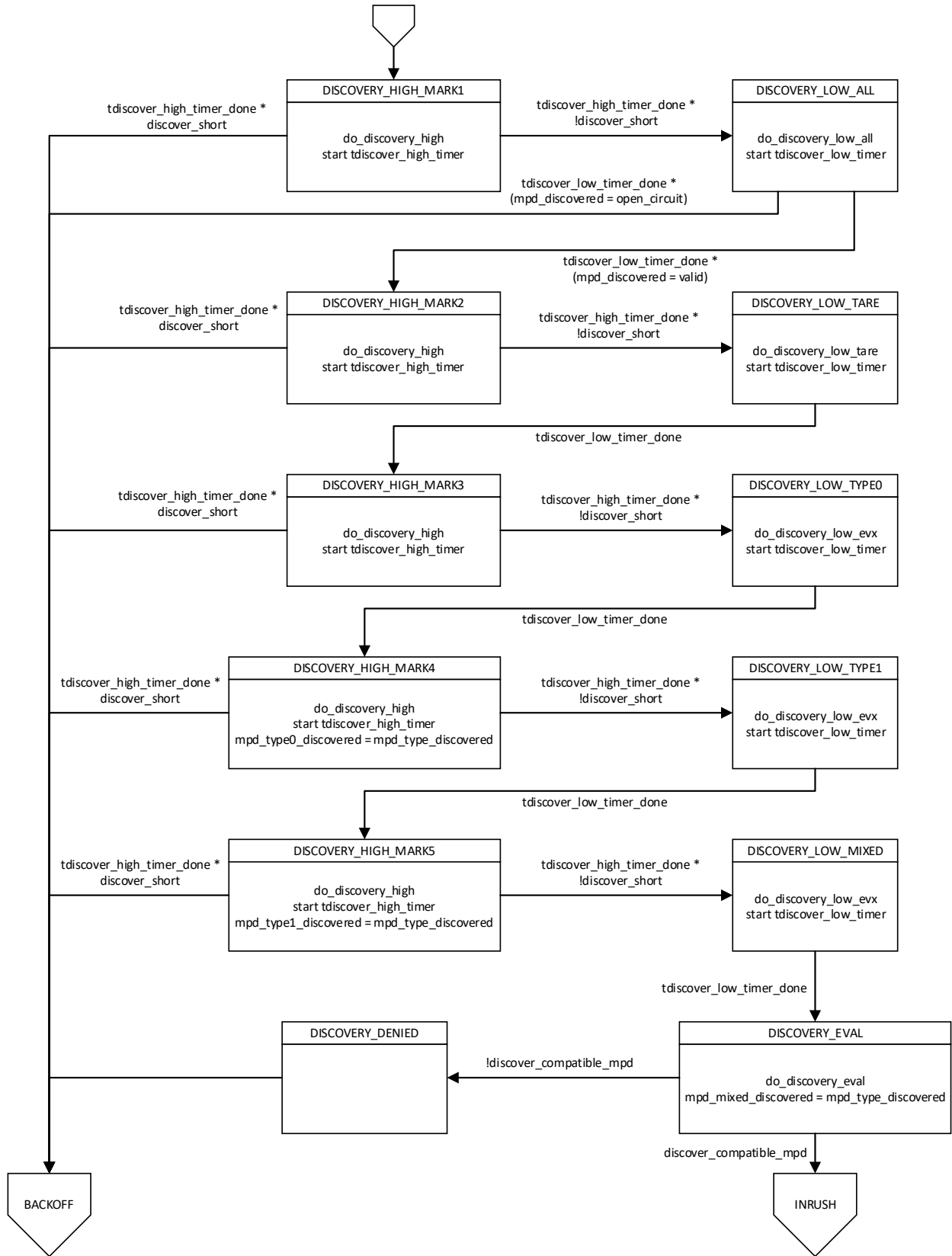

Figure 169-3- Top level PSE state diagram (continued)

169.4.4 MPSE overview

Prior to application of full operating voltage, the MPSE determines the presence of at least one valid MPD (see Table 169-3). An MPSE may apply full operating voltage if it is able to successfully discover a voltage-compatible MPD and shall not apply full operating voltage if an invalid discovery signature is measured (see Table 169-4).

After full operating voltage has been applied, the MPSE shall remove full operating voltage in response to a command from the management entity. For example, the management entity could monitor the link to determine at least one MPD remains attached, and there have been no changes in the network topology.

Additionally, while voltage is applied, the PSE monitors the current drawn and removes power if it detects an overload, short-circuit, or other fault.

169.4.5 Discovering the presence of an MPD before powering

The ability for the MPSE to query all attached MPDs to determine the assortment of system types present on the link is called discovery. Discovery also serves the function of checking that the link is clear of faults before applying power.

The MPSE shall complete discovery within $T_{Discovery}$ as specified in Table 169-3. If no valid and compatible discovery response is detected, the MPSE shall wait at least $T_{Backoff}$ before reattempting discovery. A PSE may successfully discover but then opt not to power the link.

If discovery is not completed before the $T_{Discovery}$ timer expires, the current discovery cycle shall be aborted and the MPSE shall return to BACKOFF.

Table 169-3 - MPSE Discovery Parameters

Item	Parameter	Symbol	Min	Max	Units	Additional Information
1	Discovery high mark voltage	V_{Mark}	11	13	V	
2	Discovery low voltage	$V_{Discovery}$	6	9	V	
3	Discovery current Limit	$I_{Discovery_LIM}$	30	TBD	mA	
4	Discovery high event time	$T_{Discovery_high}$	7	TBD	ms	
5	Discovery low event time	$T_{Discovery_low}$	22	TBD	ms	
6	Discovery time	$T_{Discovery}$	-	200	ms	
7	Discovery backoff time	$T_{Backoff}$	150	-	ms	
8	Mark short circuit threshold	I_{Mark_short}	3	4	mA	
9	Discovery_all MPD present range	$I_{MPD_present}$	0.8	40	mA	$I_{Discovery} - I_{Mark}$
10	MPD type present	$I_{Type_present}$	0.8	40	mA	$I_{Discovery} - I_{Tare}$

Table 169-4 - Discovery Rejection Criteria

Item	Parameter	Symbol	Min	Max	Units	Additional Information
1	Reject discovery	I_{bad}	30	-	mA	-

2	Reject discovery	I_{open}	-	200	μA	-
---	------------------	------------	---	-----	---------	---

169.4.6 MPSE output requirements

When the MPSE provides power to the MPSE PI, it shall conform to the electrical limits in Table 169-5.

Under all conditions, an MPSE shall present an invalid MPD discovery signature with one of the attributes as specified in Table 169-4.

Table 169-5 - PSE output requirements

Item	Parameter	Symbol	Unit	Min	Max	Type	Additional Information
1	DC output voltage during POWER_ON state	$V_{MPSE(PON)}$	V	26	30	0	
				45	50	1	
2	Continuous output current capability in POWER_ON state	$P_{avg}/V_{MPSE(PON)}$	A	TBD	100	0	
				TBD	100	1	
2	Output Slew Rate		dV/dt	TBD	TBD	ALL	
3	Output current – at short circuit condition	I_{LIM}	A	TBD	TBD	ALL	
4	Short-circuit time limit	T_{LIM}	ms	10	75	ALL	
5	Inrush time	T_{Inrush}	ms	10	20	ALL	
6	MPD Maintain power signature dropout time limit	T_{MPSDO}	ms	TBD	TBD	ALL	
7	PD MPS time for validity	T_{MPS}	ms	6	-	ALL	
8	DC MPS current	I_{HOLD}	mA	4	9	ALL	
9	Error delay timing	T_{ED}	ms	750	-	ALL	
10	Overload current	I_{CUT}	mA	TBD	TBD	ALL	
11	Overload time limit	T_{CUT}	ms	50	70	ALL	

169.4.7 Continuous output power in POWER_ON state

TBD is the minimum continuous power that the MPSE shall be capable of supplying as defined in Table 169-5.

169.4.8 Overload current

If the current exceeds ICUT for longer than TCUT, the MPSE may remove power. The cumulative duration of TCUT is measured using a sliding window of at least TBD second width.

169.4.9 MPSE power removal

While the MPSE is operating in POWER_ON, full operating voltage shall be removed from the TCI in the absence of the PD MPS, if overload_detected is TRUE, or if commanded to do so by a management entity.

169.4.9.1 MPSE maintain power signature (MPS)

MPS shall be defined as being present in the POWER_ON state when I_{MPSE} is greater than or equal to $I_{Hold\ max}$ for a minimum of T_{MPS} . MPS may be defined as present or absent in the POWER_ON state if I_{PSE} is in the range of I_{Hold} . MPS shall be defined as absent in the POWER_ON state if I_{MPSE} is less than or equal to $I_{Hold\ min}$. Power shall be removed from TC3 when MPS has been absent for a duration greater than $T_{MP\ SDO}$.

The MPSE shall not remove power from the port when I_{MPD} is greater than or equal to $I_{Hold\ max}$ continuously for at least T_{MPS} every $T_{MPS} + T_{MP\ DO}$, as defined in Table 169-5. This allows an MPD to minimize its power consumption.

169.5 Multidrop Powered Device (MPD)

An MPD is the portion of a device that is either drawing power or requesting power by participating in the MPD discovery algorithms. A device that is capable of becoming an MPD may have the ability to draw power from an alternate power source. An MPD requiring power from the TCI may simultaneously draw power from an alternate power source.

An MPD is specified at the point of physical connection to the trunk. Limits defined for an MPD are specified on both pairsets of the TC3 interface.

169.5.1 PD system types

PDs can be characterized as Type 0, Type 1, or Type Mixed.

Type 0 MPDs receive power from Type 0 MPSEs only. Type 1 MPDs receive power from Type 1 MPSEs only. Type Mixed MPDs receive power from either Type 0 MPSEs or Type 1 MPSEs.

169.5.2 PD PI

An MPD may receive power in two modes, Mode A and Mode B. MPDs are insensitive to the polarity of the power supply and shall be able to operate per the Mode A column and the Mode B column in Table 169-6.

Table 169-6 - MPD pinout

Conductor	Mode A	Mode B
1	Positive V_{MPD}	Negative V_{MPD}
2	Negative V_{MPD}	Positive V_{MPD}

Author's Note (MP 6/28/23): Without a defined connector in the system the probability of miswiring the MPDs is very high. Polarity rectification therefore should be a requirement to assure that networks will work when 16-32 nodes with random wiring swaps are connected.

169.5.3 PD State Diagram

The MPD shall implement the behavior of the state diagrams shown in Figures Figure 169-4 and Figure 169-5.

169.5.3.2 Conventions

The notation used in the state diagram follows the conventions of state diagrams as described in 145.2.5.2.

169.5.3.2 Constants

$I_{Inrush_MPD_max}$

The maximum MPD inrush current $I_{Inrush_MPD\ max}$ (see Table TBREF).

$V_{Reset_MPD_max}$

The maximum MPD reset voltage $V_{Reset_MPD\ max}$ (see Table TBREF).

169.5.3.3 Variables

The MPD state diagram uses the following variables:

mpd_type

A variable indicating the MPD type.

Values:

0: The MPD supports only Type 0.

1: The MPD supports only Type 1.

mixed: The MPD supports both Type 0 and Type 1.

mpd_reset

An implementation-specific variable that unconditionally resets the MPD state diagram to OFFLINE. This variable may be set by the MPD at any time.

Values:

FALSE: The device has not been reset.

TRUE: The device has been reset.

dte_power_required

A variable indicating that the MPD is enabled and should request power from the MPSE by participating in the discovery protocol, and when the MPSE sources power to apply the MPS to keep the MPSE sourcing power. This variable may be set by the MPD at any time.

Values:

FALSE: MPD functionality is disabled.

TRUE: MPD functionality is enabled.

present_mark_sig
Controls presenting the mark event current (see TBREF) by the MPD.
Values:
FALSE: The MPD does not present mark event behavior.
TRUE: The MPD does present mark event behavior.

present_discovery_sig
Controls presenting the discovery event current (see TBREF) by the MPD.
Values:
FALSE: The MPD does not present discovery event behavior.
TRUE: The MPD does present discovery event behavior.

present_mps
Controls applying the Maintain Power Signature MPS (see TBREF) to TC3.
Values:
FALSE: The MPS is not to be applied to TC3.
TRUE: The MPS is to be applied to TC3.

present_tci_power
Values:
FALSE: The MPD is disabled or not ready to consume full power from TC3
TRUE: The MPD is enabled and ready to consume full power from TC3

$V_{\text{Mark_th}}$
Mark event voltage threshold (see Table TBREF).

$V_{\text{Off_MPD}}$
MPD power supply turn off voltage (see Table TBREF).

$V_{\text{On_MPD}}$
MPD power supply turn on voltage (see Table TBREF).

V_{MPD}
Voltage at the MPD TC (see Table TBREF).

$V_{\text{Reset_th}}$
Reset voltage threshold (see Table TBREF).

$V_{\text{type0_th}}$
Threshold between discovery and type 0 operating region.

$V_{\text{type1_th}}$
Threshold between Type 0 operating region and Type 1 operating region.

169.5.3.4 Timers

All timers operate in the manner described in 14.2.3.2 with the following addition: a timer is reset and stops counting upon entering a state where “stop_x_timer” is asserted.

pon_holdoff_timer
A timer used to hold off the inrush of an MPD after V_{mpd} crosses the $V_{\text{type0_th}}$ threshold.

169.5.3.5 Functions

TBD

169.5.3.6 State Diagram

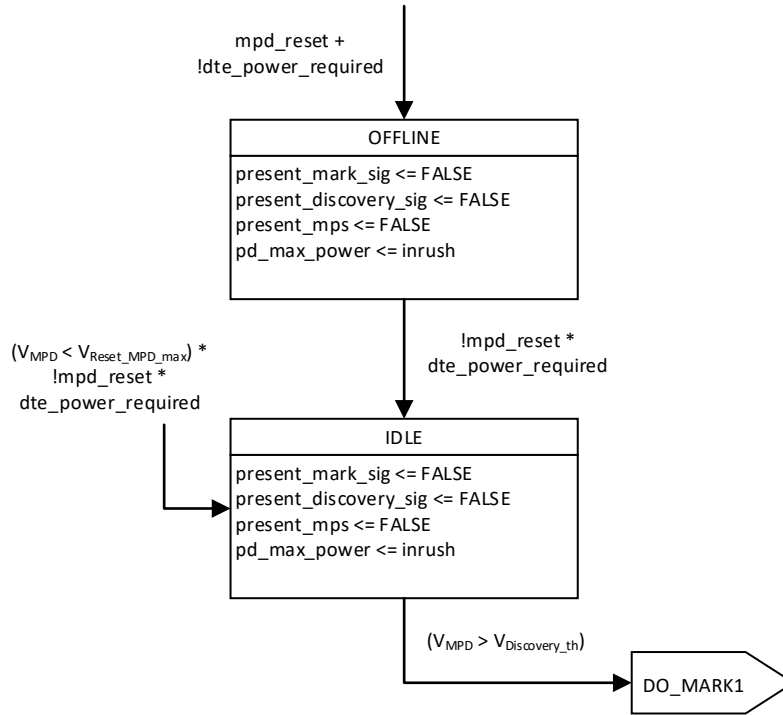

Figure 169-4 - Top level PD state diagram

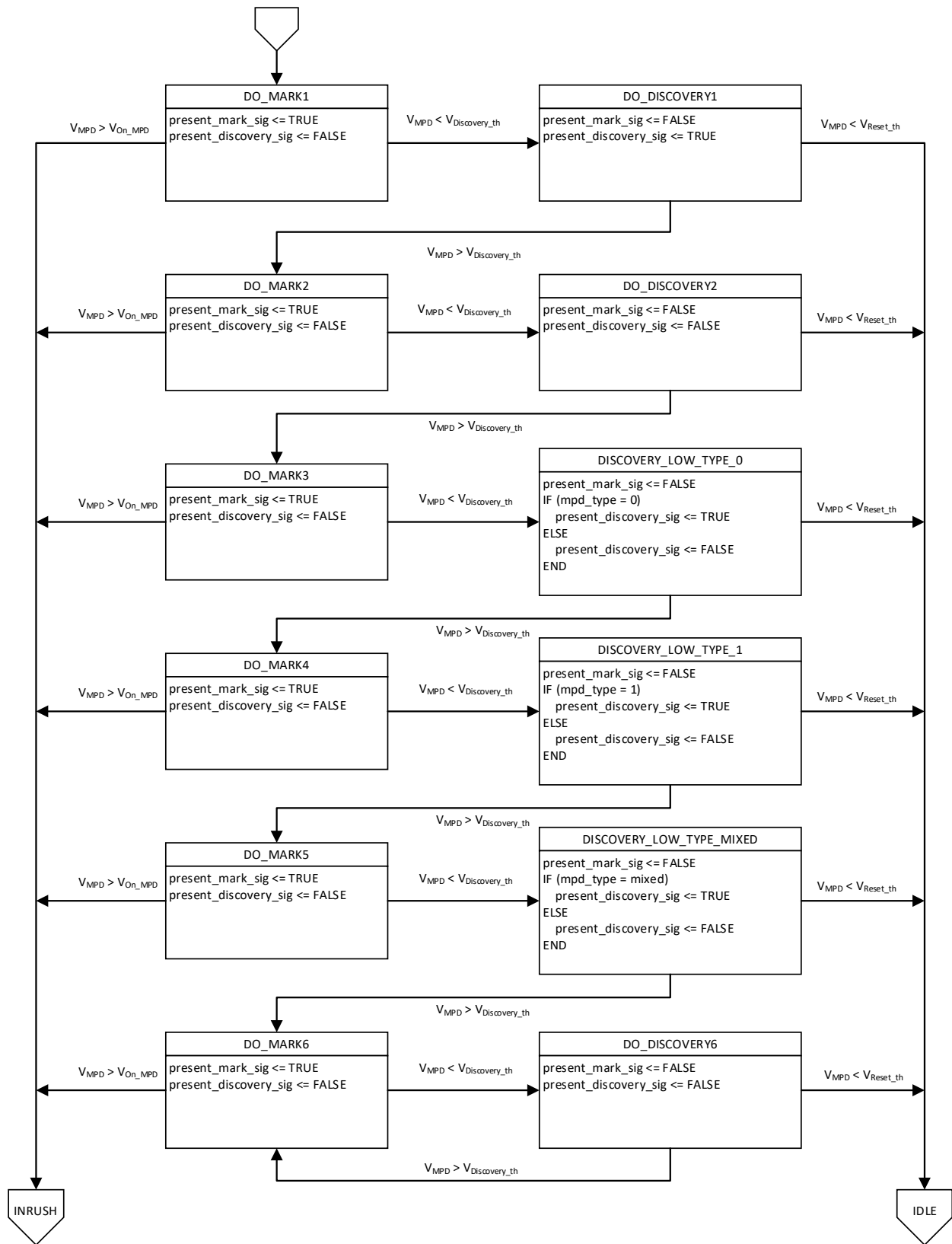

Figure 169-5 - Top level PD state diagram (continued)

169.5.5 MPD Discovery

TBD

169.5.6 MPD Power

The power supply of the MPD shall operate within the characteristics in Table 169-7.

The MPD may be capable of drawing power from a local power source. When a local power source is provided, the MPD may draw some, none, or all of its power from TC3.

Table 169-7 - MPD Power Supply Limits

Item	Parameter	Symbol	Unit	Min	Max	Type	Additional Information
1	Input Voltage	V_{Port_MPD}	V	18	30	0	
				34	50	1	
2	Input m power	P_{MPD}	W		0.75	0	
					2	1	
3	Inrush Current	I_{Inrush_MPD}	A	-	10mA	All	
4	MPD Type 0 Voltage threshold	V_{TYPE0_TH}	V	14	18	ALL	
5	MPD Type 1 Voltage Threshold	V_{TYPE1_TH}	V	30.1	24	ALL	
6	Inrush Backoff Time	$T_{Inrush_backoff}$	ms	10ms	TBD	All	
7	Inrush to operating state delay	T_{Delay}	ms	TBD	TBD	All	
8	MPD TC3 capacitance during POWER_ON	C_{Port}	uF	-	TBD	All	
9	MPD Current when connected to incompatible PSE type	$I_{MPD_DISABLED}$	uA	-	500	All	

169.5.7.1 MPD Inrush

TBD An MPD shall not draw application level power from TC3 when it is connected to an incompatible system type. To determine whether the MPD is connected to a compatible MPSE type, the MPD shall not draw full operating power until V_{mpd} crosses V_{type0_th} and $T_{inrush_backoff}$ time has elapsed. After

$T_{\text{inrush_backoff}}$ time has elapsed, if the TC3 voltage is in a range that is compatible with the MPD type, the MPD may begin drawing full operating power corresponding with the MPD system type.

If V_{mpd} is greater than $V_{\text{type0_th}}$, the $T_{\text{inrush_backoff}}$ time has elapsed, and V_{mpd} is not in a voltage range that is compatible with the MPD type, the MPD shall draw less than $I_{\text{MPD_DISABLED}}$ current and provide an active indication to the user that the MPD is connected to an incompatible MPSE.

6 Additional Electrical Specifications

6.1 Isolation

6.2 Fault Tolerance

MPDs tolerate 60V in either polarity (see 168.8.2).

MPSEs tolerate 60V applied with specified polarity in 169.4.2. MPSEs tolerate I_{LIM} for T_{LIM} when connected to the mixing segment in reverse polarity and the power source is another MPSE.

7 Environmental

TBD

8 PICS

TBD