

This state machine sets a count down timer to 1 second, sets a PDU counter to 10, and waits for the timer to expire. Figure 57-5 is modified to decrement the counter each time a PDU is sent within the 1-second window. If the timer expires without any decrement of the counter during that 1-second window, a PDU is sent.

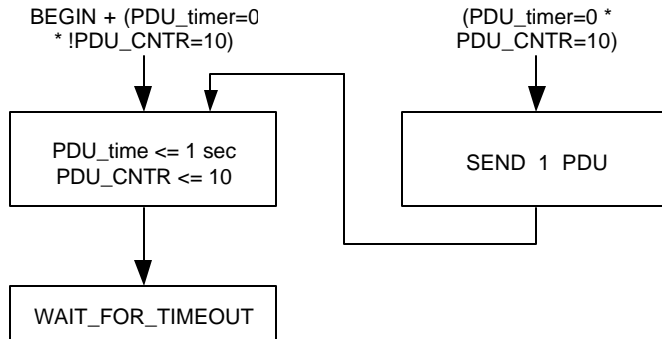
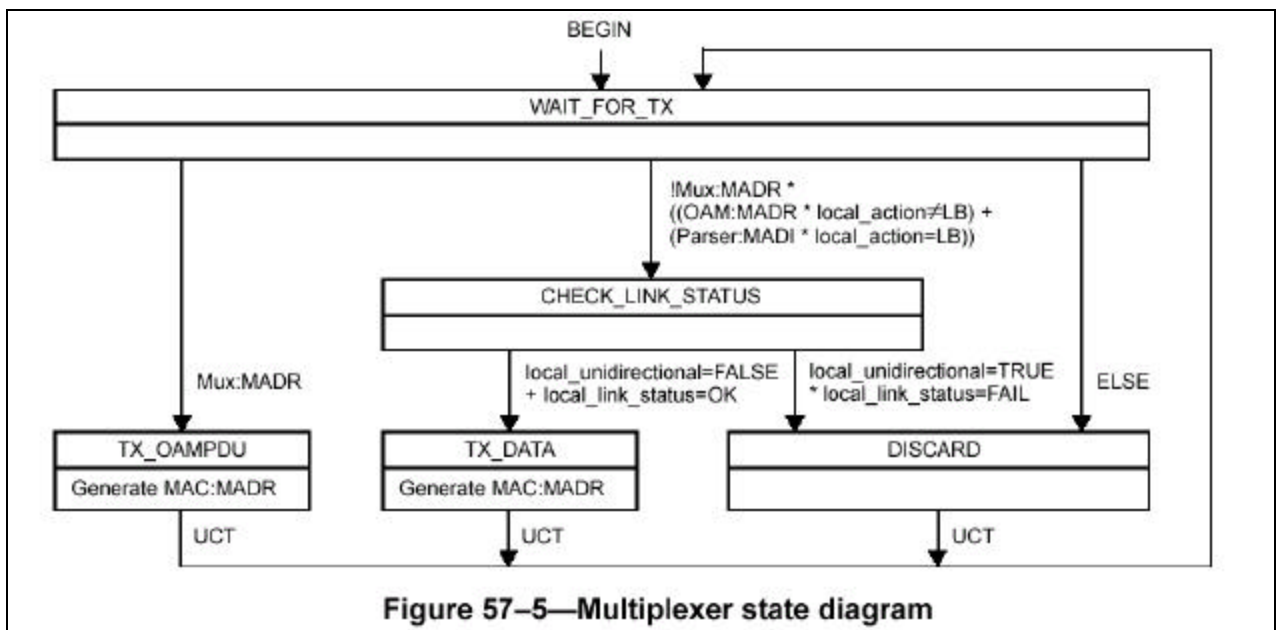

Figure 57-5 is also modified to disallow PDU transmission when the PDU counter reaches zero. This affects the gates into the TX_OAMPDU and CHECK_LINK_STATUS states.

57-5 changes:



Change TX_OAMPDU gate to: Mux:MADR * !PDU_CNT=0

Change TX_OAMPDU action to: Generate MAC:MADR, PDU_CNT <= PDU_CNT-1

Change CHECK_LINK_STATUS gate to: (!Mux:MADR + PDU_CNT=0) * ((OAM:MADR...

Though not included here, it should be obvious that this can be readily modified to support a greater number of OAM PDUs during a 1-second window when the link is operating unidirectionally, etc.

