

P2MP Burst Mode Transceiver and guard band

Ajay Gummalla, Broadcom

JC Kuo , Alloptic

Supporters:

Lior Khermosh, Passave

Larry Rennie, National Semiconductor

Contents

- Burst mode transmitter (ONU)
- Burst mode receiver (OLT)
- System guard band margin analysis
- Bandwidth efficiency considerations
- Summary

Burst mode transmitter (ONU)

- Transmitter activation delay
 - Electric delay
 - APC close loop stabilized delay
- Transmitter deactivation delay
- Leakage power at deactivated mode

Burst mode receiver (OLT)

- Receiver capture time considerations
 - $\pm 15\text{dB}$ optical step change between two transmissions
 - 8b/10b line coding result 125MHz minimum frequency
 - DC canceling loop time constant in TIA
 - AGC loop time constant in TIA
- Clock and data recovery time (1.25Gb/s)
 - 8b/10b line coding
 - FEC is used, assume 4dB gain (-4dB optical signal at PIN/TIA input, results higher jitter and pulse width distortion to clock and data recovery input)

Asynchronous burst mode receiver

OLT Async Receiver

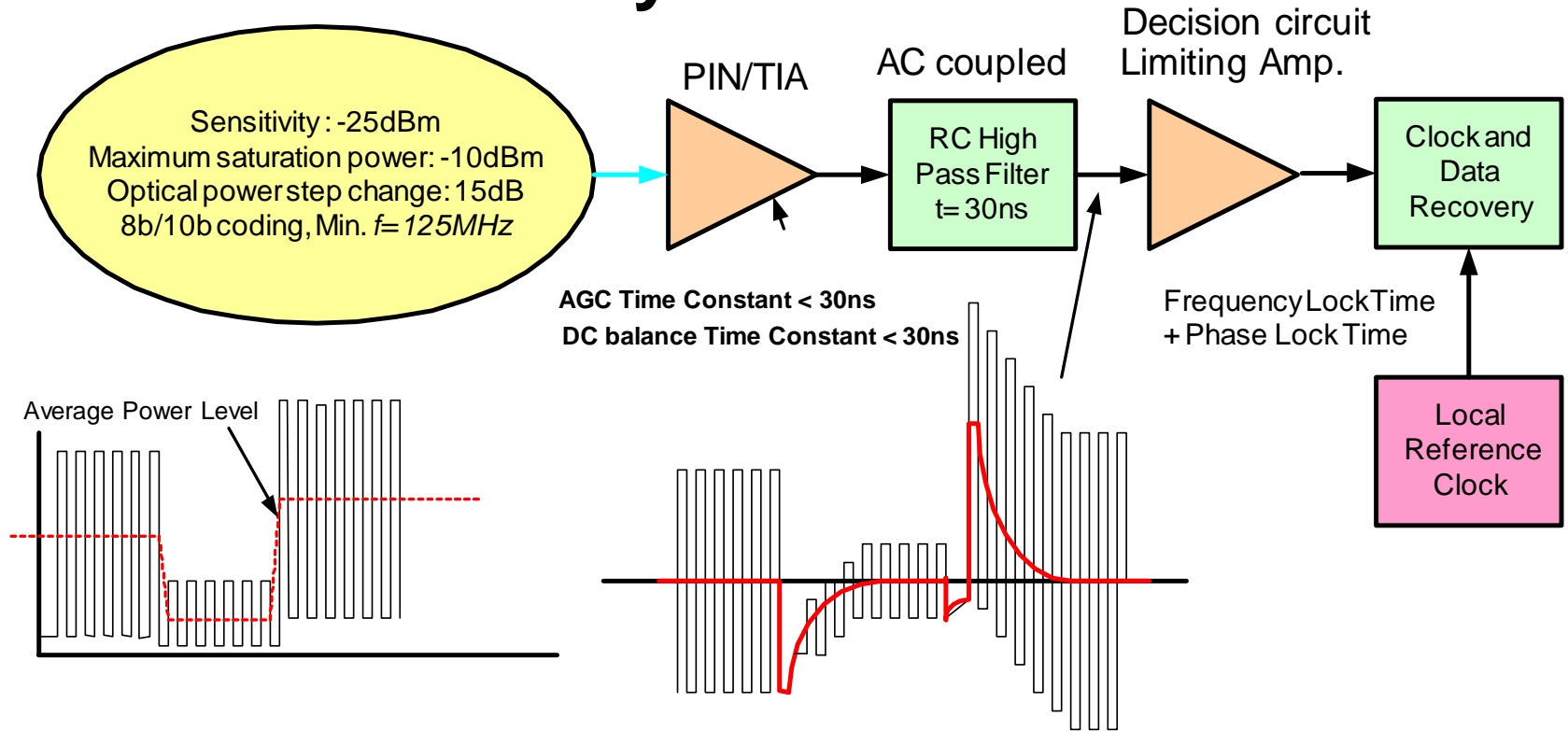

Asynchronous BMR

■ Advantage

- No synchronization is required, self tracking
- Technical feasible
- Low cost

■ Disadvantage

- Slow acquisition time
- AC coupled, acquisition time is line coding dependent

■ Performance improvement

- Frequency lock ONU transmission clock to OLT will eliminate frequency lock time
- The cutoff of the high pass filter effects the spectrum of the signal coming in. Its effect on receiver sensitivity needs to be carefully studied

Synchronous burst mode receiver

OLT Sync Receiver

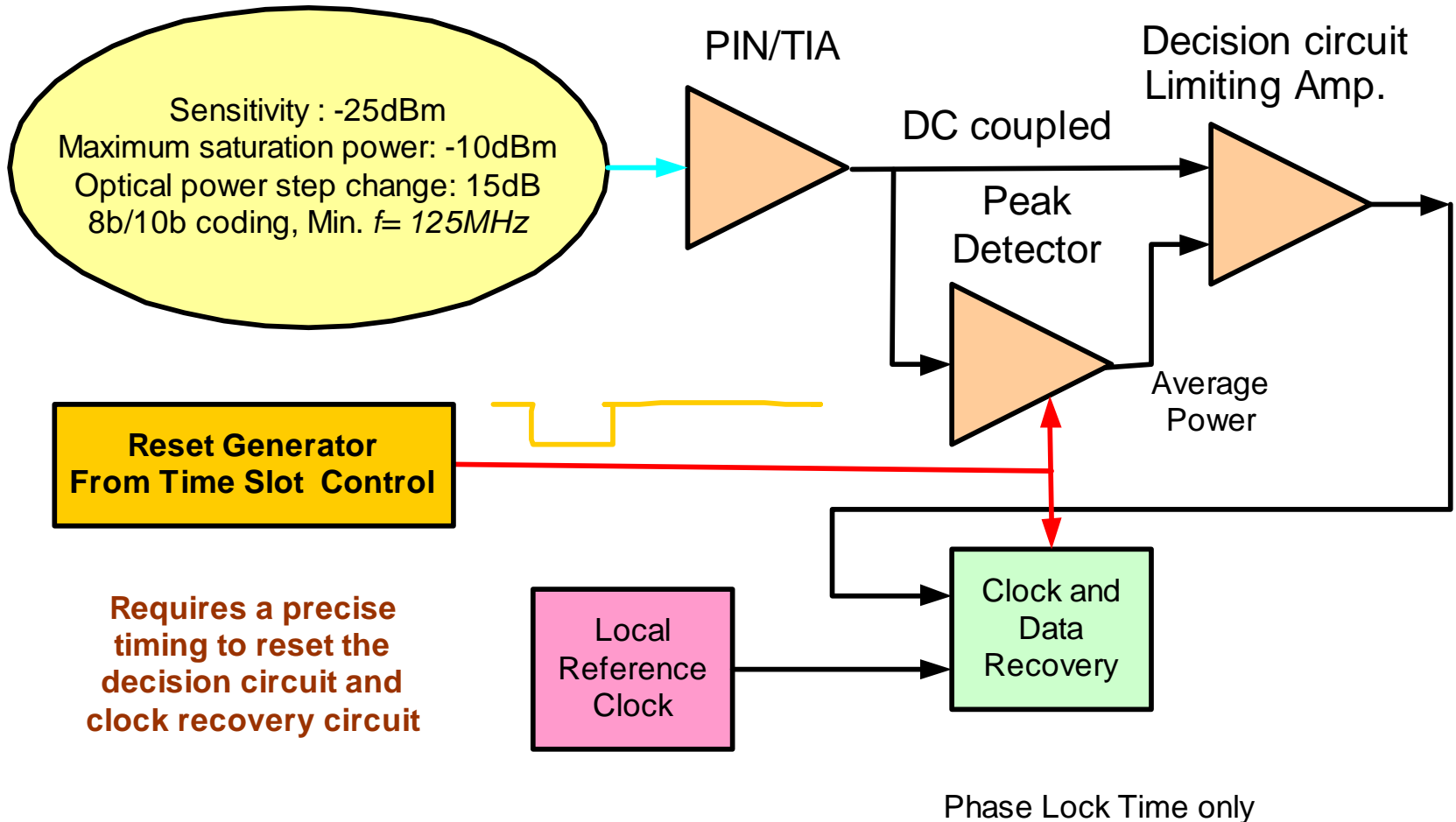

Synchronous BMR

■ Advantage

- Fast acquisition time, not line coding dependent
- More efficient system

■ Disadvantage

- Questionable technical feasibility at 1.25Gb/s
- Need precise reset signal (must use PHY with high resolution system clock to control timing)
- Synchronization complexity
- Need special coded delimiter for restoring the receiver decision level

System Guard Band margin

- System guard band – The dead zone between two ONU transmissions
- Three margins
 - Electric control margin
 - Optical delay margin
 - Time sharing protocol margin

Electric control margin

- ONU transmitter activated/deactivated delay time
- OLT receiver capture time
- OLT receiver clock recovery time
- Resolution of system clock (phase variation of OLT and ONU system clocks)
 - High resolution system clock cost more on silicon
 - Example of 125MHz system clock has margin of ± 8 bit or ± 8 ns

Optical delay variation margin

- Optical round trip considerations
 - 20km optical round trip delay is about 200uS
 - At 1.25Gb/s, one bit length is about 15cm (6")
 - Fiber cable length change cause by environmental – Wind, ice, temperature and animal
 - $\pm 0.1\%$ of 20km fiber = 400ns optical delay variation
 - Optical Path length change = 8ppm/C
 - Max diurnal delay = $50C \times 1E5ns \times 8E-6 = 40ns$
- Margin for optical delay is protocol dependent
 - Optical delay change within fine ranging loop time
 - Optical delay change between two worst case transmission opportunities if flexible bandwidth assignment is used

Time sharing protocol margin

- Unpredictable transmission stop/start position
 - Delay variation cause by random transmission with variable packet size in MAC control layer based time sharing control

Bandwidth efficiency consideration

- Guard band
 - Electric control delay margin is a fixed constant
 - Need analysis on clock and data recovery performance of FEC
 - Optical delay variation margin can be improved by high fine ranging frequency but it take more downstream bandwidth
 - Time sharing protocol margin can be eliminated by guaranteed start/stop transmission position
- No packet fragmentation
 - Maximum Ethernet frame is 12us
 - Average unused gap is 1.5us (assumed 400 byte average packet length)

Summary

- Careful study of the cost vs performance tradeoff is necessary in the choice of burst transceiver
 - Frequency synchronization takes the longest time
 - Study effect of AC coupling on receiver sensitivity
 - Fully synchronous receiver requires accurate state of arrival of upstream bursts
- Have to account for three uncertainties in guard band allocation
 - Electrical
 - Optical
 - Protocol