

EPoC Performance Model Delay and Efficiency

Andrea Garavaglia – Qualcomm

Ed Boyd – Broadcom

Rick Li – Cortina

Bill Powell – Alcatel-Lucent

Hesham ElBakoury – Huawei

Disclaimer

- The EPoC performance model aim at providing a tool (spreadsheet) to play with tradeoff between delay and efficiency of EPoC systems
- Input values are parameterized so that different solutions/option could be considered when evaluating delay and efficiency of certain proposal
- The focus of the EPoC performance model is primarily on the coax PHY and also includes additional impact due to MPCP/MAC layer
- ...

To be further refined

MAC Performance Model - Summary

- Focus on delay but also consider efficiency
 - For both delay and efficiency, two components: PHY and MAC
 - Look at worst case in supported multi-user scenarios
 - Is 1 Gb/s PAR objective to individual CNU or on coax segment? → **Q5**
 - Efficiency: need to know how much efficiency is consumed by overhead due e.g. guard interval, guard bands, etc. – focus on relative figures and efficiency on the coax side – how the trade-off affects delay vs. efficiency
- Improve the model with further details
 - Consider symbol duration
 - Consider preamble presence/duration
 - Split propagation time (cable length) from switching time
 - Transmit/receive sharing PHY and influence on the switching time
 - Number of simultaneous transmitters
- Important question is: does the absolute numbers meet the delay/jitter requirements?

Delay Model – Latency and Jitter

- The delay model is meant to firstly characterize latency and jitter of the coax portion of the plants, with focus on the PHY and considering as reference points the interfaces between MAC and PHY (see figure)
- Optical part could be considered as well, OCU can be modeled with simple configurable delay (see next slide)

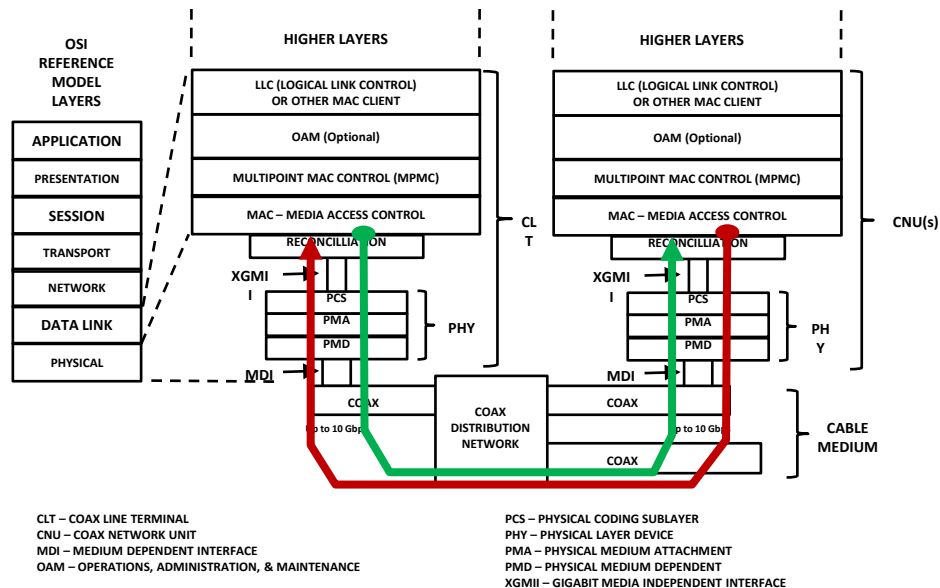

- In addition, implications at MAC layer are considered, whereby the overall delay and jitter are generally represented as a function of PHY and MAC:

$$\text{delay} = \text{function}(\text{PHY}, \text{MAC}) \quad \text{and} \quad \text{jitter} = \text{function}(\text{PHY}, \text{MAC})$$

- The PHY components consider the delay due to processing at the transmitter and receiver sides (e.g. symbol processing, interleavers, etc.), possible guard intervals and preambles, the number of transmitters and min/max burst sizes
 - Propagation delay is treated separately and linked to the cable length
- The MPCP/MAC components considers the additional delay due to the resource allocation and depends primarily on scheduling/ polling cycles, the number of transmitters and min/max burst sizes, report cycle

Delay Model – Reference Scenarios

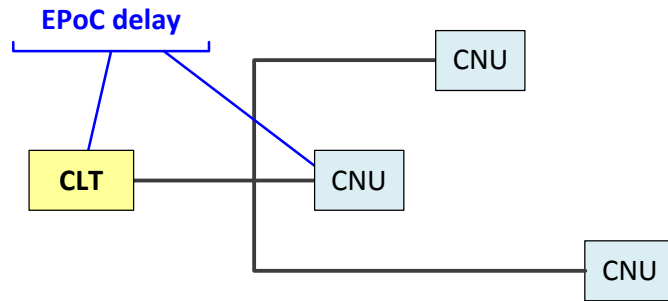

(a)

The EPoC performance model is focus on the **EPoC part**, for which a detailed model will be developed to characterize delay and efficiency tradeoffs.

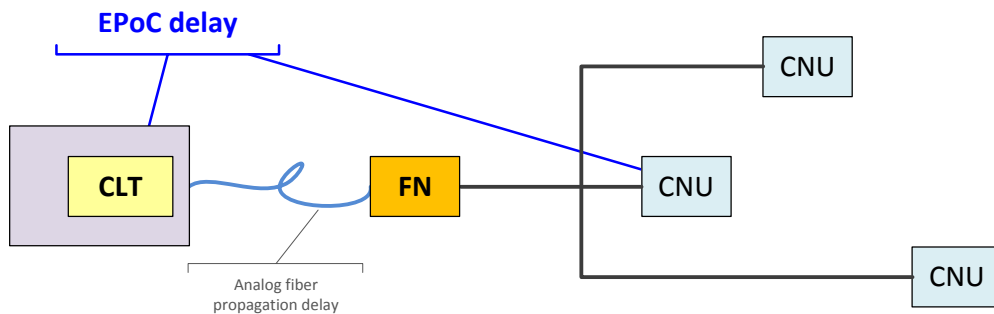

(b)

The case of EPoC deployed with analog fiber and CLT in headend can be easily considered adding analog fiber delay as function of the optical fiber length.

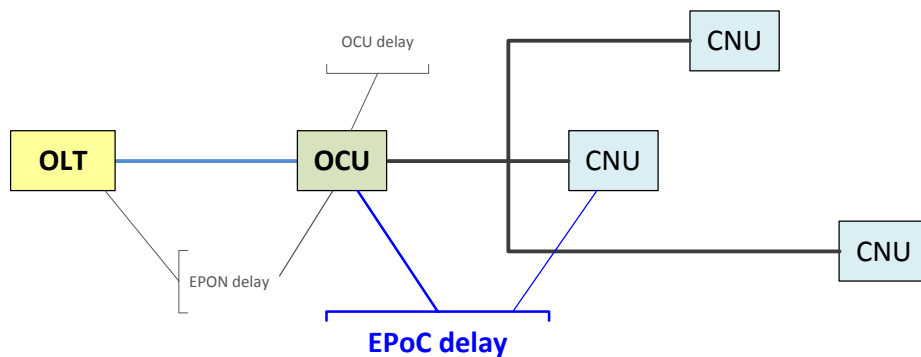

(c)

Similarly, the case of EPON with digital fiber can be easily considered adding EPON delay and OCU delay terms.

Shall be kept or removed?

Note: no detailed model for EPON or HFC will be developed

Delay Model – PHY for FDD downstream

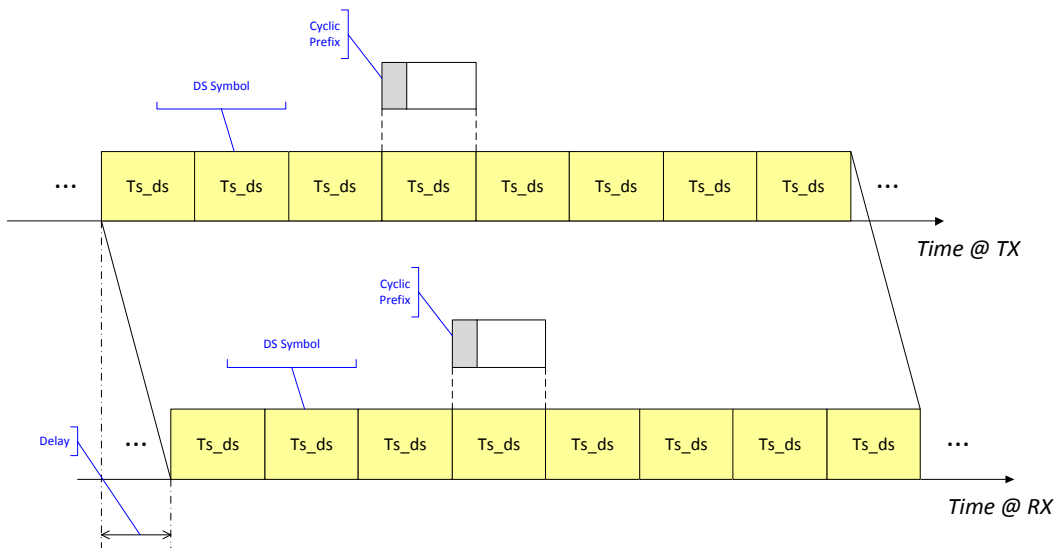

In case of FDD downstream there is a continuous transmission consisting in a sequence of DS symbols

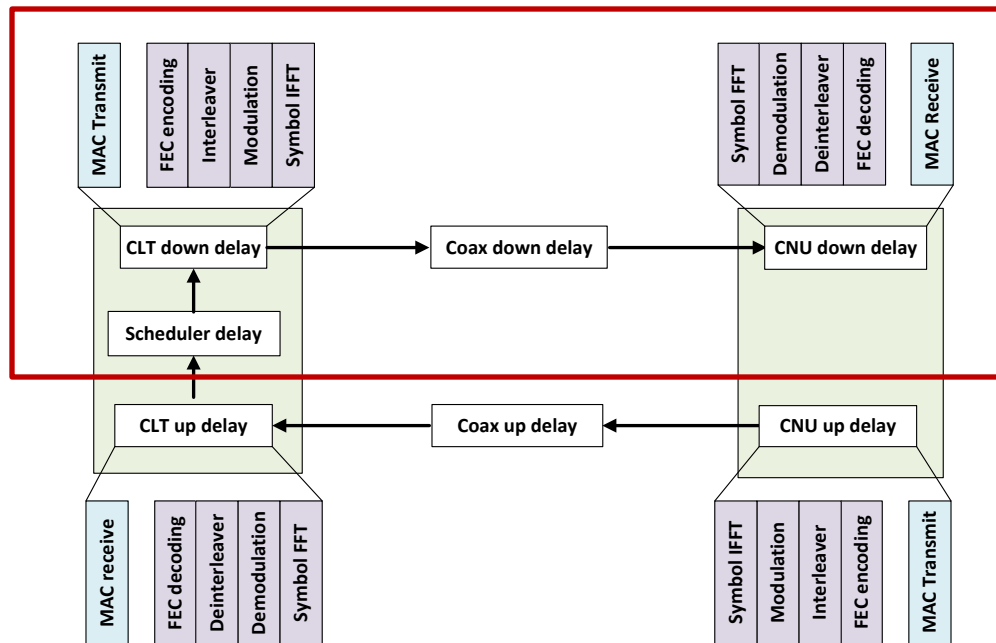

Generally speaking the PHY needs to perform operations for:

- FEC encoding/decoding
- Interleaving/de-interleaving
- Modulation/demodulation
- Symbol IFFT/FFT

Some of the operations are block-level processing related to symbol duration – some may not be present

See next slide for details

Delay Model – PHY for FDD downstream (cont.)

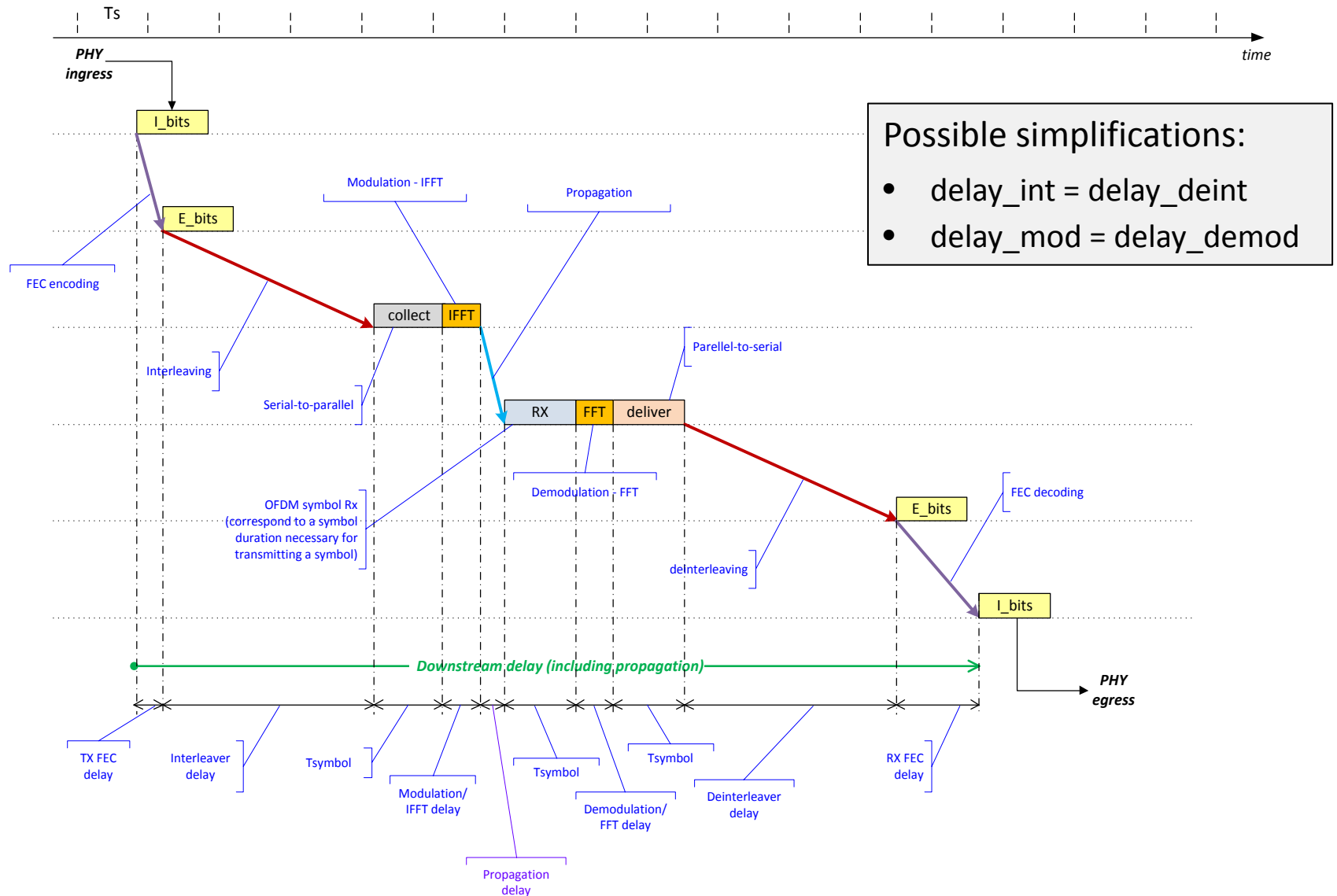

Note: Propagation delay depends on the cable plant and can vary significantly – this is just an example.

Delay Model – PHY for FDD upstream

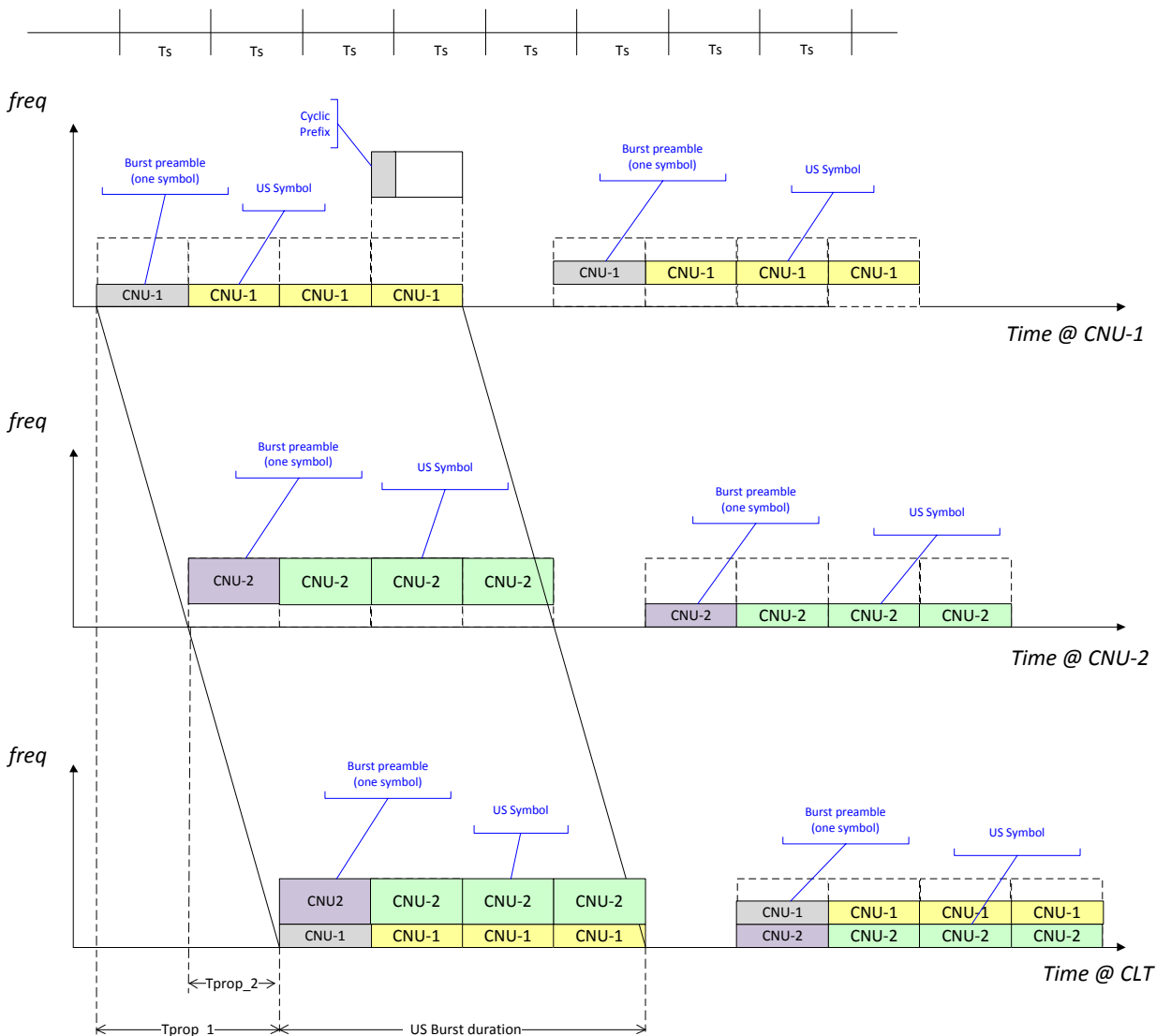

In case of FDD upstream there is a burst transmission consisting in a sequence of upstream symbols

- The transmit sequence could include a burst preamble (of $N \times$ symbol duration)
- Different CNU are time-aligned via RTT compensation
- Concurrent transmission could be enabled in the frequency domain

Note: the burst preamble at the start of each US transmission could be included to help with clock alignment in US and with channel estimate, depending on the particular solution whether needed or not.

Delay Model – PHY for FDD upstream (cont.)

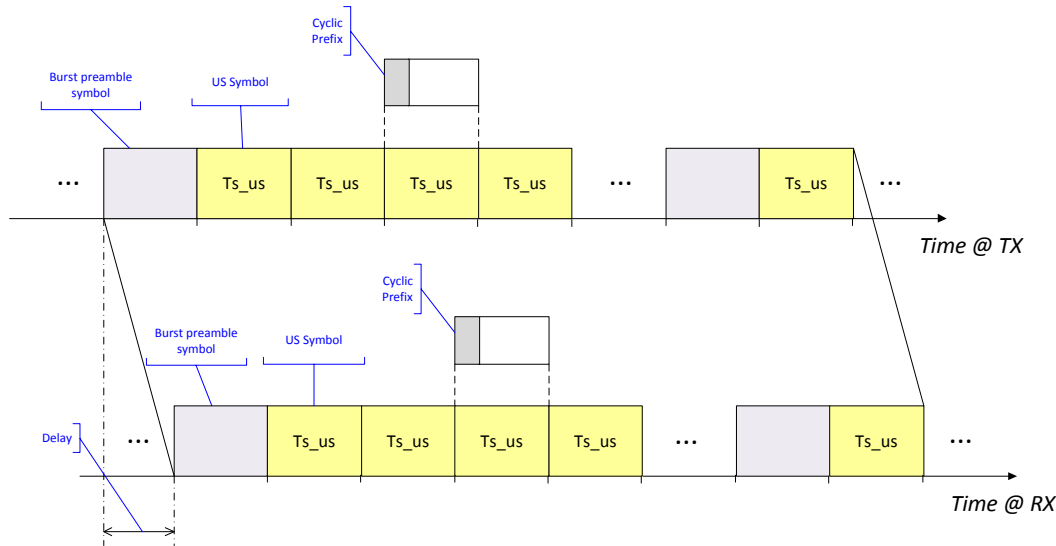

In case of FDD upstream there is a burst transmission consisting in a sequence of US symbols and potentially starting with a burst preamble (of $N \times \text{symbol duration}$)

Generally speaking the PHY needs to perform operations for:

- FEC encoding/decoding
- Interleaving/de-interleaving
- Modulation/demodulation
- Symbol IFFT/FFT

Some of the operations are block-level processing related to symbol duration – some may not be present

See next slide for details

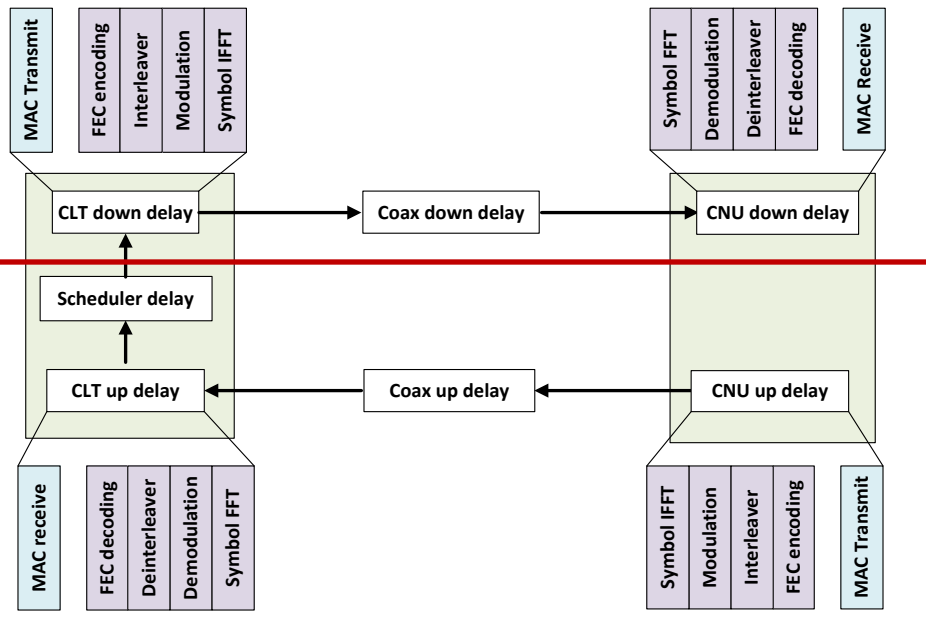

Delay Model – PHY for FDD upstream (cont.)

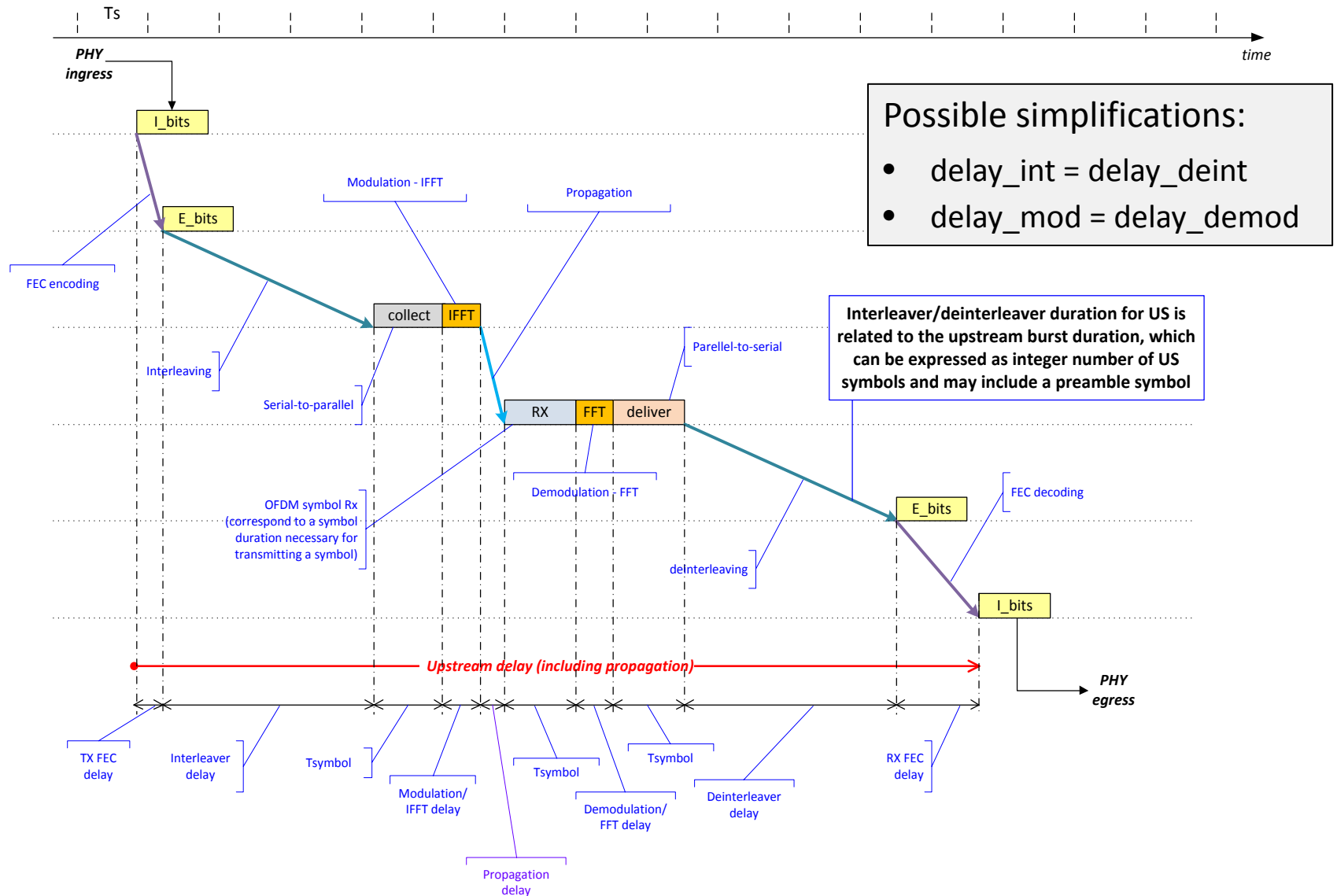

Note: Propagation delay depends on the cable plant and can vary significantly – this is just an example.

Delay Model – PHY for FDD summary

In case of FDD, the delay model results in the following terms:

$$\text{FDD_PHY_delay_DS} = T_{\text{encode}} + 2 * T_{\text{FDD_DS_Int}} + 3 * T_{\text{DS_symb}} + 2 * T_{\text{mod_FFT}} + T_{\text{decode}}$$

$$\text{FDD_PHY_delay_US} = T_{\text{encode}} + 2 * T_{\text{FDD_US_Int}} + 3 * T_{\text{US_symb}} + 2 * T_{\text{mod_FFT}} + T_{\text{decode}}$$

$$T_{\text{propagation_oneway}} = L_{\text{cable}} / (0.87 * c) \quad \text{where } c \text{ is the speed of light in vacuum}$$

Note: The following assumption and considerations holds

- Delay of interleaver and deinterleaver in one direction are the same
- Delay for modulation/IFFT and demodulation/FFT are the same
- Encoder/decoder are the same for DS and US
- Modulation/demodulation are the same for DS and US
- Different symbol duration for DS and US are possible
- Different interleavers for DS and US are possible
 - interleaver length is related to burst noise characteristics and in case of US the transmission burst may be equal or a multiple of the interleaver length
 - US interleaver from multiple CNU's may be inefficient against burst noise

Delay Model – PHY for TDD

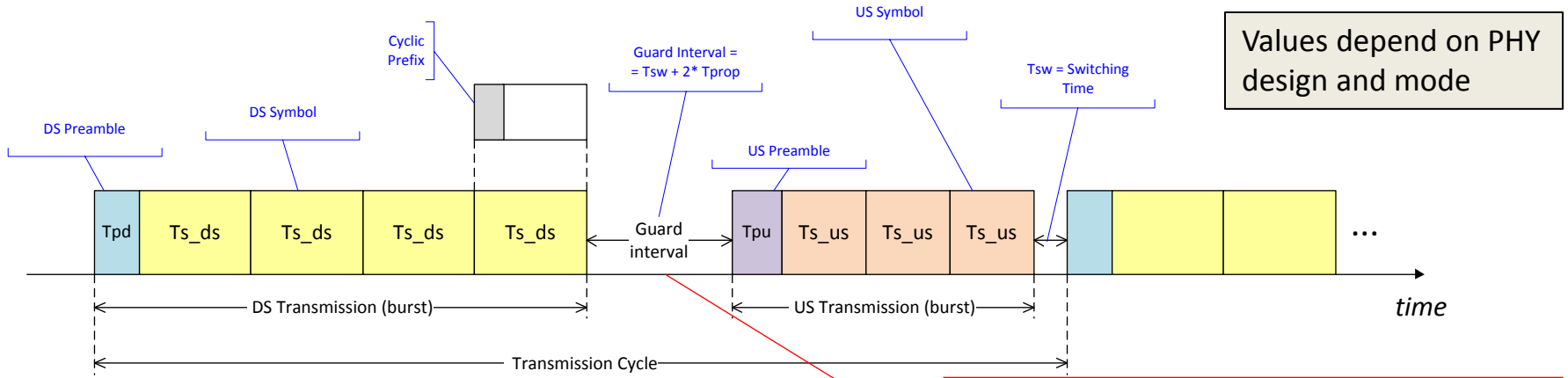

BP - If fixed US/DS TDD cycle timing, guard interval also needs to be extended by a complete packet length to avoid packet fragmentation

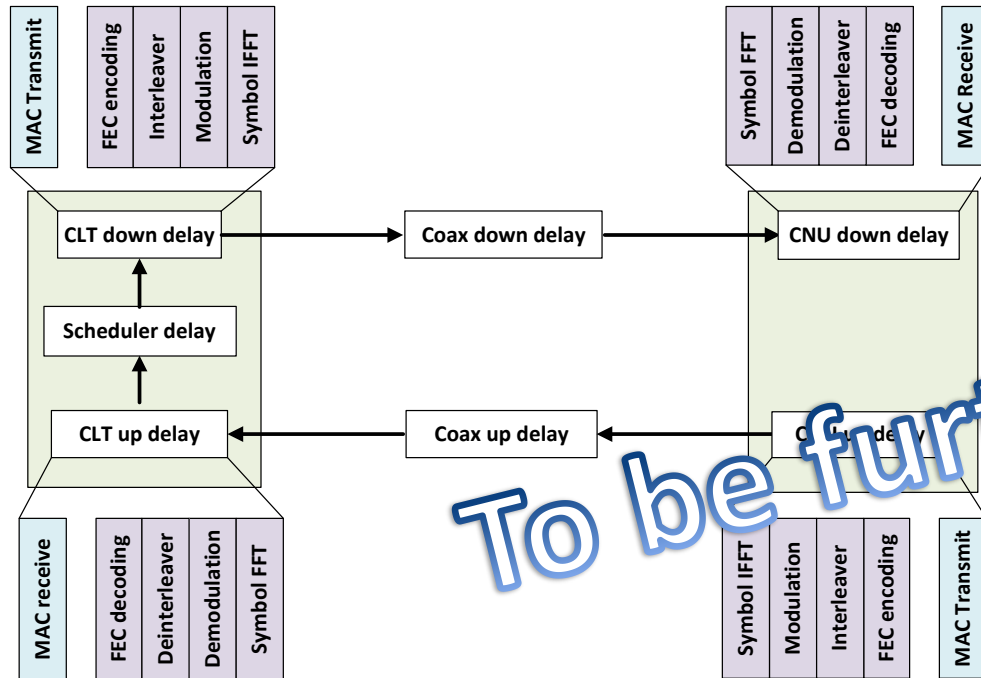

To be further refined

Generally speaking the PHY needs to perform operations for:

- FEC encoding/decoding
- Interleaving/de-interleaving
- Modulation/demodulation
- Symbol IFFT/FFT

Some of the operations are block-level processing related to symbol duration – some may not be present

Delay Model – PHY components (cont.)

- ...

Capture here PHY
explanations and
formulas as needed

Delay Model – MAC/MPCP implications

- For simplicity, assumption is that each user has the same traffic profile and it is treated the same, with assigned resources in round-robin fashion
 - This is reasonable starting point, further refinement may be needed later
- Latency and jitter due to the MAC/MPCP components includes:
 - DS scheduler cycle and resource allocation
 - US polling cycle and resource allocation
 - Number of transmitters
 - Min/Max burst sizes
 - Report cycle

Delay Model – MAC/MPCP components (cont.)

- ...

Capture here MAC
explanations and
formulas as needed

Efficiency Model – ...

Backup Material

Delay Model – Q&A to the group @ 27-July-2012

- Q1:** First priority should be the worst case within a reasonable scenario (e.g. multiple users in a system, taking the worst case in there): is any need to also consider typical case? If yes, what could be a definition of such typical case?
- A1:** *The conclusion is to have worst case in realistic multi-user scenario and exclude corner cases – can be seen as typical scenario, 99%-tile. Still some open points:*
- (1) Max 1 Gb/s BW PAR Objective: to an individual CNU? Or to multiple CNUs on a coax segment? If multiple CNUs, max to an individual CNU?*
 - (2) Consider max optical distance on HFC network – inputs needed, specification states at least 10-20 km of fibers needs to be supported in EPON, depending on scenario (clause 56.1.3)*
- Q2:** The main objective is to analyze the delay in the PHY -> proposed reference points are from (a) packet leaves the MAC and enter the PHY in the transmitter to (b) packets leaves the PHY and is delivered to the MAC in the receiver. Once the PHY delay is modeled, the implication that this has on the MAC are also considered so that the overall delay = f(PHY, MAC) is modeled and compared with the requirements
- A2:** *Proposed reference points and way forward are fine for the exercise. Agreed to start with coax PHY delay components and then implications and highlight transmit/receive sides separately*
- Q3:** It is proposed to focus on coax part: like to hear opinion about including also the optical part and the OCU later on or not
- A3:** *Will start with coax modeling, and consider adding the optical part later. OCU model may be reduced to a simple delay component to play with.*
- Q4:** For simplicity we are planning to do the analysis for a system with equal traffic distribution. Like to hear if that is sufficient or other traffic profile should be selected.
- A4:** *Equal traffic (all users treated the same) is good place to start with, will include a variable number of transmitters in the model. Later additional cases may be added and consider asymmetric traffic.*