

IEEE 802.3 Maintenance

July 21st, 2005
San Francisco, CA

David Law
David_Law@3Com.com

Activities this week

- Met Wednesday morning
 - Reviewed status of existing revision requests
 - All IEEE P802.3REVam request set to Approve
 - Considered 10 new revision requests
 - 4 Ready for ballot (1161, 1163, 1164, 1168)
 - 1 Withdrawn (1160)
 - 4 Awaiting clarification of text (1162, 1165, 1166, 1167)
 - 1 Awaits other events for review (1159)

Review of new request

#	Reference	Description	
1159	57	OAM Discovery state diagram	R
1160	30.11.2.1	Additional attribute aTCCRCErrors	W
1161	Fig 33C.6	Figure 33C.6 Title	B
1162	33.2.8.8	Short circuit Output current	CB
1163	33.2.3.1	Alternative A detection timing	B
1164	Fig 33C.11	Align informative figure with normative text	B
1165	33C.1.4	Capacitive load for inrush current test	CB
1166	33C.16	Test procedure PSE-14 test setup	CB
1167	Fig 33-6	New state diagram option for short circuit condition	CB
1168	Clause 14, 25, 40 and 33	DTE Power via MDI isolation requirements	B

R – Received
W – Withdrawn

B – Ready for ballot
CB – Clarify then ready for ballot

1168 - Comparison of requirements

	Isolation from all MDI leads to	AC and DC test			Impulse test	
		Vrms	Vdc	Test method	Impulse	Defined
10BASE-T	Frame ground and PHY device circuits	1500V	2250V	5.3.2 of IEC 60950:1991	2400V 1.2/50 us	IEC 60060
10BASE-T The PI of a PD within its MDI	Frame ground and all external conductors					
100BASE-T ^{Note1}	Frame ground	1500V	2250V	5.3.2 of IEC 950:1991	2400V 1.2/50 us	IEC 60
1000BASE-T	Frame ground and PHY device circuits	1500V	2250V	5.3.2 of IEC 60950:1991	2400V 1.2/5 us	IEC 60060
1000BASE-T The PI of a PD within its MDI	Frame ground and all external conductors					
DTE Power via MDI	PI Device circuits	1500V	Not allowed	6.2 of IEC 60950-1:2001	1500V 10/700 us	6.2.2.3 of IEC 60950-1:2001

Note 1 - see FDDI TP-PMD standard, ANSI X3.263: 1995 (TP-PMD).

'PI Device circuits'

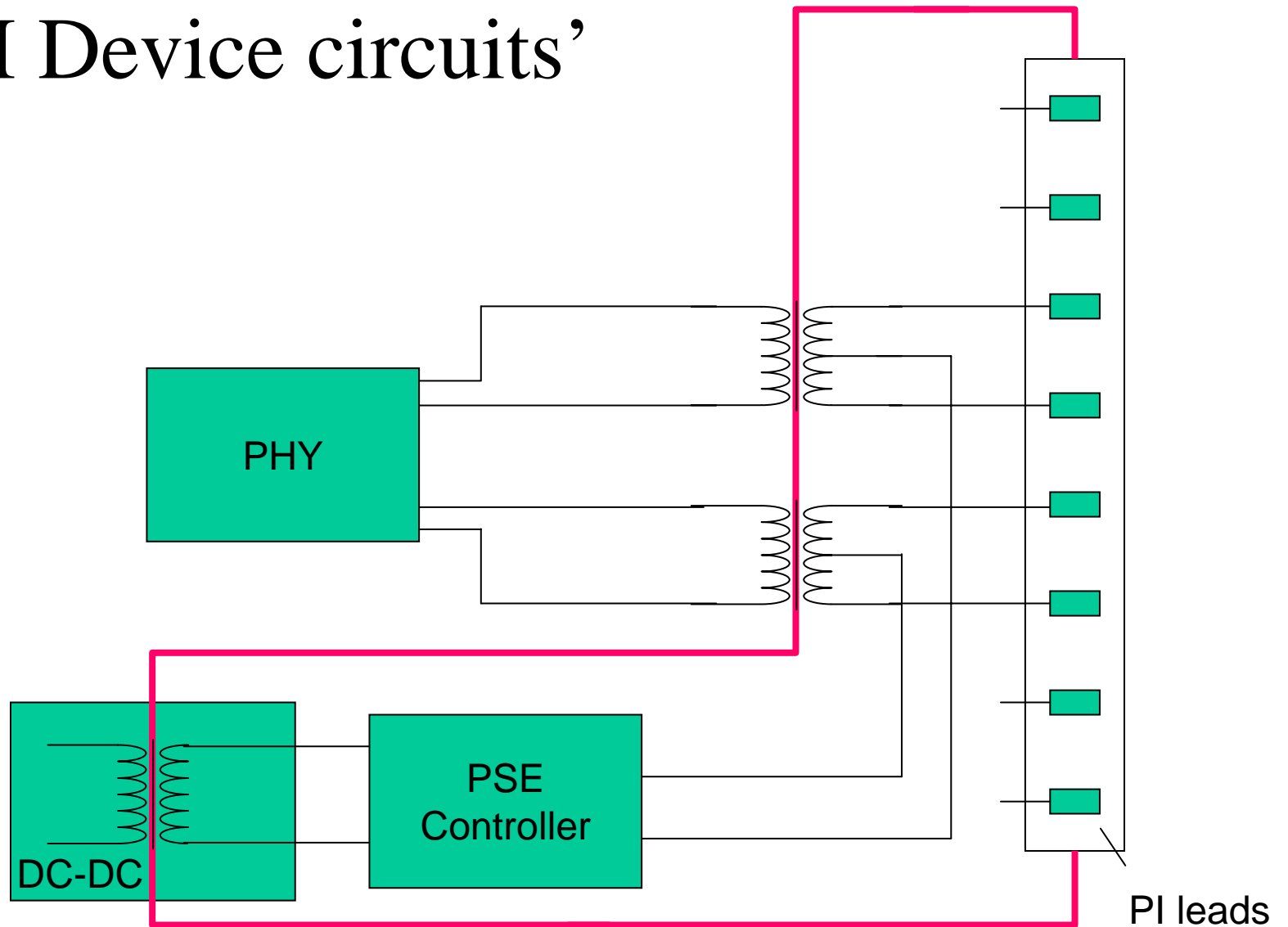

History

- First presented at May 2005 PoE+ interim
 - Objective added to PoE+

That IEEE 802.3af power over the MDI isolation requirements be revisited as part of the PoE Plus work.
- Formed IEEE 802.3 PoE+ Isolation Ad Hoc
 - Met Tuesday afternoon
 - IEEE 802.3 PoE+ did not meet during this time
 - Generated maintenance request
 - Request maintenance committee start corrigendum project
 - Corrigendum required due to urgency

IEEE P802.3 PoE+

Isolation Ad Hoc Motion 1

Request maintenance committee start corrigendum project to address Isolation in DTE Power via MDI and associated MAU and PHY isolation requirements.

M: Darshan S: Barrass

Y: 21 N: 0 A: 1

IEEE P802.3 PoE+ Isolation Ad Hoc Motion 2

Group to submit maintenance request contained
in:

http://www.ieee802.org/3/poep_study/public/jul05/law_2_0705.pdf

M: McCormack

S: Grow

Y: 22

N: 0

A: 0

IEEE P802.3auCorr1

Isolation corrigendum

- **Title:** Information technology— Telecommunications and information exchange between systems— Local and metropolitan area networks—Specific requirements— Part 3: Carrier Sense Multiple Access with Collision Detection (CSMA/CD) access method and physical layer specifications Corrigendum 1
- **Scope:** Clarify and correct isolation text including harmonization for both powered and unpowered Media Dependent Interfaces
- **Purpose:** Current text is technically not implementable for powered interfaces, and implementers must now make common sense deviations from the specifications of 802.3 to build power sourcing equipment.

IEEE P802.3auCorr1

Isolation corrigendum

- Timeline

PAR approval	September 2005
Final request review	September 2005
Working Group Ballot	November 2005
Sponsor Ballot	February 2006
Standards board approval	May 2006

IEEE 802.3 Motion

IEEE 802.3 approves the PAR as submitted for IEEE P802.3auCorr1 Isolation Corrigendum

IEEE 802.3 requests the IEEE 802 LMSC Executive Committee to submit the IEEE P802.3auCorr1 Isolation Corrigendum PAR to NESCOM.

M: Law S: Booth

Tech 75%/Proc ~~50%~~

PASSED/FAILED

Y: 83

N: 0

A: 10

Note:- As a maintenance PAR this did not need to meet the normal LMSC Executive committee pre-submittal requirements.

Maintenance Web Information

- The Maintenance web site is at:

<http://www.ieee802.org/3/maint/index.html>

- The Maintenance request form is available at:

http://www.ieee802.org/3/private/maint/revision_request.html

Username:

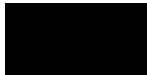

Password:



Password is case sensitive