

CFM in Backbone Edge Bridges

Norman Finn

P802.1ag/D7.1 Figure 22-1

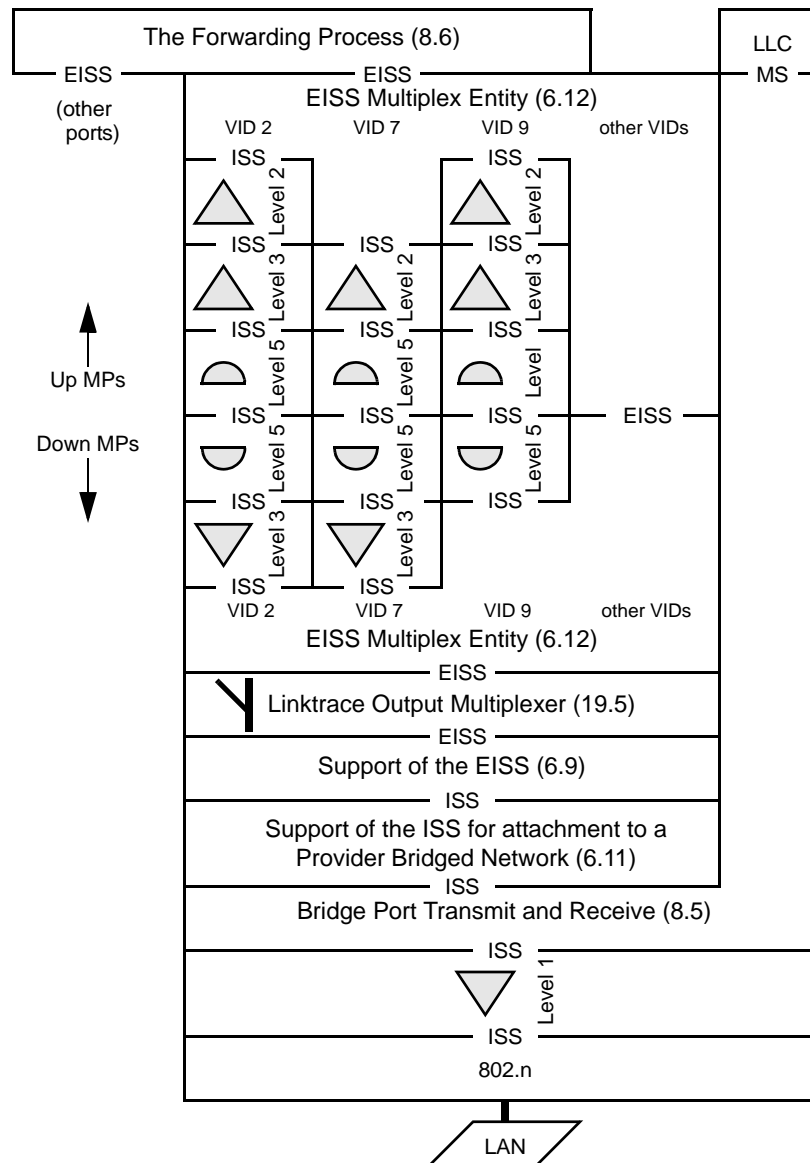
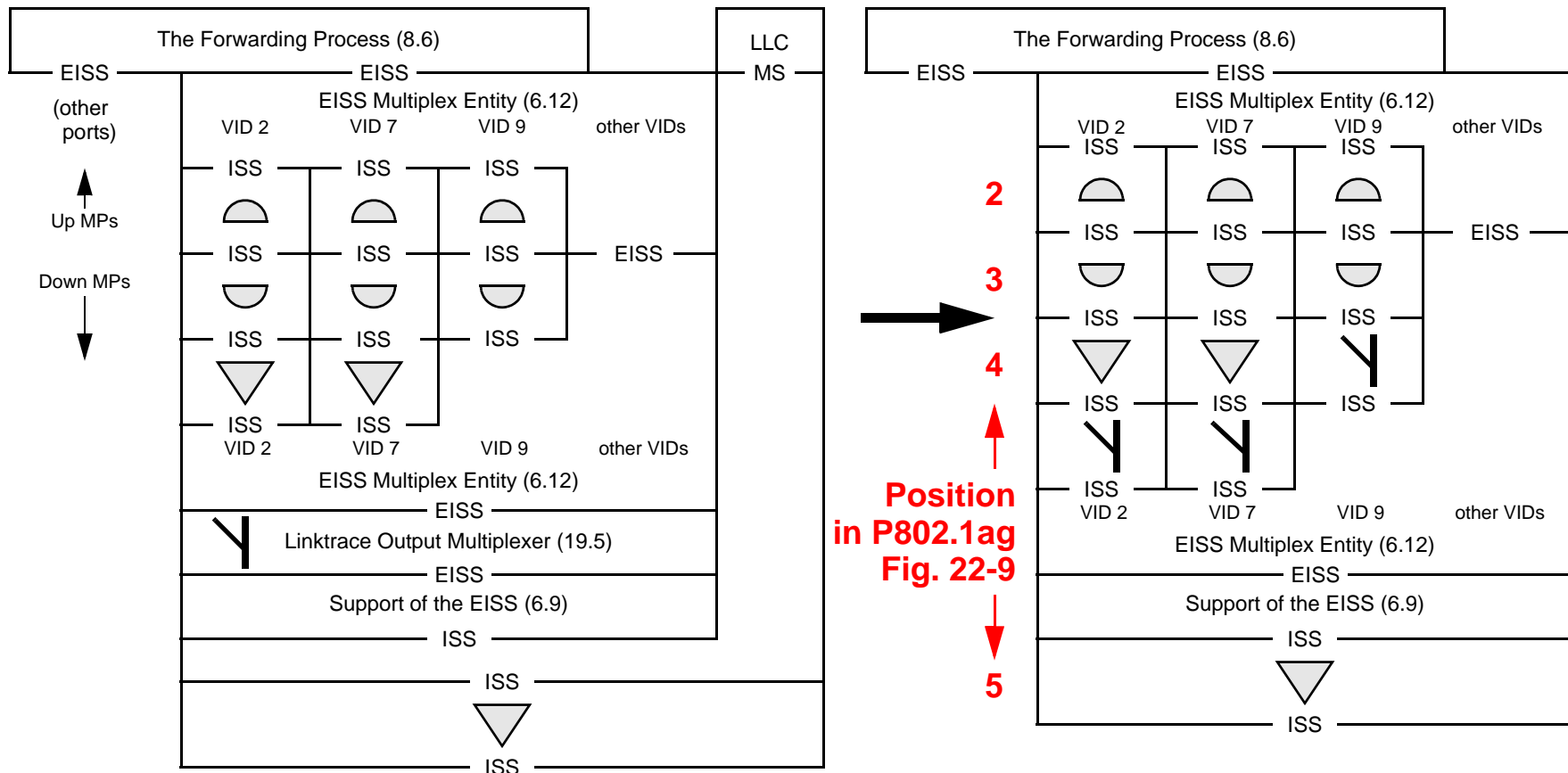

Figure 22-1—MEPs and MIPs distinguished by VID (incomplete picture)

Fig. 22-1 trimmed down to relevant parts



- **LOMs moved up and demultiplexed to concentrate the CFM for the purposes of this discussion — this causes no change to the function or intention of .1ag or .1ah.**

Obvious I-Component MPs

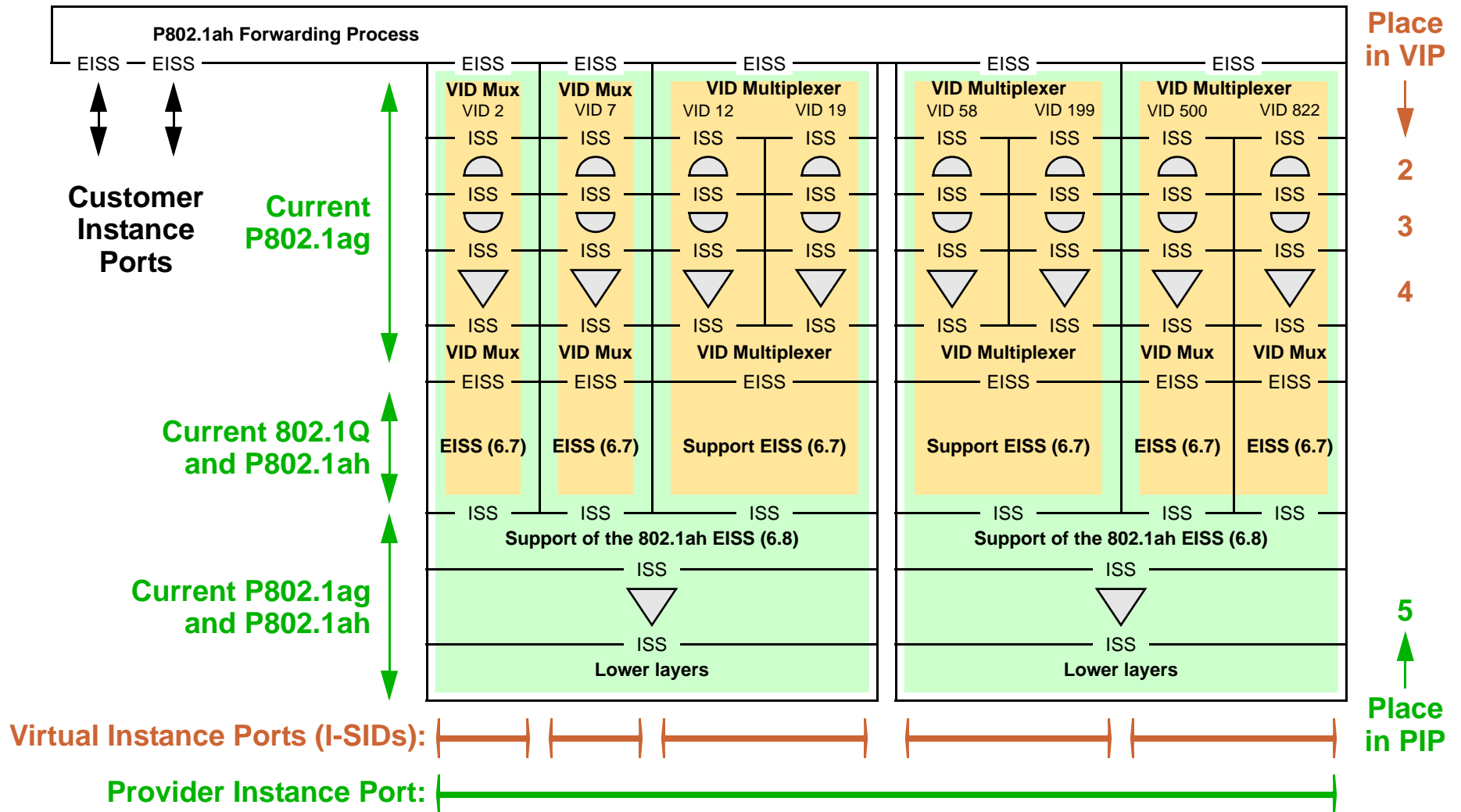

I-Component with per I-SID MEPs

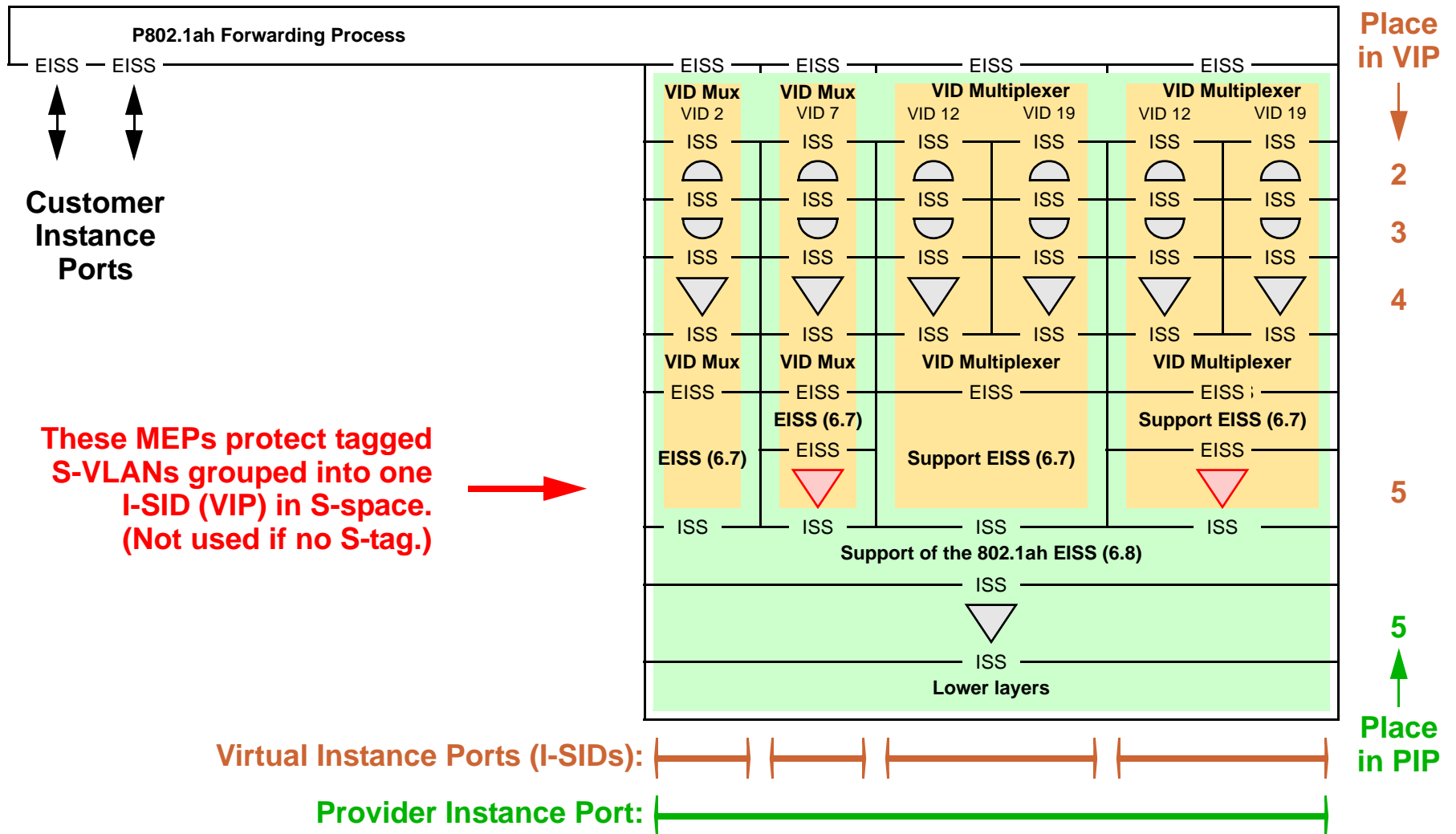

I-Component & peered B-Component

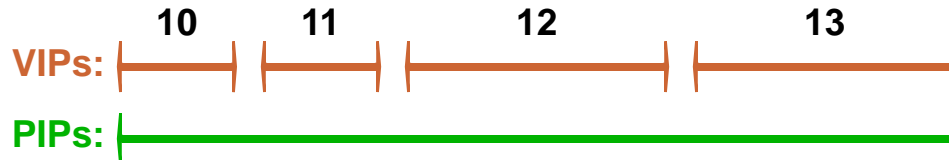
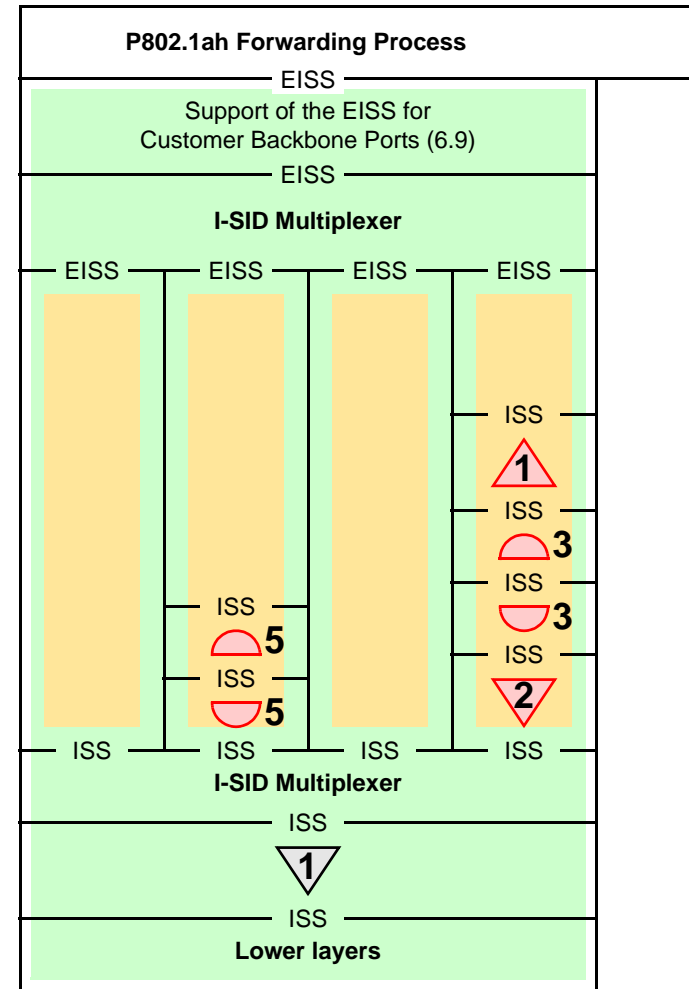
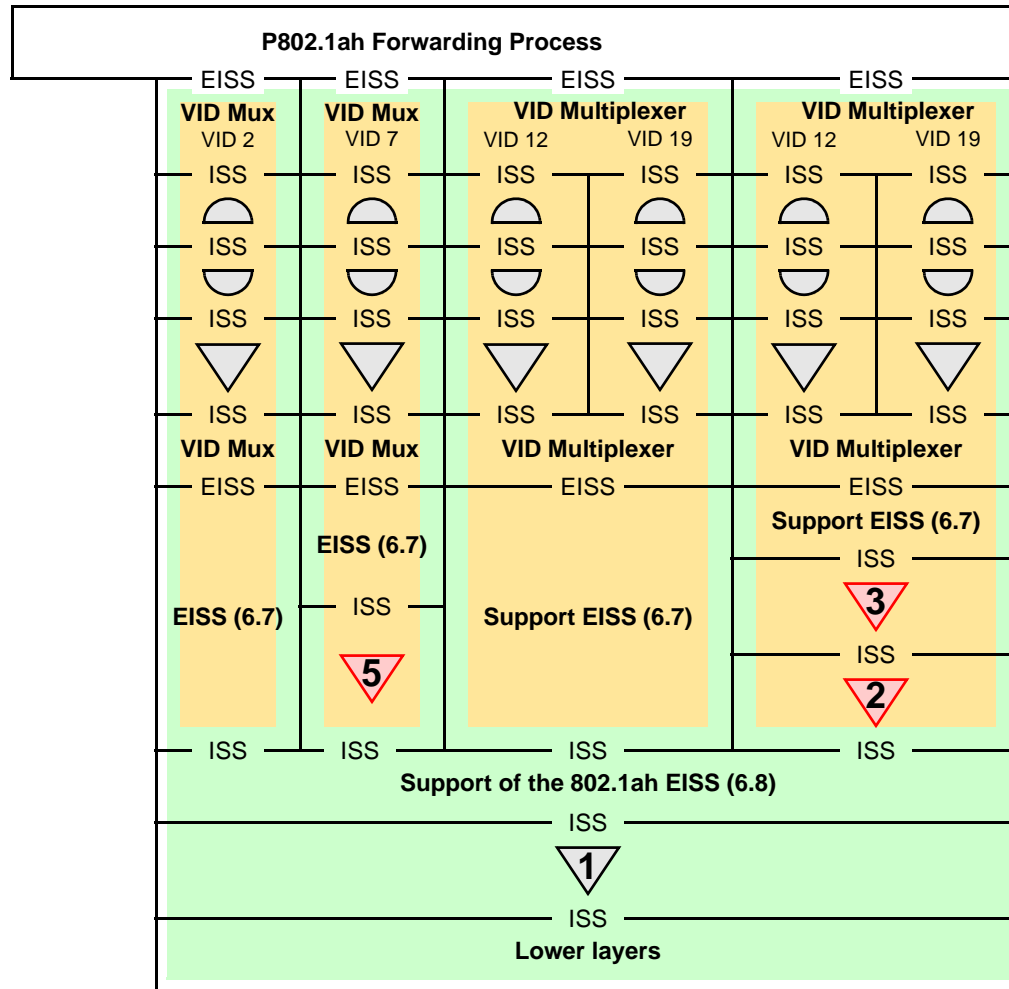

MD Levels in black: 3 2

MAC Address Spaces

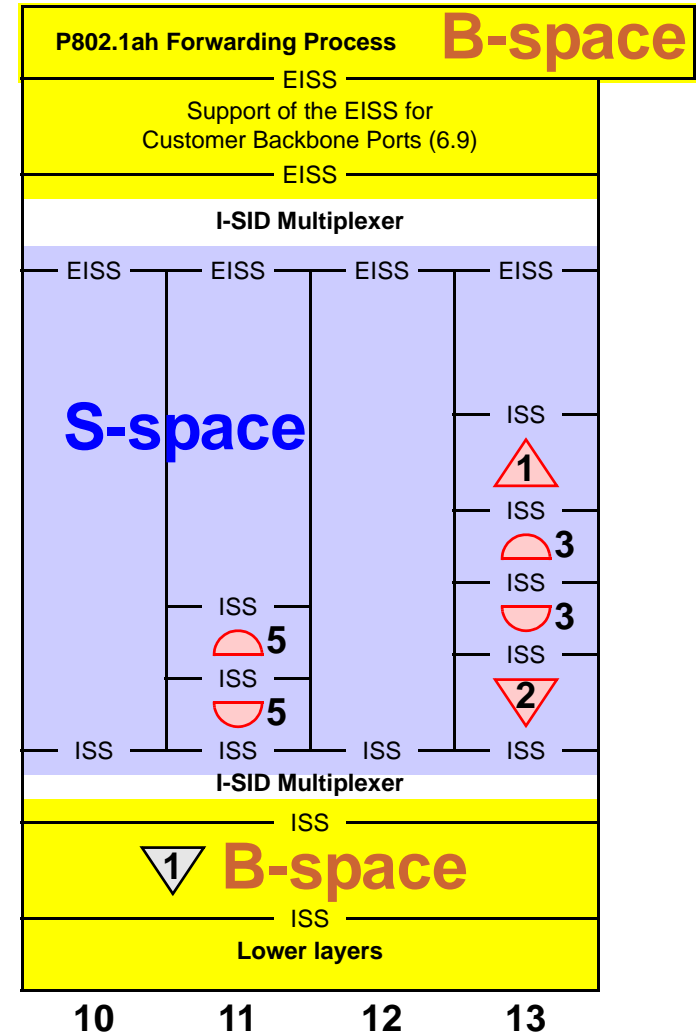
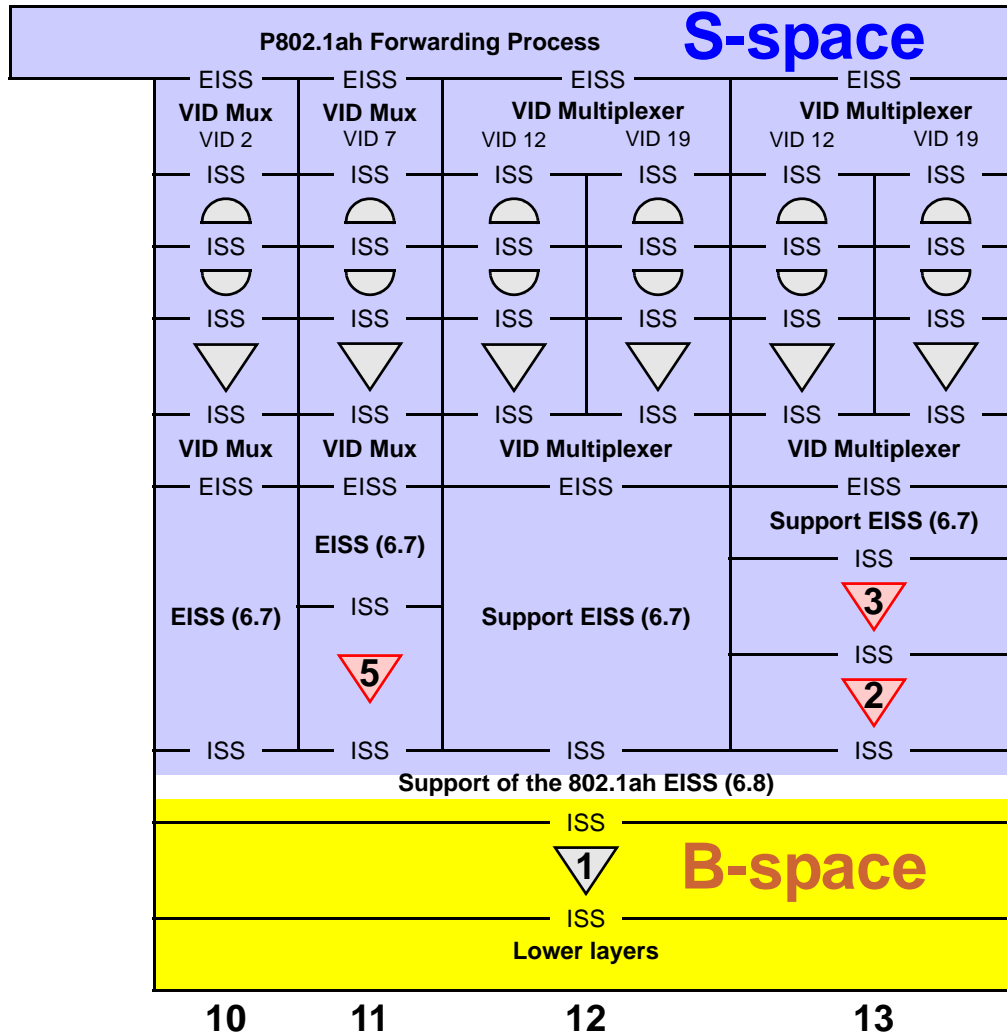

- **S-Space (.1d) and B-Space (.1ah backbone)**

Conclusion

- **CFM does not raise a requirement to define a new form of the I-tag.**