



DCB Capability eXchange Protocol: DCBCXP Overview

Manoj Wadekar

January 2008

Contributors

- Parag Bhide, Emulex
- Craig Carlson, Qlogic
- Claudio Desanti, Cisco
- Dinesh Dutt, Cisco
- Uri Elzur, Broadcom
- Anoop Ghanwani, Brocade
- Bruce Klemin, Qlogic
- Mike Ko, IBM
- Joe Pelissier, Cisco
- Renato Recio, IBM
- J. R. Rivers, Nuova
- Ravi Shenoy, Emulex
- Pat Thaler, Broadcom



DCBCXP Overview

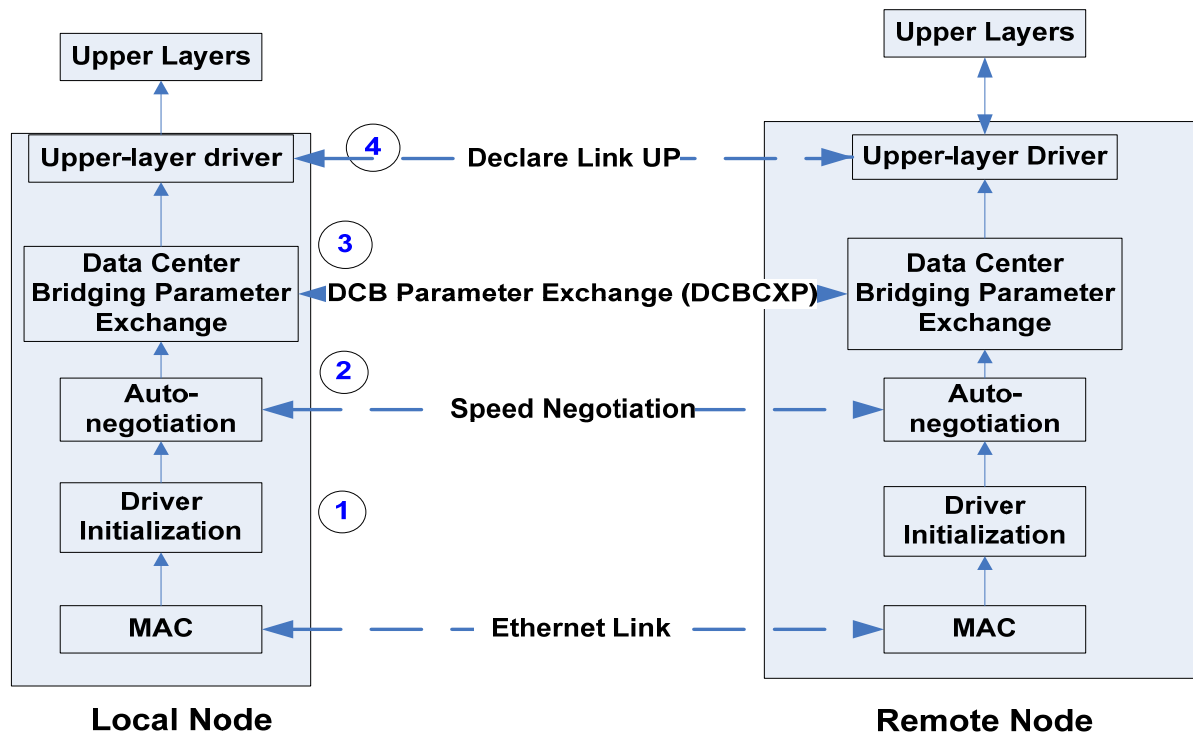

- DCB Capability eXchange Protocol is responsible for configuration of link parameters for DCB functions
- It includes
 - A protocol to exchange (send and receive) DCB parameters between peers
 - Set local “operational” parameters based received DCB parameters
 - Resolve conflicting parameters

Parameter Exchange

- Based on LLDP (Link Level Discovery Protocol)
- Added reliable transport
- Link partners can choose supported features and willingness to accept configuration from peer

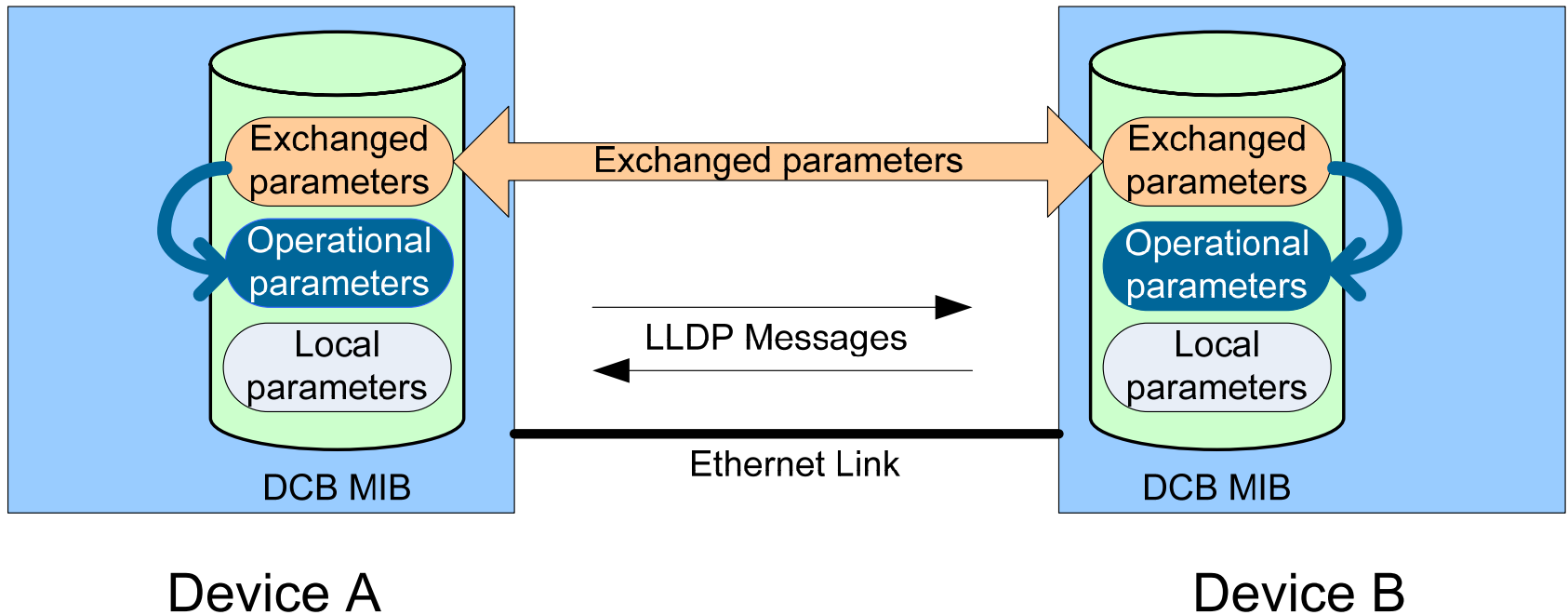

Exchanged MIB Parameters

- Feature TLVs
- Congestion Notification: 802.1Qau
- Priority Groups : 802.1Qaz
- Priority-based Flow Control : TBD

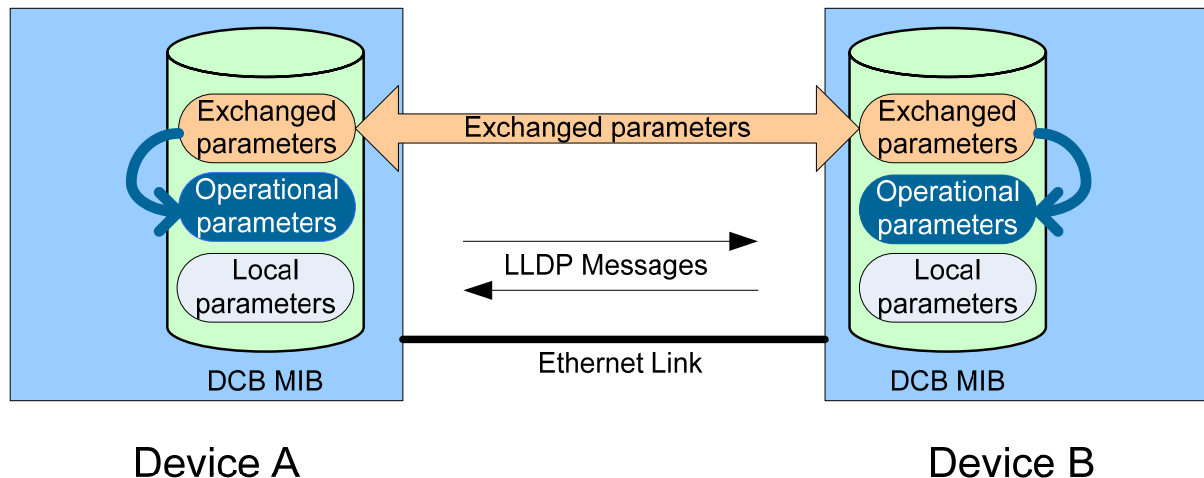

Priority Groups Tables

Parameter	Syntax	Range	Default Value	Access (RO,RW,NA)	Scope	Description
Priority Group (PG) Allocation	Table					
PG ID (index)	Integer	0..7		RW	Exchanged	Queue bandwidth group
PG Percentage	Integer	0..100		RW	Exchanged	Percentage of link bandwidth
Strict Priority	Integer	0..2		RW	Exchanged	Strict priority settings: 0 – no strict priority 1 –Strict Priority
User Priority Allocation	Table					
Priority (index)	Integer	0..7		RW	Exchanged	
PG ID	Integer	0..7		RW	Exchanged	BWG to which the priority belongs

PFC Table

Parameter	Syntax	Range	Default Value	Access (RO,RW,NA)	Scope	Description
PFC Config	Table					
User Priority (index)	Integer	0..7		RW	Exchanged	
Admin mode	Integer	0..1	0	RW	Exchanged	Administrative PFC mode. 0: Disabled 1: Enabled PFC Enabled means that flow control in both directions (Rx and Tx) is enabled.

Protocol and LLDP

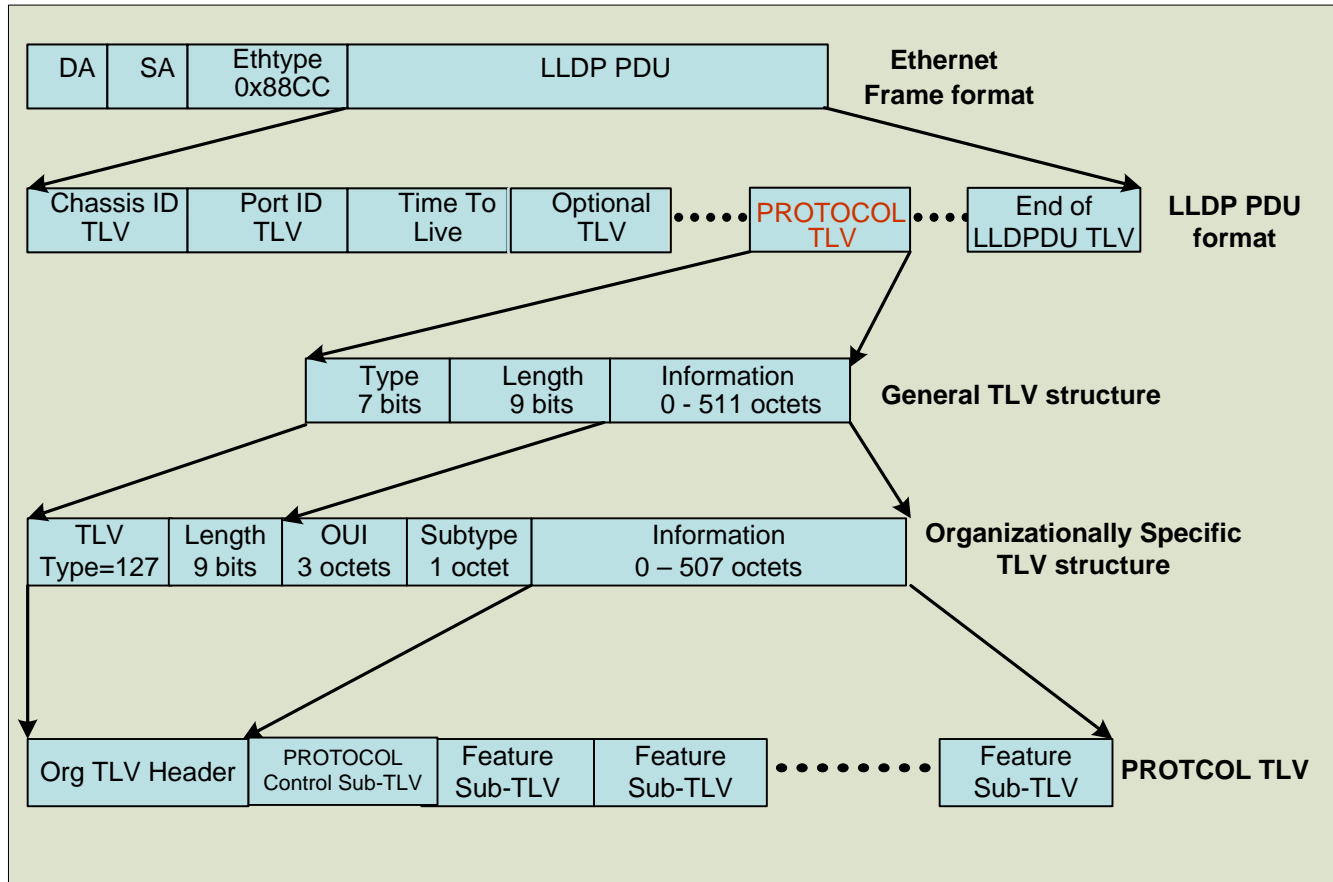

Proposed Next Steps

- Define base protocol that allows discovery and capability exchange
 - 802.1Qaz could be initial placement
 - We could start in March 2008 Plenary
- Each DCB protocol defines its relevant “feature” to be exchanged with protocol defined in 802.1Qaz
- All these projects get rolled in 802.1Q when next Rev happens
- Thoughts or suggestions?