

# 802.11 BSS Bridging

**Contributed by Philippe Klein, PhD**

Broadcom

IEEE 8021/802.11 Study Group, Aug 2012

new-phkl-11-bbs-bridging-0812-v3



# Coordinated Shared Network (CSN)

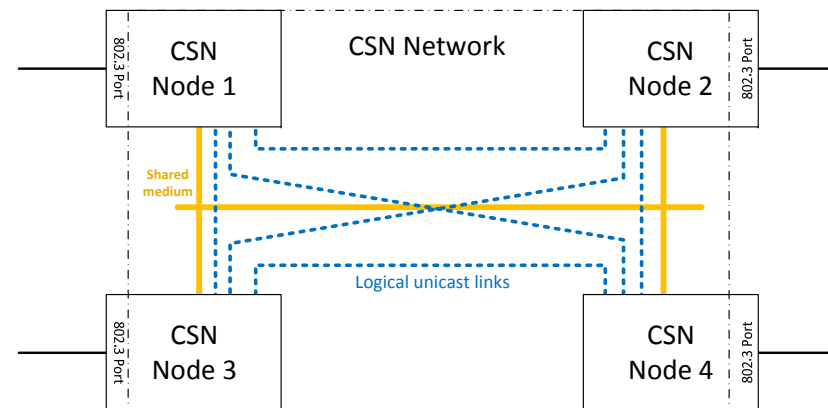

- Contention-free, time-division multiplexed-access, network of devices sharing a common medium and supporting reserved bandwidth based on priority or flow (QoS).
  - one of the nodes of the CSN acts as the network coordinator, granting transmission opportunities to the other nodes of the network.
- Physically a shared medium, in that a CSN node has a single physical port connected to the half-duplex medium, but logically a fully-connected one-hop mesh network, in that every node can transmit frames to every other node over the shared medium.
- Supports two types of transmission:
  - unicast transmission for point-to-point (node-to-node)
  - transmission and multicast/broadcast transmission for point-to-multipoint (node-to-other/all-nodes) transmission.

# CSNs behave as L2 Bridges...



L2 Bridge

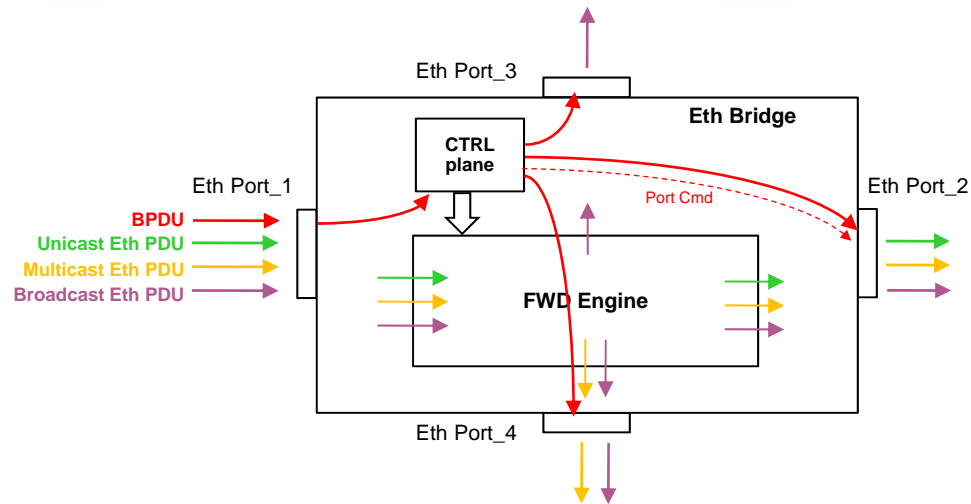

CSN Network

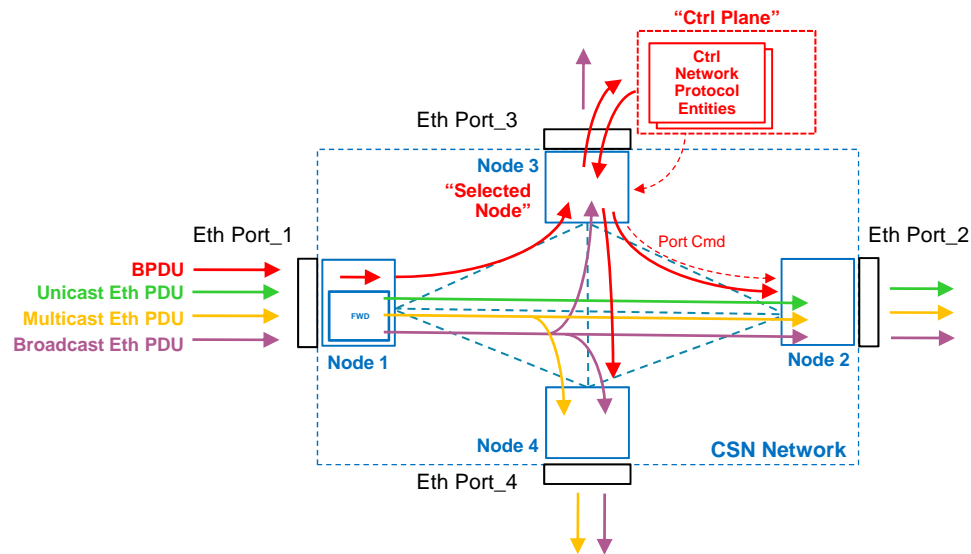

# CSN as Distributed Bridge - Pros



- Scalable:
  - Single bridge per CSN regardless # of nodes  
*vs P2P mesh where each node is a bridge*
- Optimized for “heavy”/”light” nodes
  - *(single ctrl plane node + n-1 “dumb” ports rather than n bridges)*
- No duplication of resources
  - 1 single Ctrl plane entity per CSN
- Reuse of standard L2 Ctrl protocol entities
  - requires only a simple adaptation layer  
(cf “White Paper: Control Plane Implementation on Coordinated Shared Networks (CSN)”  
<http://www.ieee802.org/1/files/public/docs2011/avb-phkl-wp-csn-ctrl-plane-1111-v01.pdf> )
- Support ranking
  - without modification of the underlying network protocol
- Network agnostic interface to underlying network
  - simple interface
  - CSN bridging method is kept “internal” *(including “node relaying” when applicable)*
- *This model is already used by MSRP for CSN and 802.11 BBS (IEEE 802.1Q-2011, Annex C)*

# MSRP Example

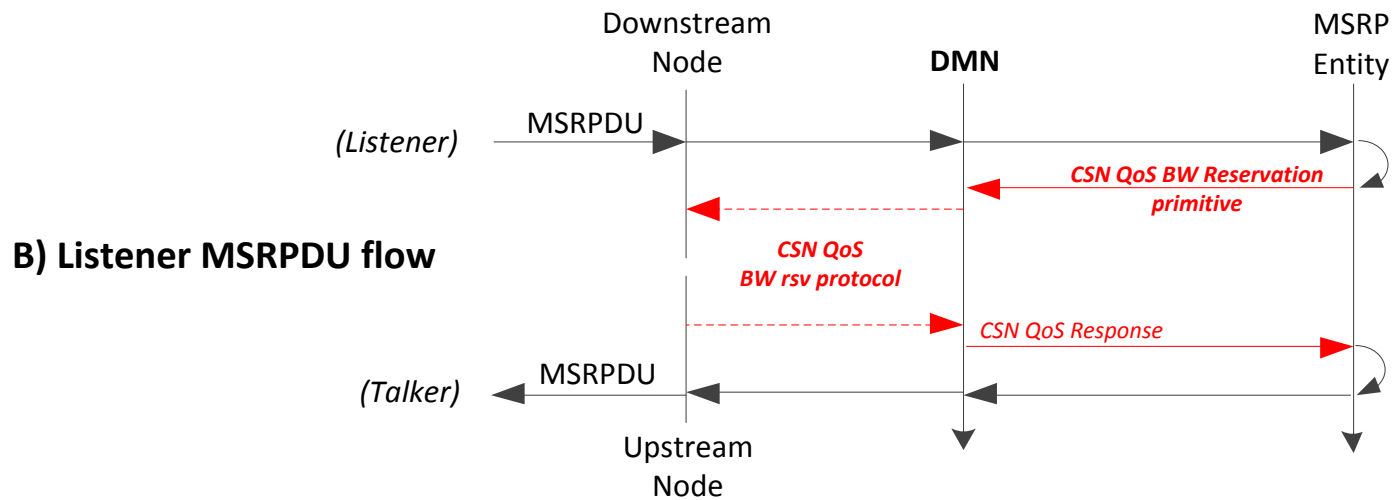
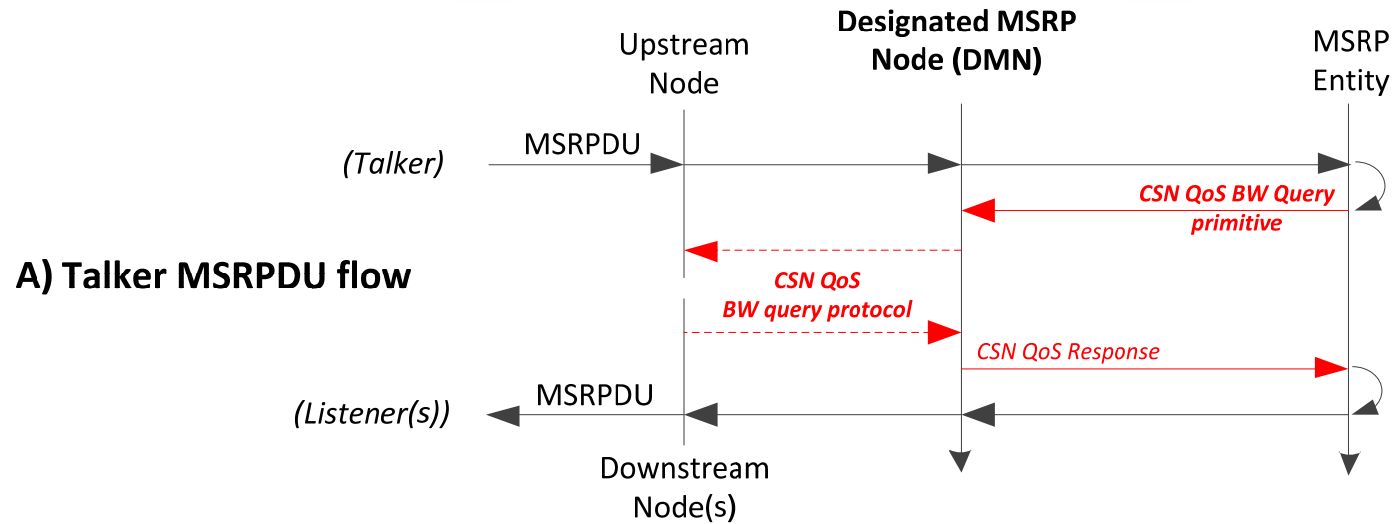

# Heterogeneous Networks are Bridged LANs



- 802.11 BSS handled as other CSN networks

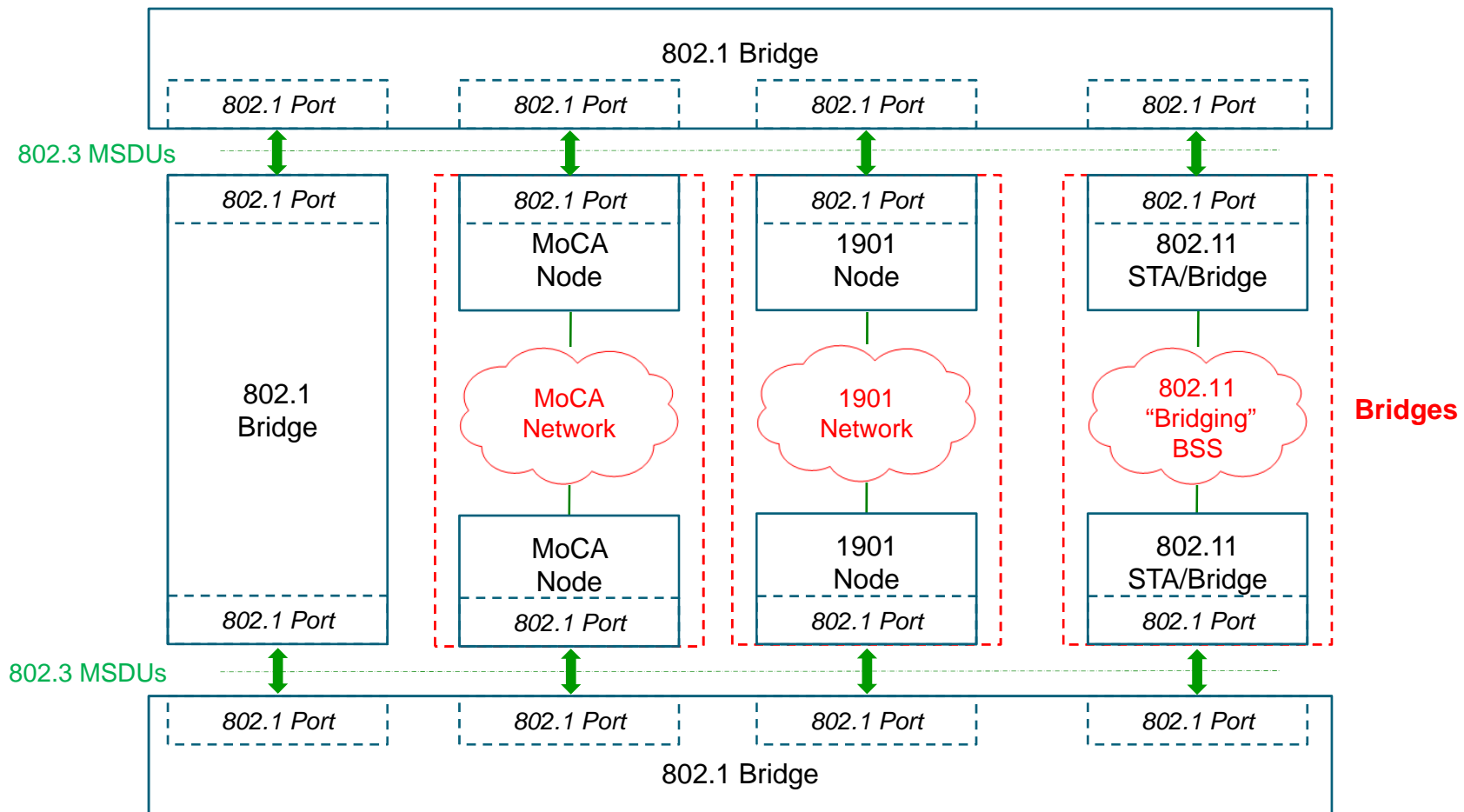

# Reminder – Model #1: P2P Link Model



## Set of point-to-point links

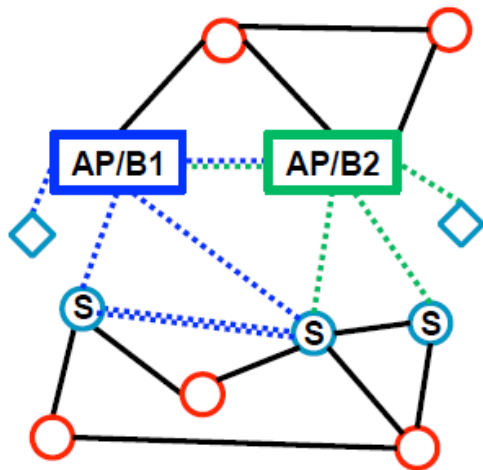

- The Access Points and their co-resident bridging functions become integrated AP bridges (AP/Bs).
- Devices with non-AP station capability(ies) and wired connections become “non-AP station bridges” (S).
- Of course, not all stations are bridges. (The diamonds are non-bridge non-AP stations.)

New-nfinn-11-medium-choice-0812-v02.ppt

For IEEE 802.1/802.11 bridging study groups, Aug. 2012

4

Source - Norm Finn's presentation [www.ieee802.org/1/files/public/docs2012/new-nfinn-11-medium-choice-0812-v02.pdf](http://www.ieee802.org/1/files/public/docs2012/new-nfinn-11-medium-choice-0812-v02.pdf)

# Reminder – Model #2 : Emulated LAN Model



## 802.11 LAN emulation

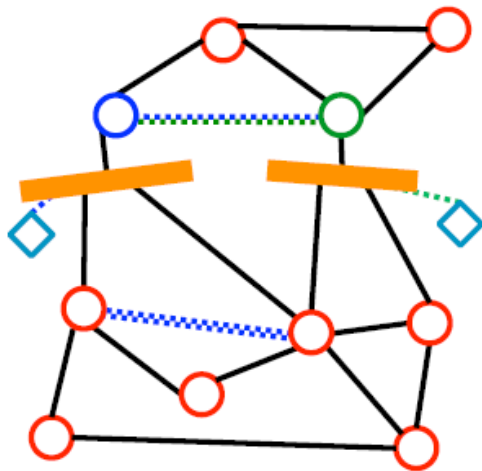

- Each AP and its stations emulate a shared medium LAN (fat yellow coax), as seen by the wired bridges.
- Each AP uses its bridge knowledge to optimize forwarding through the 802.11 medium, rather than broadcasting every frame.
- Direct AP-AP links have to be modeled separately from “coax”. Station-station links can be separate (shown) or part of emulated LAN.

New-nfinn-11-medium-choice-0812-v02.ppt

For IEEE 802.1/802.11 bridging study groups, Aug. 2012

5

Source - Norm Finn's presentation [www.ieee802.org/1/files/public/docs2012/new-nfinn-11-medium-choice-0812-v02.pdf](http://www.ieee802.org/1/files/public/docs2012/new-nfinn-11-medium-choice-0812-v02.pdf)



# Proposal - Model #3 : Emulated Bridge Model

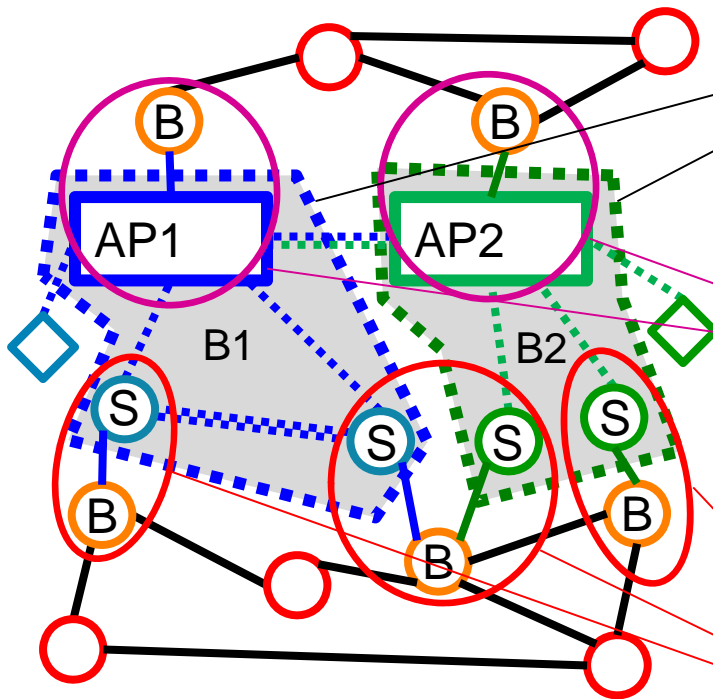

- Each BSS (Access Point and its non-AP stations) emulate a single, separated bridge [B1] [B2].
- An AP with wired connections is logically separated into an BSS bridge port (AP) and a wired bridge (B).
- Each non-AP station/bridge is logically separated into an BSS bridge port and a (virtual) wired bridge (B) (with wires to each component).

Based on slide, courtesy of Norm Finn

# BSS Bridging Model

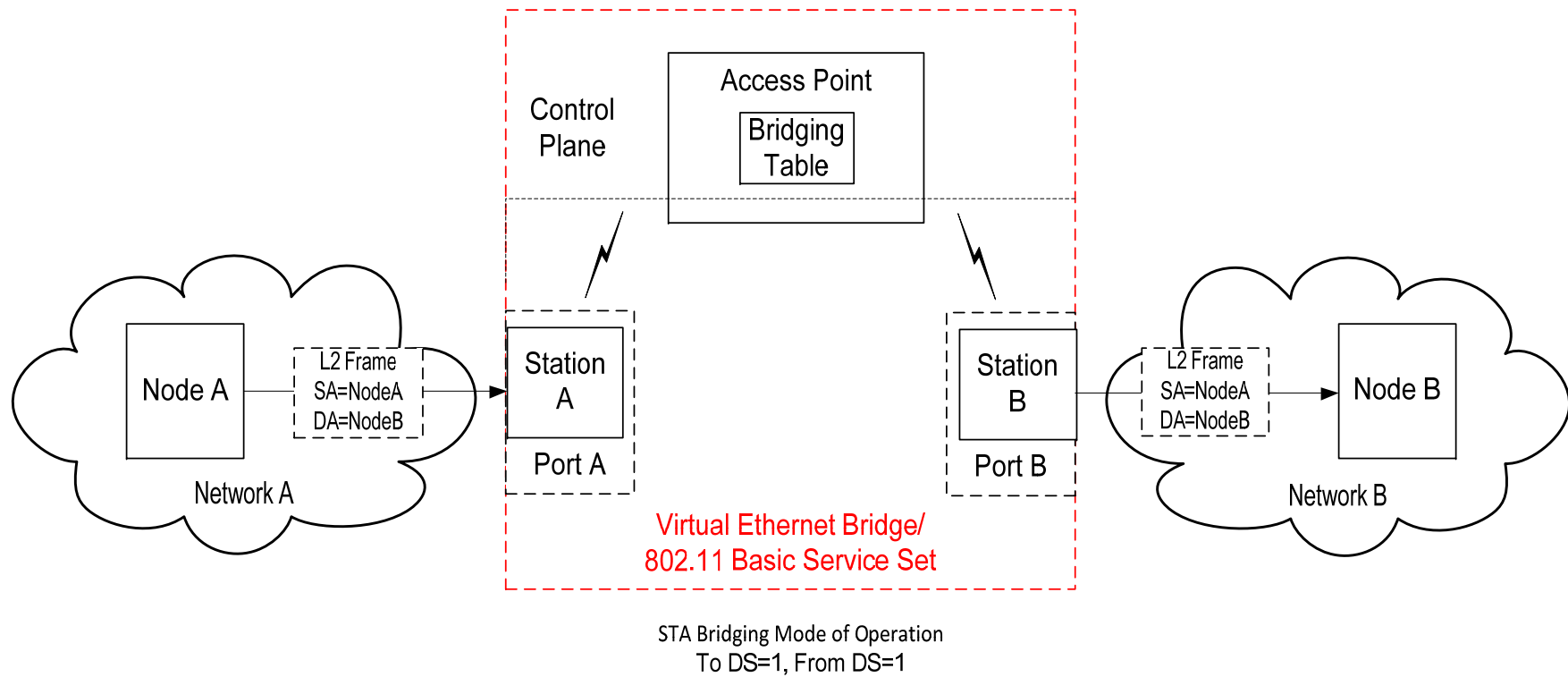

# BSS Bridging Model (Single Ctrl Plane)

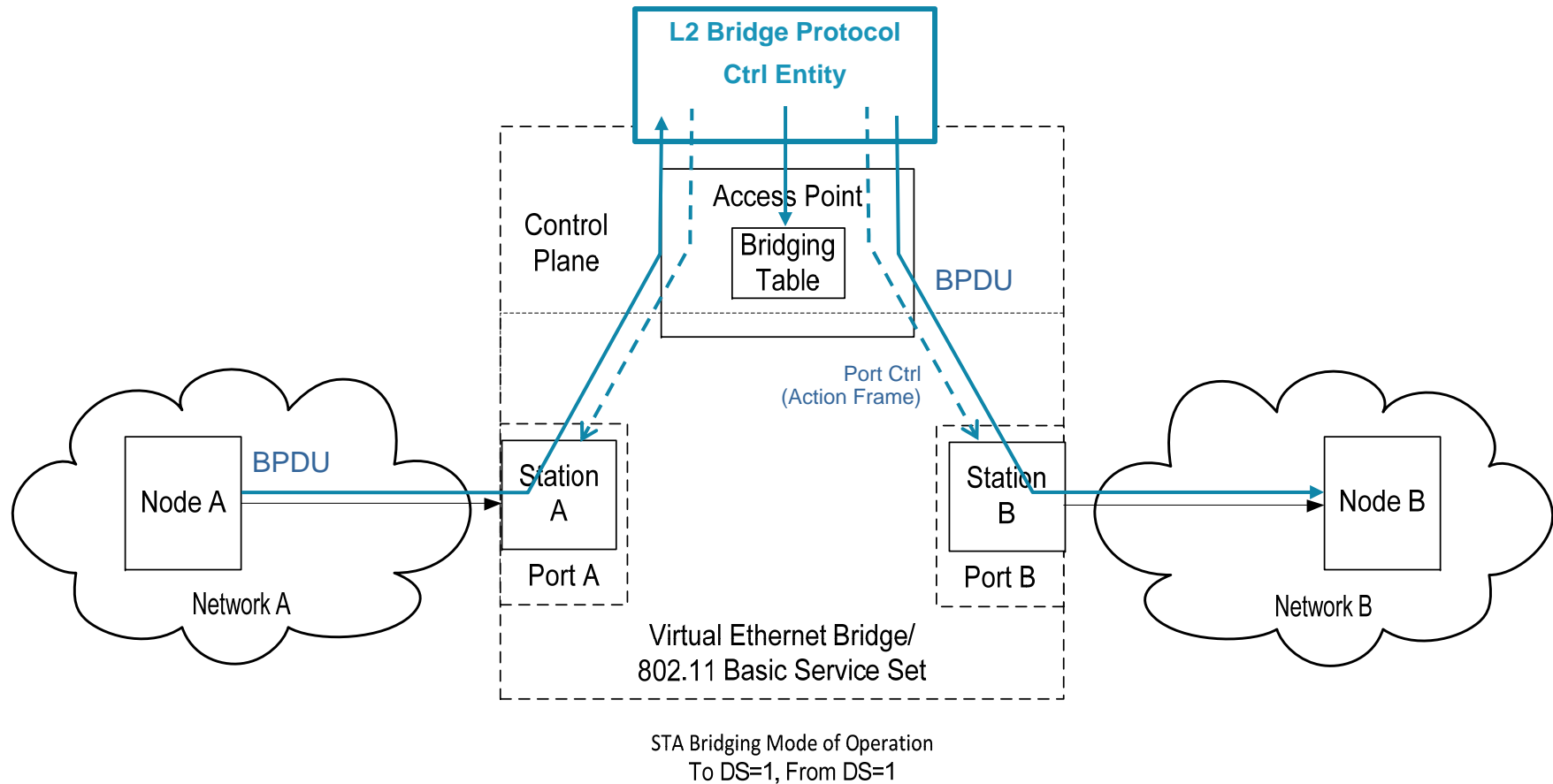

# New AP Bridging Traffic Type

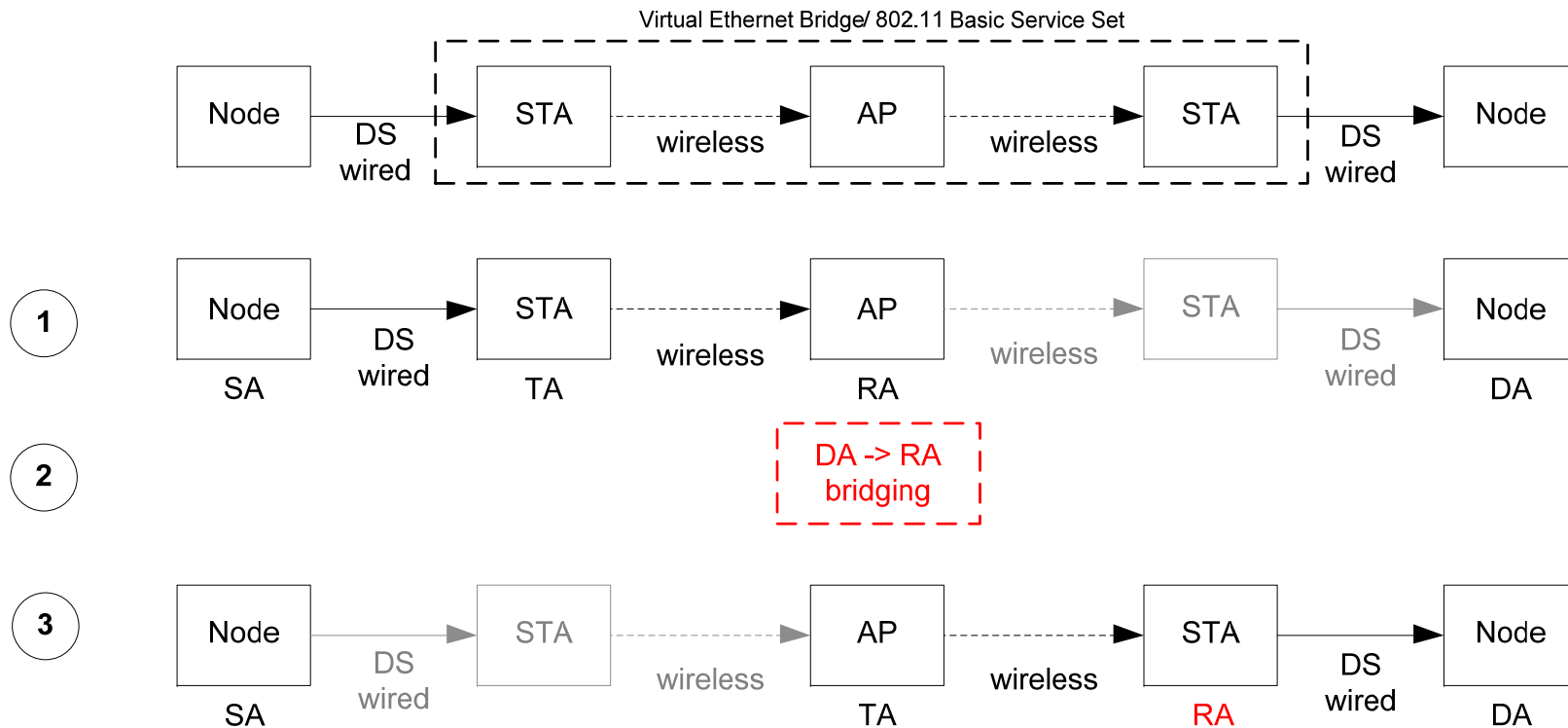

- The whole BSS is modeled as a distributed bridge overlaying the 802.11 protocol
  - AP acts as the Bridge's Control Plane
  - STAs act as Bridge Ports
  
- Modifications to 802.11 are limited to:
  1. [ToDS=Set , FromDS=Set] mode behavior redefined at ingress AP and ingress STAs
  2. Broadcast “Echo Cancellation” Method <TBD>  
*Could be:*
    - APs broadcast MSDUs without modifying the Sequence Number & STAs filter out broadcasted MSDUs they originated on SN matches
    - STAs filter out broadcasted MSDUs they originated on TID matches
  3. Additional Parameters to MLME-DLS primitives

# AP Bridging

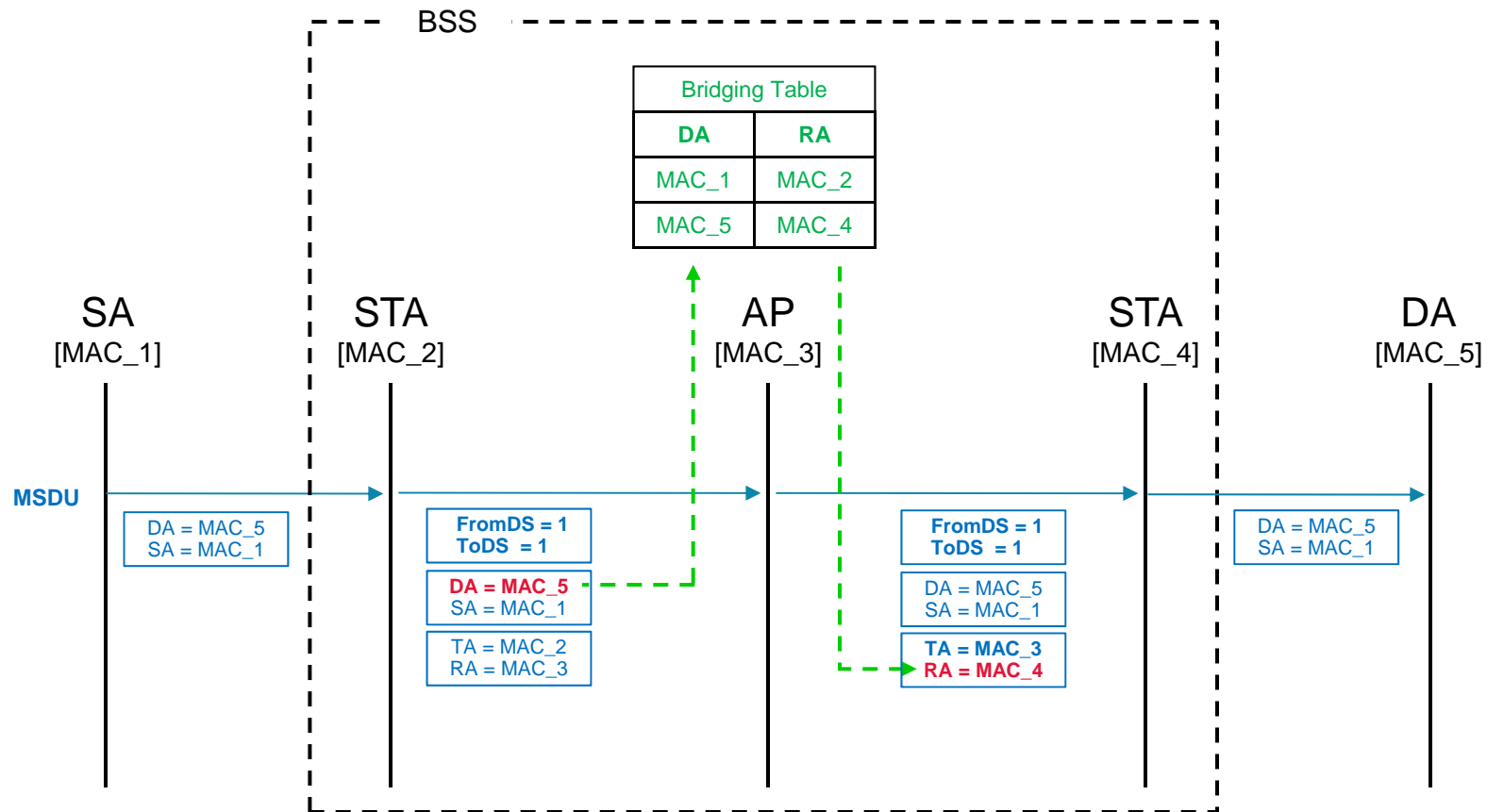

# ▶ Addition to the 802.11 Standard



- New Element in Beacon and Probe Response
  - AP indicates its BSS Bridging Capability in a new BSS Bridging Element in Beacon and Probe Response
  - AP BSS bridging Capability is controlled by a dot11BSSBridgingCapabilityEnabled parameter
- New Action Frames <TBD>
  - AP control to STA ports (i.e. block port...)

# New [To DS = Set, From DS = Set] Handling



- STA originated MSDU received by AP:
  - AP performs a lookup to the AP Bridging table with the Destination Address (DA) to retrieve the MAC address of the STA bridging the DA and use it as the Receiver Address (RA) of the forwarded MSDU
  - MSDU with unknown or Multicast DA addresses are broadcasted by the AP
- AP originated MSDU received by STA:
  - If the DA is a Broadcast/Multicast Address, the STA checks the MSDU Sequence Number or TDI ( to match any of the SNs (or TIDs) of the latest Multicast MSDUs by this STA:
    - If match, the STA discards the receive frame
    - Otherwise the STA extracts the (DA,SA) and uses them as the (DA,SA) of the MSDU bridged by the STA



# New DLS Bridging Traffic Type



Virtual Ethernet Bridge/ 802.11 Basic Service Set

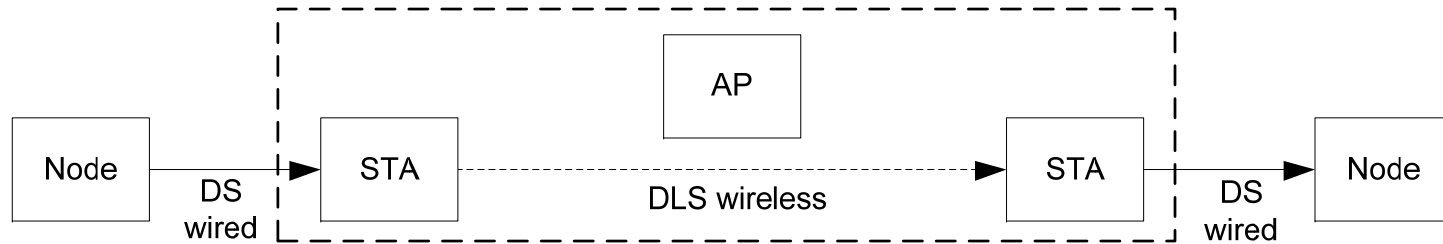

1

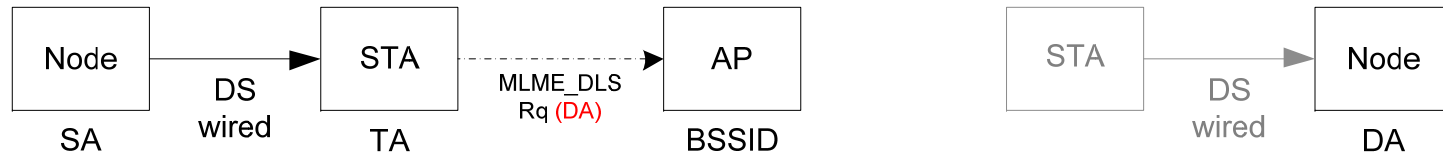

2

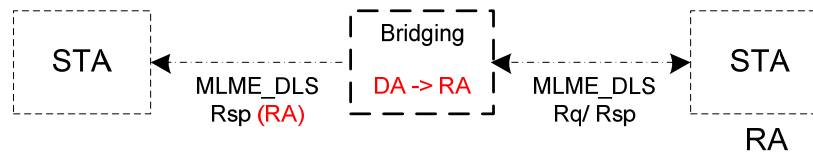

3



# DLS Mode Bridging



- For Direct Link Setup mode, a new MLME-**B**DLS request primitive could be specified with the DA MAC address replacing the STA MAC address as parameter:

```
MLME-BDLS.request (  
    PeerDAMACAddress,  
    DLSTimeoutValue,  
    DLSResponseTimeout)
```

- The associated confirm primitive returns the STA MAC address bridging the DA MAC address :

```
MLME-BDLS.confirm (  
    PeerDAMACAddress,  
    PeerSTAMACAddress,  
    ResultCode,  
    CapabilityInformation,  
    DLSTimeoutValue,  
    SupportedRates)
```

# GW Centric Home Network – P2P Model

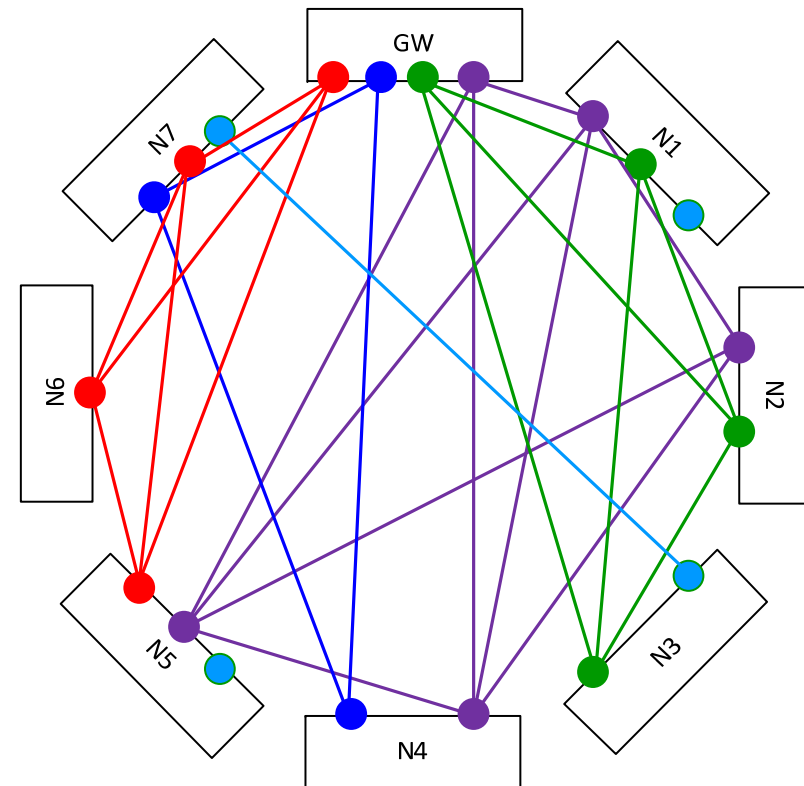
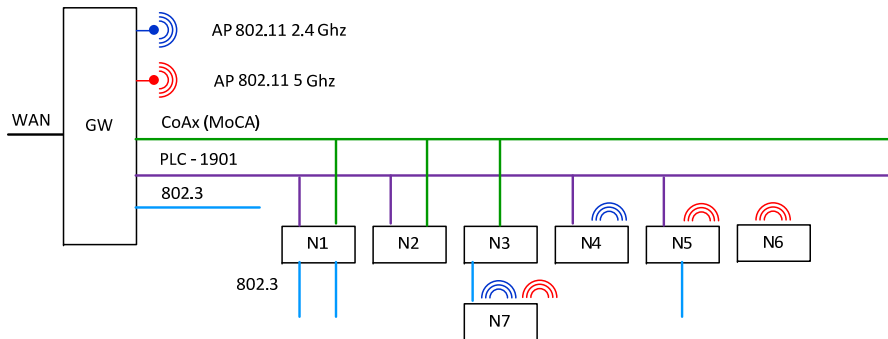

# GW Centric Home Network – Bridge Model

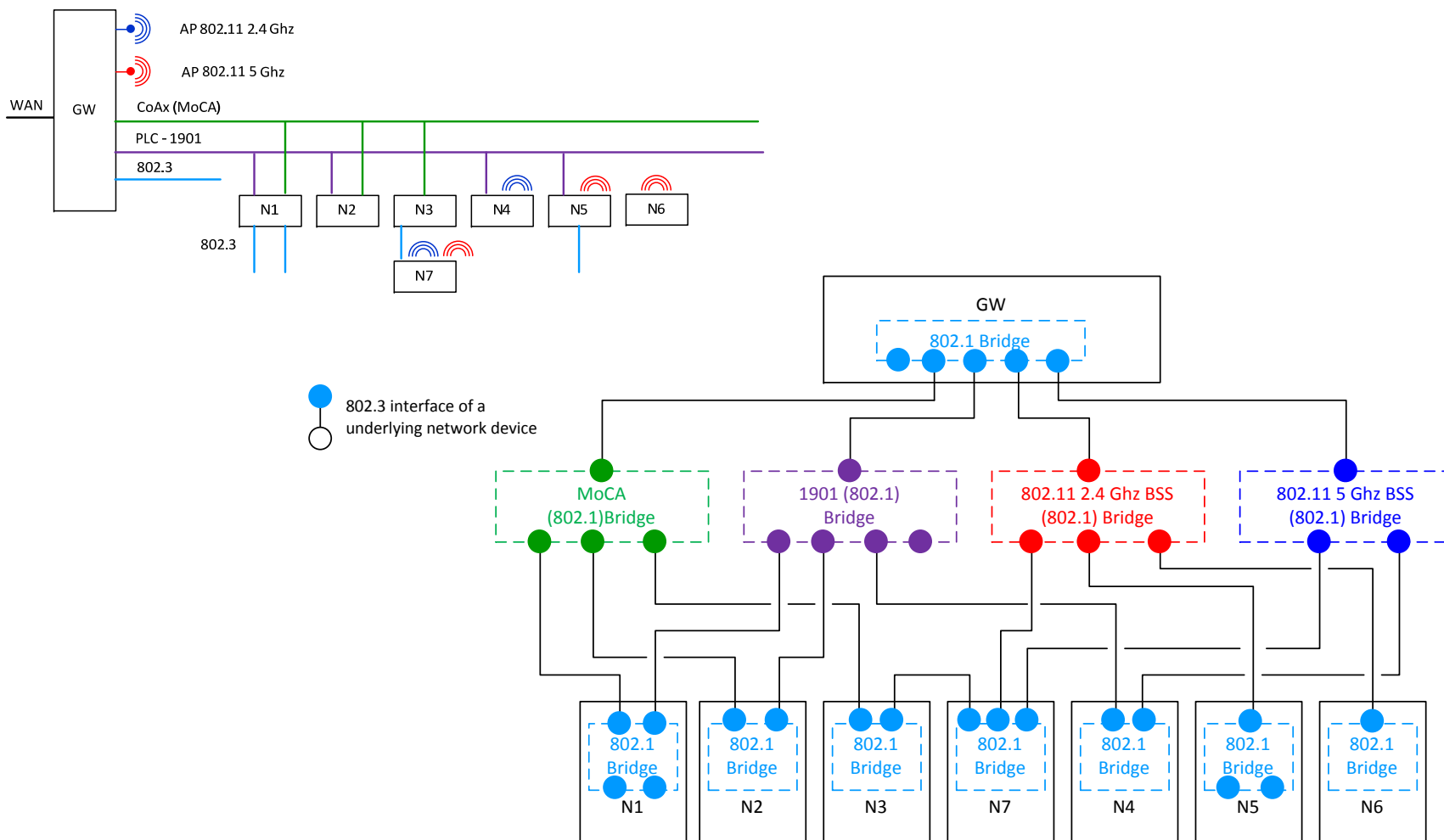

# GW Centric Data Planes

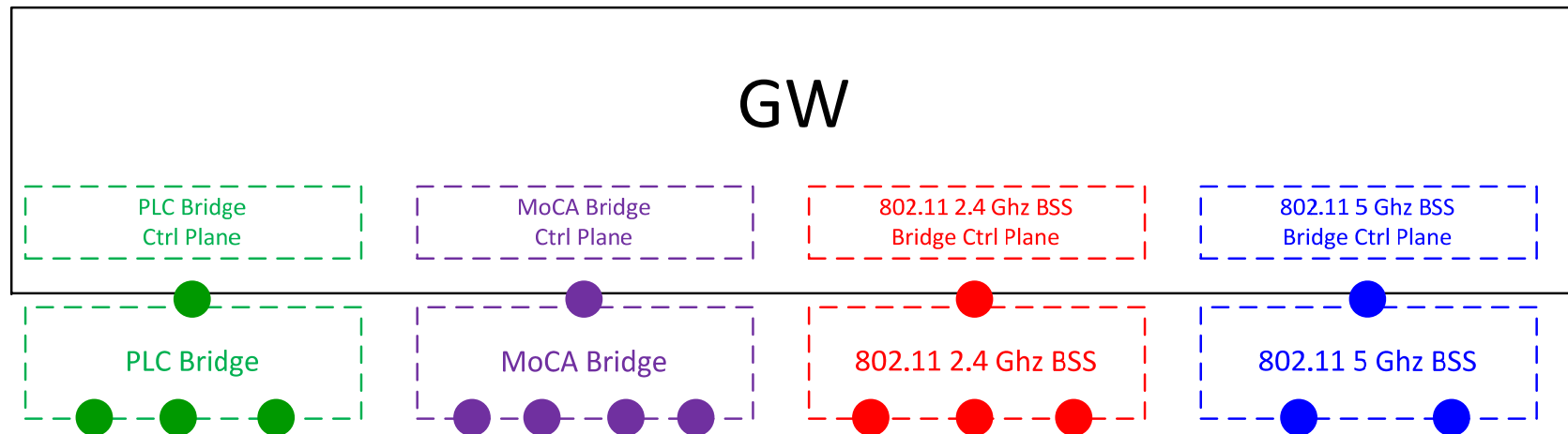

- GW is the Designated Node for each CSN:  
CSN Bridge Data Planes are co-hosted into the GW

# GW Centric Data Plane



- For Network Control Protocols (such RSTP)
  - each CSN bridge runs its own control plane
  - same 802.1 standard protocol entity instantiated per CSN bridge

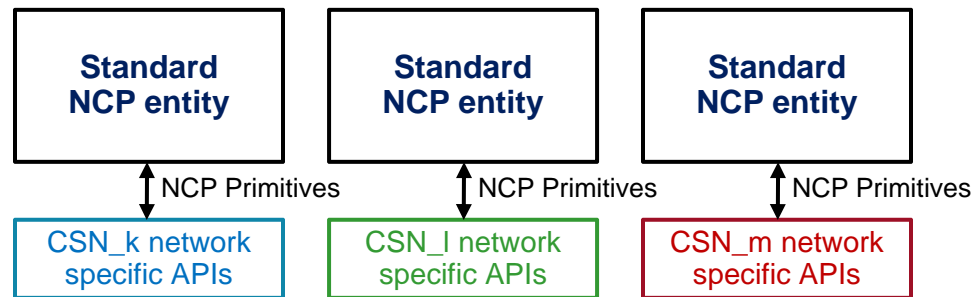

- For Network Service Protocols (such MSRP)
  - a single control plane for all the CSNs
  - NSP primitives mapped to each CSN specific APIs

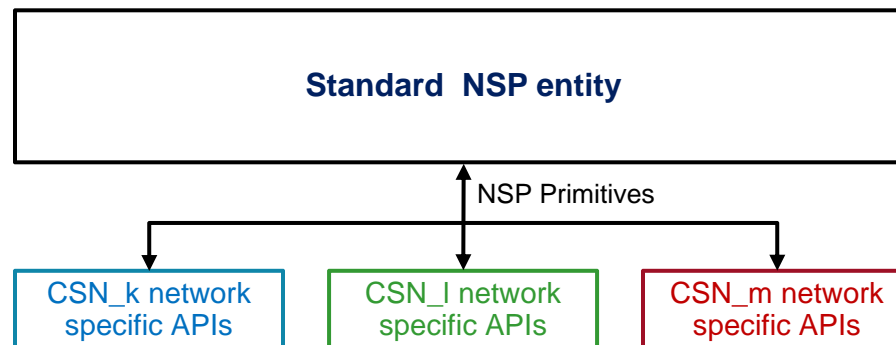

- Optimized case for IS-IS:
  - Single IS-IS Database with multiple Topologies
    - Immediate topology change “propagation”
    - Immediate coherency
    - No traffic overhead between bridges
    - Optimized resource

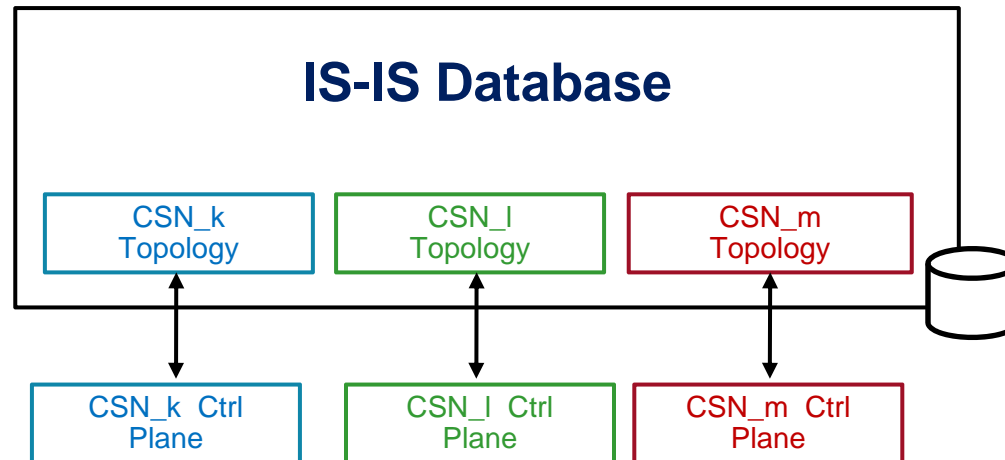

# Thank You

[philippe@broadcom.com](mailto:philippe@broadcom.com)

