

# 802.1Q Forwarding PTP messages in an IEEE Transparent Clock

Considerations in response to liaison from Q13/15

John Messenger, Anthony Magee, Nir Laufer, November 2012

v03

# Background



- ITU-T Q13/15 is developing a Telecom profile of IEEE Std 1588-2008.
- The exact meaning of certain parts of IEEE Std 1588 may not be clear to a reader used to the style of IEEE 802.1 protocol standards.
- The IEEE 1588-2008 Interpretation Committee has issued an [interpretation response](#) part of which relates to the treatment of the source protocol address of PTP messages.
- Q13 is seeking guidance from 802.1 as to whether certain proposed behaviours in Q13's Telecom profile of IEEE Std 1588 are permitted by 802.1Q-2011. The questions relate to a device styled as an "IEEE 1588-2008 Transparent Clock layer 2 bridge".
- We don't have one of those.

# Encapsulations



- Q13 is interested in three IEEE 1588 encapsulations
  - Directly in an Ethernet frame (IEEE 1588 Annex F)
  - In a UDP over IPv4 packet (IEEE 1588 Annex D) carried over Ethernet
  - In a UDP over IPv6 packet (IEEE 1588 Annex E) carried over Ethernet
- These will be considered separately
- The UDP/IPv4/Ethernet encapsulation is widely used, but the direct Ethernet encapsulation is now being specified in new IEEE 1588 profiles.
- Although Annexes D and F of IEEE 1588 specify multicast operation, both unicast and multicast IPv4 and Ethernet destination addresses will be routinely used. Unicast is widely used today.
- The following slides attempt to describe how an 802.1Q-2011 VLAN Bridge would treat the different encapsulations.

# UDP over IPv4 over Ethernet



- Multicast IPv4 destination address
  - This would map to an 802 multicast DA (RFC 1112)
  - An 802.1Q VLAN Bridge would forward the frame unchanged.
- Unicast IPv4 destination address
  - This would map to an 802 unicast DA (using ARP)
  - An 802.1Q VLAN Bridge would forward the frame unchanged.
- When using these encapsulations, an “IEEE 1588-2008 Transparent Clock layer 2 bridge” which altered the packet as described in IEEE 1588 would not be a conformant 802.1Q VLAN Bridge.

# Directly over Ethernet



- IEEE 1588 specifies an Ethertype for this encapsulation: 88F7.
- Multicast 802 DA as described in IEEE 1588 Annex F
  - Two group addresses are specified, for general messages and for peer-delay mechanism messages, but a Profile may use either address for all messages if it wants to.
  - 01-1B-19-00-00-00 – a general group address
    - An 802.1Q VLAN Bridge would forward the frame unchanged.
  - 01-80-C2-00-00-0E – Individual LAN Scope group address
    - An 802.1Q VLAN Bridge would drop the frame.
- Unicast 802 DA (not described in IEEE 1588 Annex F)
  - An 802.1Q VLAN Bridge would forward the frame unchanged.
- When using these encapsulations, an “IEEE 1588-2008 Transparent Clock layer 2 bridge” which altered the packet as described in IEEE 1588 would not be a conformant 802.1Q VLAN Bridge.
  - See later slides for details on using higher-layer entities to enhance this behaviour.

# Liaison received from Q13



- Uploaded as <http://www.ieee802.org/1/files/public/docs2012/liaison-itut-ols-443-plen-744-wp3-annex-q-1012.docx>

# Question 0



- “Questions have been raised concerning an IEEE 1588-2008 Transparent Clock layer 2 bridge modifying the CorrectionField of Ethernet transported PTP frames without changing the Ethernet source MAC address. The question is if this operation is permitted by IEEE 802.1Q.”
- 802.1Q does not specify an “IEEE 1588-2008 Transparent Clock layer 2 bridge” and so is silent on this topic. 802.1Q neither permits nor prohibits this behaviour.
- 802.1Q Bridges do not interpret header fields following the Ethertypes for IPv4 or IPv6, nor for PTP over Ethernet.
- It seems unlikely that a “IEEE 1588-2008 Transparent Clock layer 2 bridge” would interpret header fields following the Ethertypes for IPv4 or IPv6.

# Question 1



- “If the PTP layer of the TC is above the MAC relay and the higher-layer entities of the bridge, does IEEE 802.1Q [1] require that the source MAC address of a frame sent by the TC that contains a PTP message be the MAC address of the port of the TC on which the frame is sent?
  - [The case where the PTP layer of the TC is above the MAC relay and the higher-layer entities of the bridge is shown in Figure 1.]”
- 802.1Q states non-normatively that the source address of a frame transmitted by a higher-layer entity attached to one port of a bridge “is” the MAC address of that port. Transmitting a frame with any other SA can disrupt the learning and filtering mechanisms of 802.1Q bridges, resulting in a loss of connectivity.
- Constructing an “IEEE 1588-2008 Transparent Clock layer 2 bridge” using higher-layer entities attached to the ports of a VLAN Bridge is discussed in a later slide.



# Question 2



- “Is the source MAC address of this frame allowed to be the MAC address of the port of the upstream boundary clock or ordinary clock where the timing information originates?
  - [The case where the PTP layer of the TC is above the MAC relay and the higher-layer entities of the bridge is shown in Figure 1.]”
- Although 802.1Q does not normatively require that the SA of a frame transmitted by a higher-layer entity be the MAC address of the transmitting port, answer 1 describes the dangers of this.

# Question 3



- “Would it be compliant to forward a frame thorough the normal MAC relay function but update the CorrectionField and the FCS without any other modification of the frame?
  - [In this case, the PTP processing done by the TC (including the updating of the correctionField) is done in the MAC relay, rather than in a PTP layer that is above the Higher Layer Entities.]”
- No, this would not be compliant because 802.1Q does not specify such behaviour.
- However such a modification, if made in the relay function, is not inconsistent with the 802.1Q architecture (see later slide)

# Question 4



- “Does the IEEE 802.1 Working Group have an alternate proposal or possibilities that would be compliant with IEEE 802 specifications, such as MAC relay service function, that may support IEEE 1588-2008 Transparent Clock functionality, and whether such proposal relates to current or planned specifications or specification revisions?”
- We could talk about that. (I’ve been learning from Norm.)
  - Can you construct an “IEEE 1588-2008 Transparent Clock layer 2 bridge” using a VLAN Bridge and a couple of higher-layer entities which talk to each other?
  - Do we want to specify, in an amendment to 802.1Q, behaviour consistent with the intentions of IEEE 1588 Annex F (Ethernet encapsulation)?

# Making one using higher-layer entities

- Use the IEEE 1588 Annex F encapsulation (i.e. not IP)
- Use Multicast addressing
  - Install a static filtering entry for the 01-1B-19-00-00-00 address
- Receive the PTP frame in a higher-layer entity and transmit on “other ports”.
  - Modify the frame fields per IEEE 1588 on a port-by-port basis for transmission
  - There are two choices for SA:
    - The original SA
    - An SA belonging to the bridge (e.g., transmitting port’s SA or Bridge Brain SA)
- Have you caused problems with learning or duplication
  - In this bridge?
  - In other bridges?

# Problems with higher-layer entities using non-local source addresses



- An 802.1Q VLAN bridge uses the mechanism in 8.5.1 to connect the higher layer entities and MAC relay to the attached LAN.

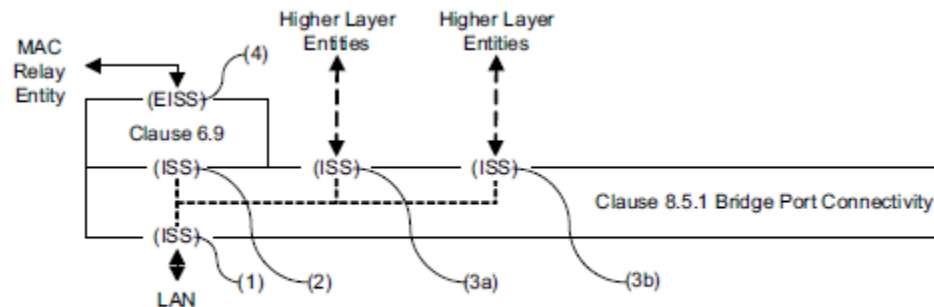

Figure 8-8—Bridge Port Transmit and Receive

- The transmitted frame's source address will be learnt on the outgoing port.
- A subsequent frame received on this port with that destination address will be dropped, resulting in connectivity loss.

# Problems with higher-layer entities bypassing the MAC Relay



- The higher-layer entities aren't directly aware of the port states of the bridge, and might therefore transmit the modified frame on a port blocked by RSTP.
- This could cause other bridges to learn the SA of the re-transmitted frame on inappropriate ports.
- It could also cause multiple, possibly differently modified copies of the frame being received at the destination.

# Does 802.1 want to tackle this issue?



- Reasons we might want to:
  - IEEE 1588 is being adopted by industry widely
  - Difficulty of interpreting how to use IEEE 1588 in bridged networks is holding back some deployment models (Transparent Clock).
  - Ethernet encapsulation, for cases where the frames need to be modified en-route, seems more sensible than layer-3 encapsulation, because the fields needing modification are not buried in an IP header.
  - Non-standard implementations are being deployed already, and a standard would better ensure interoperability.
- Although 802.1 did not create the problem, it could be part of the solution

# What might an 802.1Q solution look like?



- Architecture:
  - Intercept and modify selected frames
    - Ethertype
    - Addressing restriction?
  - Use a similar architecture to 802.1ag for frame processing
  - Refer to IEEE 1588 for protocol field updating
  - Refer to 802.3bf for frame timing information?
  - Transmit frames using a Linktrace Output Multiplexer
- Advantages:
  - Avoidance of learning issues
  - Avoidance of duplication issues
  - Ensure consistency with 802.1Q model





Thank You

[JMessenger@advaoptical.com](mailto:JMessenger@advaoptical.com)