

**IEEE 802.11**  
**Wireless Access Method and Physical Specification**

---

Title: **FH Interoperability Addition to Harris HS PHY Proposal**

Date: March 9, 1998

Author: Dean Kawaguchi

Symbol Technologies, Inc.  
2145 Hamilton Ave  
San Jose, CA. 95125  
Telephone: (408)369-2629  
FAX: (408)369-2737  
email: deank@psd.symbol.com

**Introduction**

Backward interoperability with 1/2 Mbps DS PHY is provided for within the Harris High Speed (HS) PHY proposal. Backward interoperability to 1/2 Mbps DS is important for maximum range, robustness in severe multipath, minimum collisions (CCA), variety of cost vs performance tradeoff options, and preservation of customer investments.

This submission proposes an FH PHY backward interoperability mode as an option for the Harris 5.5/11 Mbps HS PHY proposal. This add on proposal does not modify the basic modulation format, but it assumes the addition of the HS preamble that Harris discussed in previous meetings. This proposal basically wraps around the Harris proposal to add a rate scaling path from the 1/2 Mbps FH up to the 11 Mbps DS signal and back. Two fundamental elements required for FH interoperability are

- 1) hopping of the wideband DS signal synchronized to the FH hop sequences and
- 2) using the FH preamble in front of the HS preamble and data.

It is important to note that the resulting system is not a hybrid system with regard to FCC rules, but a dual mode radio: an FH mode and a DS mode that also hops.

Why is FH interoperability important? The same reasons that applied to the DS PHY of range, multipath, CCA, cost vs performance options, and preserving investments apply here as well. However, the most important reason - unique to FH - is reliability, or survivability, in interference limited environments that is likely in the unlicensed ISM band in which this HS

PHY standard will operate. Hopping of the wideband HS signal will provide a level of protection against a variety of fixed frequency interference. As a last line of defense, backing down to 1/2 Mbps FH with 79 1 MHz channels will provide the best chance of operating through interference.

Symbol's experiences in the 900 MHz band has convinced us that a fixed frequency system will fail in the presence of interference leaving little recourse for the customer. Changing channels is slow and often does not work since the interferer may use channels randomly, as cordless phones do. Our proprietary format 900 MHz DS system that we have been selling since 1990 has evolved into a hopping DS system to provide reliable connection in the presence of interference. This was possible since it was a proprietary format, but standards are much more difficult to evolve in this way. The 2.4 GHz band may eventually be worse than the 900 MHz band since it is the only unlicensed band available worldwide. Also, non-802.11 systems in this band are already and will continue to be a significant portion of the usage of this band.

It is well known that the most efficient use of the band would be achieved by frequency planning in a cellular arrangement. However, that requires control of the band which cannot be guaranteed in the unlicensed ISM band. Equally well known is that you can put more overlapping BSS's (essentially non interfering) using the FH format than the wideband DS format. The FH interoperability mode achieves a compromise of the best of both formats, achieving both 11 Mbps peak data rates and falling back to 1 MHz FH for maximum reliability in dense environments. It trades off the efficiency of the cell planning approach for the reliability of frequency hopping and the flexibility of scaling down to a 1 MHz wide FH signal.

## **Proposal Overview**

### **Hop Sequences, Synchronization, and Frequency Plan**

The hopping of the HS PHY will be defined and synchronized using the mechanisms contained in the existing 802.11 standard for the FH PHY. The particular 1 MHz channel selected will be associated with a HS PHY channel center frequency.

There are 5 HS PHY channels shown in Figure 1 which are about 22 MHz null to null. The HS channels are partially overlapped with a channel spacing of 15 MHz. The HS channels use a subset of the center frequencies defined in the DS PHY section. There are a number of 1 MHz FH channels assigned to each HS channel. When the hop sequence determines a particular 1 MHz channel is next, the HS channel that has its center frequency closest to the selected 1 MHz channel is used to transmit and receive HS data. For example, with 2419 MHz selected as the 1 MHz channel, the HS channel selected would be centered at 2412 MHz.

The 1 MHz FH channels are, in general, offset in center frequency by up to +/- 7 MHz. The channels at each end of the band must cover to the edge of the band. Since the FH channels are from 2402 to 2480 MHz, the bottom channel must tune to -10 MHz from the HS center frequency of 2412, and the top channel must tune to +8 MHz from the HS center frequency of 2472. However, power and sensitivity would be reduced by several dB at the +/-10 MHz offset due to filter rejection.

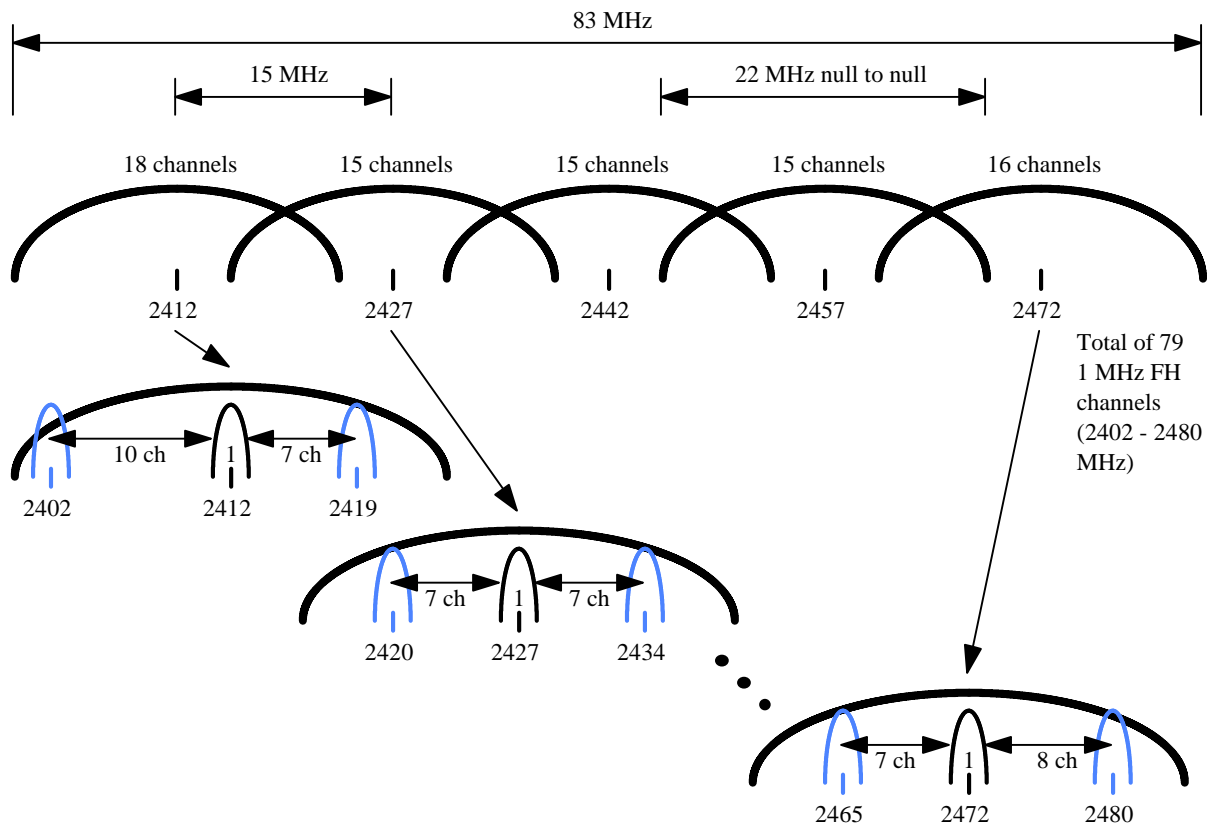

Figure 1. Frequency Plan of HS PHY and FH PHY channels

Several options that are not part of this proposal but could be considered is that of adding new FH hop sequences which improves performance in the mixed HS and FH environments.

- 1) By hopping a minimum of 15 MHz instead of 6 would guarantee that the next hop will also hop the wideband channel.
- 2a) Reducing the number of channels to 77 by chopping off the bottom 2 channels would limit the frequency offset of the 1 MHz FH channel to +/- 8 MHz from the HS channel center. The resulting FH channels would use 2404 to 2480 MHz.
- 2b) The minimum number of FH channels specified by the FCC is 75. Chopping off 1 channel on each end of the band from (2a) would limit the FH to HS channel offsets to +/- 7 MHz. The resulting 75 FH channels would use 2405 to 2479 MHz.

Backward interoperability with the DS PHY necessitates turning off the hopping feature since hopping is not part of the DS PHY in the existing standard. Turning off the HS hopping of course loses the interference mitigation capabilities of the hopping.

**Rate Scaling with the FH Backward Interoperability Header**

Rate scaling using an FH 1 Mbps preamble and header would provide for 1/2 Mbps FH operation when range, multipath, or backwards interoperability required. Units that are operating in 1/2 Mbps FH mode only will be able to see the length of the frame and defer for the duration of the frame. The frame format of the FH mode when operating completely at 1/2 Mbps is unchanged as defined in the existing FH PHY. The frame format when scaling up to 5.5 or 11 Mbps is shown in Figure 2. The FH interoperability frame is composed of:

- 1) 96  $\mu$ sec 1 Mbps FH preamble, which contains an 80  $\mu$ sec sync pattern and 16  $\mu$ sec start frame delimiter
- 2) 32  $\mu$ sec 1 Mbps FH PLCP header, which contains a 12 bit PLCPPDU length word and 4 bit PLCP signaling field
- 3) 8  $\mu$ sec gap for separating FH from HS DS packets
- 4) HS preamble and PLCP header as defined by the Harris proposal
- 5) 5.5 or 11 Mbps data

1 Mbps FH Preamble	1 Mbps FH PLCP Header	Gap	HS Preamble & Header	5.5/11 Mbps Data
96 usec	32 usec	8 usec	~50 usec	Variable

Figure 2. FH Backward Interoperability Frame Format

Figure 3 shows the DS backward interoperability frame format for comparison with the FH. The length of the packets in either case is about the same.

1 Mbps DS Preamble	1 Mbps DS PLCP Header	5.5/11 Mbps Data
144 usec	48 usec	Variable

Figure 3. DS Backward Interoperability Frame Format

The 4 bit FH PLCP Signaling Field will be modified to utilize the reserved bit b0 to expand the data rates from 8 to 16 different values. The data rates will include the rates shown in Table 1.

b0	b1	b2	b3	Indicated rate
0	X	X	X	Rates 1 - 4.5 Mbps per existing text
1	0	0	0	5.5 Mbps
1	0	0	1	11 Mbps
1	0	1	0	16.5 Mbps
1	0	1	1	22 Mbps
1	1	0	0	27.5 Mbps
1	1	0	1	33 Mbps
1	1	1	0	38.5 Mbps
1	1	1	1	44 Mbps

Table 1. Data Rates in Modified PLCP Signaling Field

To maintain hopping without the FH PHY backward interoperability header, the base rate of the BSS would be set at the high speed rate and thus all management packets sent at the higher rate. However, to retain the 1/2 Mbps FH rate scaling capability, the 1 Mbps FH header must be added on whenever the rate scaling feature is needed.

### 1/11 Mbps Cross Interference and CCA

If there is only one BSS, there will not be excessive collisions with the mixed FH and HS operation. When there are more than one BSS, there may be 1/2 Mbps FH traffic at other channels inside the wideband HS channel. The probability of interference of this mixed mode case is in general better than the probability of the interference between two hopping HS BSS's because the adjacent HS channel is less of a problem. There are implementation options available to perform CCA on all channels within the wideband HS channel. These vary from simple RSSI techniques to more complex algorithms implemented mainly at the cost of additional gates.

### Rate Switching Algorithms

The algorithms and triggers for rate switching between the rates in the released standard are not specified by 802.11. This will be the same in the case of 1/2 Mbps FH to HS operation.

### Implementation Considerations

Implementation issues need to be addressed in the standards process to validate the practicality of the proposal. The following discussion summarizes an implementation currently in a joint

development between Harris and Symbol. The resulting chip set, when released, will be widely available from Harris to all interested companies at fair and reasonable terms.

The discussion here assumes primarily digital implementation of the FH processing. The reason is that most of the non-digital functions and components are common with that needed for HS processing.

There are two modes of FH processing needed to achieve the full benefits of the FH interoperability. Wideband mode allows full interoperability with both HS and FH packets. However, selectivity will be less than specified in the FH section. In narrowband mode, FH operation with maximum selectivity performance ensures best possible performance in interference limited environments. Wideband mode uses the same bandwidths as the HS signal processing, whereas narrowband mode uses a 1 MHz SAW to achieve the selectivity of an FH compliant device.

Figure 4 shows the block diagram of the transmitter using I/Q processing to generate the GFSK signal and offset the signal up to +/- 10 MHz from the wideband center. Figure 5 shows the corresponding signal spectrum that results including both desired and undesired components.

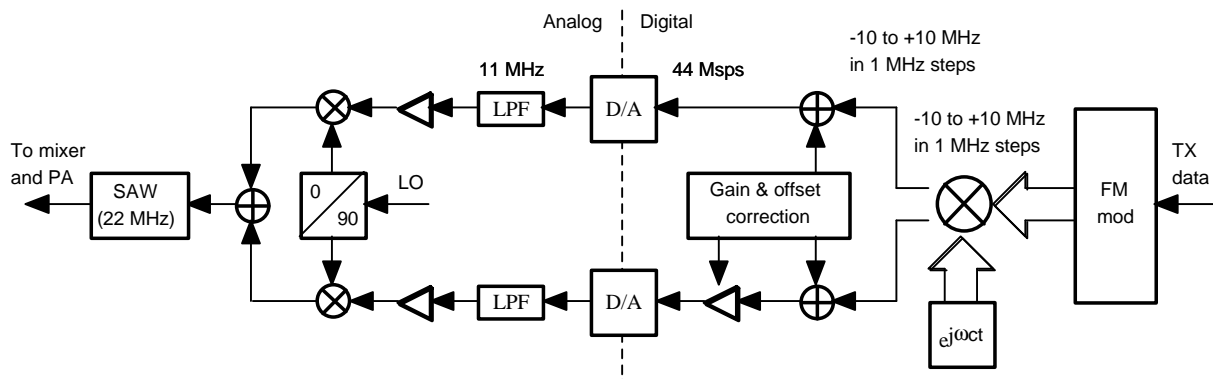

Figure 4. Transmitter Block Diagram

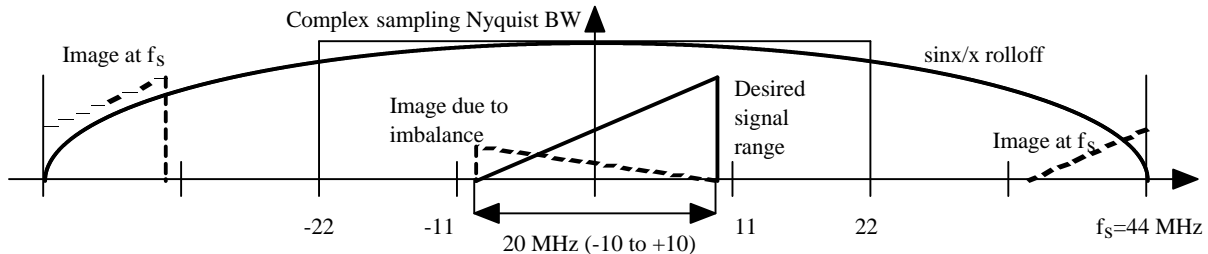

Figure 5. Transmit Signal Spectrum

Figure 6 shows the block diagram of the receiver, again using the I/Q processing to recover the GFSK signal which is offset up to +/- 10 MHz from the wideband center. Figure 7 shows the corresponding signal spectrum that results including both desired and undesired components.

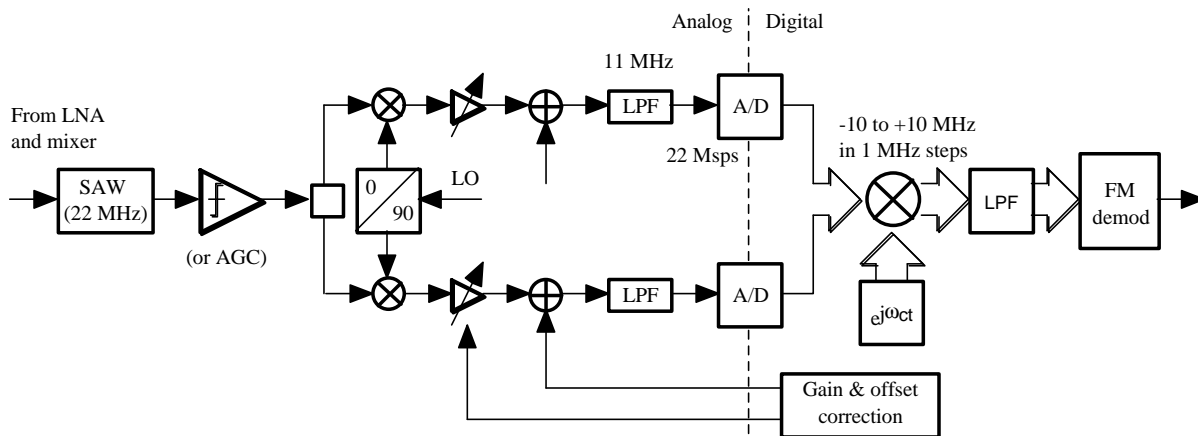

Figure 6. Receiver Block Diagram

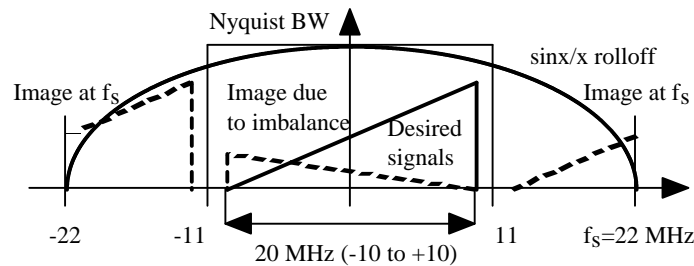

Figure 7. Receive Signal Spectrum

The requirements, problems, and tradeoffs encountered in implementation have brought up some discussion of changes to the proposal to make implementation simpler and more cost effective.

One example is the necessity to have a high degree of phase and amplitude balance and small DC offsets. Phase and amplitude imbalance in the transmitter causes images on the other side of DC that will be unattenuated in the wideband mode. DC offsets in the transmitter causes unmodulated carrier components which would also be unattenuated in the wideband mode. In the receiver, phase and amplitude imbalance distorts the signal slightly and reduces the selectivity which would be achievable otherwise.

One way to achieve receiver balancing is to estimate and correct the various imbalances and offsets during the preamble of an actual receive signal. A problem that arises is that when the FH channel is at DC, or the same center frequency as the HS channel, the signal during the preamble

will vary in I/Q space about  $60^\circ$  on the unit circle. This makes it difficult to separate the I and Q imbalance and offset components.

Three options to resolve this problem are:

- 1) Measure and correct between regular packets
- 2) Offset LO tuning and process signal at a frequency offset to guarantee excursions around the full unit circles within a short period.
- 3) Select a different center frequency for the wideband signal, i.e., the channel center frequency 5 MHz away when the signal falls at the center of a HS channel. This will increase the number of channels to 13 overlapping channels.

The first two options only affect the implementation, whereas the third one changes the protocol to simplify the implementation. In this particular case, the degree of change to the protocol is probably not warranted.