IEEE P802.11
Wireless LANs

**High Speed Direct Sequence Spread Spectrum Physical Layer
Specification for the 2.4 GHz ISM Band**

Date: May, 1998

Author: Carl Andren
Harris Semiconductor
Address
Phone:
Fax:
e-Mail:

Abstract**High Speed Direct Sequence Spread Spectrum Physical Layer Specification
for the 2.4 GHz ISM Band****1.1 Introduction**

This clause describes the physical layer for the High speed Direct Sequence Spread Spectrum (HSDSSS) system. The Radio Frequency LAN system is initially aimed for the 2.4 GHz ISM band as provided in the USA according to Document FCC 15.247, in Europe by ETS 300-328 and other countries according to clause 15.4.6.2.

The DSSS system provides a wireless LAN with 1 Mbit/s, 2 Mbit/s, 5.5 Mbit/s, and 11 Mbit/s data payload communication capabilities. Only the 5.5 Mbit/s and 11 Mbit/s modes are covered by this section. The HSDSSS system uses Binary M-ary Bi-Orthogonal Keying and Quadrature M-ary Bi-Orthogonal Keying for the 5.5 and 11 Mbit/s data rates respectively.

1.1.1 Scope

This clause describes the physical layer services provided to the 802.11 wireless LAN MAC by the 2.4 GHz Direct Sequence Spread Spectrum system. The DSSS PHY layer consists of two protocol functions:

- a) A physical layer convergence function which adapts the capabilities of the physical medium dependent system to the Physical Layer service. This function shall be supported by the Physical Layer Convergence Procedure (PLCP) which defines a method of mapping the 802.11 MAC sublayer Protocol Data Units (MPDU) into a framing format suitable for sending and receiving user data and management information between two or more stations using the associated physical medium dependent system.
- b) A Physical Medium Dependent (PMD) system whose function defines the characteristics and method of transmitting and receiving data through a wireless medium between two or more stations each using the DSSS system.

1.1.2 DSSS Physical Layer Functions

The 2.4 GHz DSSS PHY architecture is depicted in the reference model shown in Figure 11. The DSSS physical layer contains three functional entities: the physical medium dependent function, the physical layer convergence function, and the layer management function. Each of these functions is described in detail in the following subclauses.

The DSSS Physical Layer service shall be provided to the Medium Access Control through the physical layer service primitives described in clause 12.

1.1.2.1 Physical Layer Convergence Procedure Sublayer

In order to allow the 802.11 MAC to operate with minimum dependence on the PMD sublayer, a physical layer convergence sublayer is defined. This function simplifies the physical layer service interface to the 802.11 MAC services.

1.1.2.2 Physical Medium Dependent Sublayer

The physical medium dependent sublayer provides a means to send and receive data between two or more stations. This clause is concerned with the 2.4 GHz ISM bands using Direct Sequence modulation.

1.1.2.3 Physical Layer Management Entity (LME)

The Physical LME performs management of the local Physical Layer Functions in conjunction with the MAC Management entity.

1.1.3 Service Specification Method and Notation

The models represented by figures and state diagrams are intended to be illustrations of functions provided. It is important to distinguish between a model and a real implementation. The models are optimized for simplicity and clarity of presentation, the actual method of implementation is left to the discretion of the 802.11 DSSS PHY compliant developer.

The service of a layer or sublayer is a set of capabilities that it offers to a user in the next higher layer (or sublayer). Abstract services are specified here by describing the service primitives and parameters that characterize each service. This definition is independent of any particular implementation.

1.2 DSSS Physical Layer Convergence Procedure Sublayer

1.2.1 Introduction

1. This clause provides a convergence procedure in which MPDUs are converted to and from PPDU's. During transmission, the MPDU shall be prepended with a PLCP preamble and header to create the PPDU. At the receiver, the PLCP preamble and header are processed to aid in demodulation and delivery of the MPDU.

1.2.2 Physical Layer Convergence Procedure Frame Format

Three preamble and header configurations are used to secure various degrees of interoperability with the FH and DS PHY implementations described in sections 14 and 15. These types are:

1. A DS interoperable preamble and header that is identical to the DS PHY preamble and header described in section 15. This would be directly followed by a high rate MPDU.
2. A high rate only (HRO) DS PHY preamble and header that is not interoperable with either the DS or FH PHYs. This is used for maximum throughput in situations where interoperability is not desired or needed.
3. **An FH interoperable preamble and header that is composed of the FH preamble and header followed by the HRO preamble and header described above and the high rate MPDU. This allows for a FH interoperability mode where the rate field of the FH header selects whether or not the header will be followed by 1 or 2 Mbit/s FH signals or the High Rate signals.**

1.2.2.1 DS Interoperability Frame Format (type 1)

Figure 88 shows the format for the PPDU including the Type 1 DSSS PLCP preamble, the DSSS PLCP header and the MPDU. The PLCP preamble contains the following fields: synchronization (SYNC) and Start Frame Delimiter (SFD). The PLCP header contains the following fields: 802.11 signaling (SIGNAL), 802.11 service(SERVICE), length(LENGTH), and CCITT CRC-16. Each of these fields are described in detail in clause 1.2.3.

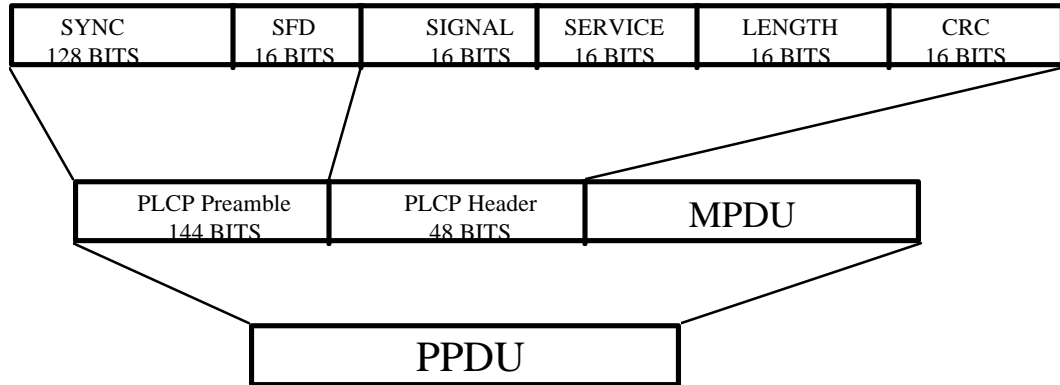

Figure 88, PLCP Frame Format

1.2.2.2 High Speed Only frame Format (type 2)

Figure 89 shows the HRO format for the PPDU including the Type 2 DSSS PLCP preamble, the DSSS PLCP header and the MPDU. The PLCP preamble contains the following fields: synchronization (SYNC) and Start Frame Delimiter (SFD). The PLCP header contains the following fields: length(LENGTH), signaling (SIGNAL), and CCITT CRC-16. Each of these fields are described in detail in clause 1.2.3.

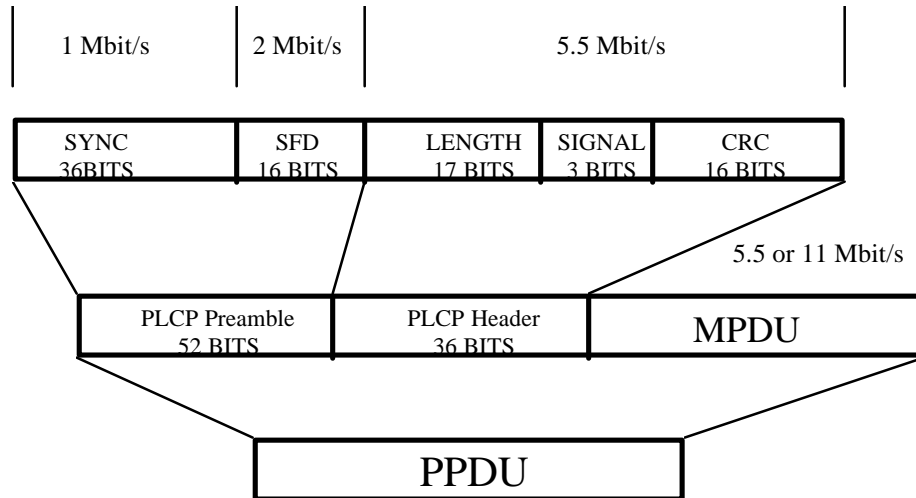

Figure 89, Short, High Rate only, PLCP Frame Format

1.2.2.3 FH Interoperability Frame Format (type 3)

Figure 90 shows the Frequency Hopping interoperability format for the PPDU. This includes the standard FH PLCP preamble, the FH PLCP header, an 8 microsecond gap, and the type HRO preamble and header and the MPDU. The FH interoperability mode uses the FH preamble and header to establish the channel the signal will be radiated on and the rate it will use. When in this mode, the HR DS channel will be chosen as the closest DS channel from the set of: 1, 3, 5, 7, 9, and 11 (plus 13 in Europe). The receiver IF which will process the HR DSSS data must be wide enough in bandwidth to encompass the FH preamble. When operating on the lowest TBD or the highest TBD FH channels, the HR DS will not be used and all FH transmissions will occur at the 1 or 2 Mbit/s rates. These channels are too far away from the available DS channels to be processed in the IF bandwidth.

The PLCP preamble contains the following fields: synchronization (SYNC) and Start Frame Delimiter (SFD). The PLCP header contains the following fields: PSDU length word (LENGTH), PLCP signaling field (SIGNAL), and Header Error Check (CCITT CRC-16). Each of these fields are described in detail in clause 1.2.3.

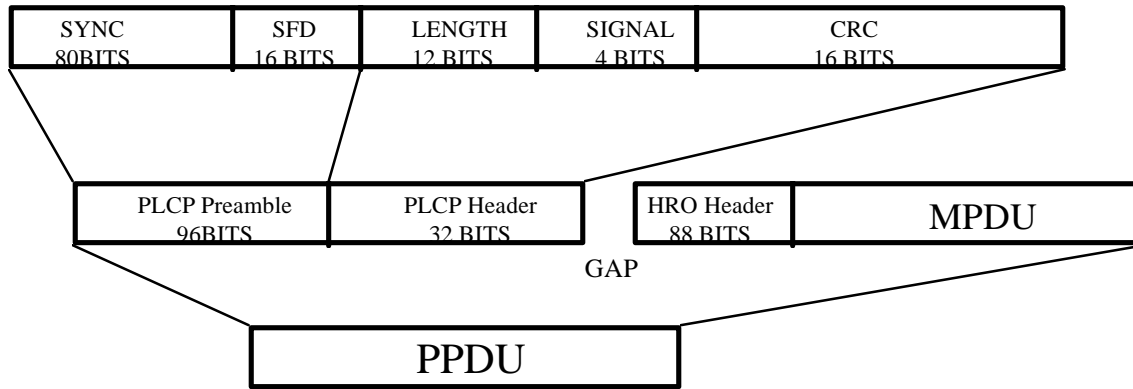

Figure 90, FH interoperable PLCP Frame Format

1.2.3 PLCP Field Definitions

The entire PLCP preamble and header shall be transmitted using the 1 Mbit/s DBPSK modulation described in clause 15.4.7. All transmitted bits shall be scrambled using the feedthrough scrambler described in clause 15.2.4.

1.2.3.1 PLCP Synchronization (SYNC)

This field shall be provided so that the receiver can perform the necessary operations for synchronization. The synchronization field shall consist of one of the following:

1. 128 bits of scrambled 1 bits for type 1
2. A random data pattern of 36 bits for type 2. The pattern will be: TBDh.
3. 80 bits of alternating zeros and ones starting with zero and ending with one for type 3

1.2.3.2 PLCP Start Frame Delimiter (SFD)

The Start Frame Delimiter shall be provided to indicate the start of PHY dependent parameters within the PLCP preamble. The SFD shall be a 16 bit field which is one of the following:

1. F3A0h (MSB to LSB) for type 1. The LSB shall be transmitted first in time. The SFD and header are scrambled as described later.
2. F3A0h (MSB to LSB) for type 2. The LSB shall be transmitted first in time. It will not be scrambled like the type 1.
3. 0CBDh (MSB to LSB) for type 3. The LSB shall be transmitted first in time. This SFD is not scrambled.

1.2.3.3 PLCP 802.11 Signal Field (SIGNAL)

For type 1 headers, the 8 bit 802.11 signal field indicates to the PHY the modulation which shall be used for transmission (and reception) of the MPDU. The data rate shall be equal to the Signal Field value multiplied by 100Kbit/s. The DSSS PHY supports four modulation services given by the following 8 bit words, where the LSB shall be transmitted first in time:

- a) 0Ah (MSB to LSB) for 1 Mbit/s DBPSK
- b) 14h (MSB to LSB) for 2 Mbit/s DQPSK

- c) 37h (MSB to LSB) for 5.5 Mbit/s BMBOK
- d) 6Eh (MSB to LSB) for 11 Mbit/s QMBOK

The first two rates are mandatory . The DSSS PHY rate change capability is described in clause 1.2.5. This field shall be protected by the CCITT CRC-16 frame check sequence described in clause 1.2.3.6.

For type 2 headers, the Signal field will consist of 3 bits. Two are spare and one selects 5.5 vs 11.

For Type 3 headers, the signal field is 4 bits where the 1st selects the high rate mode and the remaining 3 bits select a low rate mode of 1.0 to 4.5 Mbit/s in 0.5 Mbits/s increments. The Signal field is transmitted with the high rate bit first. When the high rate bit is set, the rest are all 1s to indicate to a standard station that this is an unsupported rate.

1.2.3.4 PLCP 802.11 Service Field (SERVICE)

The packet length needs to be reported in terms of 0.5 us increments, so one bit of the previously reserved 8 bit Service field shall be used for this purpose. The LSB shall be transmitted first in time. This field shall be protected by the CCITT CRC-16 frame check sequence described in clause 15.2.3.6. This field is only in the type 1 header.

1.2.3.5 PLCP Length Field (LENGTH)

For the type 1 header, the PLCP length field shall be an unsigned 16 bit integer which indicates the number of microseconds (16 to $2^{16}-1$ as defined by aMPDUMaxLngth) required to transmit the MPDU. The transmitted value shall be determined from the LENGTH parameter in the TXVECTOR issued with the PHYTXSTART.request primitive described in clause 12.3.5.4. The length field provided in the TXVECTOR is in bytes and is converted to microseconds for inclusion in the PLCP LENGTH field. The LSB (least significant bit) shall be transmitted first in time. This field shall be protected by the CCITT CRC-16 frame check sequence described in clause 1.2.3.6.

For the type 2 header, the length field shall be an unsigned 17 bit integer which indicates the number of microseconds (16 to $2^{16}-1$ as defined by aMPDUMaxLngth) required to transmit the MPDU. The transmitted value shall be determined from the LENGTH parameter in the TXVECTOR issued with the PHYTXSTART.request primitive described in clause 12.3.5.4. The length field provided in the TXVECTOR is in bytes and is converted to microseconds for inclusion in the PLCP LENGTH field. The LSB (least significant bit) shall be transmitted first in time. This field shall be protected by the CCITT CRC-16 frame check sequence described in clause 1.2.3.6.

For the type 3 header, the PLCP length field shall be an unsigned 12 bit integer which indicates the number of octets in the PSDU as defined by aMPDUMaxLngth) required to transmit the MPDU. The transmitted value shall be determined from the LENGTH parameter in the TXVECTOR issued with the PHYTXSTART.request primitive described in clause 12.3.5.4. The length field provided in the TXVECTOR is in bytes. The Length is used by the receiving STA, in combination with the 32/33 coding algorithm specified in section 14.3.2.3 to determine the last bit in the packet. The LSB (least significant bit) shall be transmitted first in time. This field shall be protected by the CCITT CRC-16 frame check sequence described in clause 1.2.3.6.

1.2.3.6 PLCP CRC Field (CCITT CRC-16)

The 802.11 SIGNAL, 802.11 SERVICE, and LENGTH fields shall be protected with a CCITT CRC-16 FCS (frame check sequence). The CCITT CRC-16 FCS shall be the ones complement of the remainder generated by the modulo 2 division of the protected PLCP fields by the polynomial:

$$x^{16} + x^{12} + x^5 + 1$$

The protected bits shall be processed in transmit order. All FCS calculations shall be made prior to data scrambling (where used).

As an example, the SIGNAL, SERVICE, and LENGTH fields for a DBPSK signal with a packet length of 192 μ s (24 bytes) would be given by the following:

0101 0000 0000 0000 0000 0011 0000 0000 (left most bit transmitted first in time)

The ones complement FCS for these protected PLCP preamble bits would be the following:

0101 1011 0101 0111 (left most bit transmitted first in time)

Figure 89 depicts this example.

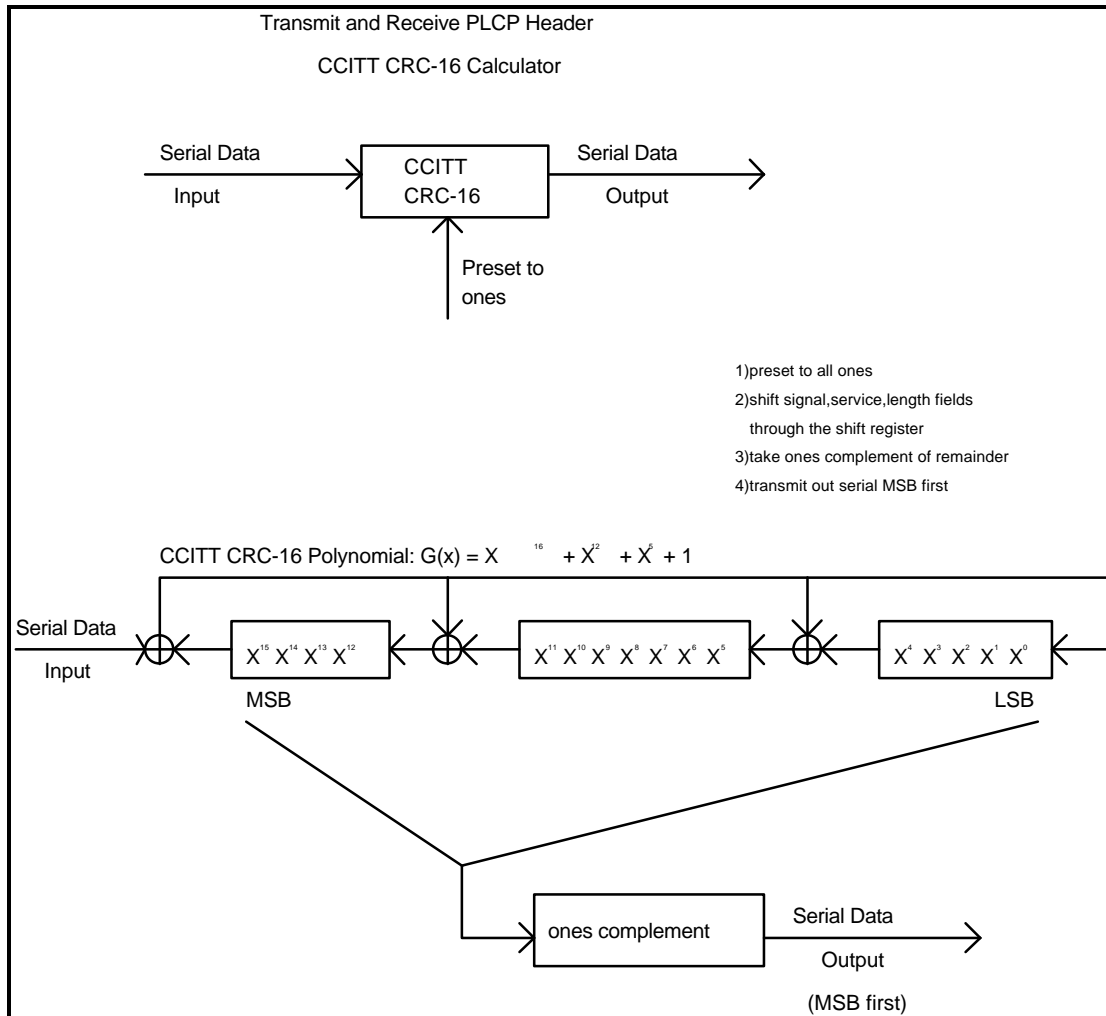

Figure 89, CCITT CRC-16 Implementation

An illustrative example of the CCITT CRC-16 FCS using the above information follows in Figure 90.

Data	CRC Registers		
	MSB	LSB	
	1111111111111111		; Initialize Preset to 1's
0	1110111111011111		
1	1101111110111110		
0	1010111101011101		
1	0101111010111010		
0	1011110101110100		
0	0110101011001001		
0	1101010110010010		
0	1011101100000101		
0	0110011000101011		
0	1100110001010110		
0	1000100010001101		
0	0000000100111011		
0	0000001001110110		
0	0000010011101100		
0	0000100111011000		
0	0001001110110000		
0	0010011101100000		
0	0100111011000000		
0	1001110110000000		
0	0010101100100001		
0	0101011001000010		
0	1010110010000100		
1	0101100100001000		
1	1010001000110001		
0	0101010001000011		
0	1010100010000110		
0	0100000100101101		
0	1000001001011010		
0	0001010010010101		
0	0010100100101010		
0	0101001001010100		
0	1010010010101000		
	0101101101010111		; 1's Complement, Result = CRC FCS Parity

Figure 90, Example CRC Calculation

1.2.4 PLCP / DSSS PHY Data Scrambler and Descrambler

The polynomial $G(z) = z^{-7} + z^{-4} + 1$ shall be used to scramble ALL bits transmitted by the DSSS PHY that are sent with a type 1 header. The feedthrough configuration of the scrambler and descrambler is self synchronizing which requires no prior knowledge of the transmitter initialization of the scrambler for receive processing. Figure

91 and Figure 92 show typical implementations of the data scrambler and descrambler. Other implementations are possible.

The scrambler should be initialized to any state except all ones when transmitting.

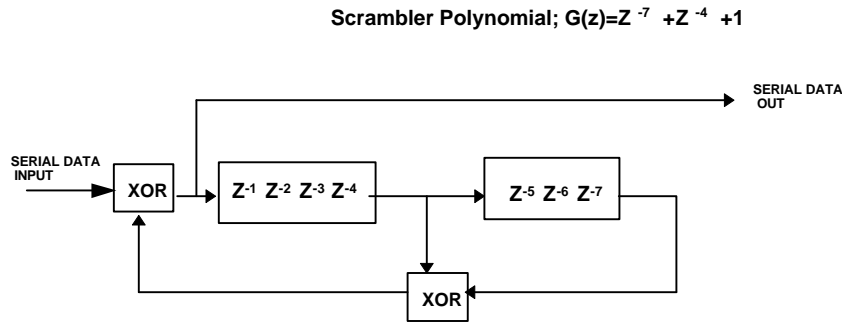

Figure 91, Data Scrambler

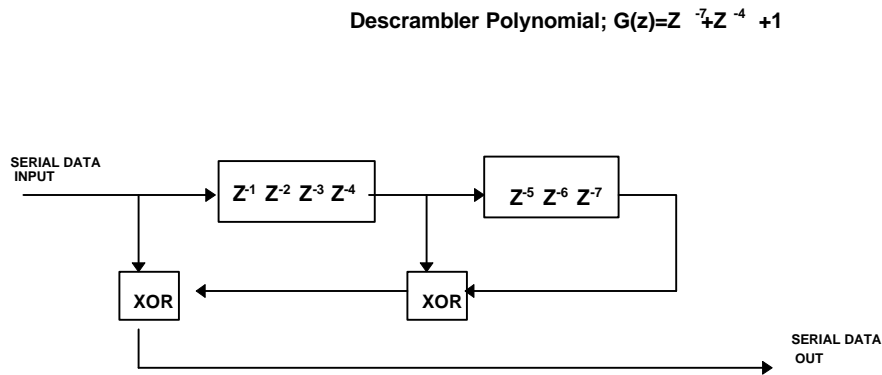

Figure 92, Data Descrambler

All high rate transmissions are scrambled with a frame synchronous scrambler using the same generator polynomial as described above. This scrambler is initiated with a seed of all ones at the first bit of the MPDU and runs to the end of the MPDU, identical to the implementation in the FH PHY. In the case of using the type 1 preamble and header, the scrambler is switched and started at the beginning of the MPDU.

1.2.5 PLCP Data Modulation and Modulation Rate Change

The PLCP preamble shall be transmitted using the 1 Mbit/s DBPSK modulation. The 802.11 SIGNAL field shall indicate the modulation which shall be used to transmit the MPDU. The transmitter and receiver shall initiate the modulation indicated by the 802.11 SIGNAL field starting with the first symbol (1bit for DBPSK, 2 bits for DQPSK, 4 bits for BMBOK, or 8 bits for QMBOK) of the MPDU. The MPDU transmission rate shall be set by the SIGNAL parameter in the TXVECTOR issued with the PHYTXSTART.request primitive described in clause 15.4.4.1.

1.2.6 PLCP Transmit Procedure

The PLCP transmit procedure is shown in Figure 93.

In order to transmit data, PHYTXSTART.request shall be enabled so that the PHY entity shall be in the transmit state. Further, the PHY shall be set to operate at the appropriate CHNL_ID through Station Management via the PLME. Other transmit parameters such as RATE, TX antenna, and TX power are set via the PHY-SAP with the TXSTART.request(TXVECTOR) as described in clause 15.4.4.2.

Based on the status of CCA indicated by PHYCCA.indicate, the MAC will assess that the channel is clear. A clear channel shall be indicated by PHYCCA.indicate(IDLE). If the channel is clear, transmission of the PPDU shall be initiated by issuing the PHYTXSTART.request (TXVECTOR) primitive. The TXVECTOR elements for the PHYTXSTART.request are the PLCP header parameters SIGNAL, SERVICE and LENGTH and the PMD parameters of TX_ANTENNA and TXPWR_LEVEL. The PLCP header parameter LENGTH is calculated from the TXVECTOR element by multiplying by 8 for 1 Mbit/s, by 4 for 2 Mbit/s, 8/5.5 for 5.5 Mbit/s, and 8/11 for 11 Mbit/s,.

The PLCP shall issue PMD_ANTSEL, PMD_RATE, and PMD_TXPWRLVL primitives to configure the PHY. The PLCP shall then issue a PMD_TXSTART.request and the PHY entity shall immediately initiate data scrambling and transmission of the PLCP preamble based on the parameters passed in the PHYTXSTART.request primitive. The time required for TX power on ramp described in clause 15.4.7.7 shall be included in the PLCP synchronization field. Once the PLCP preamble transmission is complete, data shall be exchanged between the MAC and the PHY by a series of PHYDATA.request(DATA) primitives issued by the MAC. The modulation rate change, if any, shall be initiated with the first data symbol of the MPDU as described in clause 15.2.5. The PHY proceeds with MPDU transmission through a series of data octet transfers from the MAC. At the PMD layer, the data octets are sent in LSB to MSB order and presented to the PHY layer through PMD_DATA.request primitives. Optionally, the data can be sent bit serial with no exchange of primitives. Transmission can be prematurely terminated by the MAC through the primitive PHYTXEND.request. PHYTXSTART shall be disabled by the issuance of the PHYTXEND.request. Normal termination occurs after the transmission of the final bit of the last MPDU octet according to the number supplied in the DSSS PHY preamble LENGTH field. The packet transmission shall be completed and the PHY entity shall enter the receive state (i.e. PHYTXSTART shall be disabled). It is required that chipping continue during power ramp down.

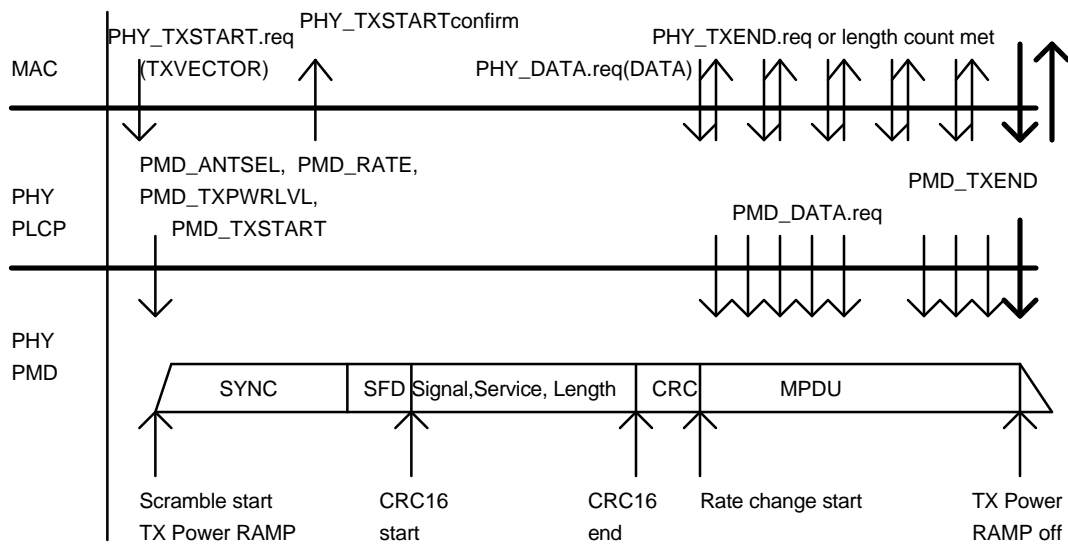
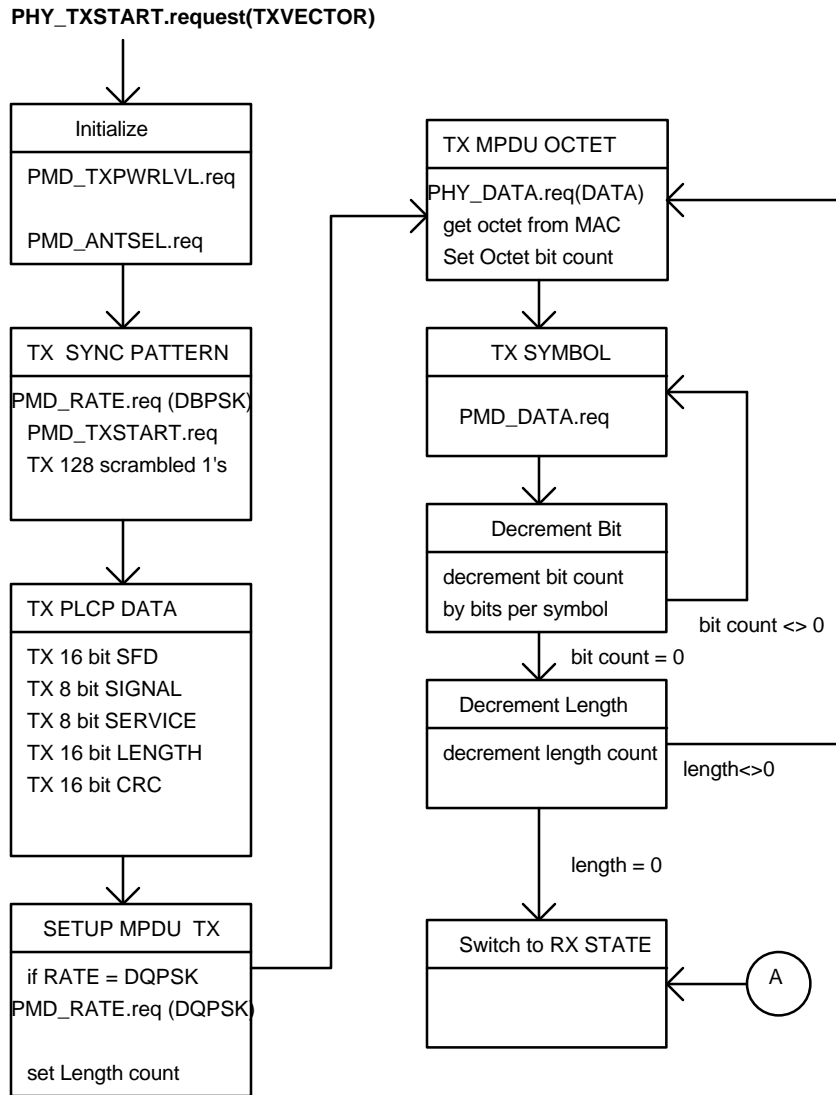

Figure 93, PLCP Transmit Procedure

A typical state machine implementation of the PLCP transmit procedure is provided in Figure 94.



A At any stage in the above flow diagram, if a PHY_TXEND.request is received

Figure 94, PLCP Transmit State Machine

1.2.7 PLCP Receive Procedure

The PLCP receive procedure is shown in Figure 95.

In order to receive data, PHYTXSTART.request shall be disabled so that the PHY entity is in the receive state. Further, through Station Management via the PLME, the PHY is set to the appropriate CHNL_ID and the CCA method is chosen. Other receive parameters such as RSSI, SQ (signal quality) and indicated RATE may be accessed via the PHY-SAP.

Upon receiving the transmitted energy, according to the selected CCA mode, the PMD_ED shall be enabled (according to clause 15.4.8.4) as the RSSI strength reaches the ED_THRESHOLD and/or PMD_CS shall be enabled after code lock is established. These conditions are used to indicate activity to the MAC via PHYCCA.indicate according to clause 15.4.8.4. PHYCCA.indicate(BUSY) shall be issued for energy detection and/or code lock prior to correct reception of the PLCP frame. The PMD primitives PMD_SQ and PMD_RSSI are issued to update the RSSI and SQ parameters reported to the MAC.

After PHYCCA.indicate is issued, the PHY entity shall begin searching for the SFD field. Once the SFD field is detected, CCITT CRC-16 processing shall be initiated and the PLCP 802.11 SIGNAL, 802.11 SERVICE and LENGTH fields are received. The CCITT CRC-16 FCS shall be processed. If the CCITT CRC-16 FCS check fails, the PHY receiver shall return to the RX Idle state as depicted in Figure 96. Should the status of CCA return to the IDLE state during reception prior to completion of the full PLCP processing, the PHY receiver shall return to the RX Idle state.

If the PLCP header reception is successful (and the SIGNAL field is completely recognizable and supported), a PHYRXSTART.indicate(RXVECTOR) shall be issued. The RXVECTOR associated with this primitive includes the SIGNAL field, the SERVICE field, the MPDU length in bytes (calculated from the LENGTH field in microseconds), the antenna used for receive, PHYRSSI and PHYSQ.

The received MPDU bits can be assembled into octets and presented to the MAC using a series of PHYDATA.indicate(DATA) primitive exchanges. The rate change indicated in the 802.11 SIGNAL field shall be initiated with the first symbol of the MPDU as described in clause 15.2.5. The PHY proceeds with MPDU reception. After the reception of the final bit of the last MPDU octet indicated by the PLCP preamble LENGTH field, the receiver shall be returned to the RX Idle state as shown in Figure 96. A PHYRXEND.indicate(NoError) primitive shall be issued. A PHYCCA.indicate(IDLE) primitive shall be issued following a change in PHYCS and/or PHYED according to the selected CCA method.

In the event that a change in PHYCS or PHYED would cause the status of CCA to return to the IDLE state before the complete reception of the MPDU as indicated by the PLCP LENGTH field, the error condition PHYRXEND.indicate(carrierLost) shall be reported to the MAC. The DSSS PHY shall ensure that the CCA shall indicate a busy medium for the intended duration of the transmitted packet.

If the PLCP header is successful, but the indicated rate in the SIGNAL field is not receivable or the SERVICE field is out of 802.11 DSSS specification, a PHYRXSTART.indicate will not be issued. However, the DSSS PHY shall ensure that the CCA shall indicate a busy medium for the intended duration of the transmitted frame as indicated by the LENGTH field. The intended duration is indicated by the LENGTH field (length * 1 μs). The PHY shall issue the error condition PHYRXEND.indicate(FormatViolation).

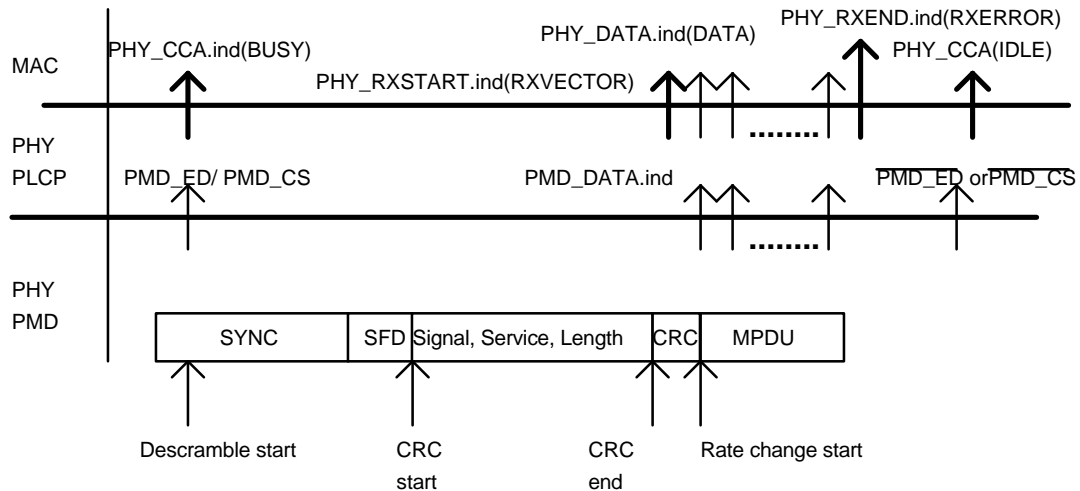

Figure 95, PLCP Receive Procedure

A typical state machine implementation of the PLCP receive procedure is provided in Figure 96.

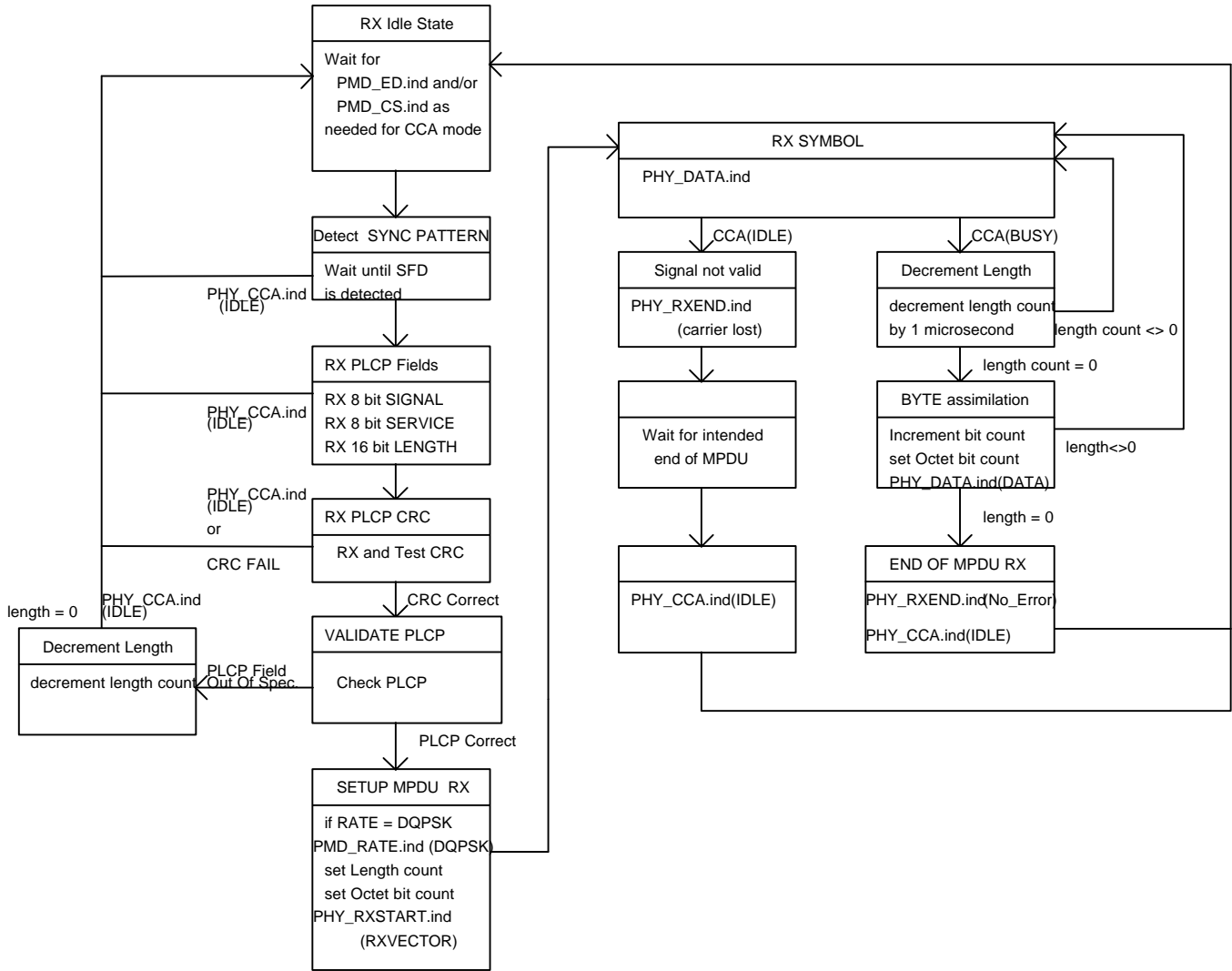

Figure 96, PLCP Receive State Machine

1.3 DSSS Physical Layer Management Entity (PLME)

1.3.1 PLME_SAP Sublayer Management primitives

Table 58 lists the primitives which may be sent between the PHY sublayer entities and intra layer of higher Layer Management Entities (LME).

Primitive	Request	Indicate	Confirm	Response
PLME_CCA_MODE	X			
PLME_CHNL_ID	X			
PLME_DIVERSITY	X			
PLME_DOZE	X			
PLME_RESET	X			
PLME_TEST_MODE	X			
PLME_TEST_OUTPUT	X			

Table 58, PLME_SAP Sublayer Management Primitives

1.3.2 PLME_SAP Management Service Primitive Parameters

Table 59 shows the parameters used by the PLME_SAP primitives.

Parameter	Associated Primitive	Value
CCA_MODE	PLME_CCA_MODE.request	ED_Only, CS_Only, ED and CS
ED_THRESHOLD	PLME_CCA_MODE.request	ED Threshold if required for CCA operation
CHNL_ID	PLME_CHNL_ID.request	as defined in clause 15.4.6.2
ANT_LIST	PLME_DIVERSITY.request	list of valid antennas to search
DIV_MODE	PLME_DIVERSITY.request	Enabled or Disabled
TEST_ENABLE	PLME_TEST_MODE.request	Enabled or Disabled
TEST_MODE	PLME_TEST_MODE.request	Continuous_TX, Transparent_RX, 50% TX/RX
SCRAMBLE_STATE	PLME_TEST_MODE.request	Enabled or Disabled
SPREADING_STATE	PLME_TEST_MODE.request	Enabled or Disabled
DATA_TYPE	PLME_TEST_MODE.request	Ones, Zeros, Revs
DATA_RATE	PLME_TEST_MODE.request	1, 2, 5.5, or 11 Mbit/s
TEST_OUTPUT	PLME_TEST_OUTPUT.request	Enabled or Disabled

Table 59, PLME_SAP Primitive Parameters

1.3.3 PLME_SAP Detailed Service Specification

1.3.3.1 PLME_RESET.request

Function

This primitive shall be a request by the LME to reset the PHY. The PHY shall be always reset to the receive state to avoid accidental data transmission.

Semantics of the Service Primitive

The primitive shall provide the following parameters:

PLME_RESET.request

There are no parameters associated with this primitive.

When Generated

This primitive shall be generated at any time to reset the PHY.

Effect of Receipt

Receipt of this primitive by the PHY sublayer shall cause the PHY entity to reset both the transmit and the receive state machines and place the PHY into the receive state.

1.3.3.2 PLME_CCA_MODE.request

Function

This primitive shall be a request by the LME to establish a particular CCA mode operation for the PHY.

Semantics of the Service Primitive

The primitive shall provide the following parameters:

PLME_CCA_MODE.request(CCA_MODE, ED_THRESHOLD)

CCA_MODE shall indicate one of three CCA operational modes of energy detect only, carrier sense only, or a combination of energy detect and carrier sense.

When Generated

This primitive shall be generated at any time to change the CCA mode used by the PHY.

Effect of Receipt

Receipt of this primitive by the PHY sublayer shall cause the PHY entity to use the specified CCA_MODE with the ED Threshold set as appropriate for the mode of operation.

1.3.3.3 PLME_CHNL_ID.request**Function**

This primitive shall be a request by the LME to set the operational frequency of the PHY.

Semantics of the Service Primitive

The primitive shall provide the following parameters:

PLME_CHNL_ID.request(CHNL_ID)

The CHNL_ID parameter shall be as defined in clause 15.4.6.2.

When Generated

This primitive shall be generated at any time to alter the frequency of operation of the PHY.

Effect of Receipt

Receipt of this primitive by the PHY sublayer shall cause the PHY entity to change the frequency of operation according to the CHNL_ID parameter.

1.3.3.4 PLME_DOZE.request**Function**

This primitive shall be a request by the LME to place the PHY into the DOZE state.

Semantics of the Service Primitive

The primitive shall provide the following parameters:

PLME_DOZE.request

There are no parameters associated with this primitive.

When Generated

This primitive shall be generated at any time to place the PHY into the DOZE state.

Effect of Receipt

Receipt of this primitive by the PHY sublayer shall cause the PHY entity to place itself into the DOZE state.

1.3.3.5 PLME_DIVERSITY.request**Function**

This primitive shall be a request by the LME to enable or disable the PHY from using antenna diversity.

Semantics of the Service Primitive

The primitive shall provide the following parameters:

PLME_DIVERSITY.request(DIV_MODE,ANT_LIST)

DIV_MODE shall cause the diversity function to be enabled or disabled. ANT_LIST shall contain the antenna numbers which are valid to search.

When Generated

This primitive shall be generated at any time to change the operating mode of antenna diversity.

Effect of Receipt

Receipt of this primitive by the PHY sublayer shall cause the PHY entity to change the operating state of the antenna diversity function according to the parameters DIV_MODE and ANT_LIST.

1.3.3.6 PLME_TEST_MODE.request**Function**

This primitive shall be a request by the LME to establish a test mode operation for the PHY. The parameters associated with this primitive are considered as recommendations and are optional in any particular implementation.

Semantics of the Service Primitive

The primitive shall provide the following parameters:

PLME_TEST_MODE.request(TEST_ENABLE, TEST_MODE, SCRAMBLE_STATE, SPREADING_STATE, DATA_TYPE, DATA_RATE)

TEST_ENABLE enables and disables the PHY test mode according to the remaining parameters; TEST_MODE selects one of three operational states: transparent receive, continuous transmit, 50 percent duty cycle TX/RX; SCRAMBLE_STATE sets the operational state of the scrambler; SPREADING_STATE selects the operational state of the chipping; DATA_TYPE selects one of three data patterns to be used for the transmit portions of the tests; DATA_RATE selects between 1 and 2 Mbit/s operation.

When Generated

This primitive shall be generated at any time to enter the PHY test mode.

Effect of Receipt

Receipt of this primitive by the PHY sublayer shall cause the PHY entity to enter the test mode of operation.

1.3.3.7 PLME_TEST_OUTPUT.request**Function**

This optional primitive shall be a request by the LME to enable selected test signals from the PHY. The parameters associated with this primitive are considered as recommendations and are optional in any particular implementation.

Semantics of the Service Primitive

The primitive shall provide the following parameters:

PLME_TEST_OUTPUT.request(TEST_OUTPUT)

TEST_OUTPUT enables and disables selected signals for debugging and testing the PHY. Some signals which may be available for output are PHYTXSTART.request, PHYRXSTART.indicate(RXVECTOR), CCA_INDICATE.indicate, the chipping clock, the data clock, the symbol clock, TX data and RX data.

When Generated

This primitive shall be generated at any time to enable the test outputs when in the PHY test mode.

Effect of Receipt

Receipt of this primitive by the PHY sublayer shall cause the PHY entity to enabled the test outputs.

1.3.4 DSSS Physical Layer Management Information Base

All DSSS Physical Layer Management Information Base attributes are defined in clause 12 with specific values defined in Table 60.

Managed Object	Default Value / Range	Operational Semantics
agPhyOperationGroup		
aPHYType	DSSS-2.4 (02)	Static
aTempType	implementation dependent	Static
aCWmin	31	Static
aCWmax	1023	Static
aCurrentRegDomain	implementation dependent	Static
aSlotTime	20 μs	Static
aCCATime	≤ 15 μs	Static
aRxTxTurnaroundTime	≤ 5 μs	Static
aTxPLCPDelay	implementation dependent	Static
aRxTxSwitchTime	≤ 5 μs	Static
aTxRampOnTime	implementation dependent	Static
aTxRFDelay	implementation dependent	Static
aSIFSTime	10 μs	Static
aRxRFDelay	implementation dependent	Static
aRxPLCPDelay	implementation dependent	Static
aMACProcessingDelay	not applicable	n/a
aTxRampOffTime	implementation dependent	Static
aPreambleLength	144 symbols (interoperable preamble), 44 symbols (short HR preamble)	Static
aPLCPHeaderLength	48 bits (interoperable header), 34 bits (short HR header)	Static
agPhyRateGroup		
aSupportedDataRatesTx	0Ah, 14h, 37h, 6Eh	Static
aSupportedDataRatesRx	0Ah, 14h, 37h, 6Eh	Static
aMPDUMaxLength	4 ≤ x ≤ (2 ¹³ - 1)	Static
agPhyAntennaGroup		
aCurrentTxAntenna	implementation dependent	Dynamic
aDiversitySupport	implementation dependent	Static
agPhyTxPowerGroup		

aNumberSupportedPowerLevels	implementation dependent	Static
aTxPowerLevel1	implementation dependent	Static
aTxPowerLevel2	implementation dependent	Static
aTxPowerLevel3	implementation dependent	Static
aTxPowerLevel4	implementation dependent	Static
aTxPowerLevel5	implementation dependent	Static
aTxPowerLevel6	implementation dependent	Static
aTxPowerLevel7	implementation dependent	Static
aTxPowerLevel8	implementation dependent	Static
aCurrentTxPowerLevel	implementation dependent	Dynamic
agPhyStatusGroup		
aSynthesizerLocked	implementation dependent	Dynamic
agPhyDSSSGroup		
aCurrentChannel	implementation dependent	Dynamic
aCCAModeSupport	implementation dependent	Static
aCurrentCCAMode	implementation dependent	Dynamic
aEDThreshold	implementation dependent	Dynamic
agPhyPwrSavingGroup		
aDozeTurnonTime	implementation dependent	Static
aCurrentPowerState	implementation dependent	Dynamic
agAntennasListGroup		
aSupportTxAntennas	implementation dependent	Static
aSupportRxAntennas	implementation dependent	Static
aDiversitySelectRx	implementation dependent	Dynamic
Not Grouped		
aRegDomainsSupported	implementation dependent	Static

Table 60, MIB Attribute Default Values / Ranges

Notes: The column titled Operational Semantics contains two types: static and dynamic. Static MIB attributes are fixed and cannot be modified for a given PHY implementation. MIB Attributes defined as dynamic can be modified by some management entity.

1.4 DSSS Physical Medium Dependent Sublayer

1.4.1 Scope and Field of Application

This clause describes the PMD services provided to the PLCP for the DSSS Physical Layer. Also defined in this clause are the functional, electrical and RF characteristics required for interoperability of implementations conforming to this specification. The relationship of this specification to the entire DSSS PHY Layer is shown in Figure 97.

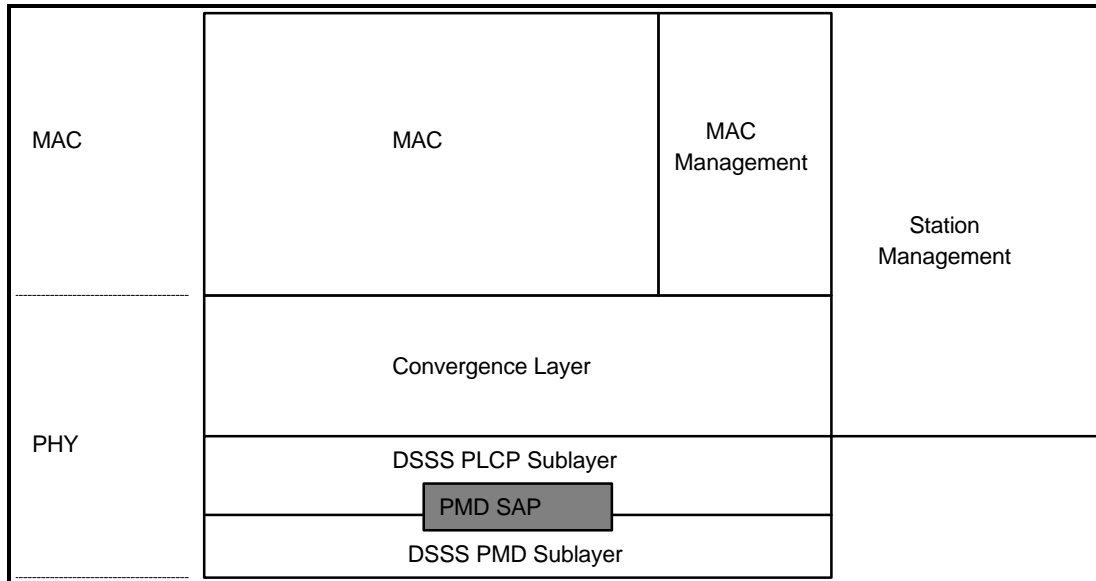

Figure 97, PMD Layer Reference Model

1.4.2 Overview of Service

The DSSS Physical Medium Dependent Sublayer accepts Physical Layer Convergence Procedure sublayer service primitives and provides the actual means by which data shall be transmitted or received from the medium. The combined function of DSSS PMD sublayer primitives and parameters for the receive function results in a data stream, timing information, and associated received signal parameters being delivered to the PLCP sublayer. A similar functionality shall be provided for data transmission.

1.4.3 Overview of Interactions

The primitives associated with the 802.11 PLCP sublayer to the DSSS PMD falls into two basic categories:

- a) Service primitives that support PLCP peer-to-peer interactions.
- b) Service primitives that have local significance and support sublayer-to-sublayer interactions.

1.4.4 Basic Service and Options

All of the service primitives described in this clause are considered mandatory unless otherwise specified.

1.4.4.1 PMD_SAP Peer-to-Peer Service Primitives

Table 61 indicates the primitives for peer-to-peer interactions.

Primitive	Request	Indicate	Confirm	Response
PHYRXSTART		X		
PHYRXEND		X		
PHYCCA		X		
PHYTXSTART	X		X	
PHYTXEND	X		X	
PHYDATA	X	X	X	

Table 61, PMD_SAP Peer-to-Peer Service Primitives

1.4.4.2 PMD_SAP Peer-to-Peer Service Primitive Parameters

Several service primitives include a parameter vector. This vector shall be actually a list of parameters which may vary depending on PHY type. Table 62 indicates the parameters required by the MAC or DSSS PHY in each of the parameter vectors used for peer-to-peer interactions.

Parameter	Associated Primitive	Value
LENGTH	RXVECTOR, TXVECTOR	4 to $2^{16}-1$
SIGNAL	RXVECTOR, TXVECTOR	PHY dependent
SERVICE	RXVECTOR, TXVECTOR	PHY dependent
TXPWR_LEVEL	TXVECTOR	PHY dependent
TX_ANTENNA	TXVECTOR	PHY dependent
RSSI	RXVECTOR	PHY dependent
SQ	RXVECTOR	PHY dependent
RX_ANTENNA	RXVECTOR	PHY dependent

Table 62, DSSS PMD_SAP Peer-to-Peer Service Primitives

1.4.4.3 PMD_SAP Sublayer-to-Sublayer Service Primitives

Primitive	Request	Indicate	Confirm	Response
PMD_TXSTART	X			
PMD_TXEND	X			
PMD_ANTSEL	X	X		
PLME_DIVERSITY	X			
PMD_TXPWRVL	X			
PLME_CHANNEL	X			
PMD_RATE	X	X		
PMD_RSSI		X		
PMD_SQ		X		
PMD_CS		X		
PMD_ED	X	X		

Table 63, PMD_SAP Sublayer-to-Sublayer Service Primitives

1.4.4.4 PMD_SAP Service Primitive Parameters

Parameter	Associate Primitive	Value
DATA	PHYDATA.request PHYDATA.indicate	octet value: 00h-FFh
TXVECTOR	PHYDATA.request	a set of parameters
RXVECTOR	PHYDATA.indicate	a set of parameters
TXD_UNIT	PMD_DATA.request	One(1), Zero(0): DBPSK di bit combinations 00,01,11,10: DQPSK 4 bit nibbles, LSB first: BMBOK 8 bit bytes, LSB first: QMBOK
RXD_UNIT	PMD_DATA.indicate	One(1), Zero(0): DBPSK di bit combinations 00,01,11,10: DQPSK 4 bit nibbles, LSB first: BMBOK 8 bit bytes, LSB first: QMBOK
RF_STATE	PMD_TXE.request	Receive, Transmit

ANT_STATE	PMD_ANTSEL.indicate PMD_ANTSEL.request	1 to 256
DIV_CONTROL	PLME_DIVERSITY.request	On, Off
TXPWR_LEVEL	PHY_TXSTART	0,1,2,3 (max of 4 levels)
CHNL_ID	PLME_CHANNEL.request	as defined in clause 15.4.6.2
RATE	PMD_RATE.indicate PMD_RATE.request	0Ah for 1 Mbit/s DBPSK 14h for 2 Mbit/s DQPSK 37h for 5.5 Mbit/s BMBOK 6Eh for 11 Mbit/s QMBOK
RSSI	PMD_RSSI.indicate	0-8 bits of RSSI
SQ	PMD_SQ.indicate	0-8 bits of Signal Quality

Table 64, List of Parameters for the PMD Primitives

1.4.5 PMD_SAP Detailed Service Specification

The following clause describes the services provided by each PMD primitive.

1.4.5.1 PMD_DATA.request

Function

This primitive defines the transfer of data from the PLCP sublayer to the PMD entity.

Semantic of the Service Primitive

The primitive shall provide the following parameters:

PMD_DATA.request(TXD_UNIT)

For the 1 and 2 Mbit/s rates, the TXD_UNIT parameter takes on the value of either ONE(1) or ZERO(0) for DBPSK modulation or the di-bit combination 00, 01, 11, or 10 for DQPSK modulation. For the two higher rates, the TXD_UNIT parameter is a 4 bit nibble for the 5.5 Mbit/s modulation, or an 8 bit byte for the 11 Mbit/s modulation. This parameter represents a single block of data which in turn shall be used by the PHY to be either differentially encoded into a DBPSK or DQPSK transmitted symbol or encoded into a BMBOK or QMBOK transmitted symbol. The DBPSK or DQPSK transmitted symbols shall be spread by the 11 chip PN code prior to transmission. The BMBOK or QMBOK transmitted symbols shall be spread by the 8 chip PN code prior to transmission.

When Generated

This primitive shall be generated by the PLCP sublayer to request transmission of a symbol. The data clock for this primitive shall be supplied by PMD layer based on the PN code repetition.

Effect of Receipt

The PMD performs the differential encoding, PN code modulation and transmission of the data.

1.4.5.2 PMD_DATA.indicate

Function

This primitive defines the transfer of data from the PMD entity to the PLCP sublayer.

Semantic of the Service Primitive

The primitive shall provide the following parameters:

PMD_DATA.indicate(RXD_UNIT)

For the 1 and 2 Mbit/s rates, the RXD_UNIT parameter takes on the value of either ONE(1) or ZERO(0) for DBPSK modulation or the di-bit combination 00, 01, 11, or 10 for DQPSK modulation. For the two higher rates, the RXD_UNIT parameter is a 4 bit nibble for the 5.5 Mbit/s modulation, or an 8 bit byte for the 11 Mbit/s modulation. This parameter represents a single symbol which has been demodulated by the PMD entity.

When Generated

This primitive generated by the PMD entity, forwards received data to the PLCP sublayer. The data clock for this primitive shall be supplied by PMD layer based on the PN code repetition.

Effect of Receipt

The PLCP sublayer either interprets the bit or bits which are recovered as part of the PLCP convergence procedure or passes the data to the MAC sublayer as part of the MPDU.

1.4.5.3 PMD_TXSTART.request

Function

This primitive, generated by the PHY PLCP sublayer, initiates PPDU transmission by the PMD layer.

Semantic of the Service Primitive

The primitive shall provide the following parameters:

PMD_TXSTART.request

When Generated

This primitive shall be generated by the PLCP sublayer to initiate the PMD layer transmission of the PPDU. The PHYDATA.request primitive shall be provided to the PLCP sublayer prior to issuing the PMD_TXSTART command.

Effect of Receipt

PMD_TXSTART initiates transmission of a PPDU by the PMD sublayer.

1.4.5.4 PMD_TXEND.request

Function

This primitive, generated by the PHY PLCP sublayer, ends PPDU transmission by the PMD layer.

Semantic of the Service Primitive

The primitive shall provide the following parameters:

PMD_TXEND.request

When Generated

This primitive shall be generated by the PLCP sublayer to terminate the PMD layer transmission of the PPDU.

Effect of Receipt

PMD_TXEND terminates transmission of a PPDU by the PMD sublayer.

1.4.5.5 PMD_ANTSEL.request

Function

This primitive, generated by the PHY PLCP sublayer, selects the antenna used by the PHY for transmission or reception (when diversity is disabled).

Semantic of the Service Primitive

The primitive shall provide the following parameters:

PMD_ANTSEL.request(ANT_STATE)

ANT_STATE selects which of the available antennas should be used for transmit. The number of available antennas shall be determined from the MIB table parameters aSuprRxAntennas and aSuprTxAntennas.

When Generated

This primitive shall be generated by the PLCP sublayer to select a specific antenna for transmission (or reception when diversity is disabled).

Effect of Receipt

PMD_ANTSEL immediately selects the antenna specified by ANT_STATE.

1.4.5.6 PMD_ANTSEL.indicate

Function

This primitive, generated by the PHY PLCP sublayer, reports the antenna used by the PHY for reception of the most recent packet.

Semantic of the Service Primitive

The primitive shall provide the following parameters:

PMD_ANTSEL.indicate(ANT_STATE)

ANT_STATE reports which of the available antennas was used for reception of the most recent packet.

When Generated

This primitive shall be generated by the PLCP sublayer to report the antenna used for the most recent packet reception.

Effect of Receipt

PMD_ANTSEL immediately reports the antenna specified by ANT_STATE.

1.4.5.7 PLME_DIVERSITY.request

Function

This primitive, generated by the PHY PLME sublayer, selects whether antenna diversity shall be enabled or disabled during reception.

Semantic of the Service Primitive

The primitive shall provide the following parameters:

PLME_DIVERSITY.request(DIV_CONTROL)

DIV_CONTROL selects whether the diversity function shall be enabled or not.

When Generated

This primitive shall be generated by the PLCP sublayer to change the operating state of the receive state machine to select a specific antenna for reception or to allow diversity function.

Effect of Receipt

PLME_DIVERSITY immediately alters the receive state machine according to the DIV_CONTROL parameter.

1.4.5.8 PMD_TXPWRLVL.request

Function

This primitive, generated by the PHY PLCP sublayer, selects the power level used by the PHY for transmission.

Semantic of the Service Primitive

The primitive shall provide the following parameters:

PMD_TXPWRLVL.request(TXPWR_LEVEL)

TXPWR_LEVEL selects which of the optional transmit power levels should be used for the current packet transmission. The number of available power levels shall be determined by the MIB parameter aNumberSupportedPowerLevels. Clause 15.4.7.3 provides further information on the optional DSSS PHY power level control capabilities.

When Generated

This primitive shall be generated by the PLCP sublayer to select a specific transmit power. This primitive shall be applied prior to setting PMD_TXSTART into the transmit state.

Effect of Receipt

PMD_TXPWRLVL immediately sets the transmit power level given by TXPWR_LEVEL.

1.4.5.9 PLME_CHANNEL.request

Function

This primitive, generated by the PHY PLME sublayer, selects the channel frequency which shall be used by the DSSS PHY for transmission or reception.

Semantics of the Service Primitive

The primitive shall provide the following parameters:

PLME_CHANNEL.request(CHNL_ID)

CHNL_ID selects which of the DSSS PHY channel frequencies shall be used for transmission or reception. Clause 15.4.6.2 provides further information on the DSSS PHY channel plan.

When Generated

This primitive shall be generated by the PLME sublayer to change or set the current DSSS PHY channel.

Effect of Receipt

The receipt of PLME_CHANNEL immediately changes the operating channel as set by the CHNL_ID parameter.

1.4.5.10 PMD_RATE.request

Function

This primitive, generated by the PHY PLCP sublayer, selects the modulation RATE which shall be used by the DSSS PHY for transmission.

Semantic of the Service Primitive

The primitive shall provide the following parameters:

PMD_RATE.request(RATE)

RATE selects which of the DSSS PHY data rates shall be used for MPDU transmission. Clause 15.4.6.4 provides further information on the DSSS PHY modulation rates. The DSSS PHY rate change capability is fully described in clause 15.2.

When Generated

This primitive shall be generated by the PLCP sublayer to change or set the current DSSS PHY modulation rate used for the MPDU portion of a PPDU.

Effect of Receipt

The receipt of PHYRATE selects the rate which shall be used for all MPDU transmissions. This rate shall be used for transmission only. The DSSS PHY shall still be capable of receiving all the required DSSS PHY modulation rates.

1.4.5.11 PMD_RATE.indicate

Function

This primitive, generated by the PMD sublayer, indicates which modulation rate was used to receive the MPDU portion of the PPDU. The modulation shall be indicated in the PLCP preamble 802.11 SIGNALING field.

Semantic of the Service Primitive

The primitive shall provide the following parameters:

PMD_RATE.indicate(RATE)

In receive mode, the RATE parameter informs the PLCP layer which of the DSSS PHY data rates was used to process the MPDU portion of the PPDU. Clause 15.4.6.4 provides further information on the DSSS PHY modulation rates. The DSSS PHY rate change capability is fully described in clause 15.2.

When Generated

This primitive shall be generated by the PMD sublayer when the PLCP preamble 802.11 SIGNALING field has been properly detected.

Effect of Receipt

This parameter shall be provided to the PLCP layer for information only.

1.4.5.12 PMD_RSSI.indicate**Function**

This optional primitive, generated by the PMD sublayer, provides to the PLCP and MAC entity the Received Signal Strength.

Semantic of the Service Primitive

The primitive shall provide the following parameters:

PMD_RSSI.indicate(RSSI)

The RSSI shall be a measure of the RF energy received by the DSSS PHY. RSSI indications of up to 8 bits (256 levels) are supported.

When Generated

This primitive shall be generated by the PMD when the DSSS PHY is in the receive state. It shall be continuously available to the PLCP which in turn provides the parameter to the MAC entity.

Effect of Receipt

This parameter shall be provided to the PLCP layer for information only. The RSSI may be used in conjunction with SQ as part of a Clear Channel Assessment scheme.

1.4.5.13 PMD_SQ.indicate**Function**

This optional primitive, generated by the PMD sublayer, provides to the PLCP and MAC entity the Signal Quality of the DSSS PHY PN code correlation. The signal quality shall be sampled when the DSSS PHY achieves code lock and held until the next code lock acquisition.

Semantic of the Service Primitive

The primitive shall provide the following parameters:

PMD_SQ.indicate(SQ)

The SQ shall be a measure of the PN code correlation quality received by the DSSS PHY. SQ indications of up to 8 bits (256 levels) are supported.

When Generated

This primitive shall be generated by the PMD when the DSSS PHY is in the receive state and code lock is achieved. It shall be continuously available to the PLCP which in turn provides the parameter to the MAC entity.

Effect of Receipt

This parameter shall be provided to the PLCP layer for information only. The SQ may be used in conjunction with RSSI as part of a Clear Channel Assessment scheme.

1.4.5.14 PMD_CS.indicate

This primitive, generated by the PMD, shall indicate to the PLCP layer that the receiver has acquired (locked) the PN code and data is being demodulated.

Function

This primitive, generated by the PMD, shall indicate to the PLCP layer that the receiver has acquired (locked) the PN code and data is being demodulated.

Semantic of the Service Primitive

The PMD_CS (Carrier Sense) primitive in conjunction with PMD_ED provide CCA status through the PLCP layer PHYCCA primitive. PMD_CS indicates a binary status of ENABLED or DISABLED. PMD_CS shall be ENABLED when the correlator signal quality indicated in PMD_SQ is greater than the CS_THRESHOLD parameter. PMD_CS shall be DISABLED when the PMD_SQ falls below the correlation threshold.

When Generated

This primitive shall be generated by the PHY sublayer when the DSSS PHY is receiving a PPDU and the PN code has been acquired.

Effect of Receipt

This indicator shall be provided to the PLCP for forwarding to the MAC entity for information purposes through the PHYCCA indicator. This parameter shall indicate that the RF medium is busy and occupied by a DSSS PHY signal. The DSSS PHY should not be placed into the transmit state when PMD_CS is ENABLED.

1.4.5.15 PMD_ED.indicate

Function

This optional primitive, generated by the PMD, shall indicate to the PLCP layer that the receiver has detected RF energy indicated by the PMD_RSSI primitive which is above a predefined threshold.

Semantic of the Service Primitive

The PMD_ED (Energy Detect) primitive along with the PMD_SQ provide CCA status at the PLCP layer through the PHYCCA primitive. PMD_ED indicates a binary status of ENABLED or DISABLED. PMD_ED shall be ENABLED when the RSSI indicated in PMD_RSSI is greater than the ED_THRESHOLD parameter. PMD_ED shall be DISABLED when the PMD_RSSI falls below the energy detect threshold.

When Generated

This primitive shall be generated by the PHY sublayer when the PHY is receiving RF energy from any source which exceeds the ED_THRESHOLD parameter.

Effect of Receipt

This indicator shall be provided to the PLCP for forwarding to the MAC entity for information purposes through the PMD_ED indicator. This parameter shall indicate that the RF medium may be busy with an RF energy source which is not DSSS PHY compliant. If a DSSS PHY source is being received, the PMD_CS function shall be enabled shortly after the PMD_ED function is enabled.

1.4.5.16 PMD_ED.request

Function

This optional primitive, generated by the PHY PLCP, sets the energy detect ED_THRESHOLD value.

Semantics of the Service Primitive

The primitive shall provide the following parameters:

PMD_ED.request(ED_THRESHOLD)

ED_THRESHOLD sets the threshold which the RSSI indicated shall be greater than in order for PMD_ED to be enabled.

When Generated

This primitive shall be generated by the PLCP sublayer to change or set the current DSSS PHY energy detect threshold.

Effect of Receipt

The receipt of PMD_ED immediately changes the energy detection threshold as set by the ED_THRESHOLD parameter.

1.4.5.17 PHYCCA.indicate

Function

This primitive, generated by the PMD, indicates to the PLCP layer that the receiver has detected RF energy which adheres to the CCA algorithm.

Semantic of the Service Primitive

The PHYCCA primitive provides CCA status at the PLCP layer to the MAC.

When Generated

This primitive shall be generated by the PHY sublayer when the PHY is receiving RF energy from any source which exceeds the ED_THRESHOLD parameter (PMD_ED is active) and optionally is a valid correlated DSSS PHY signal whereby PMD_CS would also be active.

Effect of Receipt

This indicator shall be provided to the PLCP for forwarding to the MAC entity for information purposes through the PHYCCA indicator. This parameter indicates that the RF medium may be busy with an RF energy source which may or may not be DSSS PHY compliant. If a DSSS PHY source is being received, the PMD_CS function shall be enabled shortly after the PMD_ED function is enabled.

1.4.6 PMD Operating Specifications General

The following clauses provide general specifications for the DSSS Physical Medium Dependent sublayer. These specifications apply to both the receive and the transmit functions and general operation of a DSSS PHY.

1.4.6.1 Operating Frequency Range

The DSSS PHY shall operate in the frequency range of 2.4 to 2.4835 GHz as allocated by regulatory bodies in the USA and Europe or in the 2.471 to 2.497 GHz frequency band as allocated by regulatory authority in Japan.

1.4.6.2 Number of Operating Channels

The channel center frequencies and CHNL_ID numbers shall be as shown in Table 65. The FCC (US), IC (Canada) and ETSI (Europe) specify operation from 2.4 to 2.4835 GHz. For Japan, operation is specified as 2.471 to 2.497 GHz. France allows operation from 2.4465 to 2.4835 GHz and Spain allows operation from 2.445 to 2.475 GHz. For each supported regulatory domain, all channels in Table 65 marked with 'X' shall be supported.

CHNL_ID	Frequency	Regulatory Domains					
		10h FCC	20h IC	30h ETSI	31h France	32h Spain	40h MKK

1	2412 MHz	X	X	X	-	-	-
2	2417 MHz	X	X	X	-	-	-
3	2422 MHz	X	X	X	-	-	-
4	2427 MHz	X	X	X	-	-	-
5	2432 MHz	X	X	X	-	-	-
6	2437 MHz	X	X	X	-	-	-
7	2442 MHz	X	X	X	-	-	-
8	2447 MHz	X	X	X	-	-	-
9	2452 MHz	X	X	X	-	-	-
10	2457 MHz	X	X	X	X	X	-
11	2462 MHz	X	X	X	X	X	-
12	2467 MHz	-	X	X	X	-	-
13	2472 MHz	-	X	X	X	-	-
14	2484 MHz	-	-	-	-	-	X

Table 65, DSSS PHY Frequency Channel Plan

In a multiple cell network topology, overlapping and/or adjacent cells using different channels can operate simultaneously without interference if the distance between the center frequencies is at least 30 MHz. Channel 14 shall be designated specifically for operation in Japan.

1.4.6.3 Spreading Sequence

The following 11 chip Barker sequence shall be used as the PN code sequence for spreading the preamble and header:

+1, -1,+1,+1, -1,+1, +1, +1, -1, -1, -1

The left most chip shall be output first in time. The first chip shall be aligned at the start of a transmitted symbol. The symbol duration shall be exactly 11chips long.

The 5.5 and 11 Mbit/s rates shall be spread by the Walsh modulation set as defined below. This consists of the Walsh function basis set with a cover code that is applied at the chipping rate and is designed to minimize the low frequency spectrum components introduced by the Walsh (0) term.

1.4.6.4 Modulation and Channel Data Rates

Four modulation formats and data rates are specified for the DSSS. The preamble synchronization field is modulated with 1 Mbit/s DBPSK modulation. The DBPSK encoder is specified in Table 66. The Start Frame Delimiter is modulated with the 2 Mbit/s Rate which is based on DQPSK. The DQPSK encoder is specified in Table 67. (In the tables, +jω shall be defined as counterclockwise rotation.)

Bit Input	Phase Change (+jω)
0	0
1	π

Table 66, 1 Mbit/s DBPSK Encoding Table

Dibit pattern (d0,d1) d0 is first in time	Phase Change (+jω)
00	0
01	π/2
11	π
10	3π/2 (-π/2)

Table 67, 2 Mbit/s DQPSK Encoding Table

The header and some MPDU packets are modulated with the 5.5 Mbit/s Binary M-ary Bi-Orthogonal Keying modulation which is based on 8 bit Walsh codes using Bi-Orthogonal modulation as defined on page 192 of Lindsey and Simon's book: "Telecommunications Systems Engineering", Prentis Hall publisher (1973). The coding of the 4 bit nibbles shall be in accordance with table 68. The transmit Walsh function shall be used to BPSK modulate the carrier at the chipping rate of 11 Mchip/s. The symbol rate shall be 1.375 Msymbol/s. This modulation is labeled BMBOK.

The phase coherent demodulator for this waveform is described in figure 5-11 of the above referenced book. To enable the receiver to demodulate this Bi-Orthogonal modulation, the absolute phase of the carrier must be known. The reference phase for the MPDU modulation shall be the phase of the last transmitted bit of the CRC-16 in the Header. That is, all subsequent phase shifts of the carrier will be relative to this reference bit phase. A Walsh code bit of 0 shall be encoded as a 0 radians phase shift of the carrier and a Walsh code bit of 1 shall be encoded as a π radians phase shift.

Data Nibble Sign-magnitude	Transmit Walsh Code LSB-MSB LSB is transmitted first in time
0000	11000000
0001	00110000
0011	00001100
0010	11111100
0100	01101010
0101	10011010
0110	10100110
0111	01010110
1000	00111111
1001	11001111
1011	11110011
1010	00000011
1100	10010101
1101	01100101
1110	01011001
1111	10101001

Table 68, 5.5 Mbit/s Encoding Table

The 11 Mbit/s Quadrature M-ary Bi-Orthogonal Keying modulation for the highest rate packets is implemented with 8 bit symbols sent at a rate of 1.375 MSps. The input data shall be grouped into two 4 bit nibbles and the coding of each of the 4 bit nibbles shall be in accordance with table 68. The carrier signal shall be divided into two orthogonal carrier components known as the In-phase or I channel and the Quadrature or Q channel. The first nibble shall be used to encode the Q channel and the second to encode the I channel of the carrier in the same manner as defined above for 5.5 Mbit/s modulation. Each orthogonal channel will carry 5.5 Mbit/s for a total of 11 Mbit/s. This modulation is labeled QMBOK.

1.4.6.5 Transmit and Receive In Band and Out of Band Spurious Emissions

The DSSS PHY shall conform with in-band and out-of-band spurious emissions as set by regulatory bodies. For the USA, refer to FCC 15.247, 15.205, and 15.209. For Europe, refer to ETS 300-328.

1.4.6.6 Transmit to Receive Turnaround Time

The TX to RX turnaround time shall be less than 10 μ s including the power down ramp specified in clause 15.4.7.7.

The TX to RX turnaround time shall be measured at the air interface from the trailing edge of the last transmitted symbol to valid CCA detection of the incoming signal. The CCA should occur within 25 μ s (10 μ s for turnaround time plus 15 μ s for energy detect) or by the next slot boundary occurring after the 25 μ s has elapsed (refer to clause 15.4.8.4). A receiver input signal 3dB above the ED threshold described in clause 15.4.8.4 shall be present at the receiver.

1.4.6.7 Receive to Transmit Turnaround Time

The RX to TX turnaround time shall be measured at the MAC/PHY interface, using PHYTXSTART.request and shall be less than or equal to 5 μ s. This includes the transmit power up ramp described in clause 15.4.7.7.

1.4.6.8 Slot Time

The slot time for the DSSS PHY shall be the sum of the RX to TX turnaround time (5 μ s) and the energy detect time (15 μ s specified in clause 15.4.8.4). The propagation delay shall be regarded to be included in the energy detect time.

1.4.6.9 Transmit and Receive Antenna Port Impedance

The transmit and receive antenna port(s) impedance shall be 50 Ω if the port is exposed.

1.4.6.10 Transmit and Receive Operating Temperature Range

Three temperature ranges for full operation compliance to the DSSS PHY are specified in clause 13. Type 1 shall be defined as 0°C to 40°C is designated for office environments. Type 2 shall be defined as -20°C to +50°C and Type 3 defined as -30°C to +70°C are designated for industrial environments.

1.4.7 PMD Transmit Specifications

The following clauses describe the transmit functions and parameters associated with the Physical Medium Dependent sublayer.

1.4.7.1 Transmit Power Levels

The maximum allowable output power as measured in accordance with practices specified by the regulatory bodies is shown in Table 68. In the USA, the radiated emissions should also conform with the ANSI uncontrolled radiation emission standards (ANSI/IEEE C95.1-1992 or IEEE C95.1-1991).

Maximum Output Power	Geographic Location	Compliance Document
1000 mW	USA	FCC 15.247
100 mW (EIRP)	EUROPE	ETS 300-328
10 mW/MHz	JAPAN	MPT ordinance 79

Table 68, Transmit Power Levels

1.4.7.2 Minimum Transmitted Power Level

The minimum transmitted power shall be no less than 1 mW.

1.4.7.3 Transmit Power Level Control

Power control shall be provided for transmitted power greater than 100 mW. A maximum of 4 power levels may be provided. At a minimum, a radio capable of transmission greater than 100 mW shall be capable of switching power back to 100 mW or less.

1.4.7.4 Transmit Spectrum Mask

The transmitted spectral products shall be less than -30 dBr (dB relative to the SINx/x peak) for $f_c - 22 \text{ MHz} < f < f_c - 11 \text{ MHz}$ and $f_c + 11 \text{ MHz} < f < f_c + 22 \text{ MHz}$ and -50 dBr for $f < f_c - 22 \text{ MHz}$ and $f > f_c + 22 \text{ MHz}$ where f_c is the channel center frequency. The transmit spectral mask is shown in Figure 98. The measurements shall be made using 100 KHz resolution bandwidth and a 30 KHz video bandwidth.

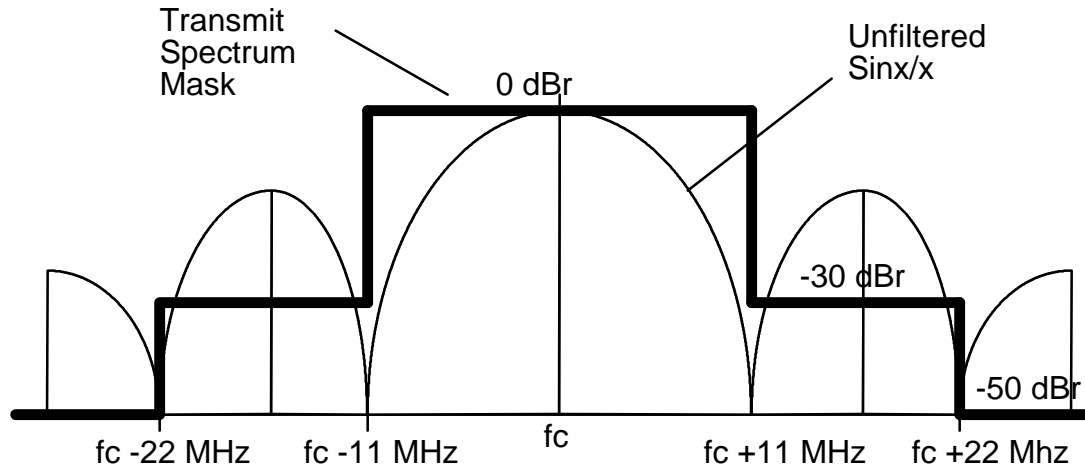

Figure 98, Transmit Spectrum Mask

1.4.7.5 Transmit Center Frequency Tolerance

The transmitted center frequency tolerance shall be +/- 25 ppm maximum.

1.4.7.6 Chip Clock Frequency Tolerance

The PN code chip clock frequency tolerance shall be better than +/- 25ppm maximum.

1.4.7.7 Transmit Power On and Power Down Ramp

The transmit power on ramp for 10% to 90% of maximum power shall be no greater than 2 μs . The transmit power on ramp is shown in Figure 99.

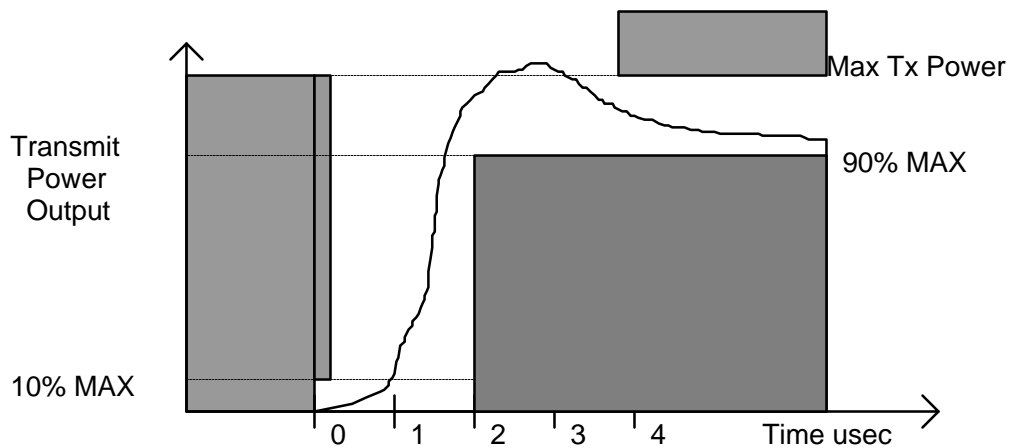

Figure 99, Transmit Power On Ramp

The transmit power down ramp for 90% to 10% maximum power shall be no greater than 2 μs . The transmit power down ramp is shown in Figure 100.

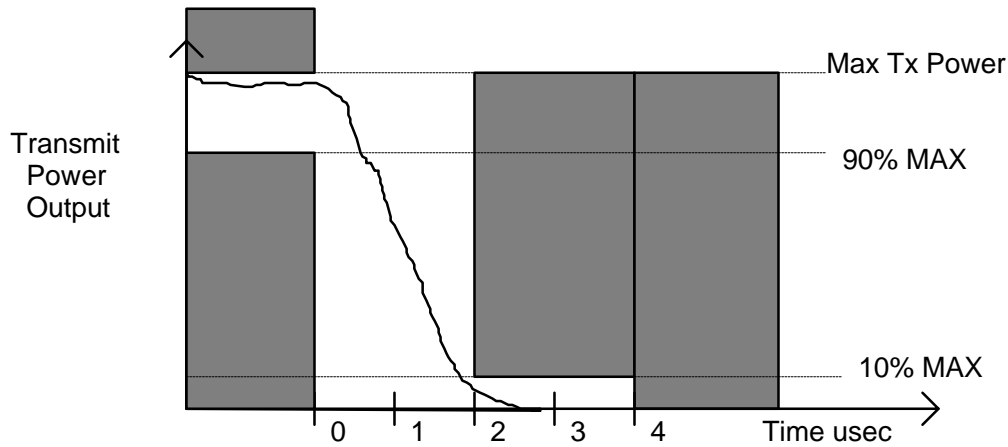

Figure 100, Transmit Power Down Ramp

The transmit power ramps shall be constructed such that the DSSS PHY emissions conform with spurious frequency product specification defined in clause 15.4.6.5.

1.4.7.8 RF Carrier Suppression

The RF carrier suppression, measured at the channel center frequency, shall be at least 15 dB below the peak $\text{SIN}(x)/x$ power spectrum. The RF carrier suppression shall be measured while transmitting a repetitive 01 data sequence with the scrambler disabled using DQPSK modulation. A 100 KHz resolution bandwidth shall be used to perform this measurement.

1.4.7.9 Transmit Modulation Accuracy

The transmit modulation accuracy requirement for the DSSS PHY shall be based on the difference between the actual transmitted waveform and the ideal signal waveform. Modulation accuracy shall be determined by measuring the peak vector error magnitude measured during each chip period. Worst case vector error magnitude shall not exceeded 0.35 for the normalized sampled chip data. The ideal complex I and Q constellation points associated with DQPSK modulation $(0.707, 0.707)$, $(0.707, -0.707)$, $(-0.707, 0.707)$, $(-0.707, -0.707)$ shall be used as the reference. These measurements shall be from baseband I and Q sampled data after recovery through a reference receiver system.

Figure 101 illustrates the ideal QPSK constellation points and range of worst case error specified for modulation accuracy.

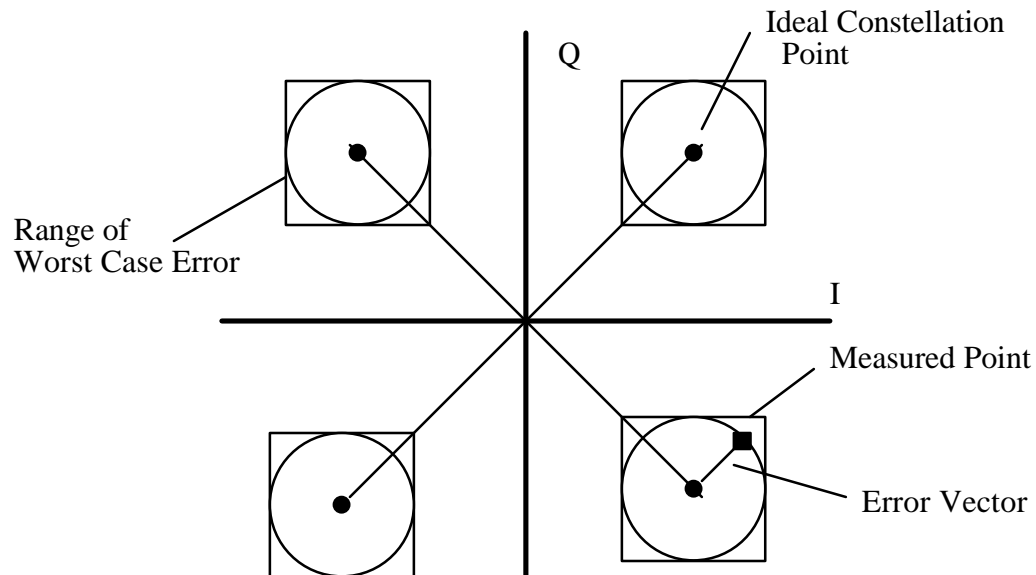

Figure 101, Modulation Accuracy Measurement Example

Error vector measurement requires a reference receiver capable of carrier lock. All measurements shall be made under carrier lock conditions. The distortion induced in the constellation by the reference receiver shall be calibrated and measured. The test data error vectors described below shall be corrected to compensate for the reference receiver distortion.

The 802.11 vendor compatible radio shall provide an exposed TX chip clock which shall be used to sample the I and Q outputs of the reference receiver.

The measurement shall be made under the conditions of continuous DQPSK transmission using scrambled all 1's.

The EYE pattern of the I channel shall be used to determine the I and Q sampling point. The chip clock provided by the vendor radio shall be time delayed such that the samples fall at a 1/2 chip period offset from the mean of the zero crossing positions of the EYE (see Figure 102 below). This is the ideal center of the EYE and may not be the point of maximum EYE OPENING.

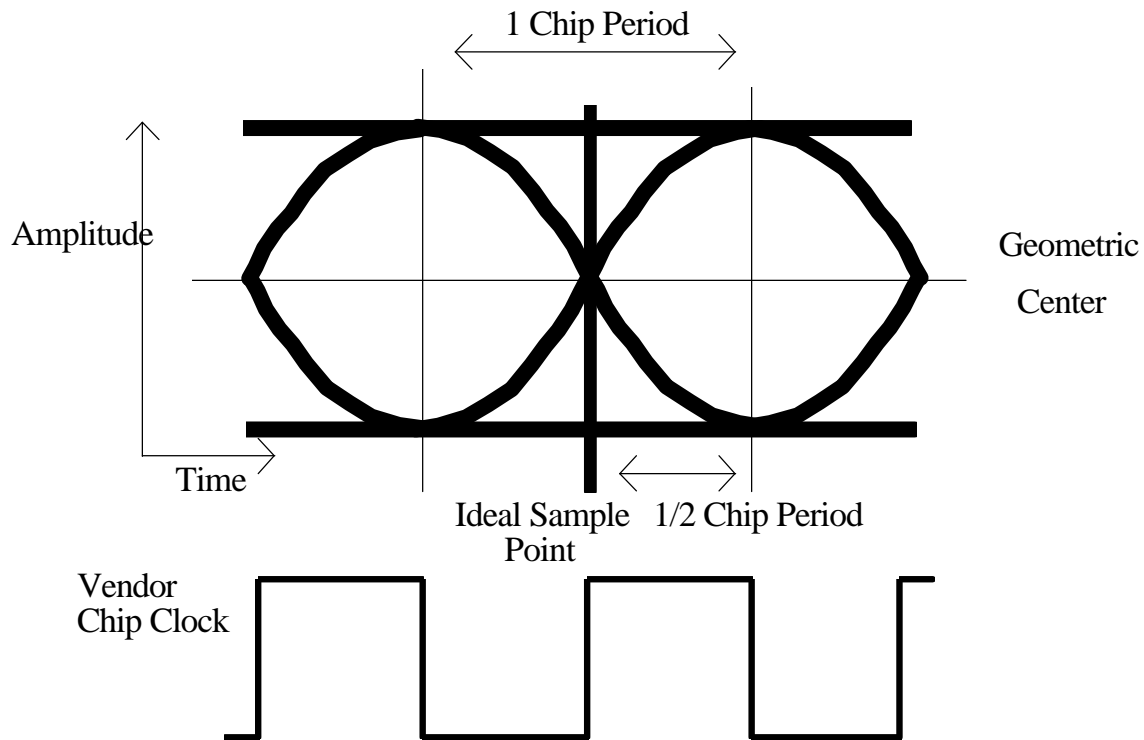

Figure 102, Chip Clock Alignment with Baseband Eye Pattern

Using the aligned chip clock, 1000 samples of the I and Q baseband outputs from the reference receiver are captured. The vector error magnitudes shall be calculated as follows:

Calculate the DC offsets for I and Q samples.

$$I_{\text{mean}} = \sum_{n=0}^{1000} I(n)/1000$$

$$Q_{\text{mean}} = \sum_{n=0}^{1000} Q(n)/1000$$

Calculate the DC corrected I and Q samples for all N =1000 sample pairs.

$$I_{\text{DC}}(n) = I(n) - I_{\text{mean}}$$

$$Q_{\text{DC}}(n) = Q(n) - Q_{\text{mean}}$$

Calculate the average magnitude of I and Q samples.

$$I_{\text{mag}} = \sum_{n=0}^{1000} |I_{\text{DC}}(n)|/1000$$

$$Q_{\text{mag}} = \sum_{n=0}^{1000} |Q_{\text{DC}}(n)|/1000$$

Calculate the normalized error vector magnitude for the $I_{\text{DC}}(n)/Q_{\text{DC}}(n)$ pairs.

$$V_{\text{ERR}}(n) = [1/2 \times ((|I_{\text{DC}}(n)|/ I_{\text{mag}})^2 + (|Q_{\text{DC}}(n)|/ Q_{\text{mag}})^2)]^{1/2} - V_{\text{CORRECTION}}$$

with $V_{\text{CORRECTION}}$ = error induced by the reference receiver system.

A vendor DSSS PHY implementation shall be compliant if for all N =1000 samples the following condition is met:

$$V_{\text{ERR}}(n) < 0.35$$

1.4.8 PMD Receiver Specifications

The following clauses describe the receive functions and parameters associated with the Physical Medium Dependent sublayer.

1.4.8.1 Receiver Minimum Input Level Sensitivity

The Frame Error Rate (FER) for 11 Mbit/s QMBOK modulation shall be less than 8×10^{-2} at an MPDU length of 1024 bytes for an input level of -80 dBm measured at the antenna connector. The test for the minimum input level sensitivity shall be conducted with the energy detection threshold set lower than or equal to -80 dBm.

1.4.8.2 Receiver Maximum Input Level

The receiver shall provide a maximum FER of 8×10^{-2} at an MPDU length of 1024 bytes for a maximum input level of -4 dBm measured at the antenna. This FER shall be specified for 11 Mbit/s QMBOK modulation.

1.4.8.3 Receiver Adjacent Channel Rejection

Adjacent channel rejection is defined between any two channels with greater than or equal to 30 MHz separation in each channel group defined in clause 15.4.6.2.

The adjacent channel rejection shall be equal to or better than 35 dB with an FER of 8×10^{-2} using 11 Mbit/s QMBOK modulation described in clause 15.4.6.4 and an MPDU length of 1024 bytes.

The adjacent channel rejection shall be measured using the following method:

Input a 11 Mbit/s QMBOK modulated signal at a level 6 dB greater than specified in clause 15.4.8.1. In an adjacent channel (greater than or equal to 30 MHz separation as defined by the channel numbering), input a signal modulated in a similar fashion which adheres to the transmit mask specified in clause 15.4.7.4 to a level 41 dB above the level specified in clause 15.4.8.1. The adjacent channel signal shall be derived from a separate signal source. It cannot be a frequency shifted version of the reference channel. Under these conditions, the FER shall be no worse than 8×10^{-2} .

1.4.8.4 Clear Channel Assessment

The DSSS PHY shall provide the capability to perform Clear Channel Assessment (CCA) according to at least one of the following three methods:

CCA Mode 1: Energy above threshold. CCA shall report a busy medium upon detecting any energy above the ED threshold.

CCA Mode 2: Carrier sense only. CCA shall report a busy medium only upon the detection of a DSSS signal. This signal may be above or below the ED threshold.

CCA Mode 3: Carrier sense with energy above threshold. CCA shall report a busy medium upon the detection of a DSSS signal with energy above the ED threshold.

The energy detection status shall be given by the PMD primitive, PMD_ED. The carrier sense status shall be given by PMD_CS. The status of PMD_ED and PMD_CS are used in the PLCP convergence procedure to indicate activity to the MAC through the PHY interface primitive PHYCCA.indicate.

A Busy channel shall be indicated by PHYCCA.indicate of class BUSY.

Clear Channel shall be indicated by PHYCCA.indicate of class IDLE.

The PHY MIB attribute aCCAModeSuprt shall indicate the appropriate operation modes. The PHY shall be configured through the PHY MIB attribute aCurrentCCAMode.

The CCA shall be TRUE if there is no energy detect or carrier sense. The CCA parameters are subject to the following criteria:

- a) The energy detection threshold shall be less than or equal to -80 dBm for TX power > 100 mW, -76 dBm for 50 mW < TX power <= 100 mW, and -70 dBm for TX power <= 50 mW.
- b) With a valid signal (according to the CCA mode of operation) present at the receiver antenna within 5 μ s of the start of a MAC slot boundary, the CCA indicator shall report channel busy before the end of the slot time. This implies that the CCA signal is available as an exposed test point. Refer to Figure 47 for a definition of slot time boundary definition.
- c) In the event that a correct PLCP Header is received, the DSSS PHY shall hold the CCA signal inactive (channel busy) for the full duration as indicated by the PLCP LENGTH field. Should a loss of carrier sense occur in the middle of reception, the CCA shall indicate a busy medium for the intended duration of the transmitted packet.

Conformance to DSSS PHY CCA shall be demonstrated by applying a DSSS compliant signal, above the appropriate ED threshold (a), such that all conditions described in (b) and (c) above are demonstrated.