

**Submission to
IEEE P802.11
Wireless LANs**

**Title: QMBOK Pulse Shaping for 2.4 GHz
Japanese Regulatory Requirements**

Date: May 1998

Author: Mark Webster and Carl Andren
Harris Semiconductor
mwebster@harris.com

Abstract

This submission tests the ability of the QMBOK modulation [1] to meet *the spread factor* test included in Japanese regulatory requirements. It is shown that the spread factor requirement can be met through moderate pulse-shape tailoring.

1. INTRODUCTION

This submission examines whether or not it is possible to meet the *spread factor* requirement for the QMBOK waveform [1]. Also, the ease or difficulty of meeting the spec with QMBOK is examined. An additional requirement of meeting the 30 dBr and 50 dBr spectral mask requirements of 802.11 DSSS is self-imposed as described in Table 1.1. This mask requirement may actually not be necessary for Japan because there is only one channel and no ACI requirement as such. If the mask requirement is loosened, meeting the spread factor is relatively easy.

Table 1.1 802.11 DSSS mask description.

Freq Separation from Carrier freq - fc	Mask
< 11 MHz	<= 0 dBr
> 11 MHz	<= -30 dBr
> 22 MHz	<= -50 dBr

The results are summarized in Table 1.1. The required spread factor is 10. A pulse shape which is 802.11 DSSS compliant may not meet the spread factor. This is demonstrated with an example. To solve this problem two different design extremes are examined—all-digital pulse shaping and all-analog pulse shaping. An actual design would probably be a mixture of digital and analog pulse shaping. Nevertheless, this memo illustrates the ease of satisfying the spec by using these two extremes to probe the boundaries of the problem.

Table 1.2 shows that the spread factor can be met with moderate pulse-shape tailoring.

Table 1.2 Summarized performance results.

SCENARIO	95% SPREAD FACTOR
Required Spread Factor	10
Conventional 802.11 Design	9.3
Digital Pulse Shaping Example	10.6
Analog Pulse Shaping Example	10.5

Section 2 of this submission attempts to define the spread factor requirement. Section 3 demonstrates that certain designs may fail the requirement. Section 4 shows that a digital-pulse design example which passes the spec. Section 5 shows an analog-pulse design example which passes the spec. Both of the successful design examples seem to illustrate that the spread factor spec can be met in a straight-forward fashion.

2. JAPANESE REGULATORY REQUIREMENTS

This section attempts to define the bandwidth requirement levied on spread spectrum systems communicating in the 2,471 to 2,487 MHz band in Japan. While other requirements must also be met, this submission deals only with the bandwidth requirement.

We cautiously delve into this topic because our interpretations may be in error. If we have failed to interpret the requirements correctly, we welcome correction. Our understanding is reflected in the following two statements:

- (1) The *spread factor* should be more than 10, where spread factor is defined as the ratio of spread bandwidth to the frequency which is equivalent to the symbol rate of information.
- (2) The *spread bandwidth* is defined as the frequency bandwidth of the upper and lower limit for which the average power of emission radiated at the frequency of more than its upper limit and of less than its lower limit is equivalent to 5% of the total average power emitted by the given radiation.

Some may interpret statement (2) as meaning 90% of the power must be contained within the *spread bandwidth*. Others feel a 95% interpretation is correct. If 95% is the wrong number, we welcome correction.

These interpretations are now used to quantify the requirements for the QMBOK signal. The QMBOK signal uses 8 Walsh signaling chips per symbol and a chip rate of 11 MHz to give a Walsh symbol rate of $11 \text{ MHz}/8 = 1.375 \text{ MHz}$. To meet the spread factor

requirement of 10, the transmit signal must have 95% (or 90%) of the power contained within a spectrum at least 13.75 MHz wide. This requirement is illustrated in Fig. 2.1.

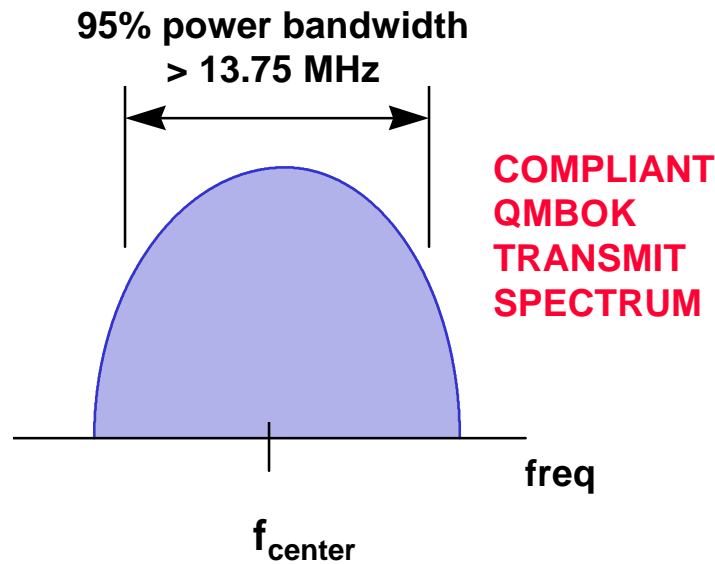

Figure 2.1 The compliant QMBOK signal must possess 95% (or 90%) of its power in a bandwidth equal-to or greater-than 13.75 MHz.

This interpretation is used in the following analyzes. The analysis measures the bandwidth for which 95% of the power is contained therein. If the 95% power bandwidth exceeds 13.75 MHz, it is believed the signal meets the spread factor requirement. The 90% numbers are also shown.

3. CONVENTIONAL NRZ PULSE

This section demonstrates that a pulse shape used for 802.11 DSSS 1-and-2 Mbps may not be adequate to meet the *spread factor* requirement in Japan. To do so two designs will be examined. The first design examines a standard NRZ pulse. This design passes the spread factor requirement. The second design will use a lowpass filter to limit the bandwidth of the NRZ pulse. This design fails the spread factor requirement. This submission (cf., section 4 and 5) identifies adequate pulse shaping techniques which eliminate the conventional NRZ pulse.

The first design uses an unfiltered NRZ pulse as shown in Fig. 3.1. The fundamental NRZ pulse shape imposes a $\sin x/x$ characteristic (sinc) as shown in Fig. 3.2. At the Nyquist chip bandwidth of 11 MHz, the spectrum has dropped to -3.9 dB. This spectrum obviously fails the 802.11 30 dB and 50 dB mask requirement.

The occupied power bandwidth is shown in Fig. 3.3. The 95% power point is at 35 MHz. This agrees with the rule that a little more than 90% of the power is in the sinc's mainlobe (22 MHz wide).

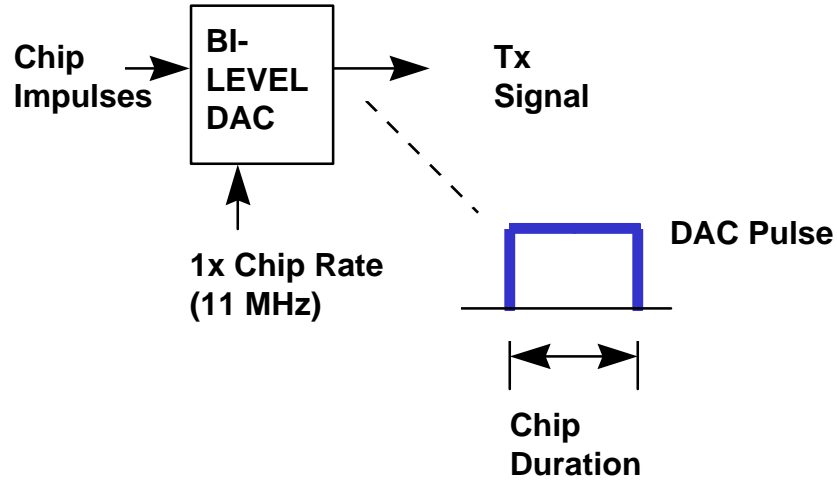

Figure 3.1 NRZ pulse design.

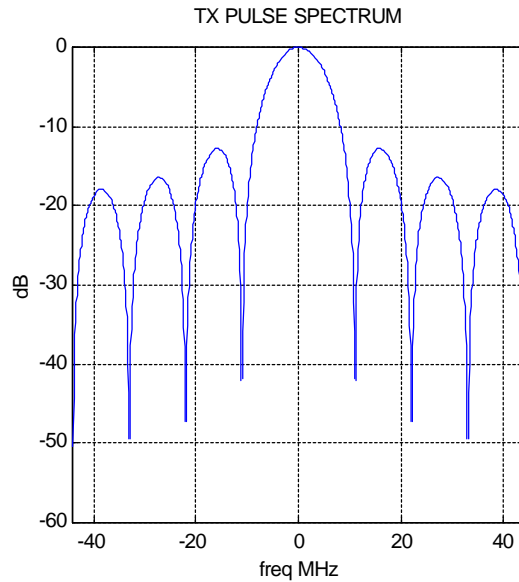

Figure 3.2 The sin x/x spectrum (sinc) generated by the NRZ pulse for Fig. 3.1.

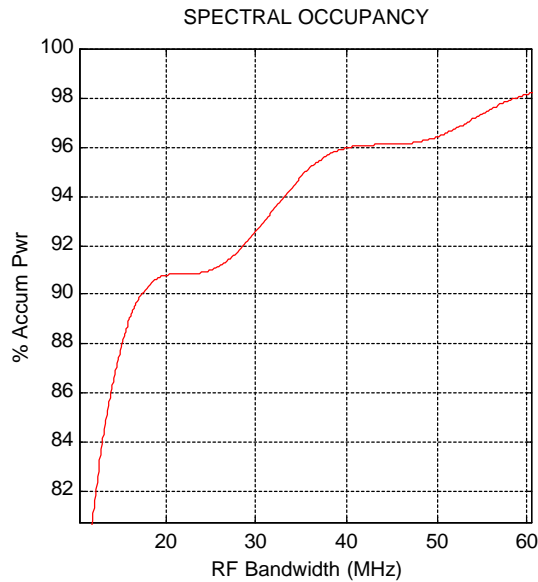

Figure 3.3 The power occupancy for the spectrum shown in Fig. 3.2. The 95% power bandwidth is about 35 MHz, much larger than the required minimum of 13.75 MHz.

Now it is shown that the addition of a lowpass filter to accommodate FDMA channel allocation causes a spread factor spec failure. The block diagram is shown in Fig. 3.4. The analog filter is specified as a 5th-order Butterworth with a one-sided bandwidth of 7.7 MHz (i.e., 70% mainlobe). The resulting spectrum is shown in Fig. 3.5, and the spectral occupancy is shown in Fig. 3.6.

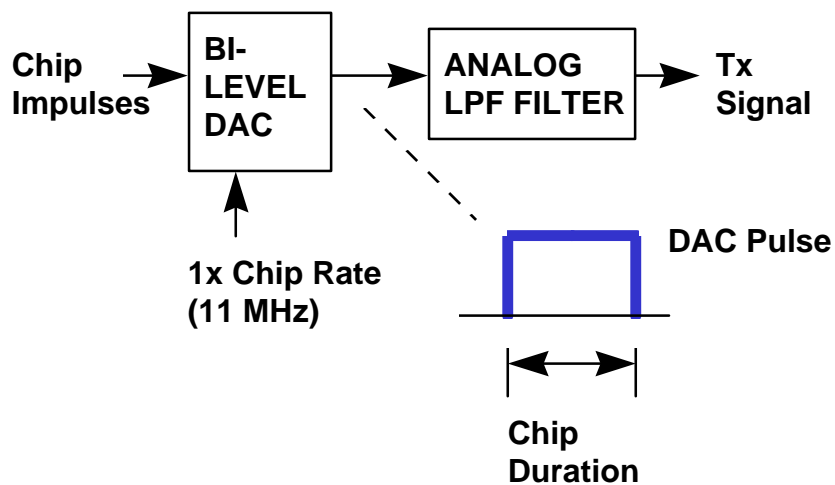

Figure 3.4 The design which uses a filtered NRZ pulse. This design is known to be 802.11 DSSS 1 and 2 Mbps compliant.

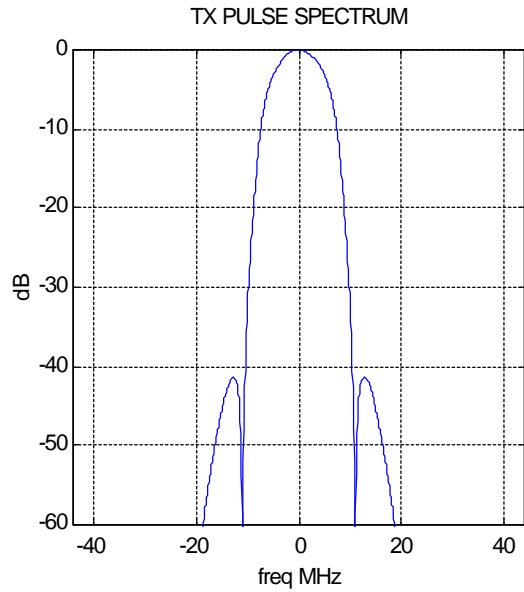

Figure 3.5 The spectrum resulting from filtering an NRZ pulse with a 5th-order Butterworth with a 3 dB one-sided bandwidth of 7.7 MHz (70% mainlobe).

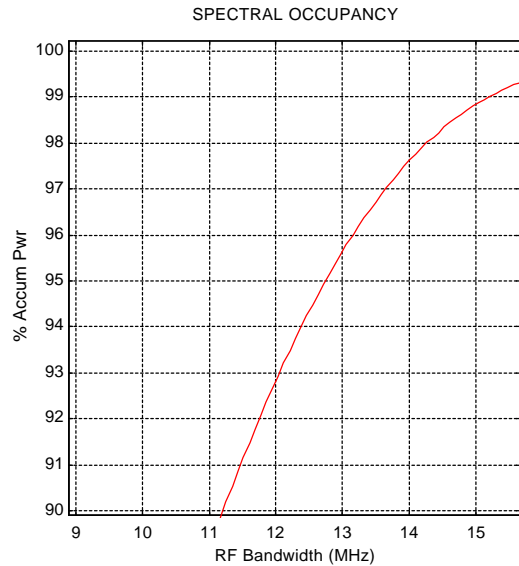

Figure 3.6 The spectral occupancy of the Butterworth-filtered NRZ pulse. It fails Japan's spread factor requirement because 95% of the power is contained within a bandwidth of only 12.8 MHz, less than the required bandwidth of 13.75 MHz.

Unfortunately, the 95% power bandwidth is only 12.8 MHz, less than the required minimum of 13.75 MHz. The good news is that the 95% power bandwidth is not very far

from 13.75 MHz, so the modifications to reach 13.75 MHz are probably not too difficult. This is shown to be true in the next couple of sections.

4. DIGITAL PULSE SHAPING

This section presents a digitally-shaped pulse design which appears to meet the spectral requirement. This is not the only design which meets the requirement, nor is it the recommended design. It is merely one design which illustrates the requirement can be met using all-digital pulse shaping.

The block diagram used in this section is shown in Fig. 4.1. It is assumed all the pulse shaping is performed in the digital FIR. This memo ignores the small amount of $\sin x/x$ weighting (sinc) placed on the spectrum by the DAC. Actually, one would have to include this effect in the overall design. This is easily accomplished using $\sin x/x$ compensation for a 4x rate DAC.

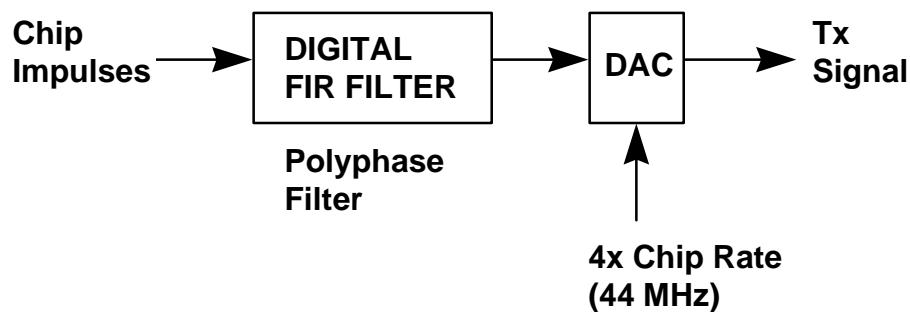

Figure 4.1 A block diagram of the pulse-shaping technique.

MATLAB was used to quickly design a pulse shape using 4 samples/chip. A snippet of the MATLAB code used in the analysis is shown in Fig. 4.2. An `fir1` design is a simple window-based lowpass filter design. A more exotic design, such as using the Parks-McClellan algorithm, was not attempted.

```

fSample = 4;
fCutoff = .75;
nTaps = 17;
fSample = 4;
wn = 2*fCutoff/fSample;
bTaps = fir1(nTaps,wn);
  
```

Figure 4.2 The MATLAB code used to create the FIR pulse-shaping filter.

A plot of the 18 generated FIR taps is shown in Fig. 4.3. The resulting spectrum is shown in Fig. 4.4. The spectrum meets the 802.11 30 dB mask and 50 dB mask. The signal design is ultra-conservative for the 50 dB requirement. The signal is much narrower than required at the 50 dB point.

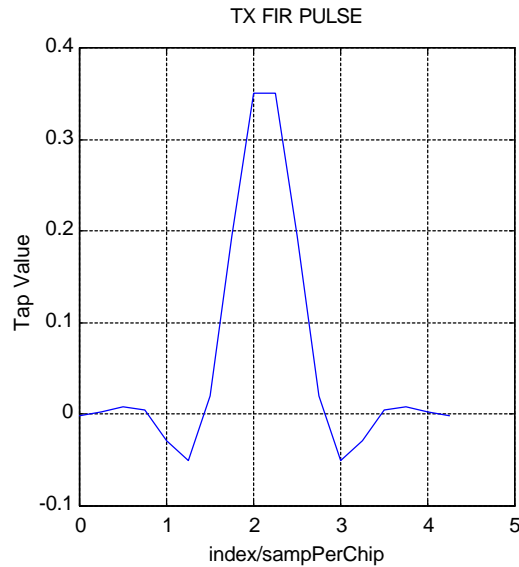

Figure 4.3 Impulse response of the digital FIR pulse-shaping filter.

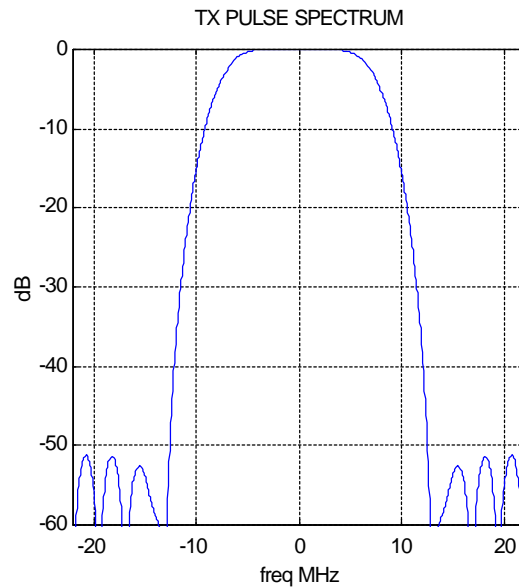

Figure 4.4 The spectrum produced by the FIR pulse of Fig. 4.3.

The transmit eye pattern is shown in Fig. 4.5 to demonstrate that the interchip interference is minimal. An equalizer or RAKE can easily handle this level of distortion.

The percent spectral occupancy for this design is shown in Fig. 4.6. Notice that the 95% power bandwidth is about 15.5 MHz, while the 90% power bandwidth is 90%. This is larger than the required 13.75 MHz.

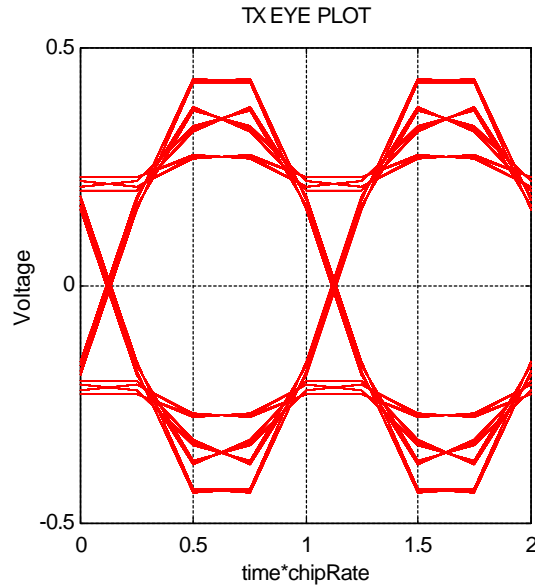

Figure 4.5 The transmit eye pattern created by the pulse of Fig. 4.3.

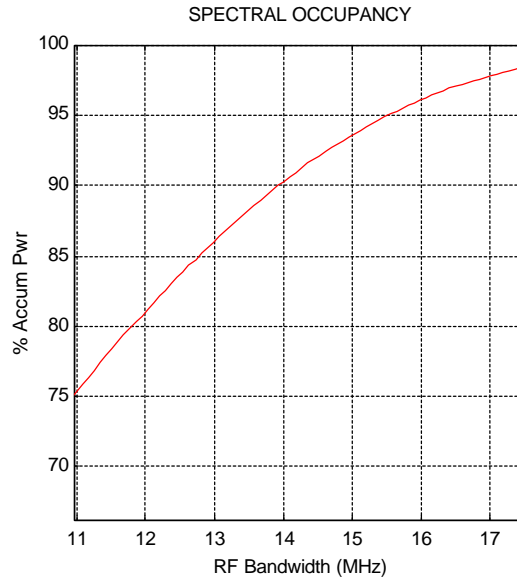

Figure 4.6 The measured power in the spectrum as a function of bandwidth. 95% of the power is within a bandwidth of 15.5 MHz. The 90% power bandwidth is 14 MHz. This exceeds the spread factor requirement of 13.75 MHz.

5. ANALOG PULSE SHAPING

This section presents an analog-shaped-pulse design which appears to meet the spectral requirement. This is not the only design which meets the requirement, nor is it the recommended design. It is merely one design which illustrates the requirement can be met using analog-intensive filtering.

The block diagram used in this section is shown in Fig. 5.1. It is assumed the pulse shaping is performed from the cascade of a tri-level DAC and a lowpass filter. The tri-level DAC is used to create a half-width NRZ pulse. Each chip consists of a half chip high-level followed by a half-chip zero level. The analog filter following the tri-level DAC removes digital images and shapes the skirt. By itself, the tri-level DAC creates a double-width sinc spectrum (mainlobe 44 MHz wide). Varying the width of the NRZ to other values than 50% was not attempted because a 50% width can be easily achieved using a 2x chip-rate clock (22 MHz).

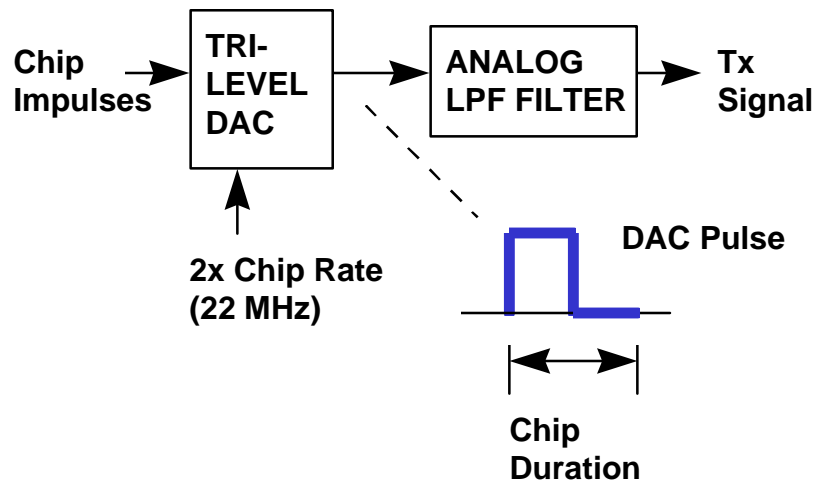

Figure 5.1 Analog filter intensive design. No FIR filter is used.

MATLAB was used to quickly design a half-NRZ pulse shape followed by a **CHEBY2** lowpass filter. A snippet of the MATLAB code used in the analysis is shown in Fig. 5.2. The **CHEBY2** lowpass filter is only 4th order.

```

% Parameters
fSample = 8;

% Shortened NRZ pulse
nrzHalf = ones(fSample/2,1);

% Choose LPF type
order = 4;
f3dB = 1;
wn = 2*f3dB/fSample;
[b,a] = cheby2(order,25,wn);
taps = impz(b,a);

```

Figure 5.2 The MATLAB code used to generate the half-width NRZ pulse and lowpass filter. The NRZ taps and CHEBY2 taps are convolved to form the composite response for analysis.

A plot of the composite impulse response is shown in Fig. 5.3. The resulting spectrum is shown in Fig. 5.4. The spectrum meets the 802.11 30 dB mask. The 802.11 50 dB mask can be met using a SAW.

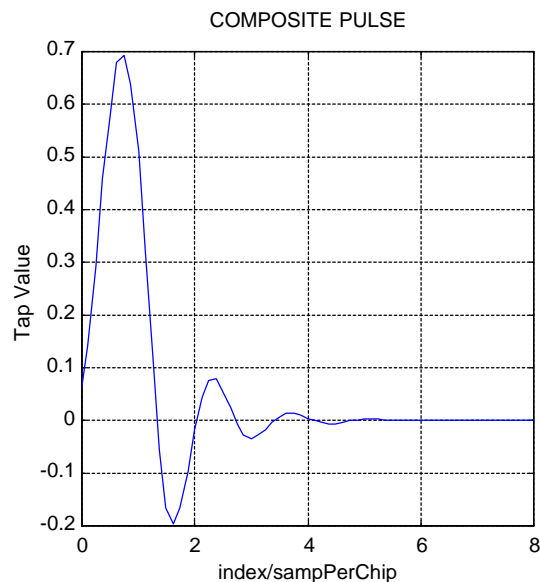

Figure 5.3 The pulse response of the half-NRZ and CHEBY2 cascade.

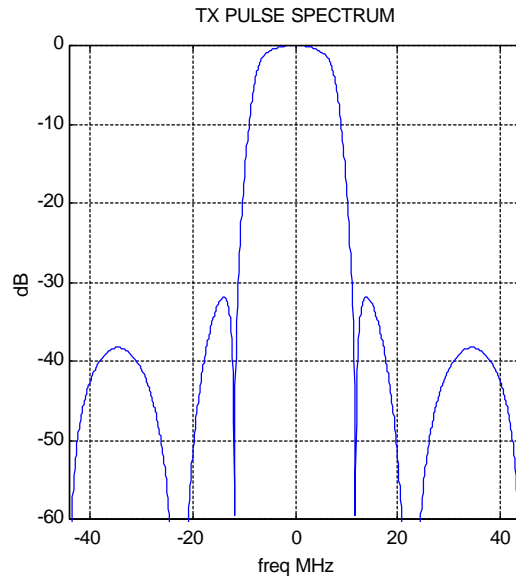

Figure 5.4 The pulse spectrum derived from the response shown in Fig. 5.3.

The transmit eye pattern is shown in Fig. 5.5 to demonstrate that the interchip interference is minimal. An equalizer or RAKE can easily handle this level of distortion.

The percent spectral occupancy for this design is shown in Fig. 5.6. Notice that the 95% power bandwidth is about 15.3 MHz. The 90% power bandwidth is 13.9 MHz. This is larger than the required 13.75 MHz.

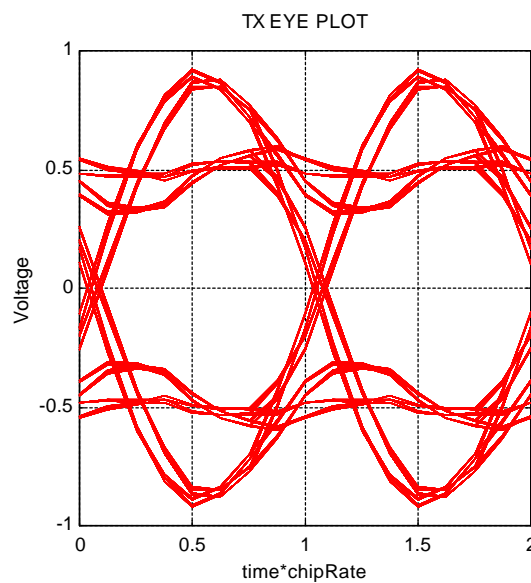

Figure 5.5 The transmit-signal eye closure using the suggested pulse.

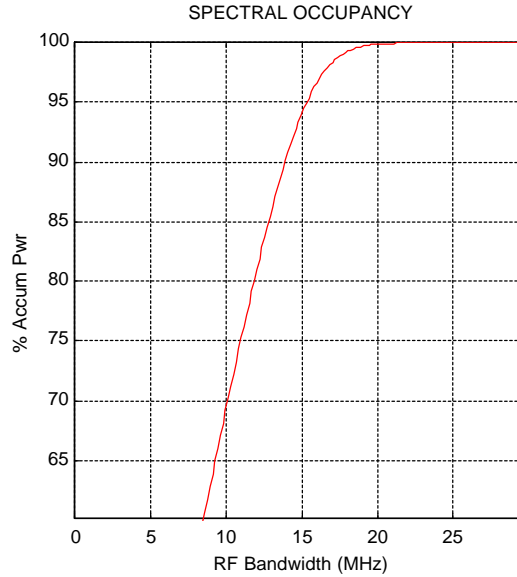

Figure 5.6 The spectral occupancy gained using the analog-filter intensive design. The 95% power bandwidth is about 15.3 MHz. The 90% power bandwidth is about 13.9 MHz. This is larger than the required 13.75 MHz.

6. CONCLUSION

The preceding results are summarized in Table 6.1. The required spread factor is 10. A pulse shape which is 802.11 DSSS compliant may not meet the spread factor. This was demonstrated with an example. To solve this problem two different design extremes were examined—all-digital pulse shaping and all-analog pulse shaping. An actual design would probably be a mixture of digital and analog pulse shaping. However, this memo has illustrated the ease of satisfying the spec by using these two extremes to probe the boundaries of the problem.

Table 6.1 Summarized performance results.

SCENARIO	95% SPREAD FACTOR
Required Spread Factor	10
Conventional 802.11 Design	9.3
Digital Pulse Shaping Example	10.6
Analog Pulse Shaping Example	10.5

REFERENCES

- [1] Carl Andren (HARRIS), "2.4 GHz High Rate PHY - Full Text," doc:IEEE P802.11-98/47, January 1998.