

Project	IEEE 802.16 Broadband Wireless Access Working Group < http://ieee802.org/16 >	
Title	CTS allocation for IBS and OBS	
Date Submitted	2006-02-28	
Source(s)	Wu Xuyong, Zhao Quanbo, Pan Zhong, Huawei Huawei Industrial Base, Bantian, Longgang, Shenzhen 518129 P.R.C	Voice: +86-755-28971677 Fax: +86-755-28975523 wuxuyong@huawei.com
Re:	80216h-06_005: Call for Comments and Contributions: IEEE 802.16 License-Exempt Task Group (2006-02-06)	
Abstract	ICTS is for the BSs which does not have repetitive scheduled CTS. OCTS is periodical scheduled to the BSs in community. This paper is discussion the usage, timing and scheduling method of these CTS.	
Purpose	Define the scheduling process and parameter of CTS in one community.	
Notice	This document has been prepared to assist IEEE 802.16. It is offered as a basis for discussion and is not binding on the contributing individual(s) or organization(s). The material in this document is subject to change in form and content after further study. The contributor(s) reserve(s) the right to add, amend or withdraw material contained herein.	
Release	The contributor grants a free, irrevocable license to the IEEE to incorporate material contained in this contribution, and any modifications thereof, in the creation of an IEEE Standards publication; to copyright in the IEEE's name any IEEE Standards publication even though it may include portions of this contribution; and at the IEEE's sole discretion to permit others to reproduce in whole or in part the resulting IEEE Standards publication. The contributor also acknowledges and accepts that this contribution may be made public by IEEE 802.16.	
Patent Policy and Procedures	The contributor is familiar with the IEEE 802.16 Patent Policy and Procedures < http://ieee802.org/16/ipr/patents/policy.html >, including the statement "IEEE standards may include the known use of patent(s), including patent applications, provided the IEEE receives assurance from the patent holder or applicant with respect to patents essential for compliance with both mandatory and optional portions of the standard." Early disclosure to the Working Group of patent information that might be relevant to the standard is essential to reduce the possibility for delays in the development process and increase the likelihood that the draft publication will be approved for publication. Please notify the Chair < mailto:chair@wirelessman.org > as early as possible, in written or electronic form, if patented technology (or technology under patent application) might be incorporated into a draft standard being developed within the IEEE 802.16 Working Group. The Chair will disclose this notification via the IEEE 802.16 web site < http://ieee802.org/16/ipr/patents/notices >.	

CTS allocation for IBS and OBS

Huawei Technologies Co., Ltd.

Overview

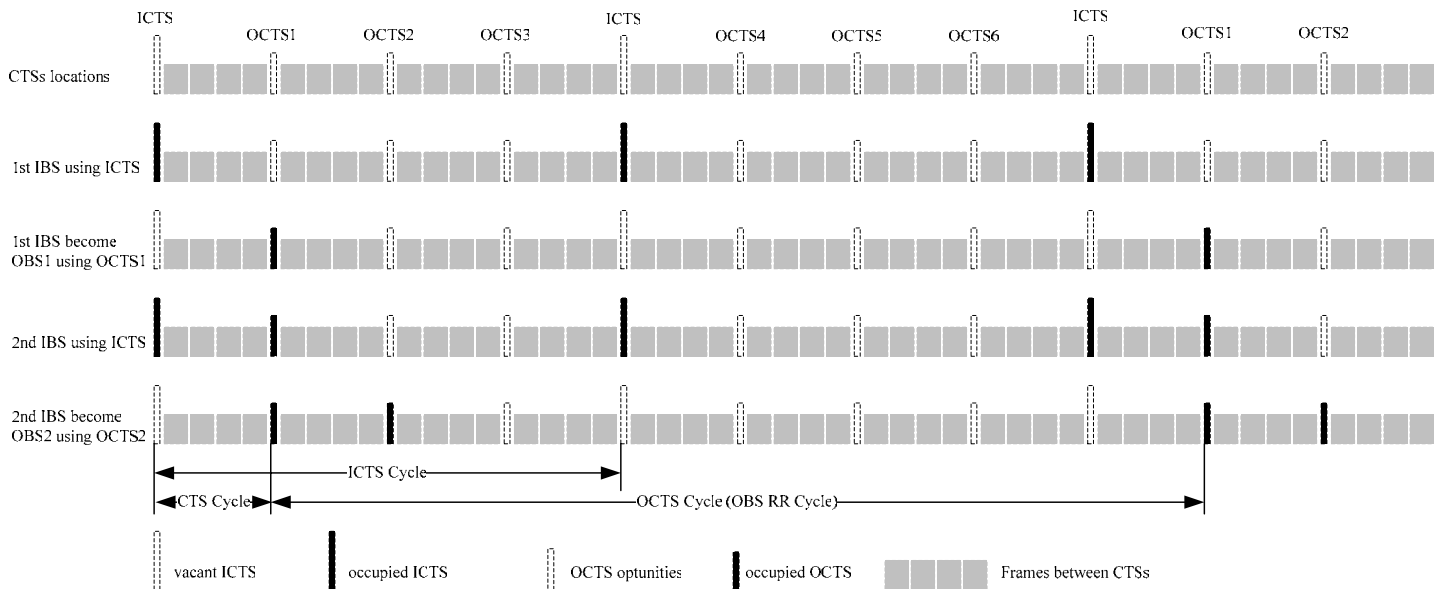

Coexistence Time Slot (CTS): a predefined time slot for the coexistence protocol signaling purpose, especially for the BS to contact its coexistence neighbor BS through one or more coexistence neighbor SAs in the common coverage area.

Initialization Coexistence Time Slot (ICTS): the periodically appointed CTS specially used by IBS to contact its neighbor OBS. When the IBS get the OCTS allocation and start the operating stage, it will ceased from using the ICTS.

Operation Coexistence Time Slot (OCTS): the rest CTS other than ICTS, periodically reallocated to OBSs.

Coexistence Time Slot Number (CTSN): the periodical number of CTS according to the time order. The range of CTSN is from 0 to the number of CTS in one OCTS cycle.

CTS parameters is unified in one community in all applicable channel:

- $T_{CTSstart}$: CTS starting time from the beginning of the frame (ms) [frame length - $T_{CTSdurat}$ - RTG length]
- $T_{CTSdurat}$: CTS duration time (ms) [set to max(10us, length of all the applicable symbol length) as default]
- $N_{CTSstart}$: CTS starting frame number frames [set to 0 as default]
- $N_{CTSintv}$: number of frames in CTS interval [set to 4 as default]
- N_{ICTS_Cycle} : ICTS cycle counted in CTS cycles [set to 4 as default]
- N_{OCTS_Cycle} : OCTS cycle counted in ICTS cycles [set to 4 as default]

Downlink CTS is use by the BSs to broadcast signaling to the neighbor systems. In order not to collide with the neighbor, the coordinated community should prevent neighbor BSs to use the same CTS.

In order to schedule the CTS, we need to arrange the CTS using CTSN, CTSN is periodical number of CTS, $CTSN = FN(\text{frame number of the frame after CTS}) / N_{CTS_{intv}} \bmod (N_{ICTS_Cycle} * N_{OCTS_Cycle})$. The period of CTSN is the length of OCTS cycle.

There was one ICTS for IBS in an ICTS cycle, and the rest CTS is leave to OBS as OCTS. Every OBS can get its OCTS allocation in one OCTS cycle, which is formed by multiple ICTS cycle so that IBS can get more opportunity then the OBS.

There is N_{OCTS_Cycle} ICTSs in one OCTS cycle, and the rest CTS could be allocated to $((N_{ICTS_Cycle} - 1) * N_{OCTS_Cycle})$ OBSs. Notice if there is N channel which could be used for 16h system in one area. There will be $N * ((N_{ICTS_Cycle} - 1) * N_{OCTS_Cycle})$ OCTS opportunity for OBSs.

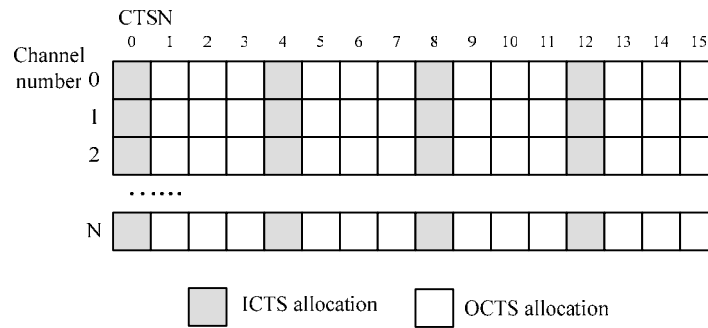

figure 1. format of ICTS/OCTS allocation MAP

In the initialization phase of a BS, before having it's own OCTS allocation, BS should use ICTS to advertise its arrival in the air at every candidate channels one by one., The neighbor OBS will then send their current OCTS allocation and current subframe allocation to the IBS using CP message. After IBS choose the working channel for its radio link, it shall pick a vacant CTSN for OCTS in this channel and tell all the neighbor the occupation. After that, this BS will start using this OCTS allocation as its exclusive CTS allocation.

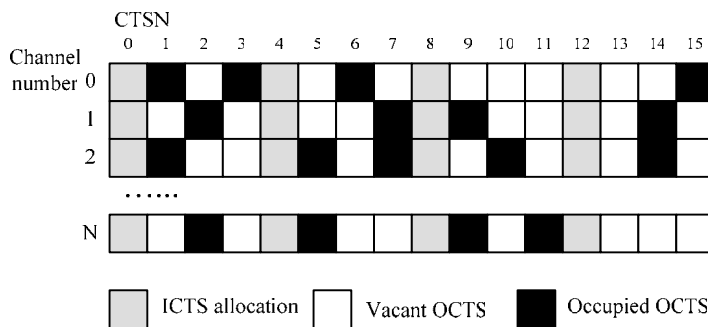

figure 2. example of CTS allocation MAP in one BS's database

Here is an example of the CTS allocation MAP of one BS during his initialization phase by collecting the CP message information from his neighbors. Assume this BS have choose channel 0 as its working channel, it can pick any one of the CTSN 2,5,7,9,10,11,13,14 as its OCTS allocation number. Every BS have its own CTS

allocation map indicating the current situation of CTS occupancy by the neighbors in the working channel and potential neighbors in the potential working channel. The CTS allocation MAP table of potential working channel will be used when BS move to another channel in cases. The CTS allocation MAP of the BS should be updated in time when any changes have been informed by its neighbors in the working channel and potential neighbors in the potential working channel.

By the mapping table of the OCTS allocations to the BSs, one BS can recognize the source of the interference or signaling in each OCTS allocation.

Reference:

- [1] *IEEE 802.16-06/004: Working Document for P802.16h (2006-02-06)*
- [2] *IEEE C802.16-06/017: CTS scheduling for IBS and OBS (2006-02-28)*

Proposal

Proposed text changes

Change section 15.3.1.1.1 as indicate:

15.3.1.1.1 Interference Identification & Resolution via CTS Detection

Downlink CTS is use by the BSs to broadcast signaling to the neighbor systems. These signals is used for Interference identification and resolution. In order not to collide with the neighbor, the coordinated community should prevent neighbor BSs to use the same CTS.

*CTSN is used to schedule the CTS in neighborhood, CTSN is periodical synchronized number of CTS. The period of CTSN is the length of OCTS cycle. $CTSN = FN(\text{frame number of the frame after CTS}) / N_{CTSinv} \text{ mod}(N_{ICTS_Cycle} * N_{OCTS_Cycle})$.*

There was one ICTS for IBS in an ICTS cycle, and the rest CTS is leave to OBS as OCTS. Every OBS need to get its OCTS allocation in one OCTS cycle, which is formed by multiple ICTS cycle so that IBS can get more opportunity then OBS.

*There is N_{OCTS_Cycle} ICTSs in one OCTS cycle, and the rest CTS could be allocated to $((N_{ICTS_Cycle} - 1) * N_{OCTS_Cycle})$ OBSs. Notice if there is N channel which could be used for 16h system in one area. There will be $N * ((N_{ICTS_Cycle} - 1) * N_{OCTS_Cycle})$ OCTS opportunity for OBSs.*

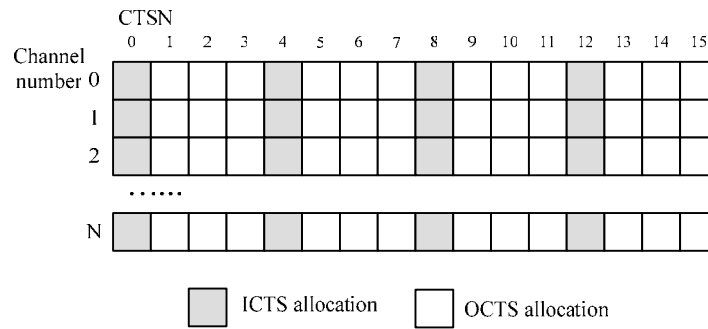

figure hxx. format of ICTS/OCTS allocation MAP

In the initialization phase of a BS, before having it's own OCTS allocation, BS should use ICTS to advertise its arrival in the air at every candidate channels one by one. The neighbor OBS will then send their current OCTS allocation and current subframe allocation to the IBS using CP message. After IBS choose the working channel for its radio link, it shall pick a vacant CTSN for OCTS in this channel and tell all the neighbor the occupation. After that, this BS will start using this OCTS allocation as its exclusive CTS allocation.

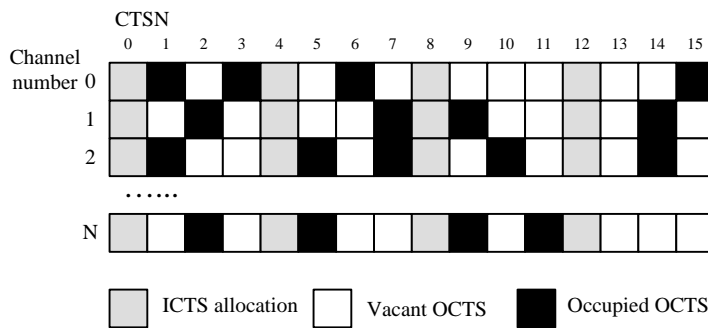

figure 2. example of CTS allocation MAP in one BS's database

Here is an example of the CTS allocation MAP of one BS during his initialization phase by collecting the CP message information from his neighbors. Assume this BS have choose channel 0 as its working channel, it can pick any one of the CTSN 2,5,7,9,10,11,13,14 as its OCTS allocation number. Every BS have its own CTS allocation map indicating the current situation of CTS occupancy by the neighbors in the working channel and potential neighbors in the potential working channel. The CTS allocation MAP table of potential working channel will be used when BS move to another channel in cases. The CTS allocation MAP of the BS should be updated in time when any changes have been informed by its neighbors in the working channel and potential neighbors in the potential working channel.

In the OCTS mapping table, every neighbor in working channel or potential neighbor in potential channel is mapped to one OCTS allocation, every OCTS allocation will indicate its occupant or vacancy. By inquiring the mapping table of the OCTS allocations to the BSs, one BS can recognize the source of the interference or signaling in each OCTS allocation.

The initializing BS use the OCTS allocation table to find out its neighbors in the working channel. By the contact information it acquired from the CP message, the IBS will than use CP message to negotiate for interference resolution with its neighbors.

Add the following section into clause 3. Definitions: (moved here from 15.2.1.1.3)

Coexistence Time Slot (CTS): a predefined time slot for the coexistence protocol signaling purpose, especially for the BS to contact its coexistence neighbor BS through one or more coexistence neighbor SSs in the common coverage area.

Initialization Coexistence Time Slot (ICTS): the periodically appointed CTS specially used by IBS to contact its neighbor OBS. When the IBS get the OCTS allocation and start the operating stage, it will ceased from using the ICTS.

Operation Coexistence Time Slot (OCTS): the rest CTS other than ICTS, periodically reallocated to OBSs.

Coexistence Time Slot Number (CTSN): the periodical number of CTS according to the time order. The range of CTSN is from 0 to the number of CTS in one OCTS cycle.

Add the following items into clause 4. Abbreviations and acronyms

ICTS	<i>Initialization Coexistence Time Slot</i>
OCTS	<i>Operation Coexistence Time Slot</i>
CTSN	<i>Coexistence Time Slot Number</i>

Change the section 15.2.1.1.3 as indicate:

15.2.1.1.3 Coexistence Time Slot

~~*CTS (Coexistence Time Slot): a predefined time slot for the coexistence protocol signaling purpose, especially for the BS to contact its coexistence neighbor BS through one or more coexistence neighbor SSs in the common coverage area.*~~

~~*ICTS(Initialization Coexistence Time Slot): the periodical appointed CTS specially used by IBS to contact its neighbor OBS. When the IBS get the OCTS allocation and start the operating stage, it will ceased to use the ICTS.*~~

~~*OCTS(Operation Coexistence Time Slot): the rest CTS other than ICTS, periodically reallocated to OBSs.*~~

~~*CTSN(Coexistence Time Slot Number): the periodical number of CTS according to the time order.*~~

CTS (Coexistence Time Slot) is predefined time slot for the coexistence protocol signaling purpose, especially for the BS to contact its coexistence neighbor BS through one or more coexistence neighbor SSs in the common coverage area. For the Initializing BS, periodical CTS called ICTS (Initializing Coexistence Time Slot) is appointed specially used by IBS to contact its neighbor OBS. Buy coordinate with other BS, the IBS will get its periodical OCTS (Operating Coexistence Time Slot) which is allocated only for this BS, and start the operating stage, hence ceased from using the ICTS.

Every CTS have its number, called CTSN (Coexistence Time Slot Number), that's a periodical number according to the time order.

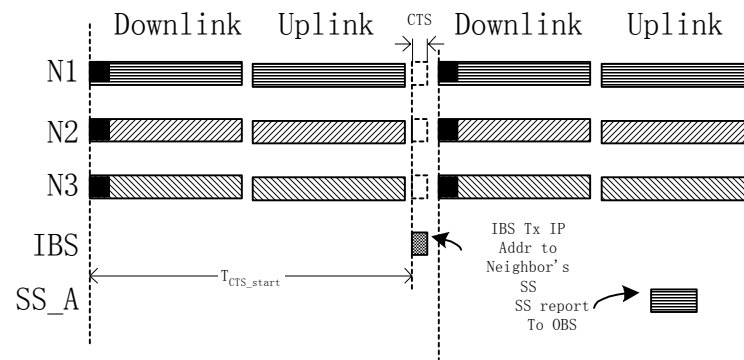

Figure h9—Timing of Coexistence Time Slot

~~ICTS must not be used for other purpose by all the BSs, so that it will be an interference free slot for the coexistence neighbor discovery purpose. Initializing BS (IBS) shall use this slot to broadcast its IP identifier, by sending a message and/or by cognitive radio signaling, so that the coexistence neighbor operating BS (OBS) could find the new coexistence neighbor in IP network after the SS report the message. Then the IBS and OBS begin further negotiation for coexistence protocol. After coordination with the neighbors in the community, IBS will get periodical interference free OCTSs, and become OBS, after that, it will cease to use the ICTS.~~

Not to break the downlink PDU, and to ~~prevent diminish~~ overhead of more preamble and gaps. CTS slots shall be located before RTG/TTG in TTD frame structure or before the preamble of downlink frame in FDD frame structure. To unify the location in these two kind of ~~frame duplexing frame~~, CTS slots in FDD frame shall be put into the downlink structure right before the preamble, and shall be located right before RTG in TDD frame.

~~The IBS_IPBC broadcasting procedure is unidirectional, only from the IBS to the SSs in IBS/OBS's common coverage, and the SSs shall report all the useful information to their OBSs they registered to. The SSs that succeed in receiving the message should report the IP address of IBS and the frame number of the starting frame of IBS_IPBC, the SSs failed to received the broadcasting message but got IBS_IPBC like interference in the ICTS should report the error status and the starting frame number of receiving the ICTS interference. By the IBS IP address reported from the SSs, the OBSs will then find the IBS in the IP network, and go further signaling using IP network. And by checking the frame number in the report, OBS need to find out if the SSs that report the error status in IBS_IPBC receiving have got the same interference source, then OBS will update the database and reply to the SSs which send the error report.~~

The CTS/ICTS parameters need to be unified in a particular region, and to be well known by the BSs. So that each BS could know the exact time to transmit the broadcasting message in its initialization. The parameters include:

- $T_{CTSstart}$: CTS starting time from the beginning of the frame (ms)
- $T_{CTSdurat}$: CTS duration time (ms)
- $N_{CTSstart}$: CTS starting frame number frames
- $N_{CTSintv}$: number of frames in CTS interval

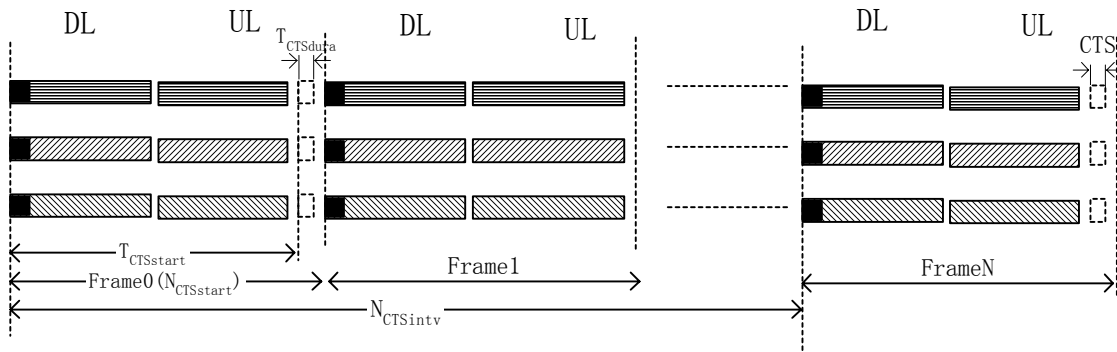
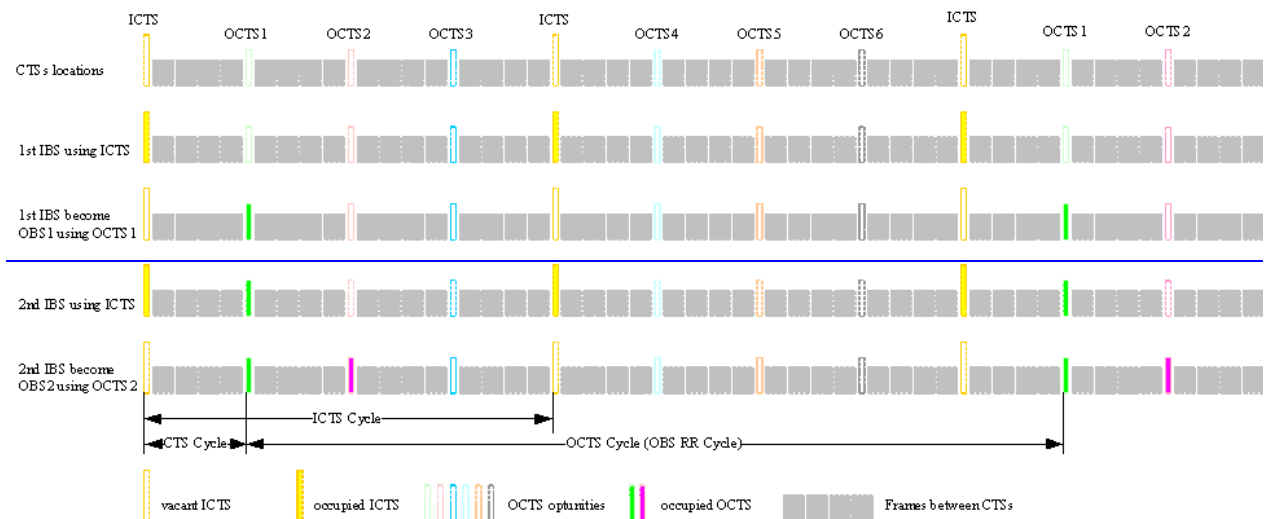

Figure h10—CTS parameters

- N_{ICTS_Cycle} : ICTS cycle counted in CTS cycles
- N_{OCTS_Cycle} : OCTS cycle counted in ICTS cycles

Assuming $N_{CTSintv} = 4$, $N_{ICTS_Cycle} = 4$, $N_{OCTS_Cycle} = 2$, here is the example of the timing indication:



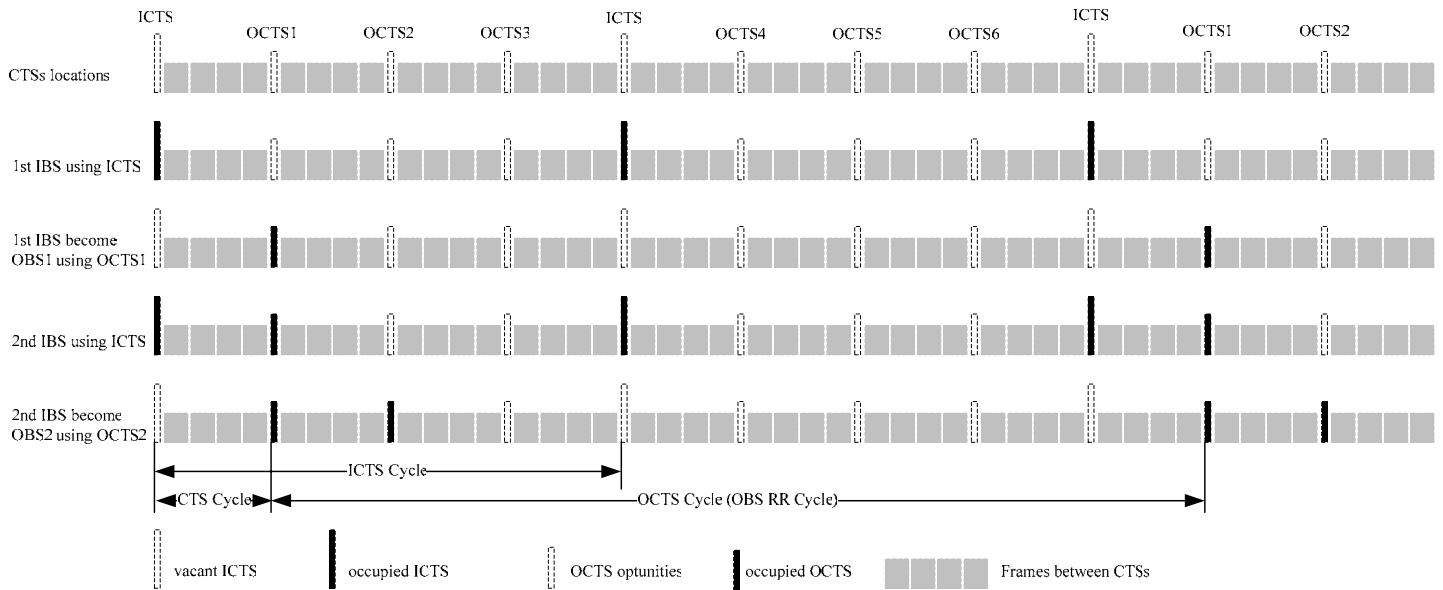

Figure h11—ICTS/OCTS occupation and timing example

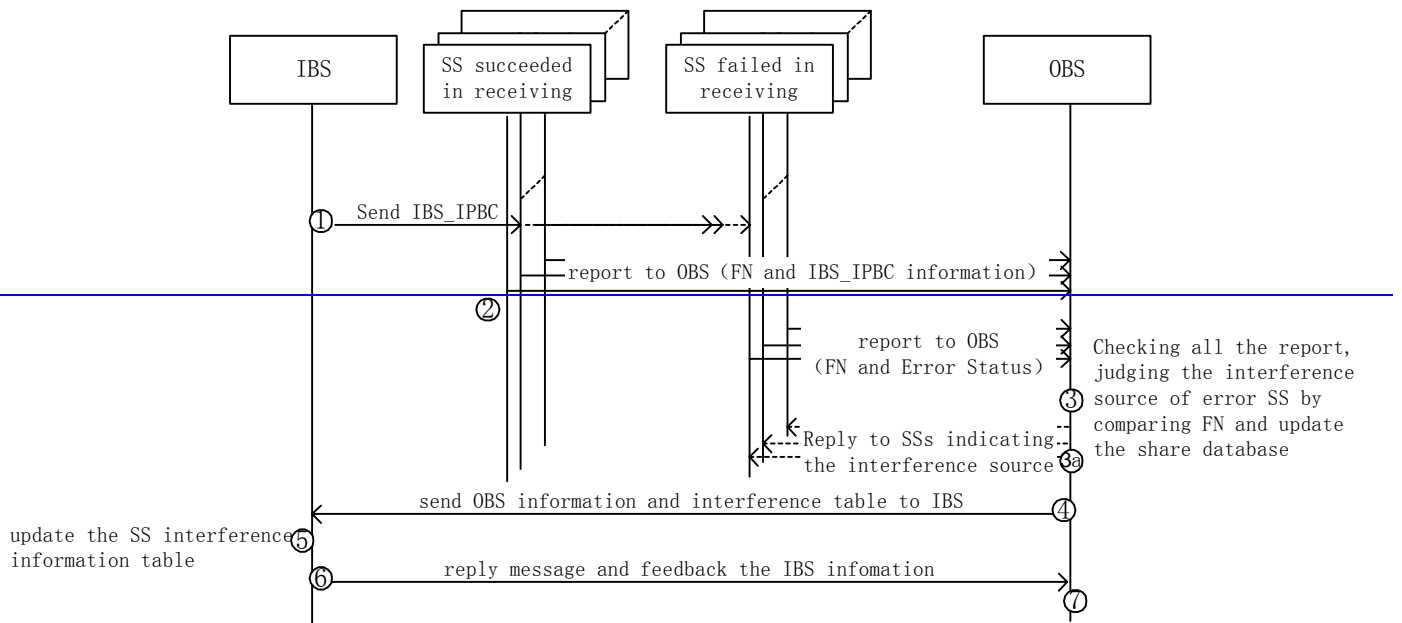

Figure h12—CTS usage example—IBS broadcast IP address to CoNBR's SS

[notes: this figure moves to 15.2.1.3]

[the following part of this section is taken from C802.16h-06 010r1, content below and above need to be harmonized.]

A coexistence time slot (CTS) is a reserved physical frame used for the coexistence protocol signaling purposes. For example, the beginning of the first CTS is at HH:MM:00 UTC, the second CTS is at HH:MM:06 UTC, etc. The beginning of every CTS slot is specified by a UTC message (time stamp). (**Error! Reference source not found.**)

The CTS could be used by ad hoc wireless LE systems (BSs and their SSs) to mediate their co-channel coexistence. The CTS will be an opportunity for systems (BSs and their SSs) to indicate to other systems (BSs and their SSs) the extent of the interference they can cause; newly arriving interfering base stations (IBS) will use the CTS to make themselves known to established communities of operating base stations (OBS). Newly entering SS will make their presence known when they are detected by base stations to which they are not associated (see Section[tbd.]). Sporadic interference from BS or SS will also be detected by the same process.

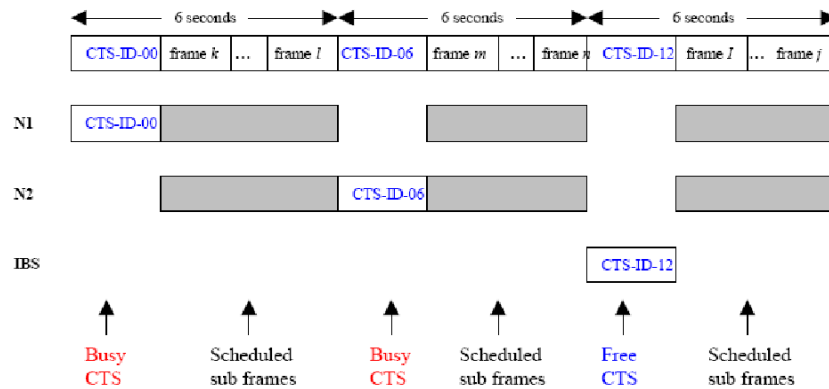

Figure h13—Alternative Timing of Coexistence Time Slot

Change Table h4 as indicate: (unique with C80216h-06_017)

Table h2—This BS information table

Syntax	Size	Notes
This BS information table(){		
BSID	48bits	
Operator ID	?bits	
<u>IP version</u>	<u>1bits</u>	<u>0-IPv4</u> <u>1-IPv6</u>
<u>If (IP version = 0){</u>		
<u> IPv4 address</u>	32bits	<u>IBS IPv4 address</u>
<u> CXPRX IPv4 address</u>	<u>32bits</u>	<u>CXPRX IPv4 address</u>
<u> }</u>		
<u>Else{</u>		
<u> IPv6 address</u>	<u>128bits</u>	<u>IBS IPv6 address</u>

CXPRX IPv6 address	128bits	CXPRX IPv6 address
1		
RTK	16 bits	Random Temporary Key
Extended Channel Number (ExChNr)	8bits	1 byte base reference to frequency range or deployment band. This reference maps to an absolute frequency value.
Extended Channel Number (ExChNr)	8bits	1 byte specific channel number reference
Channel spacing (ChSp)	16bits	2 bytes channel spacing value (10kHz increments)
Master resource ID	8bits	Sub-frame number
OCTS ID	8bits	CTSN of OCTS allocation
Negotiation status	8bits	Bit0: get communication in the IP network Bit1: be registered in Bit2: registered to Bit3: done for resource sharing(if neighboring) Bit4-7: tbc.
CTS parameter(){		Regulated by region/country
Tcts_start	16bits	In microseconds
Tcts_duration	8bits	In microseconds
Period of frames	8bits	frames
Starting frames offset	16bits	frame serial number of the first frame that CTS presented
Length of Symbols	8bits	In microseconds, need to be 1/n of Tcts_duration
ICTS cycle	8bits	ICTS cycle counted in CTS cycles
OCTS cycle	8bits	OCTS cycle counted in ICTS cycles
}		
Number of CoNBRs	8bits	m:The number of coexistence neighbors of this BS
for (i= 1; i <= m; i++) {		
BSID	48bits	
(Tbc.)	(Tbc.)	(Tbc.)
}		
Profile(){		
Band		
PHY mode(){		
Modulation		
(Tbc.)		
}		
Maximum power	8 bits	dbm

Number of registered SS	12bits	n
for (i = 1; i <= n; i++) {		
SSID	48bits	
(tbc.)	(tbc.)	(tbc.)
}		
(tbc.)	(tbc.)	(tbc.)
}		
}		

Table h3—BS information table

Syntax	Size	Notes
BS information table(){		
Index	16bits	
BSID	48bits	
Operator ID	?bits	
<u>RTK</u>	<u>16 bits</u>	<u>Random Temporary Key</u>
<u>IP version</u>	<u>1bits</u>	<u>0-IPv4</u> <u>1-IPv6</u>
<u>If (IP version = 0){</u>		
<u>CXPRX IPv4 address</u>	32bits	<u>CXPRX IPv4 address</u>
<u>}</u>		
<u>Else{</u>		
<u>CXPRX IPv6 address</u>	<u>128bits</u>	<u>CXPRX IPv6 address</u>
<u>}</u>		
Sector ID	8bits	
<u>Extended Channel Number (ExChNr)</u>	<u>8bits</u>	<u>1 byte base reference to frequency range or deployment band. This reference maps to an absolute frequency value.</u>
<u>Extended Channel Number (ExChNr)</u>	<u>8bits</u>	<u>1 byte specific channel number reference</u>
<u>Channel spacing (ChSp)</u>	<u>16bits</u>	<u>2 bytes channel spacing value (10kHz increments)</u>
Master resource ID	8bits	Sub-frame number
<u>OCTS ID</u>	<u>8bits</u>	<u>CTSN of OCTS allocation</u>
Negotiation status	8bits	Bit0: get communication in the IP network Bit1: be registered in Bit2: registered to Bit3: done for resource sharing(if coexistence neighboring) Bit4-7: tbc.

Coexistence neighboring	1bit	Coexistence neighbor with this BS? 1=yes 0=no
If (Coexistence neighbor){		
Number of victim SSs	16bits	n:The number of victim SSs of this coexistence neighbor, in this network
for (i = i; i <= n; i++) {		
SSID	48bits	
RSSI	16bits	1byte RSSI mean (see also 8.2.2, 8.3.9, 8.4.11) for details) 1byte standard deviation
}		
(Tbc.)	(Tbc.)	(Tbc.)
}		
Number of Coexistence neighbors	8bits	m:The number of coexistence neighbors of this BS
for (i= 1; i <= m; i++) {		
BSID	48bits	
(Tbc.)	(Tbc.)	(Tbc.)
}		
Profile(){		
Band		
PHY mode(){		
Modulation		
(Tbc.)		
}		
Maximum power	8 bits	dbm
Number of registered SS	12bits	
(tbc.)	(tbc.)	(tbc.)
}		
(tbc.)	(tbc.)	(tbc.)
}		

Table h4—SS information table

Syntax	Size	Notes
SS information table(){		
Index	16bits	
SSID	48bits	

Interference status	1bit	Interfered by coexistence neighbor? 1-yes 0-no
If (Interfered){		
Number of source BSs	8bits	n:The number of interference source of coexistence neighbor
for (i = 1; i<= n; i++) {		
BSID	48bits	
<u>IBS_IPBC-BS_NURBC</u> detected	1bits	1-yes 0-no
If (<u>IBS_IPBC-BS_NURBC</u> detected){		
<u>IP version</u>	1bits	0-IPv4 1-IPV6
If(IP version =0){		
<u>CXPRX IP address v4</u>	32bits	the v4 IP address of the CXPRX reported by the SS .If the IBS_IPBC message detected, the IP address report by the SS will add here, and updating the bit above
}		
Else{		
<u>CXPRX IP address v6</u>	128bits	the v6 IP address of the CXPRX reported by the SS
}		
<u>IBS BSID</u>	48bits	The BSID reported by SS
<u>RTK</u>	16bit	RTK in the BS_NURBC reported by SS
Sector ID	?bits	Reported by SS
Frame number	24bits	Reported by SS
Error Status	?bits	0 -no error 1 - not capable to decode the energy pulse symbol; 2 - not able to find the eligible <SOF>; 3 - not able to find the eligible <EOF>; 4 - not able to pass the CRC check for message;
(tbc.)	(tbc.)	(tbc.)
}		
RSSI	16bits	1byte RSSI mean (see also 8.2.2, 8.3.9, 8.4.11 for details) 1byte standard deviation
(tbc.)	(tbc.)	(tbc.)
}		
(tbc.)	(tbc.)	(tbc.)
}		
(tbc.)	(tbc.)	(tbc.)

