



Project	IEEE 802.16 Broadband Wireless Access Working Group < <a href="http://ieee802.org/16">http://ieee802.org/16</a> >	
Title	Action Items from Session #46: Definition of Interference Criteria	
Date Submitted	2007-01-17	
Source(s)	Avi Freedman Hexagon System Engineering 14 Imber st. Petach Tikva, Israel, 49001  Wu Xuyong Huawei, Huawei Industry Base, Bantian, Longgang, Shenzhen, China 518129	Voice: +972-3-9224420 Fax: +972-3-9224396 <a href="mailto:avif@hexagonltd.com">avif@hexagonltd.com</a>  <a href="mailto:wuxuyong@huawei.com">wuxuyong@huawei.com</a>
Re:	Working Group Letter Ballot #24 for IEEE P802.16h/D1.	
Abstract	This document contains proposed editorial and technical changes to clause 3 'Definitions'. A number of comments from Working Group Letter Ballot #24 considered at Session #46 suggested additions, deletions, and modification to this clause. This document addresses these comments and suggests a harmonization of these comments and presents accompanying editorial instruction to implement these changes.	
Purpose		
Notice	This document has been prepared to assist IEEE 802.16. It is offered as a basis for discussion and is not binding on the contributing individual(s) or organization(s). The material in this document is subject to change in form and content after further study. The contributor(s) reserve(s) the right to add, amend or withdraw material contained herein.	
Release	The contributor grants a free, irrevocable license to the IEEE to incorporate material contained in this contribution, and any modifications thereof, in the creation of an IEEE Standards publication; to copyright in the IEEE's name any IEEE Standards publication even though it may include portions of this contribution; and at the IEEE's sole discretion to permit others to reproduce in whole or in part the resulting IEEE Standards publication. The contributor also acknowledges and accepts that this contribution may be made public by IEEE 802.16.	
Patent Policy and Procedures	The contributor is familiar with the IEEE 802.16 Patent Policy and Procedures < <a href="http://ieee802.org/16/ipr/patents/policy.html">http://ieee802.org/16/ipr/patents/policy.html</a> >, including the statement "IEEE standards may include the known use of patent(s), including patent applications, provided the IEEE receives assurance from the patent holder or applicant with respect to patents essential for compliance with both mandatory and optional portions of the standard." Early disclosure to the Working Group of patent information that might be relevant to the standard is essential to reduce the possibility for delays in the development process and increase the likelihood that the draft publication will be approved for publication. Please notify the Chair < <a href="mailto:chair@wirelessman.org">mailto:chair@wirelessman.org</a> > as early as possible, in written or electronic form, if patented technology (or technology under patent application) might be incorporated into a draft standard being developed within the IEEE 802.16 Working Group. The Chair will disclose this notification via the IEEE 802.16 web site < <a href="http://ieee802.org/16/ipr/patents/notices">http://ieee802.org/16/ipr/patents/notices</a> >.	

## Action Item from Session #46: Definition of the interference Criteria

*Avi Freedman, Hexagon*

*Wu Xuyong, Huawei*

### Overview

This contribution addresses an action item assigned to the 1<sup>st</sup> author at Session #45 concerning the definition and application of interference criteria in [1]. This action item is related to contribution [2] presented at session #46, and the comments 15, 188, 210, 223, 227 and 276 from [3], and copied in the annex.

### Introduction

As stated in [2] and in comment 15, there is a need to define and standardize interference criteria. The purpose of those definitions would be to define threshold and trigger actions, as defined in the draft standard. In this document we present functional definitions of various interference criteria, define thresholds corresponding to these criteria, and suggest text changes in the draft to reflect this work.

### Approaches to Interference Ranges and Thresholds

There are two main approaches to describe the interference ranges and define the necessary thresholds.

#### *Functional approach*

One approach is from a functional point of view that describes the interference ranges according to the effect it has on a receiver. This approach is more suitable to define triggers and a common language to report interference levels:

One can identify 5 ranges of interference, as its power at the receiver grows:

**Non-harmful interference**, which does not impact the receiver. Interference might raise the noise level by some amount (and we follow here the common practice to assume that interference affects the receiver similar to noise of the same power and hence it is additive to noise). In [4], a small noise level rise, of 1dB was considered as a threshold for limiting the interference which is commensurate with the noise rise due to any type of interference. This type of interference should be taken into account for system planning and design in licensed bands.

**Light Interference**, which still does not impact the receiver as it is capable to operate with the same level of performance even if interference were not present. This is due to the fact that the signal to noise plus interference (SINR) is high enough. See Annex A for a deeper description and an example. It should be noted that for modern systems, such as OFDMA, which can use sub-channelization, even a small noise rise can lead to some loss of performance.

**Acceptable Interference**. As the systems covered in 16h, are supposed to work in non-exclusive bands, it is expected that they will be subject to interference that affects their performance. We suggest using capacity reduction as the measure for interference, and also standardizing the acceptable capacity reduction to be up to 66% of the interference-free capacity. This value of 66% results from the fact that we envision up to 3 systems

to share the same frequency channel in the same neighborhood. This number is also in accordance with the requirements on the frame size, latency requirement etc.

**Harmful Interference-** This is a strong interference which allows the link to communicate only by using its most robust mode of operation. In this mode, management messages can be communicated, but no traffic QoS can be assured. This is actually an interference that denies service, as understood by regulatory bodies.

**Destructive Interference** – This level of interference disables the victim to continue communicating by using any capable modulation.

The capacity reduction criterion mentioned above has implication on both the link and system level:

On the link level, this criterion implies interference level that reduces the effective signal to noise plus interference ratio such that the supported bit rate is reduced by 66%.

On the system level, this criterion implies a reduction of the system throughput to 1/3 of the interference-free level. This could happen if all the SS's of the system are subject to this level of interference, 2/3 of the SS's are subject to harmful interference or any other combination.

### ***Approach based on detection***

In addition to the functional approach we can use another one by which thresholds are defined according to the requirement imposed on the receiver to detect the existence of the interference signal and identify them, with a given false alarm rate and detection probability. Similarly, there are also the regulatory requirements to be taken into account. Thus we can define three other thresholds:

*Detection Threshold<sub>d</sub>*, which is defined as the threshold needed to detect the interference, with a given false alarm rate within a given amount of time, for the purpose of initiating an action within the system.

*Identification Threshold*, which is defined as the threshold needed to identify the interference source.

*Regulatory Threshold (DFS Threshold* in the standard but this applies to the very specific requirement of Radars in the 5GHz bands) as imposed by specific regulation.

## **Definition of interference and detection thresholds**

A threshold, in this document, is a signal or interference level (measured in dBm), at which an action is triggered.

### ***Functional approach***

A threshold is then set according to the boundaries between the interference ranges as defined above. We shall hereafter refer to a threshold by the range of the interference above it. Namely a *Light Interference Threshold* is the boundary between the **non-harmful interference** range and the **light interference** range. The *Acceptable Interference Threshold* is the boundary between the **light interference** range and the **acceptable interference** range. The *Harmful Interference Threshold* is the boundary between the **Acceptable interference** region and the **harmful interference** region, and the *Destructive Interference Threshold* is the threshold between the **harmful interference** range and the **destructive interference** range. For the 4 functional thresholds described above, the following values and considerations can be taken:

*Light Interference Threshold.* Typical numbers for the noise rise in licensed band is 0.5dB and 1dB. We suggest taking 1dB noise rise, which is translated to I/N level of -6dB. As this threshold depends on noise only it can be defined on absolute terms. A signal weaker than this threshold is not considered to be an interfering signal and should not be reported. A stronger interference signal may be reported. This concept is supported by

a primary IEEE802.16 official recommendation document IEEE802.16.2-2004 [4], section 7.2.1, the first recommendation in chapter 7. Coexistence of FBWA systems operating in 2–11 GHz licensed bands. (page69)

*Acceptable Interference Threshold.* The threshold value above which the interference already impacts the receiver performance, highly depends on the SINR of the victim receiver and its capabilities. An OFDMA receiver with a large set of modulation and coding states can better exploit the extra signal strength than a simpler receiver, but then it will be more vulnerable to interference.

*Harmful Interference Threshold.* The threshold, above which the interference cannot be considered to be acceptable, depends highly on the received signal strength and system capabilities and should be expressed in terms of the SINR. The BS should in fact associate an appropriate level to each burst profile. It also depends upon the number of subchannels associated to an SS.

*Destructive Interference Threshold.* The level of harmful interference is also dependent on the actual received signal strength and system capabilities and expressed in terms of the SINR. This level of interference must be reported and action be taken to avoid it.

### ***Approach based on detection***

The approach, in which we define *Detection*, *Identification* and *Regulatory Threshold*, assumes that the receiver devotes resources for measurements and detection, which the system has to allocate according to the requirements.

The *Detection Threshold* and the *Identification Threshold* should be defined according to detection and estimation theory. Namely, for the detection threshold a set of probability of detection and probability of false alarm should be defined, for a given interval of time allocated for detection by the system.

Similarly, *Identification Threshold* should be defined according to the probability of positive identification at a given probability of error (no or false identification), at a given interval of time.

The actual signal levels of each of those thresholds highly depend on the system parameters (bandwidth, antenna system, etc.), the detection and identification scenarios and the algorithm applied in the receiver. As those algorithms are outside the scope of the standard, we suggest to define those thresholds in terms of the operational requirements, namely define the minimum required probability of detection and maximum allowed probability of false alarm at a given measurement time (or frequency) window.

As for the *Regulatory (DFS) Threshold*, the standard itself has the following indications for the regulatory requirement: In section 6.3.15.1 (802.16e) it is mentioned that the level of this threshold for primary users' detection is determined by the different regulatory requirements. On the other hand chapter 12 spells out two numbers: -65dbm, for the 10MHz OFDM profile (12.3.2.6) and -61dBm for the Wireless HUMAN OFDMA profiles (12.4.3.1.4). The regulatory requirements are stated in Annex B of [1]. Those numbers are by far higher than the minimal detectable level of the signals and that required to merely detecting the presence of a signal. Presumably, those numbers were set under the assumption that only when such high signals are measured by the 802.16 device, then the level received by the primary user will interfere with it.

{As a note, we should add that the particular method used to detect primary users is declared outside the scope of the current standard (see 6.3.15.4)}

The actual threshold used for detection of a specific signal should be determined according to the following procedure:

1. The interference level at the receiver at normal operation should be determined.
2. The signal level which is set as the threshold is then determined according to the required probability of detection and probability of false alarm, at the time allocated for measurement.

## Brief Summary of proposed changes in the document

**Comment 15** requires the introduction of appropriate definitions and a review of the usage of the word thresholds in the document. The document contains 25 occurrences of the word "threshold". In the following table we make a suggestion to which level each particular threshold refers to. Only relevant occurrences appear in the table.

Page	Section	Type of threshold	Suggested type of threshold to use
8	6.3.2.3.33	Threshold of interference measurement in the REP-RSP message	All types, depending on the report
15	6.3.2.3.67	DFS threshold. The level for which radar signals should be reported.	Basically the <i>DFS (Regulatory)</i> . The system might require a lower threshold in order to be aware of the signal existence.
15	6.3.2.3.67	Detection threshold of interference events reported by the BS-CCID-IND message in the INT_BSD_frq variable	<i>Detection</i> Note this threshold is adjustable so it doesn't have to be defined. No change necessary.
16	6.3.2.3.68	RSSI power threshold adjustment range	There is a TBD in the table that should be removed. If the lowest level of the threshold should be indeed the <i>Light Interference</i> threshold, the lowest level should be given as a function of the bandwidth and not as a number. However, there are 7 bits allocated with 0.5 dB resolution, it can cover 64 dB. So, absolute levels can be given
16	6.3.2.3.68	TBD threshold of the number of interference events per CMI cycle	<i>Detection threshold</i> Related to the probability of detection and probability of false alarm required. No change was made now
21	6.4.2.3.2	A threshold for DCS (for interference from non SSU)	<i>Acceptable interference threshold</i>
24	6.4.3.3	The threshold for report within the EQP	<i>Detection threshold</i>
26	6.4.3.5	Within Fig. h7, the threshold for LBT	<i>Detection Threshold</i>
38	15.1.1	The threshold defining neighbor relationships	<i>Light Interference Threshold</i>
40	15.1.1	The threshold defining neighbor relationships	<i>Light Interference Threshold</i>
63	15.2.2	The threshold by which an IBS determines if a channel has interference	<i>Light Interference Threshold</i> . However, the procedures might be changed to enable the IBS to preferred less interfered channels.

As currently only *Detection, Regulatory, Light and Acceptable Interference Thresholds* are used, definitions were given only to those thresholds.

Contribution C802.16h-06/111, mentioned in comment 15, also requires that same threshold criteria (detection threshold) would apply for Energy Keying. However, as the Energy keying issue is subject to revision, we did not offer any specific text changes for that.

**Comment 188** requires that the interference criteria are defined. This is actually the output of this document.

**Comment 210** requires defining the meaning of "In signaling/ messaging range" appearing in the title of Table h3. As this is only a descriptive title, there is no point in defining thresholds for that. Recommendation: reject the comment

**Comment 223** requires giving a more specific definition of "Interference free slots" within the initialization stage procedure described in section 15.1.3.1. Wording is offered by this document.

**Comment 227** refers to the optimization of channel distribution procedure, as referred to in section 15.1.3.1, however, the changes it requires should be made in section 15.4.1.1, as section 15.1.3.1 is descriptive. A reference was added to section 15.1.3.1. Section 15.4.1.1 includes already a reference to the information table in the distributed database, where the relevant channels appear. We do not think that any more specification is necessary.

**Comment 276** refers to the statement "No system is allowed to create harmful interference to a system owning a Master sub-frame" in section 15.1.5.1. The intention of the original sentence was that the allowed interference level is such that service, of acceptable level, can still be provided to the terminals of the master system. While "acceptable" depends actually on the requirement of the terminal user, we suggest using here "light interference" as defined above. New wording is suggested for this fact. As this is a descriptive paragraph, no further text is necessary.

## Specific editorial changes

This section provides a list of changes to IEEE P802.16.D1 [1].

Blue underlined text represents specific editorial additions.

~~Red strikethrough~~ text is to be deleted.

Black text is text already in the draft.

***Bold italic*** text is editorial instructions to the editor.

### ***General editorial instruction:***

***Reorder the definitions in clause 3 into alphabetical order and modify the sub clause numbering accordingly.***

***Make the following entries into clause 3 'Definitions':***

### 3. Definitions

**3.x1 Non-harmful interference range**, An interference signal is within this range when it is lower than 6dB below noise level, ~~as set in IEEE 802.16.2-2004 and similar standards.~~

**3.x2 Light Interference**, An interference signal is within this range if it does not impact a given receiver operating with a given signal to noise plus interference ratio and having a given set of capabilities.

**3.x3 Acceptable Interference**. An interference signal is within this range if its impact on a given receiver operating with a given signal to noise plus interference ratio and having a given set of capabilities reduces its capacity by no more than 66% of the interference-free capacity.

**3.x4 Harmful Interference-** An interference signal is within this range if it denies service from the receiver and allows communication only by its most robust mode of operation.

**3.x5 Destructive Interference** – An interference signal is within this range if it disables the victim to continue communicating by using any capable modulation.

**3.x6: Detection Threshold** A value (in dBm) of a signal level, above which a signal is determined to exist in a certain probability (probability of detection) with a given false alarm rate and within a given amount of time, for the purpose of initiating an action within the system.

**3.x7: Regulatory Threshold** A value (in dBm) of a signal level, as defined by the regulatory body, above which the receiver has to initiate an action.

**3.x8: Light Interference Threshold:** A value (in dBm) of a signal level, above which a signal is defined as being within the *Light Interference* range.

**3.x9: Acceptable Interference Threshold:** A value (in dBm) of a signal level, above which a signal is defined as being within the *Acceptable Interference* range.

#### 6.3.2.3.33 Channel measurement Report Request/Response (REP-REQ/RSP)

##### **Comment 15**

*Insert in p.8 line 30*

The following threshold levels will be used for the report:

- For specific signals mandated by regulation: the *regulatory threshold*
- For non SSU's: *light interference threshold* (translated into a *detection threshold*, for the relevant measurement interval, with probability of detection of 90% and probability of false alarm  $10^{-4}$ ).

#### 6.3.2.3.67 BS\_CCID\_IND message

##### **Comment 15**

*Change in p.15 line 30*

Radar signals may be detected at below ~~DFS~~ *Regulatory threshold* values

### 6.3.2.3.68 BS\_CCID\_RSP message

#### Comment 15

Change in p.16 line 30 3<sup>rd</sup> column of Table 108ag

Bit 3-9:

Interference RSSI Power threshold

Adjust ~~(-95 to -55 dBm (TBD) -120 to -56 dBm, 0.5 dB resolution)~~. (John to fix the table)

### 6.4.2.3.2 Dynamic Channel Selection (DCS)

#### Comment 15

Change in p.21 line 39

Once a logical channel unusable due to prevailing interference that has surpassed ~~a predetermined~~ the acceptable harmful interference threshold or degraded the BER sufficiently,...

### 6.4.3.3 Extended Quiet Periods (EQP)

#### Comment 15

Change in p.24 line 6

They will transmit a corresponding REP-RSP message if a measurement detected activity above the detection threshold for the frequency band of operation.

### 6.4.3.5 Listen-Before-Talk

#### Comment 15

Change in p.26 line 32 within Fig. h7

Energy detect above detection threshold or positive ID of another user

## 15.1 General

### Comment 15

Add in p. 38 l.6

The effect of interference on a victim receiver depends on many factors such as the power of the wanted signal received by the receiver, the receiver capabilities and its user's requirement and services. One can identify 5 ranges of interference, as its power at the receiver grows:

**Non-harmful interference**, which does not impact the receiver. Interference might raise the noise level by some amount (and we follow here the common practice to assume that interference affects the receiver similar to noise of the same power and hence it is additive to noise). In IEEE 802.16.2™ -2004, a small noise level rise, of 1dB was considered as a threshold for limiting the interference which is commensurate with the noise rise due to any type of interference. This type of interference should be taken into account for system planning and design in licensed bands.

**Light Interference**, which still does not impact the receiver as it is capable to operate with the same level of performance even if interference were not present. This is due to the fact that the signal to noise plus interference (SINR) is high enough. See Annex A for a deeper description and an example. It should be noted that for modern systems, such as OFDMA, which can use sub-channelization, even a small noise rise can lead to some loss of performance.



**Acceptable Interference.** As the systems covered in this clause, are supposed to work in non-exclusive bands, it is expected that they will be subject to interference that affects their performance. We suggest using capacity reduction as the measure for interference, and also standardizing the acceptable capacity reduction to be up to 66% of the interference-free capacity. This value of 66% results from the fact that we envision up to 3 systems to share the same frequency channel in the same neighborhood. This number is also in accordance with the requirements on the frame size, latency requirement etc.

**Harmful Interference-** This is a strong interference which allows the link to communicate only by using its most robust mode of operation. In this mode, management messages can be communicated, but no traffic QoS can be assured. This is actually an interference that denies service, as understood by regulatory bodies.

**Destructive Interference** – This level of interference disables the victim to continue communicating by using any capable modulation.

A threshold, in this document, is a signal or interference level (measured in dBm), at which an action, such as a report or coordination, is triggered.

Thresholds are defined as the boundaries between the levels mentioned above. The following thresholds were defined for different actions:

*Light Interference Threshold.* – is the boundary between the non-harmful interference range and the light interference range. This threshold is defined as a noise rise of 1db, which corresponds to an interference signal of interference to noise ratio  $I/N = -6\text{dB}$ . This threshold is used to recognize the existence of an interfering WirelessMAN-CX source, with which coordination can be performed.

*Acceptable Interference Threshold* – is the boundary between the light interference and acceptable interference ranges. This value is used for recognizing a non-SSU interference source.

In addition to those thresholds, a *Regulatory Threshold* is set according to regulatory requirements for SSU interference sources.

Each of the above threshold levels should be transformed into a suitable *detection threshold*, which is the signal level set to determine if the interference source exists, with a given probability of detection under a given probability of false alarm.

The detection is performed within a given time frame, which is generally different from the symbol time used to determine the operation signal to noise ratio.

If not stated otherwise, the required probability of detection shall be 0.9, and the probability of false alarm shall be  $10^{-4}$ .

### 15.1.1 Components and Relationships

#### **Comment 15**

*Change in p.38 line 19*

**Neighbor Relationship:** it is a relationship between two systems, when the BS in at least one of these two systems creates interference higher than ~~a-certain~~ *the light interference threshold* to at least one SS in another system, or at least one of the SSs in at least one of these two systems creates interference higher than ~~a-certain~~ *the light interference threshold* to the BS in another system.

*Change in p.40 line 19*

**Interference Victim BS/SS:** a BS/SS in an interference victim system is an interference victim BS/SS when the BS/SS is interfered by at least one SS/BS in this system's neighbor system, and the interference is higher than ~~a~~

~~certain~~ [the light interference threshold](#). The interference victim system could be an interference source BS/SS to the SS/BS in its neighbor system at the same time (e.g. BS in system A/B/C and the interference victim SSs in system A/B/C/D in *Figure h 8*), or only an interference victim BS/SS of the interference source SS/BS in its neighbor system (e.g. interference victim BS/SS in System F in *Figure h 9*).

***Change in p.40 line 26***

**Interference Source BS/SS:** a BS/SS in an interference source system is an interference source BS/SS when the BS/SS creates interference to at least one SS/BS in the system's neighbor system, and the interference is higher than ~~a-certain~~ [the light interference threshold](#). The interference source BS/SS could be an interference victim BS/SS of the SS/BS in its neighbor system at the same time (e.g. BS in system A/B/C and the interference source SSs in system A/B/C/D in *Figure h 8*), or only an interference source system of its neighbor system (e.g. Interference source BS/SS in system E in *Figure h 9*).

**15.1.3.1 Procedure flow for BS**

***Comment 223***

***Insert in p.45 line 19***

[The control channel CX\\_CMI\\_D/U\(n\) and the CSI method, to be described below, offer time slots in which none of the members of the existing community transmits any signal.](#) A new BS uses ~~the~~ [this](#) interference free slot to broadcast the message containing the contact request and/or the cognitive radio signal transmitting the IP address

***Comment 227***

***Insert in p. 45 line 43***

If interference detected by the IBS or the OBS system on all the channels, then the IBS should decide whether an optimized channel distribution, [as described in section 15.4.1.1](#), can allocate an exclusive channel for each BS, including the IBS, in the community.

**15.1.5.1 Requirements for the basic and extended coexistence**

***Make the following changes in p. 1.42***

"No system is allowed to create ~~harmful~~ interference to [any SS of](#) a system owning a Master sub-frame, [in a level that would impact its performance](#).

**15.2.2 Scanning before interference identification**

***Comment 15***

***Make the following changes in p.63 l.47***

The IBS should monitor candidate frequencies during the selection of a working frequency. If the interference level is greater than the ~~detection~~ [light interference threshold](#)

## References

- [1] IEEE P802.16h/D1: Air Interface for Fixed Broadband Wireless Access Systems Improved Coexistence Mechanisms for License-Exempt Operation, Draft Standard.
- [2] IEEE C802.6h-06/11; Wu Xuyong: Interference Criteria for WirelessMAN-CX systems. Nov. 2006
- [3] IEEE 80216h-06\_068r2: Letter Ballot #24 Commentary file with resolutions from Session #46.
- [4] IEEE 802.16.2™ -2004 IEEE Recommended Practice for Local and metropolitan area networks Coexistence of Fixed Broadband Wireless Access Systems, 17 March 2004

## Annex 1: Comments Summary

This annex contains the comment from [2] to be resolved via this the action item covered by the contribution.

Comment #	P	L	Section	Comment	Suggested Remedy
15 Xuyong	3	24	3	There is no definition on interference criteria and harmful interference within the draft1, but its necessary.	1) accept proposed text in contribution C802.16h-06_111. 2) make remedy to the relate expression in draft1 accordingly. 3) accept the proposed principle.
188 Xuyong	37	61	15	The most important issue in 16h is interference resolution. But considering the approach to use, we need an interference criteria before any resolution was determined to be effective. also see C80216h-06_047r1: 21 Shawn AI Shawn: Not clear which is the definition of channel availability and what is "log of channel availability - to be considered for improvements	1) Addressing the interference criteria in the document, clarify the threshold of interference - to be resolved - to be used for transmission and receiving information 2) Based on this criteria, we need to check and reform the solutions inside the 16h draft. which means to check the ability of each related mechanism with the threshold. 3) Put this criteria into the scope of criteria for defining the mandatory features.
210 Xuyong	42	6	15.1.2	The condition row: "3: in signaling/messaging range*" need clarification, according to the interference criteria ad-hoc.	add clarification text on the description above the table.
223 Ken	45	19	15.1.3.1	This is unlicensed spectrum we're talking about. There can not be any guaranteed "interference free slot"	Say what you mean. If this is a specific type of CMI or CSI, say so. Be specific, not ambiguous.

2007-01-17

IEEE C802.16h-07/015r1

227	45	41	15.1.3.1	The channel distribution optimization process requires some specific measurements with other BS and SS.	Clarify these measurements (and possibly the associated messages?)
David					
276	52	42	15.1.5.1	The requirement as worded requires that no device ever transmit since each BS owns a master subframe, but transmitting in that master subframe would cause interference during the owner of a different master subframe (albeit not during its master subframe) this requirement restricts the BS to not transmit even in its own master subframe.	Rewrite the requirement to clearly state the real requirement, not an erroneously brief version of the real requirement.
Ken					

## Annex 2: Examples for the various interference ranges and thresholds

This is an example to demonstrate the effect of interference on a receiver operating at a certain level of SINR. Assume a system with the base station (EIRP=40dBm, ignoring the antenna gain, but assuming an horizontal omni-directional pattern, thermal noise density -204dbW/Hz, 10MHz bandwidth in 5.8G band, LOS environment, free space propagation model. We can see the figure below showing the SINR distribution without interference in this system. The figure shows the SINR of a SS within a 100x100 km area around the base station located at  $x = 50\text{km}$ ,  $y = 50\text{km}$  on the coordinate system.

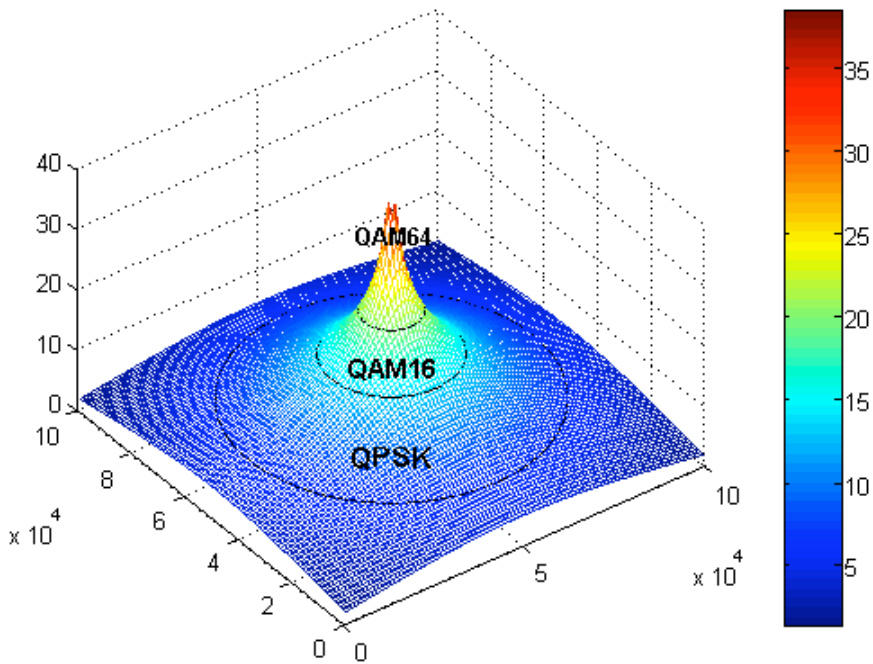

To simplify the case assume that this system is only able to use 3 modulations, QPSK, 16-QAM and 64-QAM. The 3 modulations require minimum SINR of no less than 6.5/14/21 respectively. So the interference endurance distribution expressed by the SINR degradation (the SNR minus the threshold above, which is still smaller than it) with the current modulation is shown below:

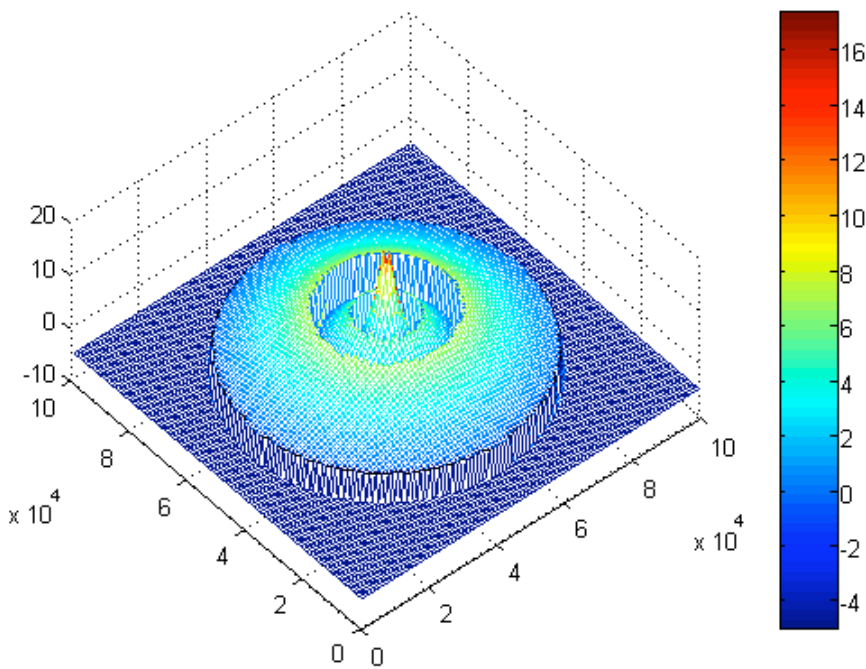

The interference of which the impact is below this endurance will cause no modulation degradation in principle, which means not lower down the throughput of the transmission. So it can be called **Non-harmful**

interference. Notice, the Non-harmful interference is relevant to a specific location, and it doesn't mean that the interference source does not harm the system unless the impact of the interference source to this system is below the endurance everywhere within this system. Otherwise, the non-harmful interference can only be called victim by victim in each location.

In another way, if we provide each modulation a *minimum entry threshold* and a *mandatory exit threshold*, such as what was illustrated in 802.16-2004 figure 81, all the interference lower than the difference of these two thresholds can be harmless:

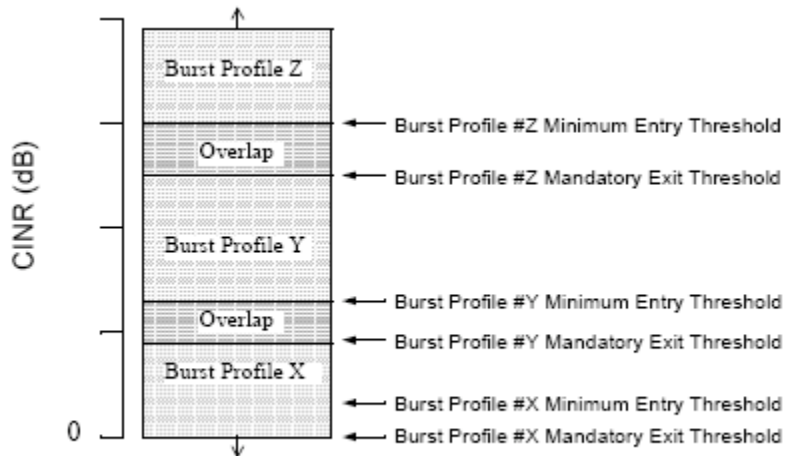
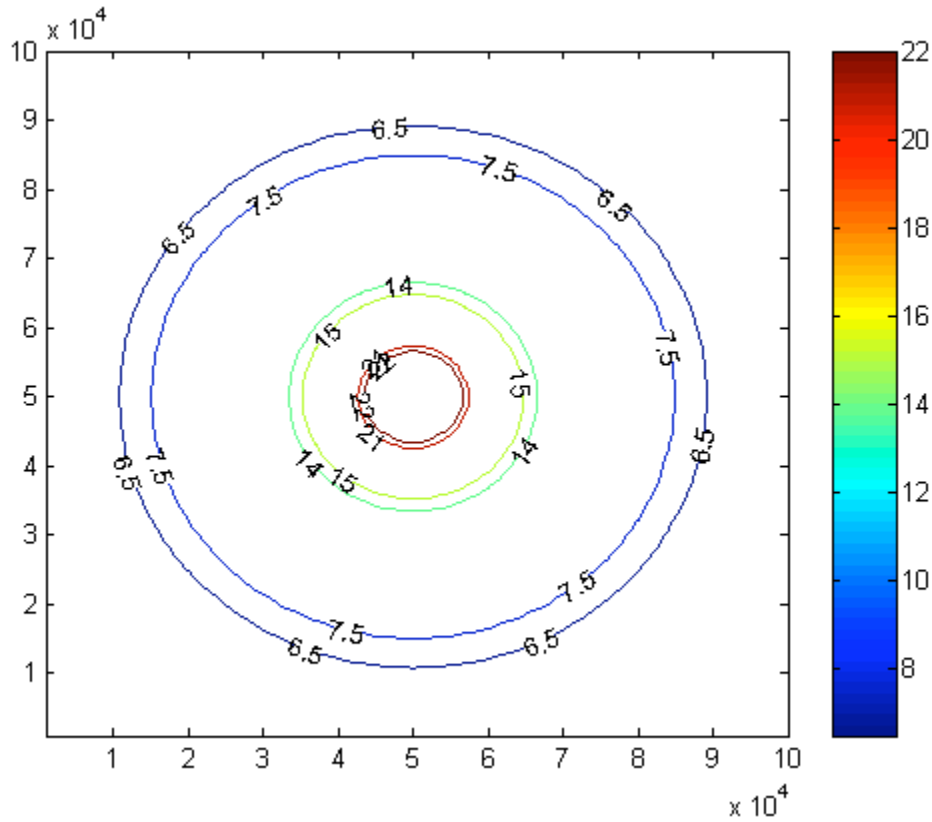

Figure 81—Burst profile threshold usage

Here can be harmless means that all the interference of which the impact is below the threshold will cause no degradation on the modulation. For example, if we set minimum entry threshold of QAM16 to 15 dB and mandatory exit threshold to be 14dB, then the interference whose impact is below 1 dB SINR degradation will cause no trouble of the transceiver.

*With the introduction of OFDMA, variety of coding and antenna techniques, the different levels between system states (and hence the system performance) is becoming almost continuous, this means that any interference, according to that definition, will be harmful. To illustrate it consider in the example above an OFDMA system with 32 subchannels. This system has effectively 96 different levels of performance, so the gaps are much smaller. With SINR=21 dB it can operate with 64QAM 5/6 with a rate of 5bps/Hz. With SINR=20.8dB it can drop to 30 subchannels, thus reducing the rate to 4.7 bps/Hz, still using 64QAM 5/6. So, 0.2 dB is harmful interference already.*

coverage of QAM16 shrinks a little. As shown below:



For example, assume the following parameters for a system:

Modulation & Coding State	AWGN equivalent CINR [dB]
QPSK 1/3	3dB
QPSK _	5dB
QPSK _	6.5dB
16-QAM _	11dB
16-QAM _	14dB
64-QAM _	16dB
64-QAM 2/3	17.5dB
64-QAM _	19dB
64-QAM 5/6	21dB

The following figure shows the various interference levels and thresholds for a system with -100dBm noise level, and received signal strength of -80dBm, which, without interference, can support a rate equivalent to 4.5 bps/Hz (64QAM 3/4), while with CX interference it can sustain rate as low as 1.5 bps/Hz (QPSK 3/4).

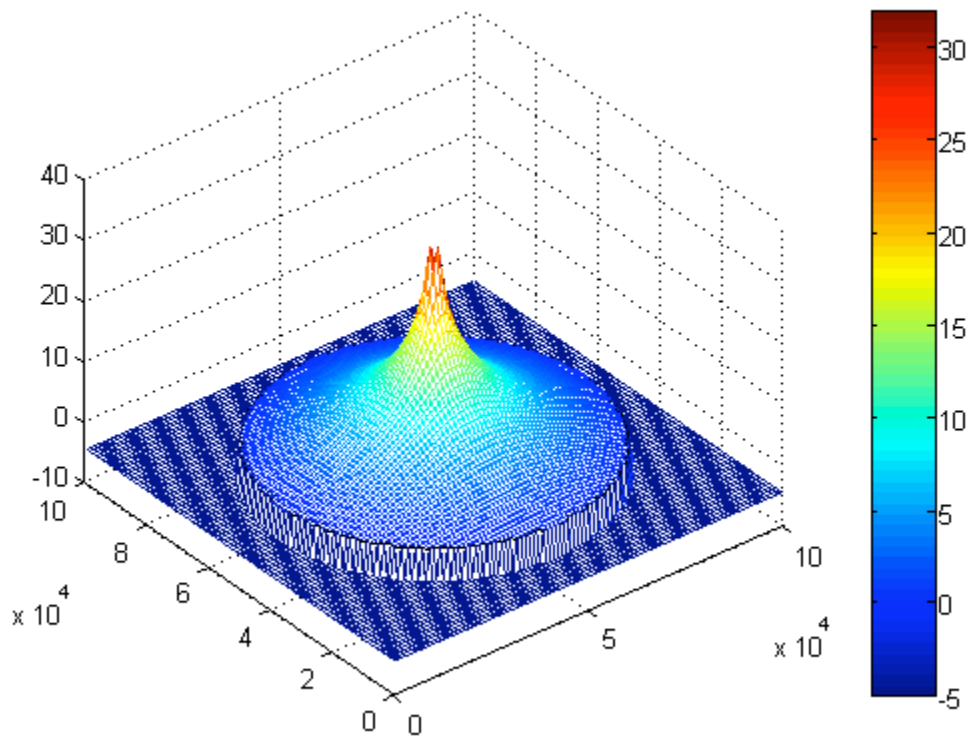
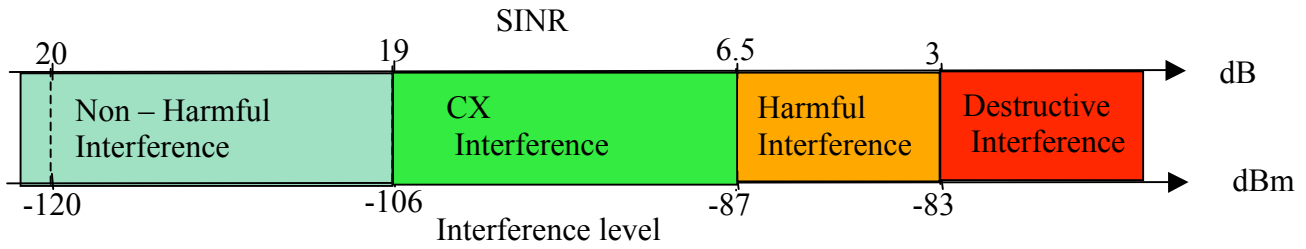

Another example, demonstrates the various interference levels as observed by certain receiver. Assume the following parameters for a system:

<b>Modulation &amp; Coding State</b>	<b>AWGN equivalent CINR [dB]</b>
QPSK 1/3	3dB
QPSK _	5dB



QPSK _	6.5dB
16-QAM _	11dB
16-QAM _	14dB
64-QAM _	16dB
64-QAM 2/3	17.5dB
64-QAM _	19dB
64-QAM 5/6	21dB

The following figure shows the various interference levels for a system with -100dBm noise level, and received signal strength of -78dBm, which, without interference, can support a rate equivalent to 4.5 bps/Hz (64QAM 3/4). while it should accept interference which would reduce the rate it can sustain to be as low as 1.5 bps/Hz (QPSK 3/4).

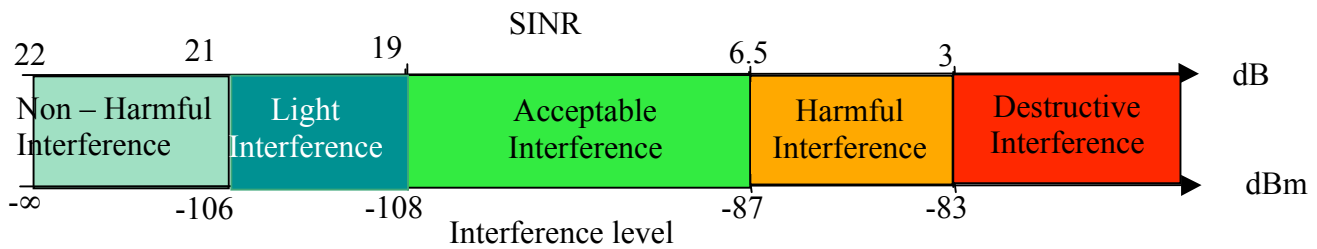

Interference level

