Project	IEEE 802.16 Broadband Wireless Access Working Group < http://ieee802.org/16 >	
Title	Restructuring and Renaming of Management Primitives in section 14.2.9	
Date Submitted	2006-0405-3002	
Source(s)	Jaesun Cha	jscha@etri.re.kr
	ETRI	
	Ronal Mao	rmao@huawei.com
	Huawei Technologies Co., Ltd.	
	Ronny (Yong-Ho) Kim	ronnykim@lge.com
	LG Electronics, Inc.	
Re:	Contribution on comments to IEEE 802.16g/D2	
Abstract	In this contribution, we propose to define some primitives for Neighbor BS Management.	
Purpose	Adoption	
Notice	This document has been prepared to assist IEEE 802.16. It is offered as a basis for discussion and is not binding on the contributing individual(s) or organization(s). The material in this document is subject to change in form and content after further study. The contributor(s) reserve(s) the right to add, amend or withdraw material contained herein.	
Release	The contributor grants a free, irrevocable license to the IEEE to incorporate text contained in this contribution, and any modifications thereof, in the creation of an IEEE Standards publication; to copyright in the IEEE's name any IEEE Standards publication even though it may include portions of this contribution; and at the IEEE's sole discretion to permit others to reproduce in whole or in part the resulting IEEE Standards publication. The contributor also acknowledges and accepts that this contribution may be made public by IEEE 802.16.	

Patent
Policy and
Procedures

The contributor is familiar with the IEEE 802.16 Patent Policy and Procedures (Version 1.0) <<http://ieee802.org/16/ipr/patents/policy.html>>, including the statement “IEEE standards may include the known use of patent(s), including patent applications, if there is technical justification in the opinion of the standards-developing committee and provided the IEEE receives assurance from the patent holder that it will license applicants under reasonable terms and conditions for the purpose of implementing the standard.”

Early disclosure to the Working Group of patent information that might be relevant to the standard is essential to reduce the possibility for delays in the development process and increase the likelihood that the draft publication will be approved for publication. Please notify the Chair <<mailto:r.b.marks@ieee.org>> as early as possible, in written or electronic form, of any patents (granted or under application) that may cover technology that is under consideration by or has been approved by IEEE 802.16. The Chair will disclose this notification via the IEEE 802.16 web site <<http://ieee802.org/16/ipr/patents/notices>>.

Restructuring and Renaming of Management Primitives in section 14.2.9

Jaesun Cha, Ronald Mao, Ronny (Yong-Ho) Kim

ETRI, Huawei Technologies Co., Ltd, LG Electronic, Inc.

1. Motivation

In Section 14.2.9, there are some primitives which control network entry procedure or manage the mobile terminal status. But, the format of the primitives doesn't follow the service primitive template defined in Section 14.1.

In case of Section 14.2.9.9, the section structure also needs to be changed to make it consistent with other sections.

2. Summary of Changes

2.1 Structure of New Sections

14.2.9 Network Entry Management **Primitives**

14.2.9.1 C_NEM-REQ

[In the sub-section, procedures will be described according to the Action Type. Refer the table in 2.3. Change of Primitives.]

14.2.9.2 C_NEM-RSP

[In the sub-section, procedures will be described according to the Action Type. Refer the table in 2.3. Change of Primitives.]

14.2.9.3 C_NEM-NOTIFY

[In the sub-section, procedures will be described according to the Action Type. Refer the table in 2.3. Change of Primitives.]

14.2.10 Mobile Terminal Management

14.2.10.1 M_MTM-REQ

[In the sub-section, procedures will be described according to the Action Type. Refer the table in 2.3. Change of Primitives.]

14.2.10.2 M_MTM-RSP

[In the sub-section, procedures will be described according to the Action Type. Refer the table in 2.3. Change of Primitives.]

14.2.10.3 M_MTM-NOTIFY

[In the sub-section, procedures will be described according to the Action Type. Refer the table in 2.3. Change of Primitives.]

2.2 Change of Section 14.1.1

14.1.1 Universal Naming Schema for SAP Service Primitive

The primitive name defined on the SAP consists of 3 fields - SAP, Function, and Operation:

SAP

- C - Control plane SAP
- M - Management plane SAP

Function

- CM - Configuration Management
- PM - Performance Management
- ACM - Accounting Management
- ALM - Alarm Management
- SM - Security Management
- HO - Hand Off
- PG - Paging
- SFM - Service Flow Management
- SMC - Secondary Management Connection
- RRM - Radio Resource Management
- [NEM – Network Entry Management](#)
- [MTM – Mobile Terminal Management](#)

Operation

- REQ - Request
- RSP - Response to the REQ message
- ACK - Acknowledgement to the reception of REQ or RSP or NOTIFY message
- NOTIFY - Event Notification

2.3 Change of Primitives

Before Change		After Change
M_Ranging		C-NEM-REQ (Action Type = Ranging) C-NEM-RSP (Action Type = Ranging)
M_Registration		M-NEM-NOTIFY (Action Type = Registration)
M_Neighbor		C-NEM-NOTIFY (Action Type = Neighbor)

M_Management	Power On	M-MTM-REQ (Action Type = Power On) M-MTM-RSP (Action Type = Power On)
	Power Down	M-MTM-REQ (Action Type = Power Down) M-MTM-RSP (Action Type = Power Down)
	Reset	M-MTM-REQ (Action Type = Reset) M-MTM-RSP (Action Type = Reset) M-MTM-NOTIFY (Action Type = Reset)
	Deregistration	M-MTM-REQ (Action Type = Deregistration) M-MTM-RSP (Action Type = Deregistration)
	Hold	M-MTM-REQ (Action Type = Hold) M-MTM-NOTIFY (Action Type = Hold)
	Normal	M-MTM-REQ (Action Type = Normal) M-MTM-NOTIFY (Action Type = Normal)

3. Proposed Text Changes

[Modify section 14.1.1as follow]

14.1.1 Universal Naming Schema for SAP Service Primitive

The primitive name defined on the SAP consists of 3 fields - SAP, Function, and Operation:

SAP

- C - Control plane SAP
- M - Management plane SAP

Function

- CM - Configuration Management
- PM - Performance Management
- ACM - Accounting Management
- ALM - Alarm Management
- SM - Security Management
- HO - Hand Off
- PG - Paging
- SFM - Service Flow Management
- SMC - Secondary Management Connection
- RRM - Radio Resource Management
- NEM – Network Entry Management
- MTM – Mobile Terminal Management

Operation

- REQ - Request
- RSP - Response to the REQ message
- ACK - Acknowledgement to the reception of REQ or RSP or NOTIFY message
- NOTIFY - Event Notification

These primitives are symmetrical between the 802.16 Entity and the NCMS. That is, both the 802.16 Entity (SS/MS or BS) and the NCMS can send these primitives depending on the functional behavior defined for M-SAP and C-SAP. ACK shall only be supported across the C-SAP.

[Modify section 14.2.9 as follow]

14.2.9 Network Entry Management Primitives

The Network Entry Management Primitives are a set of primitives for supporting network entry and network re-entry procedures between 802.16 Entity and NCMS.

~~The IEEE 802.16 MAC shall support the following primitives which are delivered through C-SAP (Control Service Access Point) or M_SAP (Management Service Access Point) interfacing with NCMS (Network Control and Management System):~~

- ~~- M_Ranging.request/indication/response/confirmation~~
- ~~- M_Registration.request/indication/response/confirmation~~
- ~~- M_Neighbor.indication~~
- ~~- M_ScanScheduling.request/indication/response/confirmation~~
- ~~- M_Seanning.request/confirmation~~
- ~~- M_MACHandover.request/indication/response/confirmation~~
- ~~- M_HOIND.request/confirmation~~
- ~~- M_Management.request/indication/response/confirmation~~

~~The use of these primitives to provide peer communication is shown in Figure 3. The use of primitive can be divided into two categories. The first category is with interaction with the peer entity, and the second category is primitive exchange within local stack.~~

~~The initial request for service from a higher layer through NCMS is provided by the "Request" primitive. The request triggers to generate appropriate MAC management message and the MAC management message is sent across the air interface to the peer MAC.~~

~~Upon reception of the MAC management message over the air interface, corresponding "Indication" primitive is generated to inform NCMS of the request; When the response for the request is made from the higher layer, the response is delivered through the NCMS by the "Response" primitive. The response triggers to generate appropriate response MAC management message and this message is transmitted over the air interface to the originating side. Upon reception of the response MAC management message over the air interface, corresponding "Confirmation" primitive is generated and delivered to higher layer via NCMS.~~

~~Primitives exchange for the unidirectional MAC management messages, which don't require response messages, such as MOB_HOIND, MOB_TRF-IND, and for the local management of the MAC state machine, is shown in Fig. 3, (2). The initial request for service from a higher layer through NCMS is provided by the "Request" primitive. The request triggers either to generate appropriate unidirectional MAC management message or MAC state change depending on the primitive. "Confirmation" primitive conveying the result of the request is delivered to the higher layer through NCMS.~~

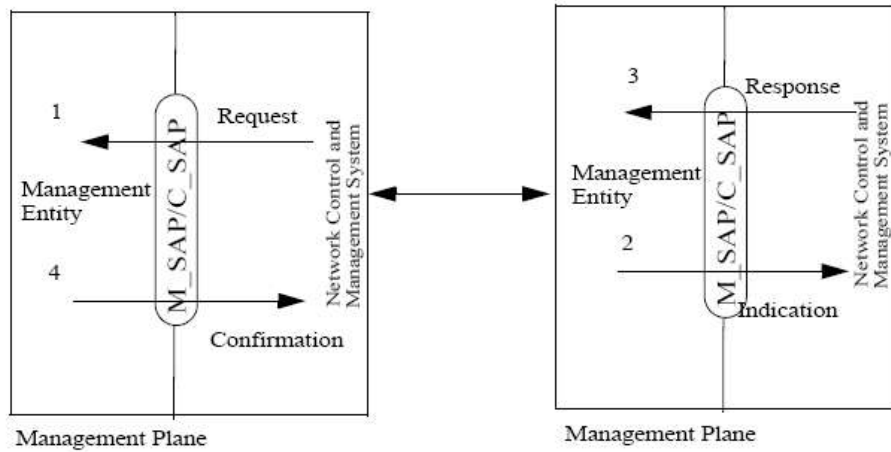

(1) Primitives when Message Exchange is Required with Remote Entity

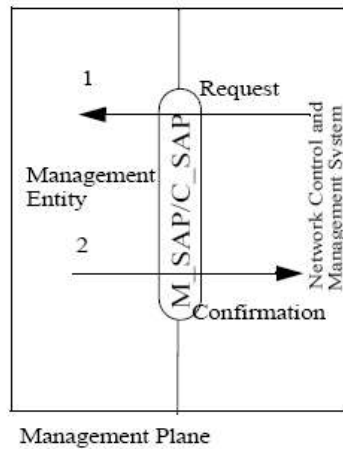

(1) Primitives exchange within Local Entity

Figure 505—The use of primitives to generate MAC management messages

[Modify section 14.2.9.1 as follow]

14.2.9.1 M_Ranging-request/indication/response/confirmationRanging Primitives

Upper layers can control ranging procedure with these primitives. Upper layers shall commence 802.16 link setup procedure by sending M_NEM-REQ(Ranging)M_Ranging-request primitive through NCMS.

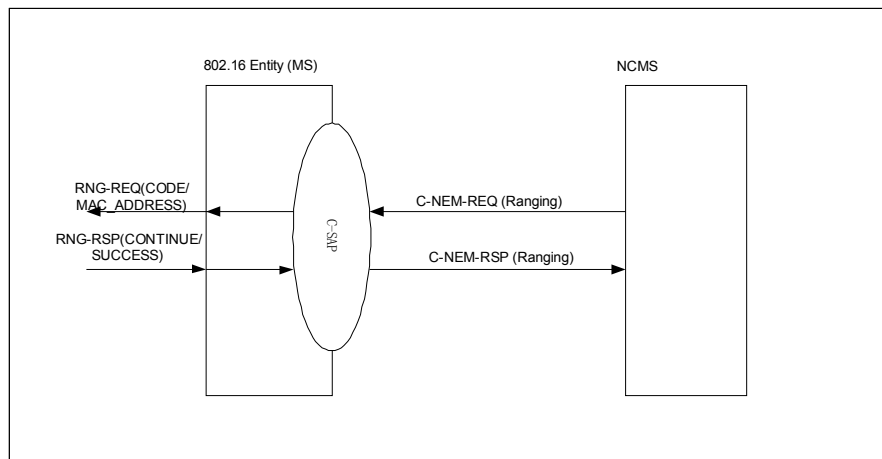
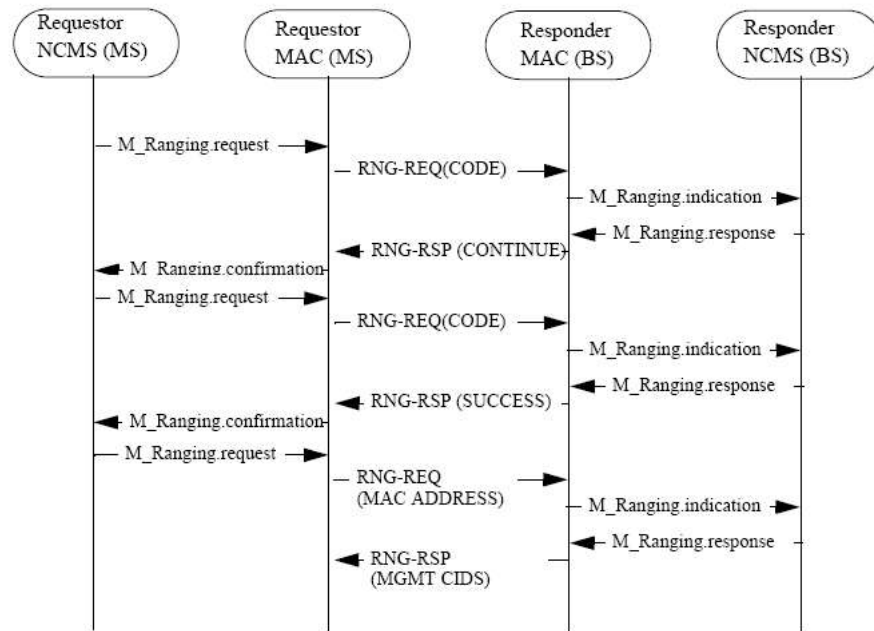

Figure 506 — The use of Ranging Primitives Figure 506a Ranging Primitives (MS Side)

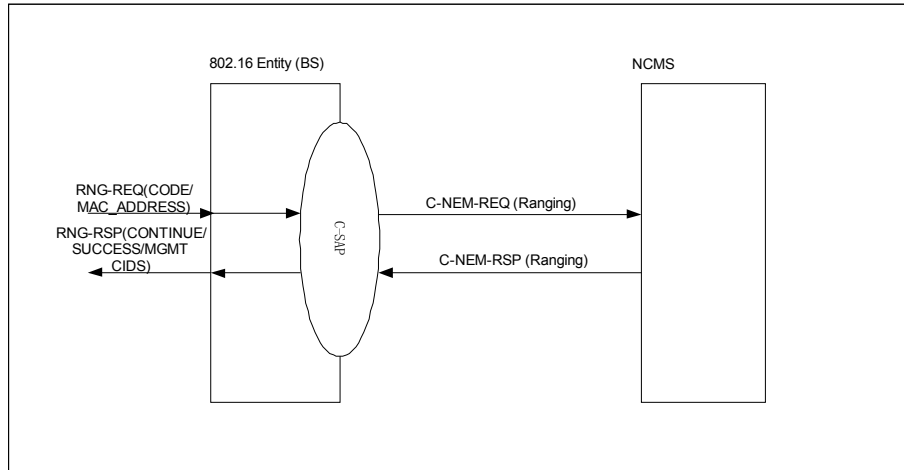

Figure 506b Ranging Primitives (BS Side)

14.2.9.1.1 M_Ranging.request_C-NEM-REQ (NCMS→MS)

14.2.9.1.1.1 Function

This primitive requests ranging. Upper layer management entities shall request ranging by sending this primitive to the MAC layer through NCMS.

14.2.9.1.1.2 Semantics

C-NEM-REQ_M_Ranging.request

```

(
  Operation_type: Set
  Action_type: Ranging
  Object_ID: MS
  Attribute_List:
    Source,
    Destination,
    Ranging Type
)
    
```

Table 455 – RangingM_Ranging.request_Parameters_Request Attributes (MS Side)

Name	Type	Valid Range	Description
Source	EVENT_SOURCE	N/A	The original point from where this primitive is initiated
Destination	EVENT_DESTINATION	N/A	This specifies the destination where this primitive finally arrives

Ranging Type	Enumeration	Initial, Handoff, Location Update, Periodic	This identifies the ranging type
--------------	-------------	---	----------------------------------

14.2.9.1.1.3 When generated

This primitive is generated by the upper layer management entities to initiate ranging procedure for initial network entry, network reentry after handover, periodic ranging, network re-entry from Idle mode, and location update of Idle Mode mobile terminals.

14.2.9.1.1.4 Effect of receipt

MAC layer shall generate RNG-REQ MAC management message including corresponding TLVs depending on the Ranging type and RNG-REQ message shall be sent to the BS over air interface.

14.2.9.1.2 C-NEM-REQ (BS → NCMS) M_Ranging.indication

14.2.9.1.2.1 Function

This primitive notifies the upper layer management entity in BS that the mobile terminal requests ranging with RNG-REQ.

14.2.9.1.2.2 Semantics

C-NEM-REQ M_Ranging.indication

(
Operation_type: Set
Action_type: Ranging
Object_ID: MS
Attribute_List :
 Source,
 Destination,
 MS Address,
 CDMA code,
 MAC Version,
 Required Downlink Burst Profile,
 Serving BS ID,
 Target BS ID,
 HO Indication,
 Location Update Request,
 Paging Controller ID
)

Table 456 – M_Ranging.indication Parameters Ranging Request Attributes (BS Side)

Name	Type	Valid Range	Description
Source	EVENT_SORUCE	N/A	The origination point from where this primitive is initiated

Destination	EVENT_DESTINATION	N/A	This specifies the destination where this primitive finally arrives
MS Address	MAC Address	Any valid individual MAC Address	MAC Address of MS that requests ranging
CDMA Code			CDMA code received for ranging
MAC Version	Enumeration	IEEE Std 802.16-2001, IEEE Std 802.16-2004, IEEE Std 802.16e	MAC version supported by MS
Required Downlink Burst profile			DIUC value of Downlink Burst Profile
Serving BS Id			Serving BS ID during ranging
Target BS Id			Target BS ID during ranging
HO Indication			This parameter indicates the MS is currently attempting to HO or Network Re-entry from Idle Mode to the BS.
Location Update Request			This parameter indicates MS action of Idle Mode Location Process
Paging Controller ID			This is a logical network identifier for the serving BS or other network entity retaining MS service and operational information and/or administering paging activity for the MS while in Idle Mode.

14.2.9.1.2.3 When generated

This primitive is generated by MAC layer when MAC layer receives RNG-REQ message over the air interface.

14.2.9.1.2.4 Effect of receipt

Upon receipt ranging indication, [C-NEM-RSPM_Ranging_response](#) is generated

14.2.9.1.3 [M_Ranging_response_C-NEM-RSP \(NCMS→BS\)](#)

14.2.9.1.3.1 Function

This primitive returns the result of ranging request.

14.2.9.1.3.2 Semantics

C-NEM-RSPM_Ranging_response

```
(
  Operation_type: Set
  Action_type: Ranging
  Object_ID: BS
  Attribute_List:
    Source,
    Destination,
    MS Address,
    Result Code,
    Management CIDs,
    Resource Retain Flag,
    HO Process Optimization,
    Location Update Response,
    Paging information,
    Paging Controller ID,
    Next Periodic Ranging
)
```

Table 457 – **M.Ranging_response Parameters Ranging Response Attributes (BS Side)**

Name	Type	Valid Range	Description
Source	EVENT_SORUCE	N/A	The origination point from where this primitive is initiated
Destination	EVENT_DESTINATION	N/A	This specifies the destination where this primitive finally arrives
MS Address	MAC Address	Any valid individual MAC Address	MAC Address of MS that requests ranging
Result Code	Enumeration		Result of ranging request
Management CID	Enumeration	Basic CID Primary Management CID	Management CID of MS if ranging succeeded
Resource Retain Flag			MT information retained
HO Process Optimization			Network re-entry process optimization after handover
Location Update Response	Enumeration	Success Failure	Location Update result in idle mode

Paging information			Changed paging information if location update succeeded
Paging Controller ID			Idle mode management entity (Paging controller ID)
Next Periodic Ranging			Frame offset of next ranging during sleep mode

14.2.9.1.3.3 When generated

This primitive is generated when decided to notify the ranging result after receiving [M_Ranging.indication ranging request](#).

14.2.9.1.3.4 Effect of receipt

MAC layer sends RNG-RSP message

14.2.9.1.4 [C-NEM-RSP \(MS→NCMS\)M_Ranging.confirmation](#)

14.2.9.1.4.1 Function

This primitive notifies the result of ranging ~~from M_Ranging.response~~ to upper layer entity

14.2.9.1.4.2 Semantics

[C-NEM-RSPM_Ranging.confirmation](#)

(

[Operation_type: Set](#)

[Action_type: Ranging](#)

[Object_ID: NCMS](#)

[Attribute_List:](#)

Source,
Destination,
MS Address,
ResultCode,
ManagementCIDs,
Resource Retain Flag,
HO Process Optimization,
Location Update Response,
Paging Information,
Paging Controller ID,
Next Periodic Ranging

)

Table 458 – M_Ranging_confirmation_Parameters Ranging Response Attributes (MS Side)

Name	Type	Valid Range	Description
Source	EVENT_SORUCE	N/A	The origination point from where this primitive is initiated
Destination	EVENT_DESTINATION	N/A	This specifies the destination where this primitive finally arrives
MS Address	MAC Address	Any valid individual MAC Address	MAC Address of MS that requests ranging
Result Code	Enumeration		Result of ranging request
Management CID	Enumeration	Basic CID Primary Management CID	Management CID of MS if ranging succeeded
Resource Retain Flag			MT information retained
HO Process Optimization			Network re-entry process optimization after handover
Location Update Response	Enumeration	Success Failure	Location Update result in idle mode
Paging information			Changed paging information if location update succeeded
Paging Controller ID			Idle mode management entity (Paging controller ID)
Next Periodic Ranging			Frame offset of next ranging during sleep mode

14.2.9.1.4.3 When generated

This primitive is generated when MAC layer receives RNG-RSP message.

14.2.9.1.4.4 Effect of receipt

The upper layer entity receives the result of ranging

[Modify section 14.2.9.2 as follow]

14.2.9.2 M_Registration.request/indication/response/confirmationRegistration Primitives

Upper layers can control registration procedure with these primitives. Upper layers are notified of link setup by M_Registration_confirmation: C-NEM-RSP/Registration.

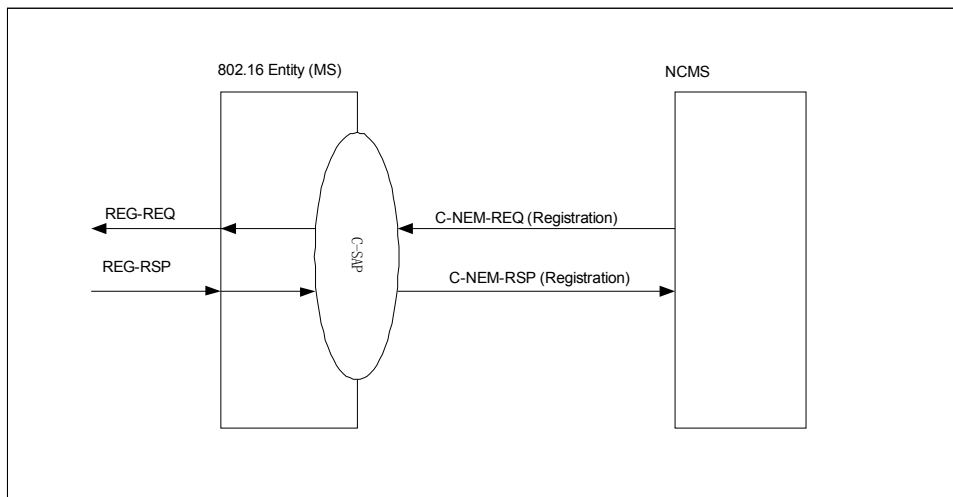
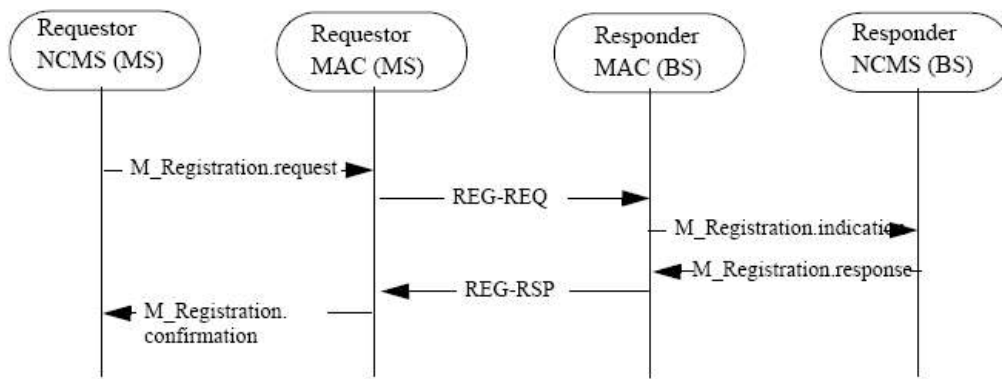

Figure 507 – The use of Registration Primitives [Figure 507a Registration Primitives \(MS Side\)](#)

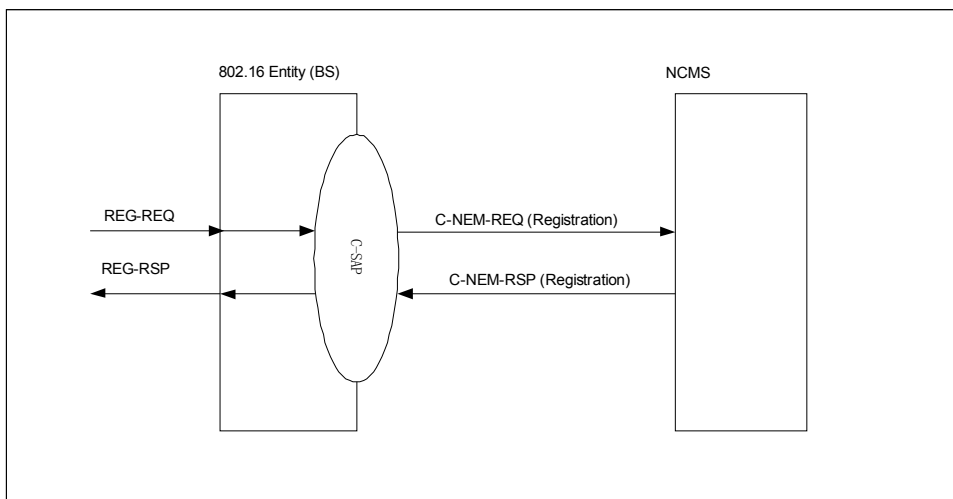

Figure 507b Registration Primitives (BS Side)

14.2.9.2.1 [M_Registration.request C-NEM-REQ \(NCMS→MS\)](#)

14.2.9.2.1.1 Function

This primitive is initiated by the upper layer entity to request registration.

14.2.9.2.1.2 Semantics

[C-NEM-REQM_Registration.request](#)

(
Operation_type: Set
Action_type: Registration
Object_ID: MS
Attribute_List:
 Source,
 Destination,
 IP management mode,
 IP Version,
 Method of Allocating IP Address,
 Previous IP Address
)

Table 459 – M_Registration.request Parameters Registration Request Attributes (MS Side)

Name	Type	Valid Range	Description
Source	EVENT_SOURCE	N/A	The original point from where this primitive is initiated
Destination	EVENT_DESTINATION	N/A	This specifies the destination where this primitive finally arrives
IP management mode	Enumeration	Unmanaged Mode Managed Mode	This identifies the ranging type
IP Version	Enumeration	Version 4 Version 6	IP Version
Method of Allocation IP Address	Enumeration	DHCP Mobile IPv4 DHCP IPv6 Mobile IPv6 IPv6 Stateless address auto configuration	IP Address Configuration method
Previous IP Address	IP Address		Previously assigned IP Address of MS on the secondary management connection.

14.2.9.2.1.3 When generated

This primitive is generated when upper layer entity requests registration

14.2.9.2.1.4 Effect of receipt

REG-REQ message including necessary TLV parameter is sent

14.2.9.2.2 M_Registration.indication_C-NEM-REQ (BS→NCMS)

14.2.9.2.2.1 Function

This primitive notifies that upper layer entity requests registration

14.2.9.2.2.2 Semantics

M_Registration.indication

(
Operation_type: Set

Action_type: Registration
Object_ID: NCMS
Attribute_List:
 Source,
 Destination,
 IP management mode,
 IP Version,
 Method of Allocating IP Address,
 Previous IP Address
)

14.2.9.2.2.3 When generated

~~This primitive is generated when MAC layer receives REG-REQ message.~~

14.2.9.2.2.4 Effect of receipt

~~M_Registraion.response is generated.~~

14.2.9.2.3 M_Registration.response

14.2.9.2.3.1 Function

~~This primitive returns the result of registration request.~~

14.2.9.2.3.2 Semantics

```

M_Registration.response
(
  Source;
  Destination;
  IP management mode;
  IP Version;
  Method of Allocating IP Address;
  Skip IP Address Acquisition
)
  
```

14.2.9.2.2.3 When generated

This primitive is generated when MAC layer receives REG-REQ message.

14.2.9.2.2.4 Effect of receipt

C-NEM-RSP is generated.

14.2.9.2.3 C-NEM-RSP (NCMS → BS)

14.2.9.2.3.1 Function

This primitive returns the result of registration request.

14.2.9.2.3.2 Semantics

```

C-NEM-RSP
(
  Operation_type: Set
  Action_type: Registration
)
  
```

[Object ID: BS](#)
[Attribute List:](#)
[Source](#),
[Destination](#),
[IP management mode](#),
[IP Version](#),
[Method of Allocating IP Address](#),
[Skip IP Address Acquisition](#)

)

14.2.9.2.3.3 When generated

This primitive is generated to notify the result of registration after M_Registration.indication is received

14.2.9.2.3.4 Effect of receipt

MAC layer sends REG-RSP message

14.2.9.2.4 M_Registration.confirmation

14.2.9.2.4.1 Function

This primitive notifies the registration result from M_Registration.response to upper layer entity

Table 460 – M_Registration.indication Parameters Registration Request Attributes (BS Side)

Name	Type	Valid Range	Description
Source	EVENT_SOURCE	N/A	The original point from where this primitive is initiated
Destination	EVENT_DESTINATION	N/A	This specifies the destination where this primitive finally arrives
IP management mode	Enumeration	Unmanaged Mode Managed Mode	This identifies the ranging type
IP Version	Enumeration	Version 4 Version 6	IP Version
Method of Allocation IP Address	Enumeration	DHCP Mobile IPv4 DHCP IPv6 Mobile IPv6 IPv6 Stateless address auto configuration	IP Address Configuration method
Previous IP Address	IP Address		Previously assigned IP Address of MS on the secondary management connection.

Table 461 – M_Registration.response Parameters Registration Response Attributes (BS Side)

Name	Type	Valid Range	Description
Source	EVENT_SOURCE	N/A	The original point from where this primitive is initiated

Destination	EVENT_DESTINATION	N/A	This specifies the destination where this primitive finally arrives
IP management mode	Enumeration	Unmanaged Mode Managed Mode	This identifies the ranging type
IP Version	Enumeration	Version 4 Version 6	IP Version
Method of Allocation of IP Address	Enumeration	DHCP Mobile IPv4 DHCP IPv6 Mobile IPv6 IPv6 Stateless address auto configuration	IP Address Configuration method
Skip IP Address Acquisition	Enumeration	No IP address change RE-acquire IP address	This indicates to an MS whether it should reacquire its IP address on the secondary management connection and related context or reuse its prior context

14.2.9.2.3.3 When generated

This primitive is generated to notify the result of registration after C-NEM-REQ/Registration is received.

14.2.9.2.3.4 Effect of receipt

MAC layer sends REG-RSP message.

14.2.9.2.4 C-NEM-RSP (MS → NCMS)

14.2.9.2.4.1 Function

This primitive notifies the registration result from C-NEM-RSP to upper layer entity.

14.2.9.2.4.2 Semantics

C-NEM-RSPM_Registration.confirmation

```
(
  Operation_type: Set
  Action_type: Registration
  Object_ID: NCMS
  Attribute_List:
    Source,
    Destination,
    IP management mode,
    IP Version,
    Method of Allocating IP Address,
    Skip Address Acquisition
)
```

14.2.9.2.4.3 When generated

This primitive is generated when REG-RSP is received

Table 462 – ~~M-Registration.confirmation Parameters~~ **Registration Response Attributes (MS Side)**

Name	Type	Valid Range	Description
Source	EVENT_SOURCE	N/A	The original point from where this primitive is initiated
Destination	EVENT_DESTINATION	N/A	This specifies the destination where this primitive finally arrives
IP management mode	Enumeration	Unmanaged Mode Managed Mode	This identifies the ranging type
IP Version	Enumeration	Version 4 Version 6	IP Version
Method of Allocation IP Address	Enumeration	DHCP Mobile IPv4 DHCP IPv6 Mobile IPv6 IPv6 Stateless address auto configuration	IP Address Configuration method
Skip IP Address Acquisition	Enumeration	No IP address change RE-acquire IP address	This indicates to an MS whether it should reacquire its IP address on the secondary management connection and related context or reuse its prior context

14.2.9.2.4.3 When generated

This primitive is generated when REG-RSP is received.

14.2.9.2.4.4 Effect of receipt

Registration result is notified to the upper layer entity

[Modify section 14.2.9.3 as follow]

14.2.9.3 Neighbor Advertisement Primitives ~~M-Neighbor.indication~~

When 802.16 MAC receives neighbor advertisement (MOB_NBR-ADV), this primitive is used to deliver the information to upper layers.

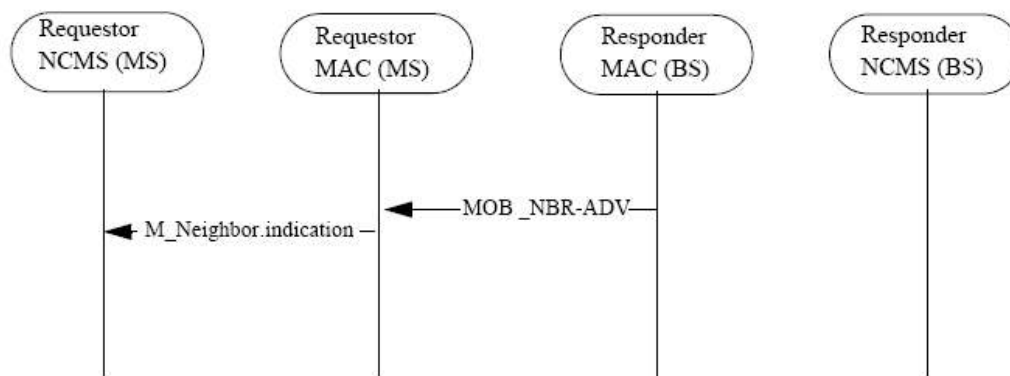

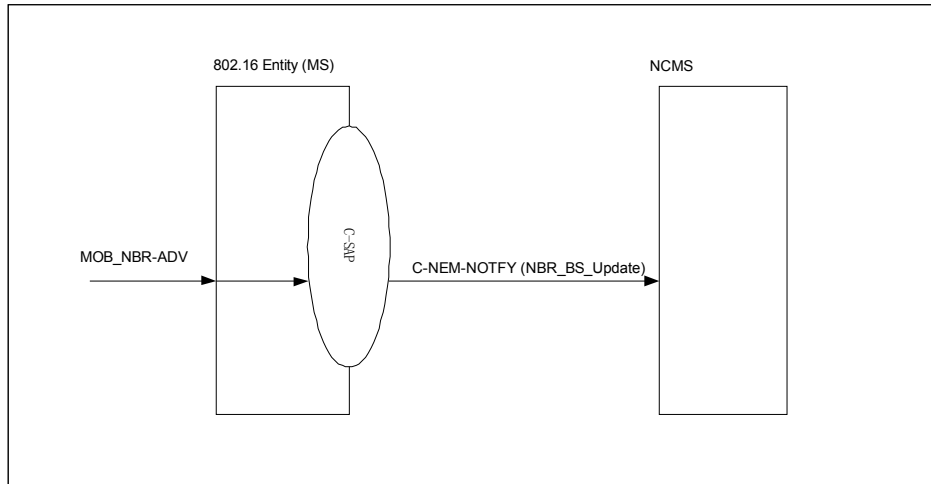

Figure 508 – The use of Neighbor Advertisement Indication Neighbor Advertisement Primitives

14.2.9.3.1 M_Neighbor.indicationC-NEM-NOTFY

14.2.9.3.1.1 Function

This primitive is generated by MAC layer to notify the upper layer entity of reception of neighbor advertisement (MOB_NBR-ADV) from BS.

14.2.9.3.1.2 Semantics

M_Neighbor.indicationC-NEM-NOTFY

(
Message ID,
Event Type : NBR_BS_Update,
Object ID : NCMS,
Attribute_list:
 Source,
 Destination,
 Operator ID,
 N_Neighbors,
 Neighbor BS-ID,
 HO Process Optimization,
 Current BS's MIH Capability INFO
 MIH INFO Bitmap
)

14.2.9.3.1.3 When generated

This primitive is generated for the MAC layer to notify the upper layer entity of MOB_NBR-ADV contents received from the BS.

14.2.9.3.1.4 Effect of receipt

Upper layer entity acquires information of BSes.

Table 463 – M_Neighbor.indication Parameters Neighbor Advertisement Attributes

Name	Type	Valid Range	Description
Source	EVENT_SOURCE	N/A	The original point from where this primitive is initiated

Destination	EVENT_DESTINATION	N/A	This specifies the destination where this primitive finally arrives
Operator ID			Unique ID assigned to the operator
N_Neighbors			The count of the unique combination of Neighbor BSID, Preamble Index and DCD.
Neighbor BS-ID			Base station ID

<p>HO Process Optimization</p>	<p>Enumeration</p>	<p>Bit #0: Omit SBCREQ/RSP management messages during re-entry processing Bit #1: Omit PKM Authentication phase except TEK phase during current re-entry processing Bit #2: Omit PKM TEK creation phase during re-entry processing Bit #3: Omit REGREQ/RSP management messages during current re-entry processing Bit #4: Omit Network Address Acquisition management messages during current re-entry processing Bit #5: Omit Time of Day Acquisition management messages during current re-entry processing Bit #6: Omit TFTP management messages during current re-entry processing Bit #7: Full service and operational state transfer or sharing between serving BS and target BS (ARQ, timers, counters, MAC state machines, etc...)</p>	<p>Network re-entry process optimization after handover</p>
<p>Current BS's MIH Capability MIH INFO</p>	<p>Enumeration</p>	<p>MIH Not Supported MIH Supported</p>	<p>This indicates whether current BS delivering neighbor advertisement supports MIH or not.</p>

MIH INFO bitmap	Enumeration	Available WLAN AP, Available WLAN AP MIH Enabled, Available WLAN AP MIH Capability unknown, Available 3GPP BS, Available 3GPP BS MIH Enabled, Available 3GPP BS MIH Capability unknown, Available 3GPP2 BS, Available 3GPP2 BS MIH Enabled, Available 3GPP2 BS MIH Capability unknown.	
-----------------	-------------	--	--

[Delete Section 14.2.9.9 as follow]

[Create a New Section 14.2.10 as follow]

14.2.10 Mobile Terminal Management

The Mobile Terminal Management Primitives are a set of primitives to manage the status of mobile terminal. A management entity in NCMS can change the status of mobile terminal into power on/down/de-register, etc. Those primitives are also used to notify NCMS of information or events which are related with the status of mobile terminal.

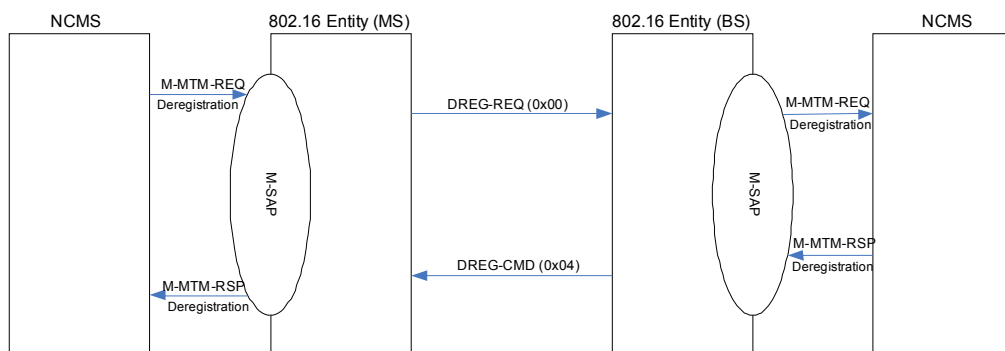

Figure xxx – Mobile Terminal Management primitives flow between 802.16 Entity and NCMS, De-Registration

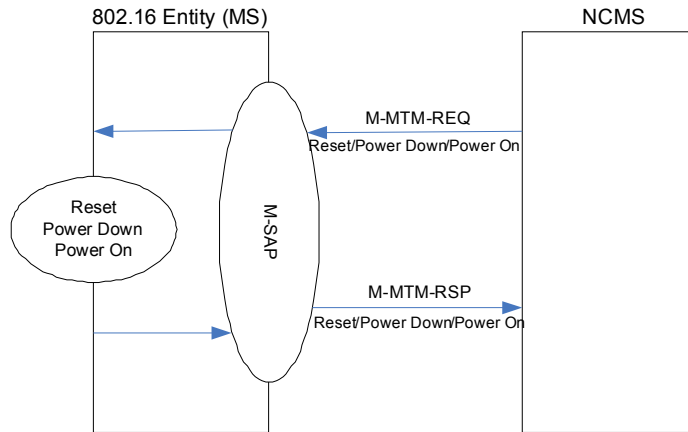

Figure xxx – Mobile Terminal Management primitives flow between 802.16 Entity and NCMS, Reset / Power On / Power Down at MS side

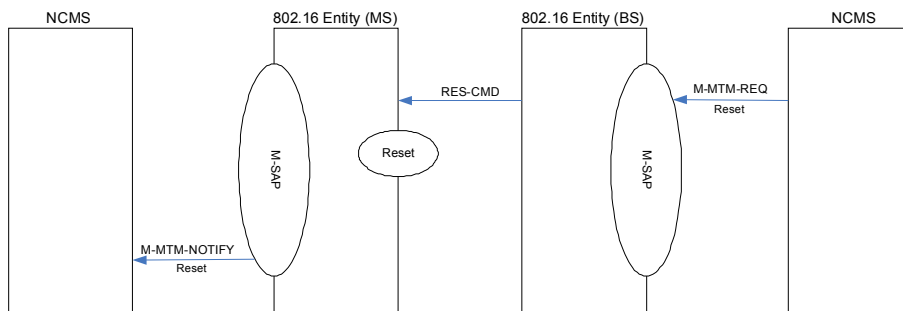

Figure xxx – Mobile Terminal Management primitives flow between 802.16 Entity and NCMS, Reset at BS side

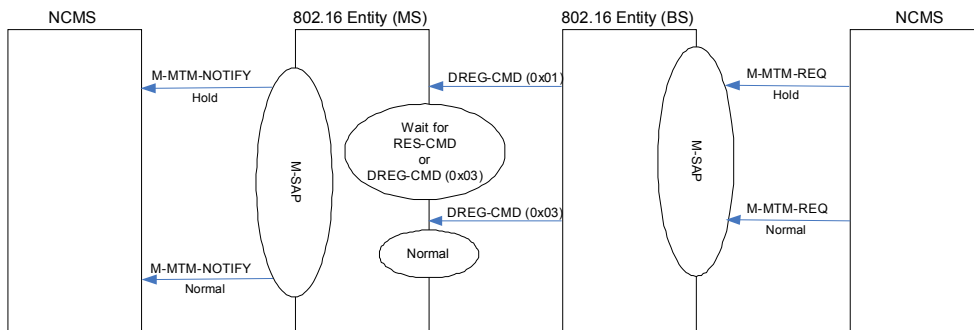

Figure xxx – Mobile Terminal Management primitives flow between 802.16 Entity and NCMS, Hold and Normal

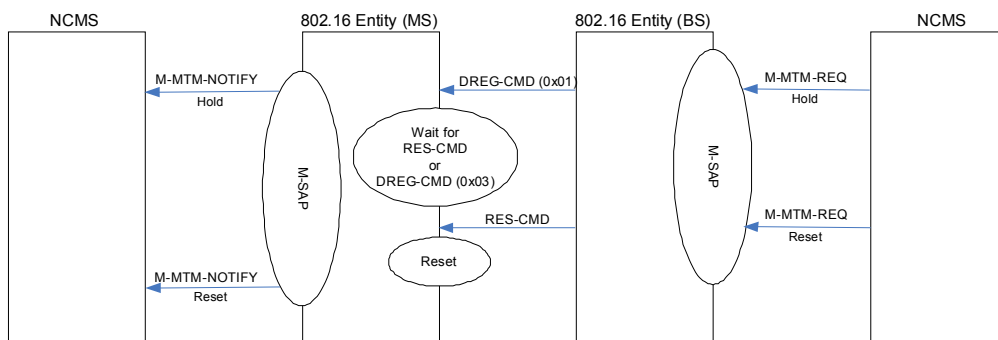

Figure xxx – Mobile Terminal Management primitives flow between 802.16 Entity and NCMS, Hold and Reset

14.2.10.1 M-MTM-REQ

This primitive is used by NCMS or 802.16 entity to request status change of the MS. The Action Type included in this primitive defines the type of status change to be performed. The possible Action Type for this primitive are listed in Table below:

<u>Action Type</u>	<u>Description</u>
<u>Power On</u>	<u>Power on procedure between MS and NCMS</u>
<u>Power Down</u>	<u>Power down procedure between MS and NCMS</u>
<u>Reset</u>	<u>Reset procedure</u>
<u>Deregistration</u>	<u>Deregistration procedure.</u>
<u>Hold</u>	<u>Hold procedure between 802.16 Entity and NCMS</u>
<u>Normal</u>	<u>Returning procedure to normal mode between 802.16 Entity and NCMS</u>

14.2.10.1.1 M-MTM-REQ (Action Type == Power On)

14.2.10.1.1.1 Function

This primitive is used by NCMS to change the status of MS to Power On. This primitive is only used by NCMS at MS side.

14.2.10.1.1.2 Semantics of the service primitive

The following parameters are included in this primitive.

```

M-MTM-REQ
(
  Message_id
  Operation_Type(Action)
  Action_Type (Power On)
  Object_id (MS_ID)
  Attribute_list
)

```

14.2.10.1.1.3 When generated

This primitive is generated when a higher layer entity in NCMS wants to request the 802.16 MS entity to power on.

14.2.10.1.1.4 Effect of receipt

The 802.16 entity at MS performs power on procedure and responds to it with M-MTM-RSP primitive.

14.2.10.1.2 M-MTM-REQ (Action Type == Power Down)

14.2.10.1.2.1 Function

This primitive is used by NCMS to change the status of MS to Power Down. This primitive is only used by NCMS at MS side.

14.2.10.1.2.2 Semantics of the service primitive

The following parameters are included in this primitive.

```

M-MTM-REQ
(

```

```

    Message_id,
    Operation_Type(Action),
    Action_Type (Power Down),
    Object_id (MS_ID),
    Attribute_list:
  )

```

14.2.10.1.2.3 When generated

This primitive is generated when a higher layer entity in NCMS wants to request the 802.16 MS entity to power down.

14.2.10.1.2.4 Effect of receipt

The 802.16 entity in MS performs power down procedure

14.2.10.1.3 M-MTM-REQ (Action Type == Reset)

14.2.10.1.3.1 Function

This primitive is used by NCMS at MS or BS to reset the mobile terminal.

14.2.10.1.3.2 Semantics of the service primitive

The following parameters are included in this primitive.

```

M-MTM-REQ
(
  Message_id,
  Operation_Type(Action),
  Action_Type (Reset),
  Object_id (MS_ID or BS ID),
  Attribute_list:
    MS ID,
    Reset Code
)

```

```

MS ID
  MS Identifier
Reset Code
  Reason for reset

```

14.2.10.1.3.3 When generated

This primitive is generated when a higher layer entity in NCMS wants to reset the mobile terminal.

14.2.10.1.3.4 Effect of receipt

If the 802.16 MS entity receives this primitive, it shall re-initialize its MAC and responds to the request with M-MTM-RSP primitive. If the 802.16 BS entity receives this primitive, it shall send RES-CMD message to the mobile terminal.

14.2.10.1.4 M-MTM-REQ (Action Type == Deregistration)

14.2.10.1.4.1 Function

This primitive is used by NCMS at MS side to trigger the deregistration procedure. It is also used by the 802.16 entity at BS to notify NCMS of deregistration request when it receives DREG-REQ message from the MS.

14.2.10.1.4.2 Semantics of the service primitive

The following parameters are included in this primitive.

M-MTM-REQ

```
(
  Message_id
  Operation_Type(Action)
  Action_Type (Deregistration)
  Object_id (MS_ID or NCMS)
  Attribute_list:
    Action Code
)
```

Action Code

Indication of de-registration type.

14.2.10.1.4.3 When generated

This primitive is generated when a higher layer entity in NCMS at MS wants to de-register the service from 802.16 networks. It is also generated by the 802.16 BS entity to notify NCMS of deregistration request when it receives DREG-REQ message from the MS.

14.2.10.1.4.4 Effect of receipt

The 802.16 entity at MS shall send DREG-REQ message to the serving BS for de-registration. Action code included in DREG-REQ message corresponds to the Action Code in M-MTM-REQ primitive. If NCMS at BS receives this primitive, it shall responds to it with M-MTM-RSP primitive after deregistration process.

14.2.10.1.5 M-MTM-REQ (Action Type == Hold)

14.2.10.1.5.1 Function

This primitive is used by NCMS to change the status of the mobile terminal into the hold status. This primitive is only used by NCMS at BS side.

14.2.10.1.5.2 Semantics of the service primitive

The following parameters are included in this primitive.

M-MTM-REQ

```
(
  Message_id
  Operation_Type(Action)
  Action_Type (Hold)
  Object_id (BS_ID)
  Attribute_list:
    MS ID
)
```

MS ID

MS identifier14.2.10.1.5.3 When generated

This primitive is generated when a higher layer entity in NCMS wants to change the status of the mobile terminal into the hold status.

14.2.10.1.5.4 Effect of receipt

If the 802.16 BS entity receives this primitive, it shall send DREG-REQ message with action code = 0x01 to the MS.

14.2.10.1.6 M-MTM-REQ (Action Type == Normal)14.2.10.1.6.1 Function

This primitive is used by NCMS to change the status of the mobile terminal of which current status is hold status into the normal status. This primitive is only used by NCMS at BS side.

14.2.10.1.6.2 Semantics of the service primitive

The following parameters are included in this primitive.

```

M-MTM-REQ
  (
    Message_id
    Operation_Type(Action)
    Action_Type (Normal)
    Object_id (BS_ID)
    Attribute_list:
      MS ID
  )

```

```

MS ID
  MS identifier

```

14.2.10.1.6.3 When generated

This primitive is generated when a higher layer entity in NCMS wants to change the status of mobile terminal of which current status is hold into the normal status.

14.2.10.1.6.4 Effect of receipt

If the 802.16 BS entity receives this primitive, it shall send DREG-REQ message with action code = 0x03 to the MS.

14.2.10.2 M-MTM-RSP

This primitive is used by a 802.16 entity or NCMS to responds a mobile terminal management request. The Action type included in this primitive defines the type of management procedure to be performed. The possible Action Type for this primitive is listed in Table below:

<u>Action Type</u>	<u>Description</u>
<u>Power On</u>	<u>Power on procedure</u>
<u>Power Down</u>	<u>Normal power off procedure</u>
<u>Reset</u>	<u>Reset procedure</u>

DeregistrationNormal deregistration14.2.10.2.1 M-MTM- RSP (Action Type == Power On)14.2.10.2.1.1 Function

This primitive is generated by the 802.16 entity to respond to M-MTM-REQ (Power On). This primitive is only used by NCMS at MS side.

14.2.10.2.1.2 Semantics of the service primitive

The following parameters are included in this primitive.

```

M-MTM-REQ
  (
    Message_id,
    Operation_Type(Action),
    Action_Type (Power On),
    Object_id (NCMS),
    Attribute_list:
      Result Code
  )

```

14.2.10.2.1.3 When generated

This primitive is generated when the 802.16 MS entity receives M-MTM-REQ (Power On) primitive from NCMS.

14.2.10.2.1.4 Effect of receipt

NCMS completes power-on procedure.

14.2.10.2.2 M-MTM- RSP (Action Type == Power Down)14.2.10.2.2.1 Function

This primitive is generated by the 802.16 entity to respond to M-MTM-REQ (Power Down). This primitive is only used by NCMS at MS side.

14.2.10.2.2.2 Semantics of the service primitive

The following parameters are included in this primitive.

```

M-MTM-REQ
  (
    Message_id,
    Operation_Type(Action),
    Action_Type (Power Down),
    Object_id (NCMS),
    Attribute_list:
      Result Code
  )

```

14.2.10.2.2.3 When generated

This primitive is generated when the 802.16 MS entity receives M-MTM-REQ (Power Down) primitive from NCMS.

14.2.10.2.2.4 Effect of receipt

NCMS completes power-down procedure.

14.2.10.2.3 M-MTM- RSP (Action Type == Reset)

14.2.10.2.3.1 Function

This primitive is generated by the 802.16 entity to respond to M-MTM-REQ (Reset). This primitive is only used by NCMS at MS side.

14.2.10.2.3.2 Semantics of the service primitive

The following parameters are included in this primitive.

```

M-MTM-REQ
(
  Message_id,
  Operation_Type(Action),
  Action_Type (Reset),
  Object_id (NCMS),
  Attribute_list:
    Result Code
)

```

14.2.10.2.3.3 When generated

This primitive is generated when the 802.16 MS entity receives M-MTM-REQ (Reset) primitive from NCMS.

14.2.10.2.3.4 Effect of receipt

NCMS completes reset procedure.

14.2.10.2.4 M-MTM- RSP (Action Type == Deregistration)

14.2.10.2.4.1 Function

This primitive is generated by the 802.16 MS entity or NCMS to respond to M-MTM-REQ (Deregistration).

14.2.10.2.4.2 Semantics of the service primitive

The following parameters are included in this primitive.

```

M-MTM-REQ
(
  Message_id,
  Operation_Type(Action),
  Action_Type (Reset),
  Object_id (BS_ID or NCMS),
  Attribute_list:
    MS ID
)

```

```

        Action Code
        Result Code
    )

```

14.2.10.2.4.3 When generated

This primitive is generated when the 802.16 entity at MS or NCMS at BS receives M-MTM-REQ (Deregistration).

14.2.10.2.4.4 Effect of receipt

If NCMS receives this primitive, it completes deregistration procedure. If the 802.16 entity at BS receives this primitive, it shall send DREG-CMD message to the MS.

14.2.10.3 M-MTM-NOTIFY

This primitive is used by the 802.16 entity at MS to notify NCMS of some events. The possible event types for this primitive are listed in Table below:

<u>Action Type</u>	<u>Description</u>
<u>Reset</u>	<u>Reset procedure initiated by the BS</u>
<u>Hold</u>	<u>Request from the BS to change the current status to the hold status</u>
<u>Normal</u>	<u>Request from the BS to return back to the normal status</u>

14.2.10.3.1 M-MTM-NOTIFY (Action Type == Reset)

14.2.10.3.1.1 Function

This primitive is generated by the 802.16 entity to notify NCMS of a reset event. This primitive is only used by the 802.16 entity at MS side.

14.2.10.3.1.2 Semantics of the service primitive

The following parameters are included in this primitive.

```

M-MTM-NOTIFY
(
    Message_id,
    Operation_Type(Action),
    Action_Type (Reset),
    Object_id (NCMS),
    Attribute_list:
        MS ID
)

```

14.2.10.3.1.3 When generated

This primitive is generated when the 802.16 entity at MS receives RES-CMD message from the BS. The 802.16 entity issues this primitive after internal reset procedure.

14.2.10.3.1.4 Effect of receipt

NCMS performs internal reset procedure.

14.2.10.3.2 M-MTM-NOTIFY (Action Type == Hold)

14.2.10.3.2.1 Function

This primitive is generated by the 802.16 entity to notify NCMS of a hold event. This primitive is only used by the 802.16 entity at MS side.

14.2.10.3.2.2 Semantics of the service primitive

The following parameters are included in this primitive.

```

M-MTM-NOTIFY
  (
    Message_id,
    Operation_Type(Action),
    Action_Type (Hold),
    Object_id (NCMS),
    Attribute_list:
      MS ID
  )

```

14.2.10.3.2.3 When generated

This primitive is generated when the 802.16 entity at MS receives DREG-CMD message with action code = 0x01 from the BS.

14.2.10.3.2.4 Effect of receipt

NCMS waits for the next M-MTM-NOTIFY primitive with Action Type = Normal or Reset.

14.2.10.3.3. M-MTM-NOTIFY (Action Type == Normal)14.2.10.3.3.1 Function

This primitive is generated by the 802.16 entity to notify NCMS of a normal event. This primitive is only used by the 802.16 entity at MS side.

14.2.10.3.3.2 Semantics of the service primitive

The following parameters are included in this primitive.

```

M-MTM-NOTIFY
  (
    Message_id,
    Operation_Type(Action),
    Action_Type (Normal),
    Object_id (NCMS),
    Attribute_list:
      MS ID
  )

```

14.2.10.3.3.3 When generated

This primitive is generated when the 802.16 entity at MS receives DREG-CMD message with action code = 0x03 from the BS.

14.2.10.3.3.4 Effect of receipt

| [NCMS returns back to the normal status.](#)