

Project	IEEE 802.16 Broadband Wireless Access Working Group < http://ieee802.org/16 >
Title	Addition of SS Basic Capability Negotiation in Network Entry Management
Date Submitted	2007-01-18
Source(s)	Jee Hyeon Na, ETRI, E-mail: jhna@etri.re.kr Jaesun Cha, ETRI, E-mail : jscha@etri.re.kr JungMo Moon, PhD, ETRI, E-mail: jmmoon@etri.re.kr Mi-Young Yoon, ETRI, E-mail: myyun@etri.re.kr Sang Ho Lee, PhD, ETRI, E-mail: leesh@etri.re.kr Yun Won Chung, PhD, Soongsil University, E-mail: ywchung@ssu.ac.kr Ronald Mao, Huawei,
Re:	Call for Comment on P802.16g D6 Document
Abstract	This contribution proposes service primitives for network entry.
Purpose	The document should be considered during the resolution of comments on the D6 document.
Notice	This document has been prepared to assist IEEE 802.16. It is offered as a basis for discussion and is not binding on the contributing individual(s) or organization(s). The material in this document is subject to change in form and content after further study. The contributor(s) reserve(s) the right to add, amend or withdraw material contained herein.
Release	The contributor grants a free, irrevocable license to the IEEE to incorporate material contained in this contribution, and any modifications thereof, in the creation of an IEEE Standards publication; to copyright in the IEEE's name any IEEE Standards publication even though it may include portions of this contribution; and at the IEEE's sole discretion to permit others to reproduce in whole or in part the resulting IEEE Standards publication. The contributor also acknowledges and accepts that this contribution may be made public by IEEE 802.16.
Patent Policy and Procedures	The contributor is familiar with the IEEE 802.16 Patent Policy and Procedures < http://ieee802.org/16/ipr/patents/policy.html >, including the statement "IEEE standards may include the known use of patent(s), including patent applications, provided the IEEE receives assurance from the patent holder or applicant with respect to patents essential for compliance with both mandatory and optional portions of the standard." Early disclosure to the Working Group of patent information that might be relevant to the standard is essential to reduce the possibility for delays in the development process and increase the likelihood that the draft publication will be approved for publication. Please notify the Chair < mailto:chair@wirelessman.org > as early as possible, in written or electronic form, if patented technology (or technology under patent application) might be incorporated into a draft standard being developed within the IEEE 802.16 Working Group. The Chair will disclose this notification via the IEEE 802.16 web site < http://ieee802.org/16/ipr/patents/notices >.

Addition of SS Basic Capability Negotiation in Network Entry Management

Jee Hyeon Na, Jaesun Cha*, JungMo Moon*, Mi-Young Yoon*, Sang Ho Lee*,
Yun Won Chung** and Ronald Mao****

* ETRI, 161, Gajeong-dong, Yuseong-gu, Daejeon, 305-700, Korea

** Soongsil University, 511 Sangdo-dong, Dongjak-gu, Seoul, 156-743, Korea

***Huawei,

1. Introduction

In Section 14.2.7, network entry management is described, where network entry procedure consists of ranging, registration, and network attachments. The current network entry management, however, does not contain SS basic capability negotiation during initial network entry. Since NCMS (MS) does not know when it should generate C-NEM-REQ(registration) primitive without indication from 802.16 Entity(MS) because it does not know whether SS basic capability negotiation procedure in MAC layer is completed or not, SS basic capability negotiation should be included for network entry management procedures. Thus, in this contribution, we propose to add SS basic capability negotiation primitives and related procedures in Section 14.2.7.

2. Proposed Text Changes

[Inserts the following figure between figure 498 and figure 499 in Section 14.2.7.1]

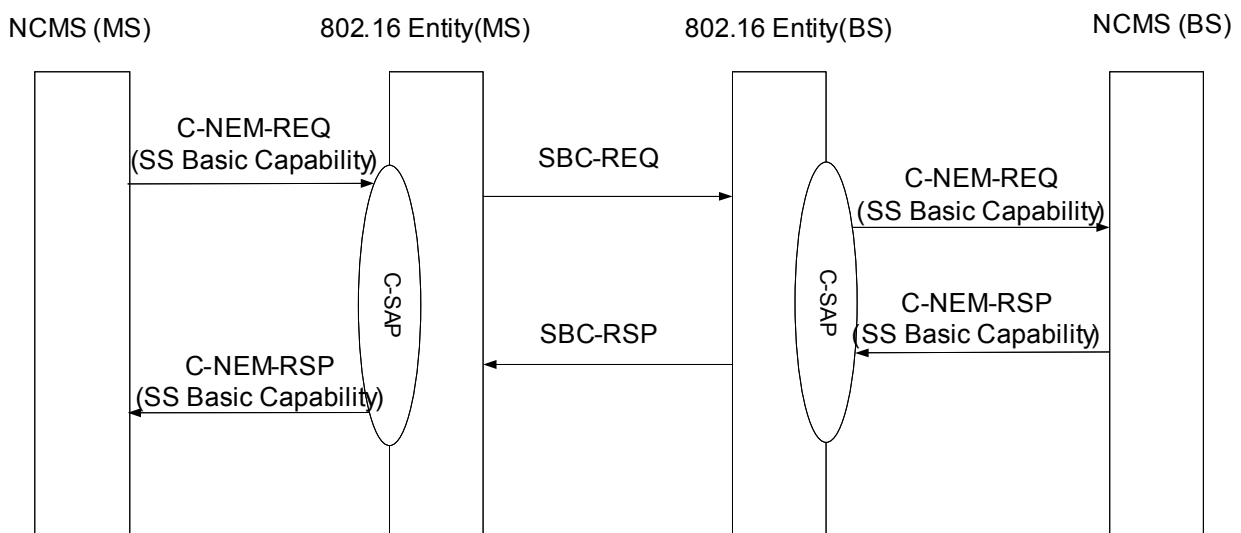

Figure xxx – SS Basic Capability Negotiation Primitives (MS and BS)

[Modify table in section 14.2.7.1 as follows]

Action type	Description
Ranging	Ranging procedures between 802.16 Entity and NCMS
SS Basic Capability	SS Basic Capability negotiation procedures between 802.16 Entity and NCMS
Registration	Registration Procedures between 802.16 Entity and NCMS

[Insert as follows before 14.2.7.1.2.]

14.2.7.1.2 C-NEM-REQ (Action = SS Basic Capability)

Function:

This primitive is initiated by the upper layer entity to request SBC (SS Basic Capability).

Semantics:

```

C-NEM-REQ
(
    Operation_type: Set
    Action_type: SS Basic Capability
    Destination: MS or NCMS
    Attribute_List:
        MS MAC Address,
        Authorization Policy
        Service Information Query (SIQ)
)

```

MS MAC Address
48-bit MAC Address which identify MS.

Authorization Policy
Enumerated type which indicates authorization policy used by MS and BS. The value can be assigned to No Authorization, Only EAP-based authorization, Authenticated EAP authorization after EAP authorization, Only RSA-based authorization, authenticated EAP-based authorization after RSA authorization, or EAP-based authorization after RSA-based authorization.

Service Information Query
1Byte Service Information Query to request the Service Network Provider Identifiers supported by the Operator Network that includes the current BS.

When generated:

This primitive is generated by NCMS at MS after receiving ranging response message. This primitive is also generated by BS when the BS receives SBC-REQ message over the air interface.

Effect of receipt:

The 802.16 entity (MS) generates SBC-REQ MAC message when it receives C-NEM-REQ (SS Basic Capability). The NCMS at BS processes the information from this primitive and shall generate C-NEM-RSP(SS Basic Capability).

[Insert as follows before 14.2.7.2.2.]

14.2.7.2.2 C-NEM-RSP (Action = SS Basic Capability)**Function:**

This primitive is returned by the result of SS Basic Capability request.

Semantics:

```
C-NEM-RSP
(
  Operation_type: Set
  Action_type: SS Basic Capability
  Destination: BS or NCMS
  Attribute_List:
    MS MAC Address,
    Authorization Policy
    NSP List
    NSP Change Count
)
```

MS MAC Address
48-bit MAC Address which identify MS.

Authorization Policy
Enumerated type which indicates authorization policy used by MS and BS. The value can be assigned to No Authorization, Only EAP-based authorization, Authenticated EAP authorization after EAP authorization, Only RSA-based authorization, authenticated EAP-based authorization after RSA authorization, EAP-based authorization after RSA-based authorization.

NSP List
One or more 24-bit Network Service Provider Identifiers.

NSP Change Count
1 Byte NSP Change Count which indicates a change of the NSP list. It will be increased by one (modulo 256) whenever the NSP list changes.

When generated:

This primitive is generated to respond to C-NEM-REQ(SS Basic Capability) from BS. It is also

used by the MS when the MS receives SBC-RSP MAC message.

Effect of receipt:

The BS generates SBC-RSP MAC message and sends it to MS. The NCMS at MS receives SS basic capability results.