

Project	IEEE 802.16 Broadband Wireless Access Working Group < http://ieee802.org/16 >
Title	IEEE 802.16g Amendments for IEEE 802.21 MIH Information Service Support for Network Selection
Date Submitted	2007-01-12
Source(s)	Ronny Kim, Jin Lee LG Electronics, Inc. mailto: ronnykim, jins978@lge.com
Re:	IEEE 802.16 Session #47 in London
Abstract	This contribution proposes the updates of IEEE 802.16g D5 document in order to support IEEE 802.21 Media Independent Information Services.
Purpose	Update 802.16g draft to support Media Independent Handover
Notice	This document has been prepared to assist IEEE 802.16. It is offered as a basis for discussion and is not binding on the contributing individual(s) or organization(s). The material in this document is subject to change in form and content after further study. The contributor(s) reserve(s) the right to add, amend or withdraw material contained herein.
Release	The contributor grants a free, irrevocable license to the IEEE to incorporate material contained in this contribution, and any modifications thereof, in the creation of an IEEE Standards publication; to copyright in the IEEE's name any IEEE Standards publication even though it may include portions of this contribution; and at the IEEE's sole discretion to permit others to reproduce in whole or in part the resulting IEEE Standards publication. The contributor also acknowledges and accepts that this contribution may be made public by IEEE 802.16.
Patent Policy and Procedures	The contributor is familiar with the IEEE 802.16 Patent Policy and Procedures < http://ieee802.org/16/ipr/patents/policy.html >, including the statement "IEEE standards may include the known use of patent(s), including patent applications, provided the IEEE receives assurance from the patent holder or applicant with respect to patents essential for compliance with both mandatory and optional portions of the standard." Early disclosure to the Working Group of patent information that might be relevant to the standard is essential to reduce the possibility for delays in the development process and increase the likelihood that the draft publication will be approved for publication. Please notify the Chair < mailto:chair@wirelessman.org > as early as possible, in written or electronic form, if patented technology (or technology under patent application) might be incorporated into a draft standard being developed within the IEEE 802.16 Working Group. The Chair will disclose this notification via the IEEE 802.16 web site < http://ieee802.org/16/ipr/patents/notices >.

802.16g Amendments for 802.21 Services

Ronny (Yong-Ho) Kim, Jin Lee – LG Electronics

1. Introduction

In order for MS to enter 802.16 network for the first time, MS shall obtain UCD and DCD then will commence network entry procedure by initiating initial ranging procedure. Current 802.16 specifications specify operator ID and 802.16g draft specifies delivery mechanism of Network Service Provider IDs. Network selection depending on IDs has some limitations. That is, mapping information of IDs shall be stored on the MS and freshness of stored information shall be ensured. Sometimes more information is required to make right decision for network selection. In addition to 802.16 ID based network discovery and selection, 802.21 information service can provide necessary information for network discovery and selection when MS does not have pre-stored information or needs more information on the network.

1.1 Interworking procedures: MIH Information Services

This clause describes the actions and the procedures to enable network selection for IEEE 802.16 MS as well as the seamless interworking of a multi-access capable MSs with other non-802.16 access technologies or when other non-802.16 specific network protocols are involved. It specifies the transport mechanisms to advertise services for network selection. IEEE 802.21 MIH capability is included in the DCD in order for MSs to use network selection using IEEE 802.21 Information service. IEEE 802.21 Information service is used for Queries and Query Responses. The network selection information delivery mechanism using IEEE 802.21 Information service is supported using two options:

- i) Broadcast mechanism
- ii) Unicast mechanism

1.1.1 Broadcast Mechanism

The MS obtains the IEEE 802.21 capability from DCD. In the IEEE 802.21 capability indications of DCD, three key services supported by the current BS are indicated. When information service during network entry is allowed, after basic capability negotiation, MS can send Queries embedded in PKM-REQ. BS can identify MSs with MIH capability during basic capability negotiation procedure. Upon receipt of MIH query frame in PKM-REQ MAC management message BS generates a PKM-RSP with Cycle TLV. NCMS of the BS proxies or forwards the query request to the backbone network to retrieve the query results. This NCMS procedure with backbone network is out of scope of IEEE 802.16g and shall not be specified in the draft. The response message from the backbone network (information server) will be queued in the BS for broadcast delivery at later time. BS's scheduling information of broadcast delivery is informed to the MS through the Cycle TLV of PKM-RSP transmitted to the MS. MS shall monitor the frame indicated by Cycle TLV. If the SII-ADV message with query response is not delivered, MS shall monitor next cycle for the message. MS can wait until predetermined counter is exhausted. While waiting for the frame indicated by Cycle TLV, MS does not need to remain active. BS shall only transmit the PKM-RSP with Query Response only in the frame indicated by Cycle TLV. PKM-RSP message carrying Query Response MIH frame TLV includes Query ID which was assigned during the initial request message exchange. The following figure shows the message sequence.

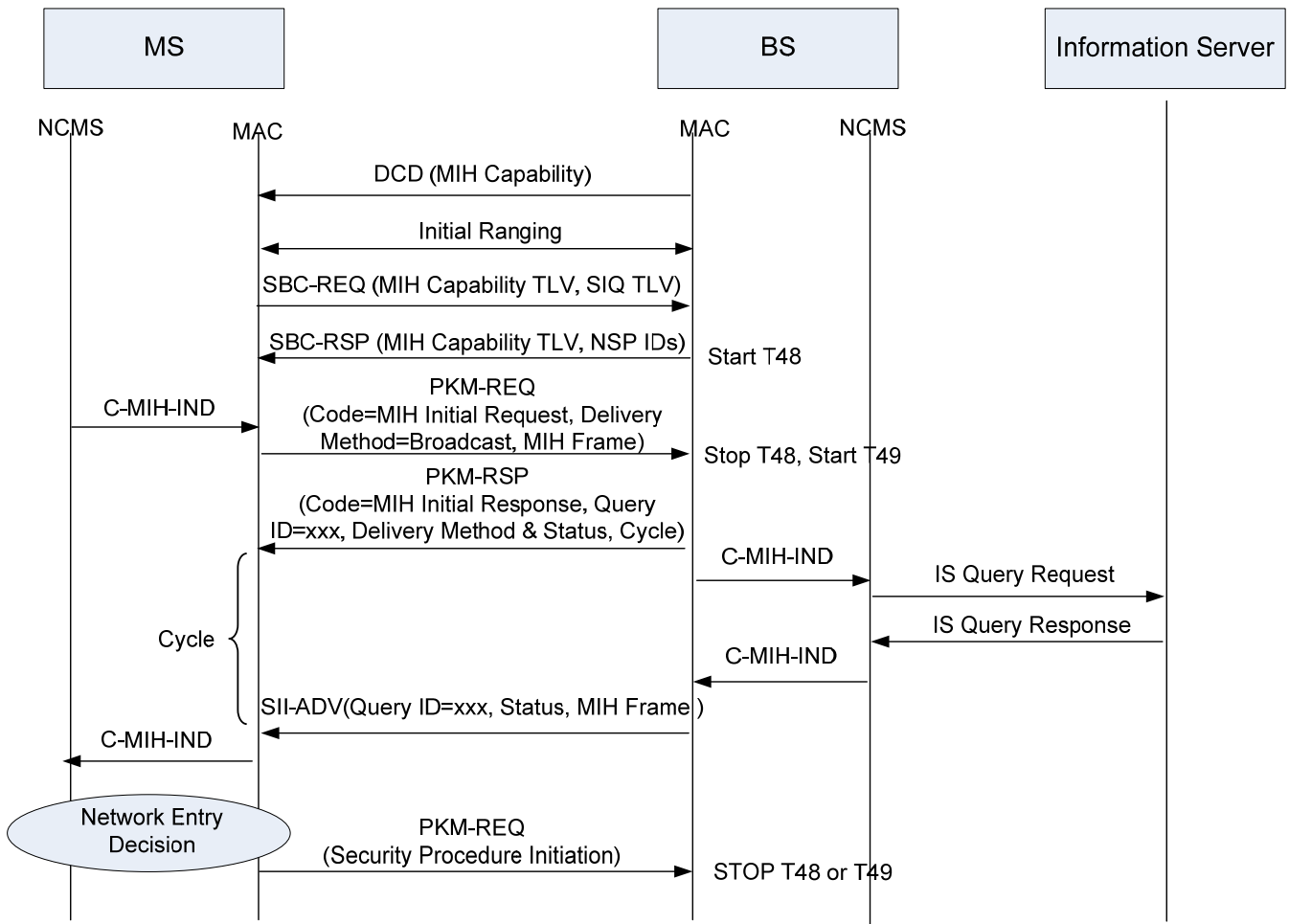

Figure 1. Network Selection information delivery using broadcast delivery method.

1.1.2 Unicast Mechanism

The MS obtains the IEEE 802.21 capability from DCD. In the IEEE 802.21 capability indications of DCD, three key services supported by the current BS are indicated. When information service during network entry is allowed, after basic capability negotiation procedure, MS can send Queries embedded in PKM-REQ. BS can identify MSs with MIH capability during basic capability negotiation. Upon receipt of MIH frame in PKM-REQ MAC management message BS generates a PKM-RSP with Query ID TLV and Cycle TLV. NCMS of the BS proxies or forwards the request to the backbone network to retrieve the query results. This NCMS procedure with backbone network is out of scope of IEEE 802.16g and shall not be specified in the draft. The response message from the backbone network (information server) will be queued in the BS for unicast delivery at later time. BS's scheduling information of query response delivery is informed to the MS in the Cycle TLV of PKM-RSP transmitted to the MS. MS shall check whether MIH_Polling_IE is included in the UL-MAP of the frame indicated by Cycle TLV. When MIH_Polling_IE exists in the UL-MAP, MS shall send PKM-REQ with same Query ID which was assigned during the initial message exchange. Upon receipt of the PKM-REQ from the MS which is the query originator, BS can make sure whether MS still stays to receive Query response message and BS transmits PKM-RSP containing Query Response MIH frame to the MS. BS only includes MIH_Polling_IE in the UL-MAP when the Query Response is received from the backbone network. MS can wait the delivery of MIH_Polling_IE until predetermined counter is exhausted. While waiting for the frame indicated by Cycle TLV, MS does not need to remain active. The following figure shows the message sequence.

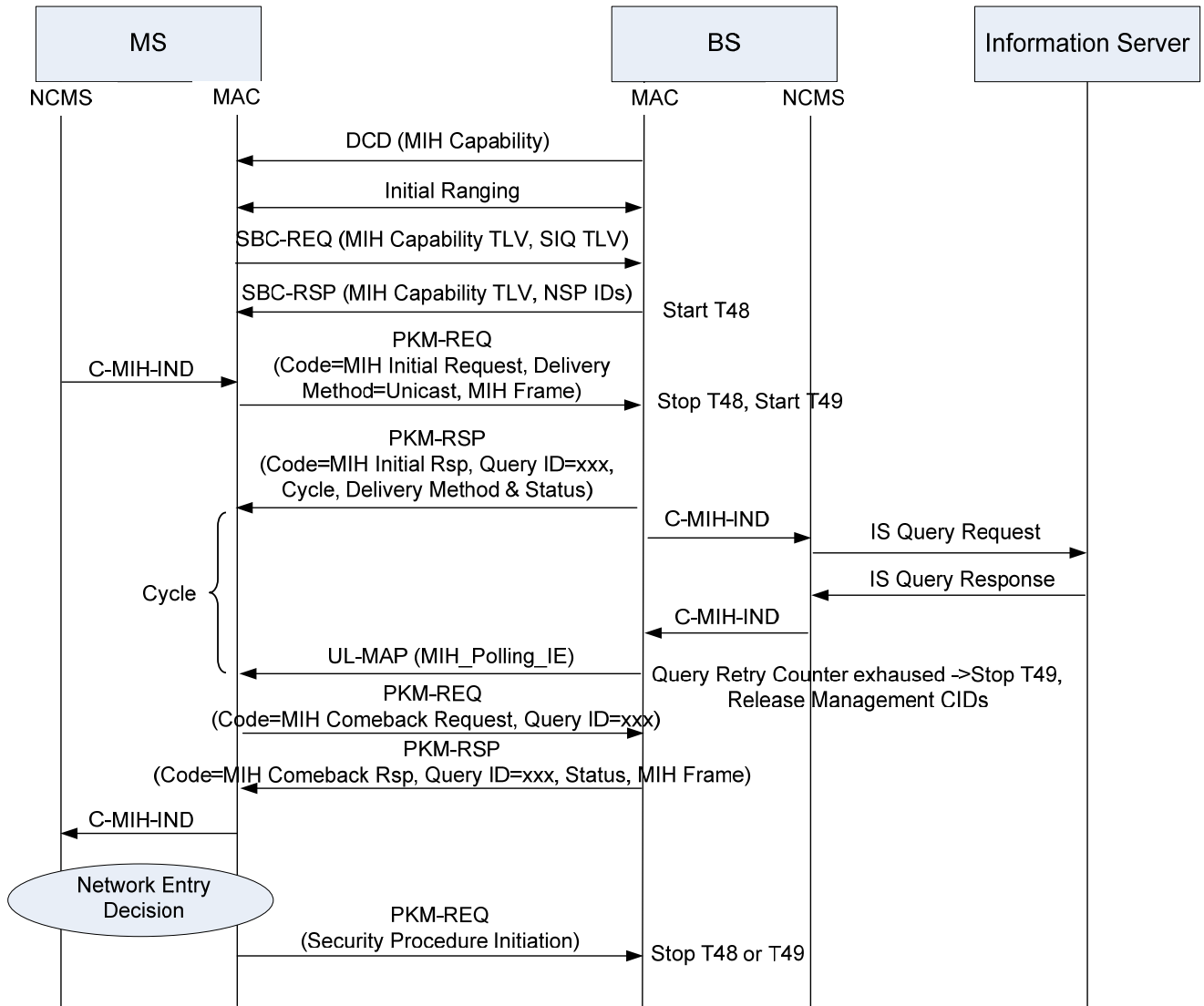

Figure 2. Network Selection information delivery using unicast delivery method.

2. Proposed Text Change

Remedy 1:

MIH Capability advertisement through DCD shall carry more capabilities using reserved bits.

[In 11.4.1 DCD channel encoding, page 21, line 26, Modify]:

Name	Type	Length	Value	PHY Scope
MIH Capability Support	55	1	<p><u>Indicates the capability of IEEE 802.21 Media Independent Handover Services. Setting each bit to 1 indicates corresponding service is supported.</u></p> <p><u>Setting bit # 0 to 1 indicates MIH services indicated through bit #1~3 are supported by the current BS.</u></p> <p><u>Setting more than one of bit #1~3 without setting bit #0 indicates existence of an MIH service entity within the Layer 2 broadcast domain of the current BS. In this case transport MIH MAC management message (MOB_MIH-MSG) is not supported by the BS.</u></p> <p><u>When bit #4 is set to be 1, MS is allowed to transmit MIH information service request MIH function frame TLV (11.20.1) in PKM-REQ.</u></p> <p><u>When bit #5 is set to be 1, MS is allowed to transmit MIH function frame TLV (11.20.1) for ES/CS Capability discovery in PKM-REQ</u></p> <p><u>Bit #0=MIH (Media Independent Handover) Capability not supported</u></p> <p><u>1=MIH Capability supported</u></p> <p><u>Bit #1 = Event Service support</u></p> <p><u>Bit #2 = Command Service support</u></p> <p><u>Bit #3 = Information Service support</u></p> <p><u>Bit #4 = Information Service support during network entry</u></p> <p><u>Bit #5 = ES/CS capability discovery support during network entry</u></p> <p><u>Bit #6~7: reserved</u></p>	All

Remedy 2:

In order for an MS to negotiate MIH capability, MIH capability negotiation during registration is added in the current draft. This capability negotiation shall be changed to be performed during basic capability negotiation. More detailed capability negotiation is required.

[In 11.7.26 MIH Capability Supported TLV, page 22, line 38, modify]:

11.7.26.8.9 MIH Capability Supported TLV

The "MIH Capability Supported" TLV indicates if MIH is supported. MS and BS that support the MIH handover function shall identify themselves by inclusion of the MIH capability supported. MS and BS that do not support the 802.21 MIH handover function shall not support the MOB_MIH-MSG management message. However, BS may indicate the existence of the MIH service entity within the layer 2 broadcast domain of the current BS by setting bit # 0 to be 0 and corresponding services bits of MIH service entity to be 1. In this case, BS doesn't support MOB MIH-MSG MAC management message and MN shall access the MIH service entity using layer 2 data frames. BS may provide network discovery query mechanism during network entry using MIH frames. BS shall indicate capability of the network discovery query using bit #4 and 5.

[In 11.7.26 MIH Capability Supported TLV, page 22, line 38 ,modify]:

Type	Length	Value	Scope
46	1	<p><u>Indicates the capability of IEEE 802.21 Media Independent Handover Services. Setting each bit to 1 indicates corresponding service is supported.</u></p> <p><u>Setting bit # 0 to 1 indicates MIH services which further indicated through bit #1~3 are supported. In REG-RSP transmitted from BS, more than one of bit #1~3 without setting bit #0 may be set which indicates existence of an MIH service entity within the Layer 2 broadcast domain of the current BS. In this case transport MIH MAC management message (MOB MIH-MSG) is not supported by the BS.</u></p> <p><u>When bit #4 is set to be 1, MS is allowed to transmit MIH information service request MIH function frame TLV (11.20.1) in PKM-REQ.</u></p> <p><u>When bit #5 is set to be 1, MS is allowed to transmit MIH function frame TLV (11.20.1) for ES/CS Capability discovery in PKM-REQ</u></p> <p><u>Bit #0=MIH (Media Independent Handover) Capability not supported</u> <u>1=MIH Capability supported</u> <u>Bit #1 = Event Service support</u> <u>Bit #2 = Command Service support</u> <u>Bit #3 = Information Service support</u> <u>Bit #4 = Information Service support during network entry</u> <u>Bit #5 = ES/CS capability discovery support during network entry</u> <u>Bit #6~7: reserved</u></p>	<p><u>REG-REQ</u> <u>REG-RSP</u> <u>SBC-REQ</u> <u>SBC-RSP</u></p>

Remedy 3:

When bit #4 and 5 are set of MIH Capability support TLV, PKM-REQ and PKM-RSP are used to carry IEEE 802.21 information service Query or ES/CS Capability discovery MIH frame.

[In 6.3.2.3.9 Privacy key management (PKM) messages, Modify Table 26 and insert in page 13, line 17]:

Table 26-PKM message code

Code	PKM message type	MAC Management message name
...
31	<u>MIH Initial Request</u>	<u>PKM-REQ</u>
32	<u>MIH Initial Response</u>	<u>PKM-RSP</u>
33	<u>MIH Comeback Reqeust</u>	<u>PKM-REQ</u>
34	<u>MIH Comeback Response</u>	<u>PKM-RSP</u>
<u>2935~255</u>	<u>Reserved</u>	

[In 6.3.2.3.9.29 MIH Initial Unicast Query, insert in page 13, line 17]:

6.3.2.3.9.29 MIH Initial Request message

This message is sent by the MS to the BS to query using MIH function frame.

Code: 31

Attributes are shown in Table 37s

Table 37s – MIH Initial Request attributes

Attribute	Contents
<u>MIH Function Frame Type</u>	<u>Indicates type of MIH Function Frame (11.20.2)</u>
<u>Delivery Method and Status Code</u>	<u>Indicates the delivery method of query response. (11.20.4)</u>
<u>MIH Function Frame</u>	<u>MIH Function Frame TLV received through C-MIH-IND (11.20.1)</u>

6.3.2.3.9.30 MIH Initial Response

This message is sent by the BS to the MS to response to the query.

Code: 32

Attributes are shown in Table 37t

Table 37t – MIH Initial Response attributes

Attribute	Contents
<u>Cycle</u>	<u>Indicates the delivery method of query response. (11.20.2)</u>
<u>Query ID</u>	<u>Used to map query and query response (11.20.5)</u>

<u>Delivery Method and Status Code</u>	<u>Indicates the delivery method and status code. (11.20.4)</u>
--	---

6.3.2.3.9.31 MIH Comeback Request

This message is sent by the MS to the BS to retrieve query response. This message shall be only transmitted when BS polls the MS using MIH_Polling_IE in the UL-MAP.

Code: 33

Attributes are shown in Table 37u

Table 37u – MIH Comeback Request attributes

Attribute	Contents
<u>Query ID</u>	<u>Used to map query and query response (11.20.5)</u>

6.3.2.3.9.32 MIH Comeback Response

This message is sent by the BS to the MS to deliver query response.

Code: 34

Attributes are shown in Table 37v

Table 37v – MIH Initial Response attributes

Attribute	Contents
<u>MIH Function Frame Type</u>	<u>Indicates type of MIH Function Frame. Only included when MIH Function Frame is present. (11.20.2)</u>
<u>Query ID</u>	<u>Used to map query and query response (11.20.5)</u>
<u>Delivery Method and Status Code</u>	<u>Indicates the delivery method and status code. (11.20.4)</u>
<u>MIH Function Frame</u>	<u>MIH Function Frame TLV received through C-MIH-IND (11.20.1)</u>

Remedy 5:

When bit #4 and 5 are set of MIH Capability support TLV and broadcast mechanism is negotiated, SII-ADV message is used to carry Query response.

[In 6.3.2.3.63 Service Identity Information (SII-ADV) message, page14, line 41, Insert:]:

A BS may use the SII-ADV message to broadcast a list of Network Service Provider (NSP) Identifiers. The message may be broadcast periodically without solicitation or could be solicited by an (M)SS. This message is sent from the BS to all MSs on a broadcast CID. Assignment method, administration, and usage of NSP Ids are outside the scope of this standard. The BS may use the SII-ADV message to deliver IEEE 802.21 MIH function frame which carries query response. SII-ADV is broadcasted at pre-determined cycle which was notified to the MS during initial query.

[In 6.3.2.3.63 Service Identity Information (SII-ADV) message, page14, line 56, Insert:]:

The SII-ADV may contain the following TLVs:

NSP List TLV (11.1.8.1)

The NSP LIST TLV is a TLV that contains one or more Network Service Provider 24 bit Identifiers.

NSP Change Count TLV (11.1.8.2)

The NSP Change Count TLV indicates a change of the NSP list. It will be increased by one (module 256) whenever the NSP list changes.

Query ID (11.20.4)

Query ID is returned by the BS in the PKM-RSP for the MS's Query request to indicate that a backbone query through NCMS is being carried out on behalf of the MS.

MIH Function frame type (11.20.2)

MIH Function frame type TLV indicates the service type of MIH Function Frame TLV

MIH Function frame (11.20.1)

MIH Function frame TLV is used to carry MIHF Frame received through C-MIH-IND primitive from NCMS.

Remedy 4:

When bit #4 and 5 are set of MIH Capability support TLV, PKM-REQ and PKM-RSP are used to carry IEEE 802.21 information service Query or ES/CS Capability discovery MIH frame. When broadcast mechanism is negotiated SII-ADV message is used to carry Query response. During the first query message exchange, Cycle TLV is included for MS power management.

[In 11.20 MIH message encoding, page 28, line 4, Modify: Remove Name Column, Insert Scope Column]:

11.20 MIH message encodings

11.20.1 MIH Function frame

These This TLV is used to management frames carry MIHF Frame described in subclause 8.2.1 of IEEE Std 802.21 under L2 transport option-2 of Table 17, subclause 8.2. MIH function frame shall be received and transmitted using C-MIH-IND primitive from/to NCMS.

<u>Name</u>	<u>Type</u>	<u>Length</u>	<u>Value</u>	<u>Scope</u>
<u>MIHF_Frame_package</u>	??	variable	MIHF Frame described in subclause 8.2.1 of IEEE 802.21 under transport option 3 of Table 17, subcluse 8.2.	<u>MOB MIH-MSG</u> <u>PKM-REQ</u> <u>PKM-RSP</u> <u>SII-ADV</u>

11.20.2 MIH Function frame type

This TLV indicates the service type of MIH Function Frame.

<u>Type</u>	<u>Length</u>	<u>Value</u>	<u>Scope</u>
<u>??</u>	<u>1</u>	<u>0: ES/CS MIH Capability Discovery</u> <u>1: Event Service</u> <u>2: Command Service</u>	<u>MOB MIH-MSG</u> <u>PKM-REQ</u> <u>PKM-RSP</u>

		<u>3: Information Service</u> <u>4-255: Reserved</u>	<u>SII-ADV</u>
--	--	---	----------------

11.20.3 Cycle

Cycle TLV is included to indicate when Query Response is expected. MS shall only to check the cycle for the SII-ADV transmission in case of broadcast transmission method or the MIH_Polling_IE in the UL-MAP in case of unicast transmission method, and MS can switch to power saving mode while waiting for the Cycle.

<u>Type</u>	<u>Length</u>	<u>Value</u>	<u>Scope</u>
	<u>1</u>	<u>Cycle at which the Query Response may be transmitted.</u>	<u>PKM-RSP</u>

11.20.4 Delivery Method and Status Code

This TLV is included in order for MS and BS to negotiate preferred delivery method (broadcast or unicast). BS may transmit the status of the requested information. When MS include this TLV for delivery method negotiation, MS shall set the status code as to be null (0x0000).

<u>Type</u>	<u>Length</u>	<u>Value</u>	<u>Scope</u>
	<u>1</u>	<u>Bit #0: Unicast</u> <u>Bit#1: Multicast</u> <u>Bit#2~6: Status code</u> <u>0x0000: Null</u> <u>0x0001: MIH Not Supported</u> <u>0x0002: Requested Delivery Method Not Supported</u> <u>0x0003: Request Info Not Available</u> <u>0x0004: Response Not Received</u> <u>Bit#7: Reserved</u>	<u>PKM-REQ</u> <u>PKM-RSP</u>

11.20.4 Query ID

Query ID is returned by the BS in the PKM-RSP for the MS's Query request to indicate that a backbone query through NCMS is being carried out on behalf of the MS. When the MS transmit the PKM-REQ polled by MIH_Polling_IE, the MS shall use the Query ID to retrieve the response. The Query ID is included in the PKM-RSP carrying Query Response in both unicast and broadcast delivery methods.

<u>Type</u>	<u>Length</u>	<u>Value</u>	<u>Scope</u>
-------------	---------------	--------------	--------------

	<u>1</u>	<u>To be used for request to retrieve the response in the unicast mechanism. BS shall include this TLV in PKM-RSP carrying Query Response.</u>	<u>PKM-REQ</u> <u>PKM-RSP</u> <u>SII-ADV</u>
--	----------	--	--

Remedy 5:

Management CID related timer T9 Timer operation and counter Update
[In 11.4.1 DCD channel encoding, page 20, line 15, Modify]:

Table 343 – Parameters and constants

System	Name	Time reference	Minimum Value	Default Value	Maximum Value
<u>BS</u>	<u>T48</u>	<u>The time allowed between the SBC response and PKM-REQ. If the BS does not receive a PKM-REQ within the time, management CIDs shall be released.</u>			
<u>BS</u>	<u>T49</u>	<u>The time allowed between the PKM-REQ (Code=31) and PKM-REQ for security procedure initiation. If the BS does not receive a PKM-REQ which initiates the security procedure within the time, management CIDs shall be released.</u>			
<u>MS, BS</u>	<u>Query Retry Counter</u>	<u>MS: In case of broadcast method, MS shall monitor the frame at the every cycle time for transmission of SII-ADV up to the Query Retry Counter value.</u> <u>BS: In case of unicast method, BS shall poll the MS to deliver PKM-RSP carrying Query Response up to the Query Retry Counter value. If the BS does not receive a PKM-REQ (code=33) until the counter is exhausted, management CIDs shall be released.</u>	3	3	

Remedy 7:

[8.4.5.4.4.1 UL-MAP Extended IE format, page 16, line 30, Insert subsection 8.4.5.4.4.1 as it follows]:

8.4.5.4.4.1 UL-MAP Extended IE format

Table 290a. Extended UIUC Code Assignment for UIUC 15

Extended UIUC	Usage
00	Power_control_IE
...	...
<u>0B</u>	<u>MIH_Polling_IE</u>
<u>0B0C...0F</u>	Reserved

[8.4.5.4.29 MIH_Polling_IE, page 16, line 32, Insert subsection 8.4.5.4.29 as it follows]:

8.4.5.4.29 MIH Polling IE

BS's scheduling information of query response delivery is informed to the MS in the Cycle TLV of PKM-RSP (Code=32) transmitted to the MS. In case of unicast delivery method, MS shall check whether this IE is included in the UL-MAP of the frame indicated by Cycle TLV. When this IE exists in the UL-MAP, MS sends PKM-REQ (Code=33) message with Query ID TLV which was received from the BS. MS may wait for the delivery of MIH_Polling_IE until predetermined counter, Query Retry Counter, is exhausted.

Table 302z. MIH Polling IE

<u>Syntax</u>	<u>Size</u>	<u>Notes</u>
<u>MIH_Polling_IE () {</u>		
<u> Extended UIUC</u>	<u>4bits</u>	<u>MIH_Polling = 0x0B</u>
<u> Length</u>	<u>4bits</u>	
<u> Query ID</u>	<u>16bits</u>	
<u> Duration</u>	<u>10 bits</u>	<u>OFDMA slots for the uplink bandwidth</u>
<u> Reserved</u>		
<u>}</u>		