

Project	IEEE 802.16 Broadband Wireless Access Working Group < http://ieee802.org/16 >	
Title	Figure 470, comment#62	
Date Submitted	2007-01-17	
Source(s)	Aik Chindapol, Achim Brandt Siemens Networks	Achim.brandt@siemens.com
Re:		
Abstract	Change to Figures 470, section 14.1.3, page 35 – in support of comment #62	
Purpose	Adoption	
Notice	This document has been prepared to assist IEEE 802.16. It is offered as a basis for discussion and is not binding on the contributing individual(s) or organization(s). The material in this document is subject to change in form and content after further study. The contributor(s) reserve(s) the right to add, amend or withdraw material contained herein.	
Release	The contributor grants a free, irrevocable license to the IEEE to incorporate material contained in this contribution, and any modifications thereof, in the creation of an IEEE Standards publication; to copyright in the IEEE's name any IEEE Standards publication even though it may include portions of this contribution; and at the IEEE's sole discretion to permit others to reproduce in whole or in part the resulting IEEE Standards publication. The contributor also acknowledges and accepts that this contribution may be made public by IEEE 802.16.	
Patent Policy and Procedures	<p>The contributor is familiar with the IEEE 802.16 Patent Policy and Procedures (Version 1.0) <http://ieee802.org/16/ipr/patents/policy.html>, including the statement "IEEE standards may include the known use of patent(s), including patent applications, if there is technical justification in the opinion of the standards-developing committee and provided the IEEE receives assurance from the patent holder that it will license applicants under reasonable terms and conditions for the purpose of implementing the standard."</p> <p>Early disclosure to the Working Group of patent information that might be relevant to the standard is essential to reduce the possibility for delays in the development process and increase the likelihood that the draft publication will be approved for publication. Please notify the Chair <mailto:r.b.marks@ieee.org> as early as possible, in written or electronic form, of any patents (granted or under application) that may cover technology that is under consideration by or has been approved by IEEE 802.16. The Chair will disclose this notification via the IEEE 802.16 web site <http://ieee802.org/16/ipr/patents/notices>.</p>	

1 INTRODUCTION

2 Figure 470, the SAP Service Flow Diagram Template, currently is not consistent with the way how the four primitive types
3 are used throughout section 14.2. E.g. the IND primitive is in fact used in both directions etc. Comment #62 therefore
4 proposes to update Figure 470. At the same time, comment #62 aimed at adopting the standard usage of service primitive
5 types REQ, RSP, IND, CFM as defined e.g. in IEEE 802.2. Since section 14 currently applies the primitive types differently,
6 the alignment of the primitive types to that of 802.2 would cause changes to all of section 14.

7 This contribution proposes a less radical change: It includes a proposed remedy for comment#62 which is in line with the
8 current usage of the primitives in section 14.2. The current primitive types REQ, RSP, IND and ACK are maintained. Some
9 text is proposed which states the underlying primitive design rules explicitly.

10 It is proposed to accept the changes for section 14.1.3 as shown below.

11

14. Management Interfaces and Procedures

214.1 Service primitive template

- 3 1. Universal naming schema for SAP service primitive
- 4...
- 5 2. SAP service primitive object format
- 6...
- 7 3. SAP service primitive flow diagram template
- 8

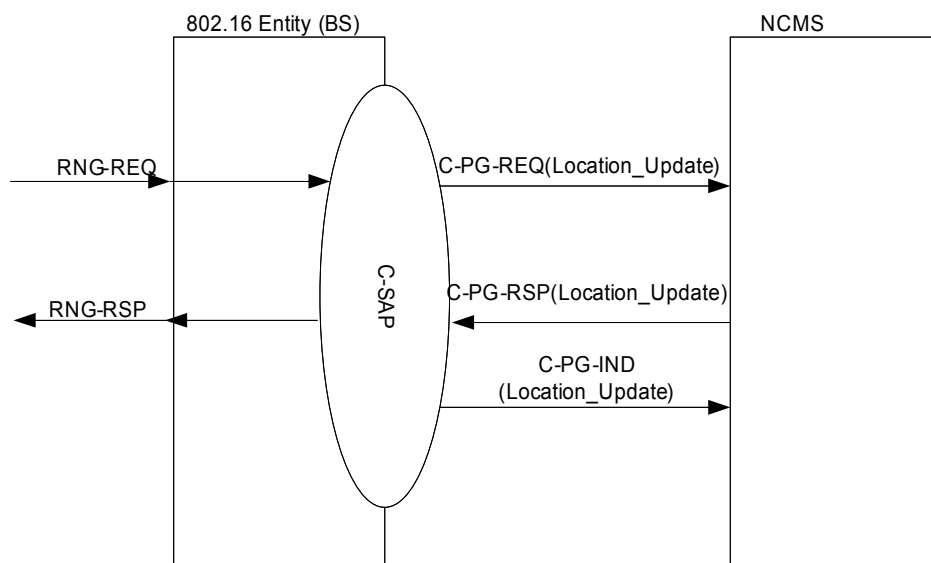

9
10
11

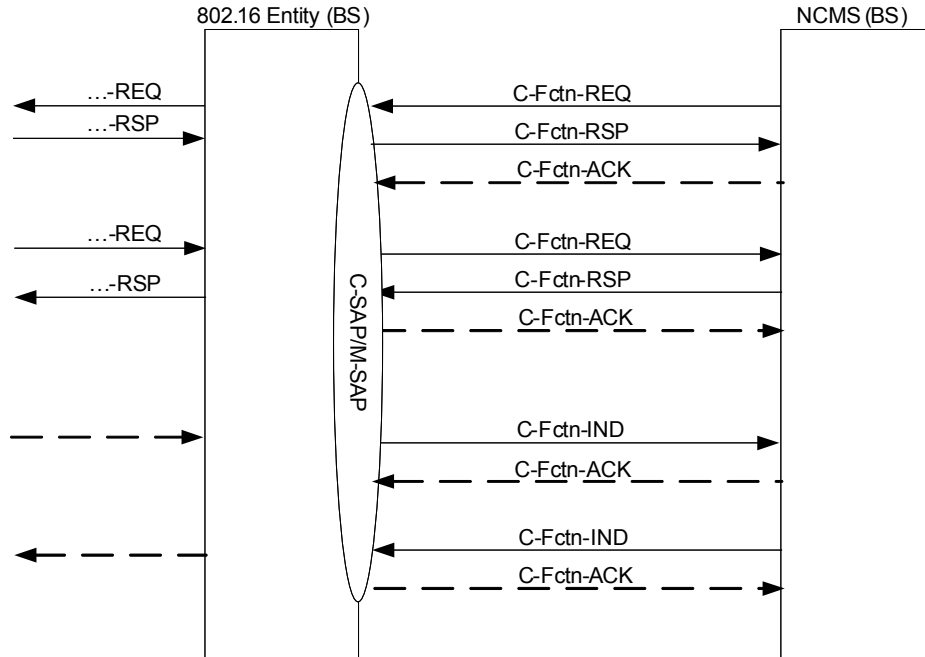

1

2

3 **Figure 470 – SAP Service primitive Flow Diagram Template. Four typical handshake scenarios shown here.**
 4 **The procedures are applicable to BS and MS side.**

5 The figure is illustrative only and provides an example of correct formatting of primitive figures.

6 The figure illustrates the following rules underlying the usage of C-SAP and M-SAP Service Primitives:

- 7 1) A service primitive of type REQ is used whenever a response to the primitive is solicited. If there is a REQ
 8 message on the radio interface, it is generally mapped to a REQ on C-SAP/M-SAP.
 9 2) A service primitive of type RSP is used in response to a REQ primitive. Moreover, if there is a RSP
 10 message on the radio interface, it is generally mapped to a RSP on C-SAP/M-SAP.
 11 3) A service primitive of type IND is used at C-SAP or M-SAP for event notification if a response to this
 12 primitive is not solicited, and if the primitive is not sent in response to a REQ primitive.
 13 4) A service primitive of type ACK can be used to acknowledge the receipt of a C-SAP primitive of type
 14 REQ, RSP or IND.

15 The specific usage of these operation types for the respective control and management functions is specified in the
 16 subsequent sections.

17

1814.2 Management and control functions