

Project	<b>IEEE 802.16 Broadband Wireless Access Working Group</b> < <a href="http://ieee802.org/16">http://ieee802.org/16</a> >
Title	<b>Amendment to Idle Mode Service Primitives</b>
Date Submitted	<b>2007-03-<del>1509</del></b>
Source(s)	Jeehyeon Na, Jaesun Cha, JungMo Moon and Sangho Lee <a href="mailto:jhna@etri.re.kr">jhna@etri.re.kr</a> ETRI 161 Gajeong-dong, Yuseong-gu Daejeon 305-700 Korea
Re:	Contribution on comments to IEEE 802.16g/D8
Abstract	Re-definition of Idle mode service primitives in section 14.2.4.2
Purpose	Adoption
Notice	This document has been prepared to assist IEEE 802.16. It is offered as a basis for discussion and is not binding on the contributing individual(s) or organization(s). The material in this document is subject to change in form and content after further study. The contributor(s) reserve(s) the right to add, amend or withdraw material contained herein.
Release	The contributor grants a free, irrevocable license to the IEEE to incorporate text contained in this contribution, and any modifications thereof, in the creation of an IEEE Standards publication; to copyright in the IEEE's name any IEEE Standards publication even though it may include portions of this contribution; and at the IEEE's sole discretion to permit others to reproduce in whole or in part the resulting IEEE Standards publication. The contributor also acknowledges and accepts that this contribution may be made public by IEEE 802.16.
Patent Policy and Procedures	The contributor is familiar with the IEEE 802.16 Patent Policy and Procedures (Version 1.0) < <a href="http://ieee802.org/16/ipr/patents/policy.html">http://ieee802.org/16/ipr/patents/policy.html</a> >, including the statement "IEEE standards may include the known use of patent(s), including patent applications, if there is technical justification in the opinion of the standards-developing committee and provided the IEEE receives assurance from the patent holder that it will license applicants under reasonable terms and conditions for the purpose of implementing the standard."  Early disclosure to the Working Group of patent information that might be relevant to the standard is essential to reduce the possibility for delays in the development process and increase the likelihood that the draft publication will be approved for publication. Please notify the Chair < <a href="mailto:r.b.marks@ieee.org">mailto:r.b.marks@ieee.org</a> > as early as possible, in written or electronic form, of any patents (granted or under application) that may cover technology that is under consideration by or has been approved by IEEE 802.16. The Chair will disclose this notification via the IEEE 802.16 web site < <a href="http://ieee802.org/16/ipr/patents/notices">http://ieee802.org/16/ipr/patents/notices</a> >.

# Amendment to Idle Mode Service Primitives

*Jeehyeon Na, Jaesun Cha, Jungmo Moon and Sangho Lee*

*ETRI*

## 1. Motivation

This contribution is to clarify the subscriber mode related function of an NCMS on an MS side and refine idle mode service primitives and figures in order to include service primitives between an MS and an NCMS on the MS side. It consists of two parts; changing of subscriber mode management and idle mode service primitives.

### 1) Motivation of changing of subscriber mode

Subscriber mode management is described as informative in section 14.2.4 and it is managed at an MS, a BS and an NCMS. Figure 479 which shows subscriber mode transition diagram at an NCMS is not clear whether for an NCMS on a BS and an MS side or not.

Therefore, we clarify figure 479 and the related texts in order to be used both NCMS at an MS and a BS side.

### 2) Motivation of changing of idle mode service primitives

In the current draft, there are defined four procedures for idle mode service primitives; idle mode initiation at an MS or an NCMS on a BS side, Paging Announce and Network re-entry. However, the service primitives between an MS and an NCMS on the MS are only defined in idle mode initiation at NCMS on the BS side.

Therefore, we propose to change figure 480, 482, 483 to the figures which are included the service primitives between an 802.16 entity (MS) and an NCMS on the MS side and modify the related service primitives parameters in this contribution. And we also correct some editorial texts.

## 2. Proposed Text Changes

[Insert the text on line 44 in page 67 as follows]

The parenthesis in figure 478 and 479 consists of condition and action for state transition, (condition, action). For example, (C-PG-REQ, C-PG-ACK) means that if an NCMS receives C-PG-REQ, it sends C-PG-ACK. If there is no action, '/' is used. For example, (C-PG-RSP, /) means that if the NCMS receives C-PG-RSP, it does not perform any action.

[Modify the text from line 62 of page 67 as follows]

Figure 479 shows Subscriber Mode transition diagram at the NCMS with service primitives related with the Subscriber Mode transition. Subscriber Mode transition from Normal Operation to Idle Mode is performed by exchanging C-PG-REQ and C-PG-RSP between ~~a BS~~ an 802.16 entity and the NCMS after successful DREG-REQ message from the MS with De-Registration Request Code=0x01 or DREG-CMD message from the BS with Action Code = 0x05, where C-PG-REQ and C-PG-RSP are defined in 14.2.4.2.1 and 14.2.4.2.2, respectively. Subscriber Mode transition from Idle Mode to Normal Operation is initiated after exchanging ~~C-PG-IND~~, C-PG-RSP, and C-PG-ACK between an 802.16 entity ~~BS~~ and the NCMS, where ~~C-PG-IND~~, C-PG-RSP, and C-PG-ACK are defined in ~~14.2.4.2.4~~, 14.2.4.2.2, and 14.2.4.2.3, respectively.

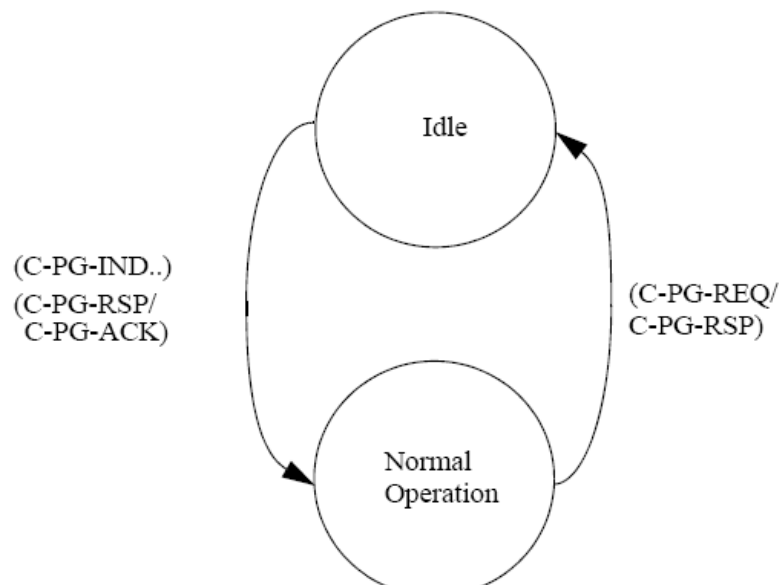

**Figure 479—Subscriber-mode transition diagram at NCMS**

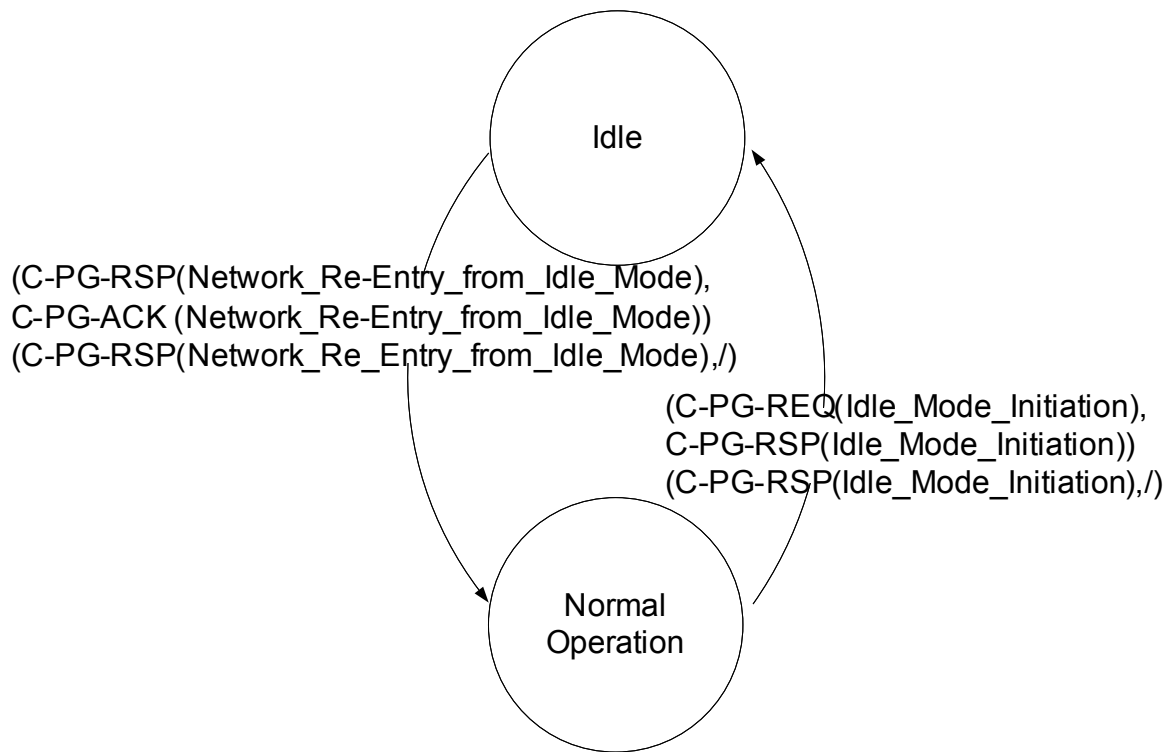

Figure 479—Subscriber mode transition diagram at NCMS [\(on BS or MS side\)](#)

[Change the figure 480 and its title to as follows]

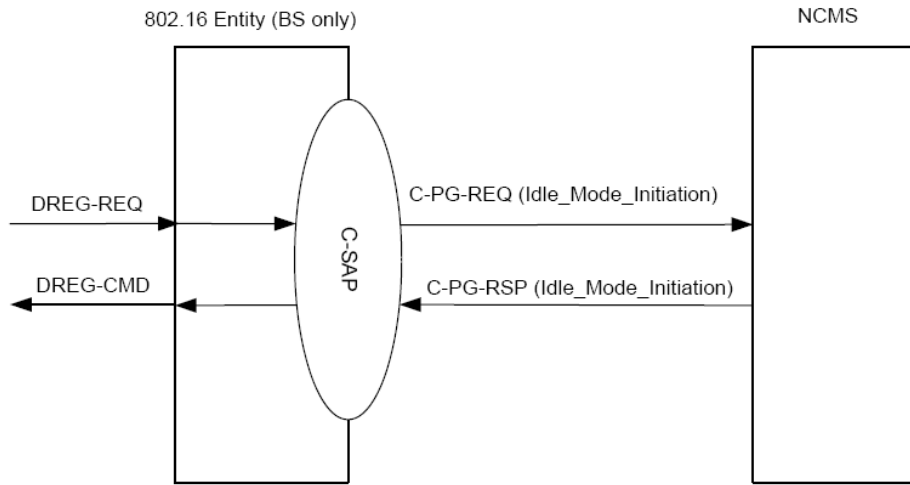

Figure 480—Idle mode initiation (MS initiated)

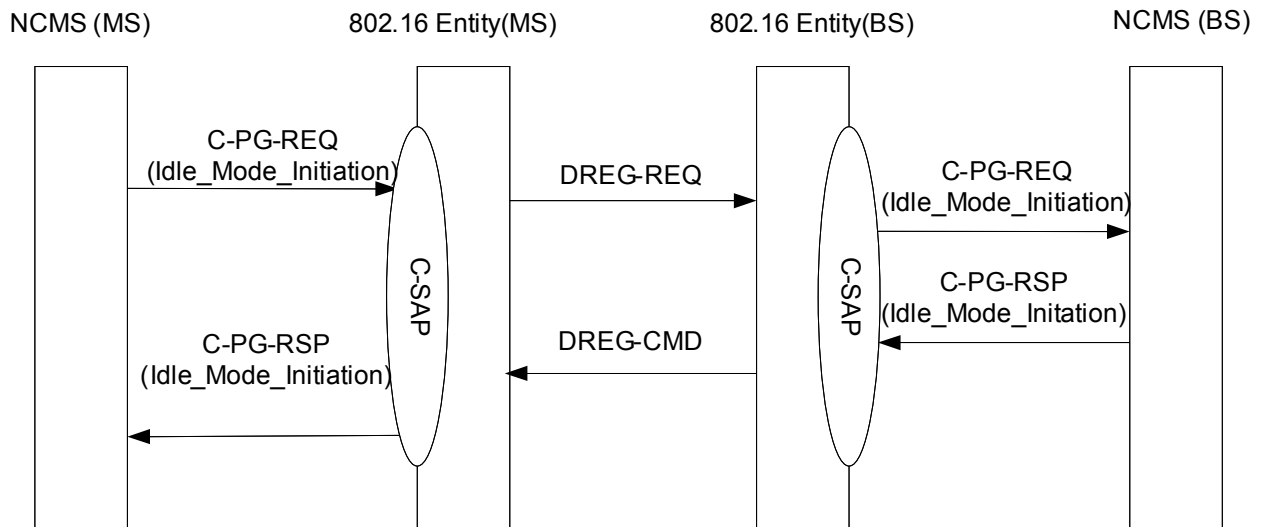

Figure 480 – Idle mode initiation (NCMS on the MS side)

[Change the figure 482 to the following figure Section 14.2.4.2 ]

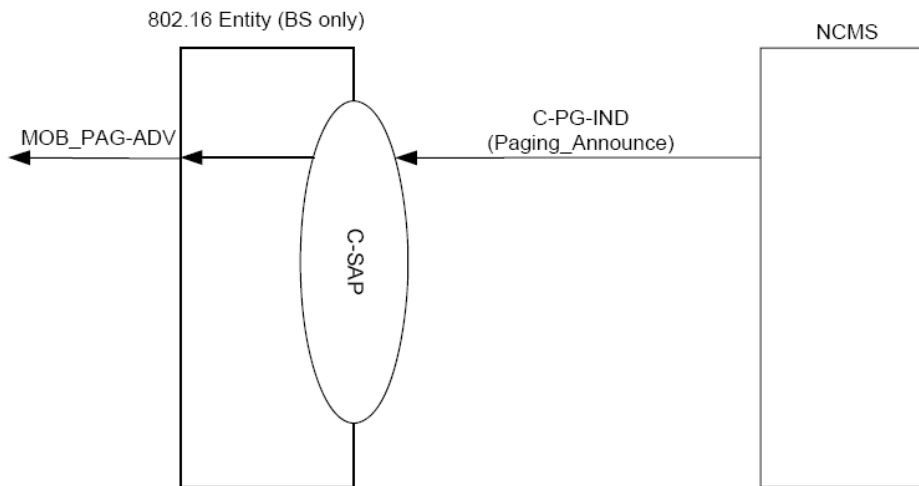

Figure 482—Paging Announcement

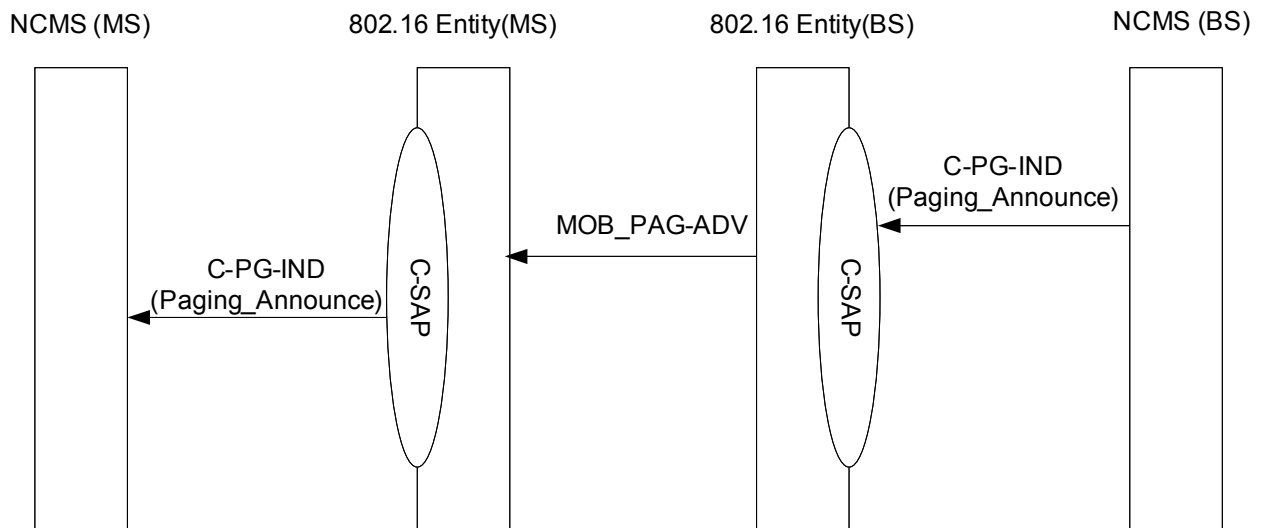

Figure 482- Paging Announcement

[Change the figure 483 to the following figure in 14.2.4.2]

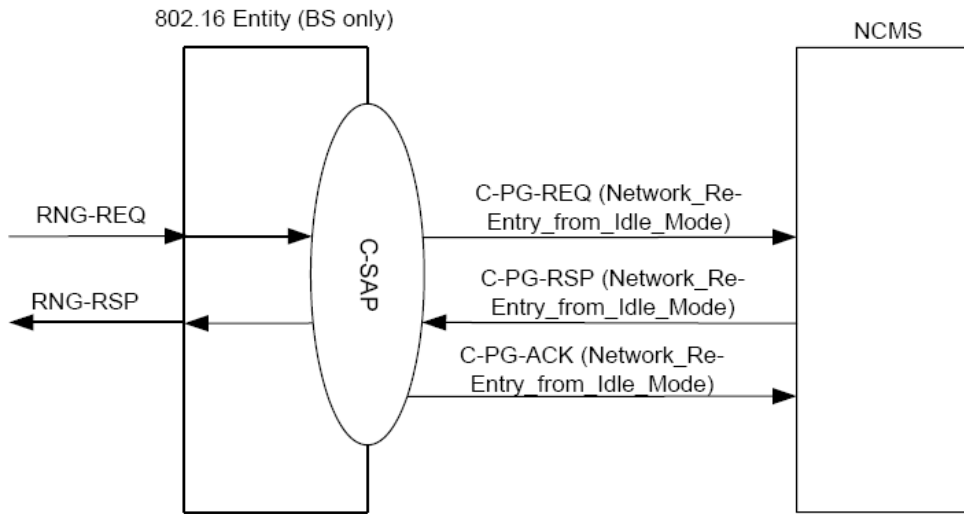

Figure 483—Network re-entry from Idle mode primitives

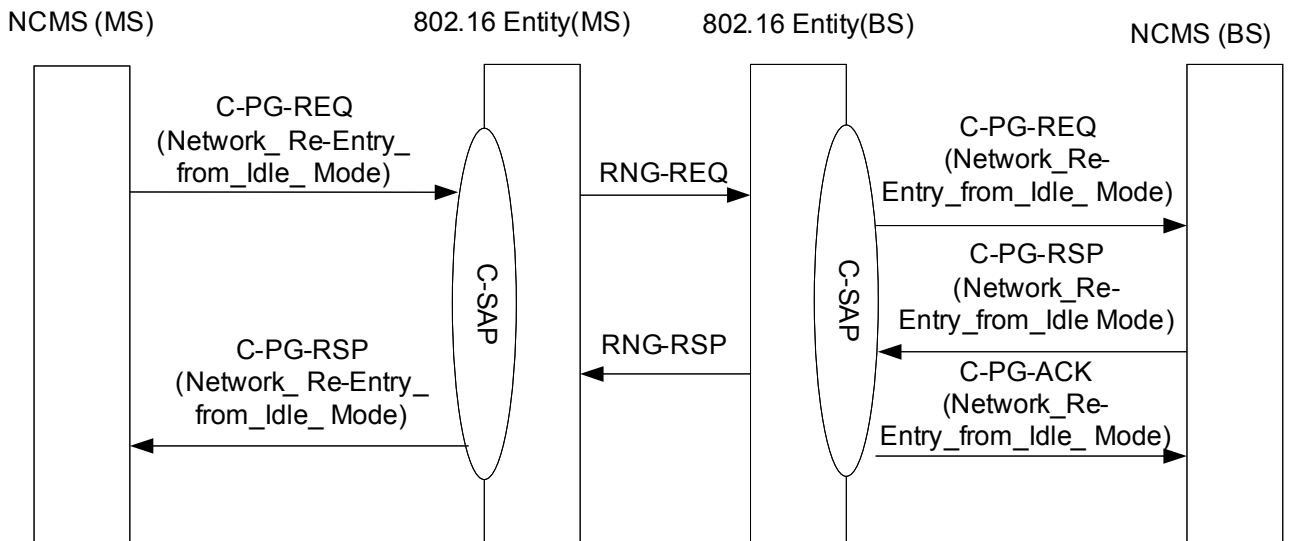

Figure 483- Network re-entry from Idle mode primitives

[Modify Subclause 14.2.4.2.1 as follows ]

#### 14.2.4.2.1 C-PG-REQ

This primitive is used by an 802.16 entity or [an NCMS](#) to trigger an idle mode service procedure. The Operation\_Type included in this primitive defines the type of idle mode service procedure to be performed. The possible Operation\_Types for this primitive are listed in Table below.

Operation Type	Action_Type	Description
Action	<del>Idle Mode Initiation</del> <a href="#">Idle Mode Initiation</a>	Idle Mode Initiation Request
Action	<del>Network Re-Entry from Idle Mode</del> <a href="#">Network Re-Entry from Idle Mode</a>	Network Re-Entry from Idle Mode Request

[*Modify Subclause 14.2.4.2.1.1 as follows* ]

##### 14.2.4.2.1.1 C-PG-REQ (Action\_Type = Idle\_Mode\_Initiation)

###### Function:

This primitive is issued by [an NCMS \(MS or BS\)](#) ~~a BS~~ to [initiate idle mode](#) ~~inform the Paging and Idle Mode Services entity in the NCMS that an MS requests to initiate Idle Mode. This primitive can also be issued by the NCMS to force MS into an Idle mode by instructing the BS to initiate a DREG-CMD to the MS with Action Code=0x05.~~

###### Semantics of the service primitive:

The parameters of the primitive are as follows:

###### C-PG-REQ

```
(
  Operation_Type: Action,
  Action_Type: Idle_Mode_Initiation,
  Destination: NCMS, BS, MS,
  Attribute_List:
    MS MAC Address,
    Paging_Information,
    Paging_Controller_ID,
    Security_Information,
    Idle_Mode_Retain_Information,
    MAC_Hash_Skip_Threshold,
    Service_Flow_parameters,
    Service_and_operational_information
)
```

###### MS MAC Address

48-bit MAC Address which identifies MS during Idle Mode

###### Paging\_Information

Paging Group ID, Paging Cycle, Paging Offset

###### Paging\_Controller\_ID

A logical network identifier for the serving BS or other network entity retaining MS service and operational information and/or administrating paging activity for the MS while in Idle Mode. The Paging Controller ID shall be set to the BSID when a BS is **acting as the Paging Controller**.

###### Security\_Information

AK Context, security association info, authenticator ID, etc.

###### Idle\_Mode\_Retain\_Information



MS request for Paging Controller retention of MS service and operational information to expedite future Network Re-entry from Idle Mode. (see 6.3.2.3.42.)

**MAC Hash Skip Threshold**

Maximum number of successive MOB\_PAG-ADV messages that may be sent from a BS individual notification for an MS, including MS MAC Address Hash of an MS for which Action Code is 0b00, 'No Action Required'.

**Service Flow parameters**

Parameters for the existing Service Flow without actually activating it to carry traffic at MS Idle Mode Initiation, e.g. Paging Preference.

**Service and operational information**

MS service and operational information associated with MAC state machines, CS classifier information, etc.

**When generated:**

~~This primitive is generated when a BS receives a DREG-REQ message with Deregistration\_Request\_Code=0x01, "request for MS De-Registration from serving BS and initiation of MS Idle Mode".~~

~~- NCMS (MS) -> 802.16 entity (MS)~~

~~This primitive is generated by an NCMS (MS) when the NCMS(MS) decides on Idle mode initiation.~~

~~- 802.16 entity(BS) -> NCMS (BS)~~

~~This primitive is generated by an 802.16 entity (BS) when the 802.16 entity(BS) receives MAC messages for initiation of idle mode (DREG-REQ with Deregistration\_Request\_Code=0x01, "request for MS De-Registration from serving BS and initiation of MS Idle Mode")~~

~~- NCMS (BS) -> 802.16 entity (BS)~~

~~This primitive is generated by an NCMS (BS) when the NCMS(BS) decides on Idle mode initiation.~~

~~- 802.16 entity(SS) -> NCMS (SS)~~

~~This primitive is generated by an 802.16 entity (SS) when the 802.16 entity(SS) receives MAC messages for initiation of idle mode (DREG-CMD with Action Code = 0x05)~~

**Effect of receipt:**

~~This primitive shall be generated on the BS side and the Paging and Idle Mode Services entity shall respond to this primitive by sending C-PG-RSP(Idle\_Mode\_Initiation).~~

~~- NCMS (MS) -> 802.16 entity (MS)~~

~~When the 802.16 entity(MS) receives the C-PG-REQ, the MS shall transmit DREG-REQ with Deregistration\_Request\_Code=0x01.~~

~~- 802.16 entity(BS) -> NCMS (BS)~~

~~The NCMS shall respond to this primitive with C-PG-RSP(Idle\_Mode\_Initiation) and performs idle mode initiation procedure.~~

~~- NCMS (BS) -> 802.16 entity (BS)~~

~~When the 802.16 entity(BS) receives the C-PG-REQ, the BS shall transmits DREG-CMD with Action Code = 0x05~~

~~- 802.16 entity(SS) -> NCMS (SS)~~

~~The NCMS responds to this primitive with C-PG-RSP(Idle\_Mode\_Initiation) and performs idle mode initiation procedure.~~

**14.2.4.2.1.2 C-PG-REQ (Action\_Type = Network re-entry from Idle mode Network\_Re-Entry\_from\_Idle\_Mode)**

**Function:**

This primitive is issued by [an NCMS on an MS](#) a BS to inform ~~the Paging and Idle Mode Services entity of Paging Services~~ [an 802.16 entity](#) that the ~~specified~~ MS is attempting to re-enter network ~~in response to paging~~.

### Semantics of the service primitive:

The parameters of the primitive are as follows:

#### C-PG-REQ

```
(
  Operation_Type: Action,
  Action_Type: Network_Re-Entry_from_Idle_Mode,
  Destination: MS\_NCMS,
  Attribute_List:
    MS MAC Address,
    Paging Information,
    Paging Controller ID,
    BSID
)
```

#### MS MAC Address

48-bit MAC Address which identifies MS during Idle Mode

#### Paging Information

Paging Group ID, Paging Cycle, and Paging Offset parameters followed used by MS in Idle Mode.

#### Paging Controller ID

A logical network identifier for the serving BS or other network entity retaining MS service and operational information and/or administrating paging activity for the MS while in Idle Mode. The Paging Controller ID shall be set to the BSID when a BS is acting as the Paging Controller.

#### BSID

A network identifier of the BS at which the MS is attempting to re-enter network

### When generated:

~~This primitive is generated by a BS when it receives a RNG-REQ message including Ranging Purpose Indication with setting bit #0 to 1 in combination with Paging Controller ID.~~

~~- NCMS (MS) -> 802.16 entity (MS)~~

~~This primitive is generated by an NCMS (MS) when the NCMS(MS) performs network re-entry.~~

~~- 802.16 entity(BS) -> NCMS (BS)~~

~~This primitive is generated by an 802.16 entity(BS) when it receives a RNG-REQ message including Ranging Purpose Indication with setting bit #0 to 1 in combination with Paging Controller ID.~~

### Effect of receipt:

~~C-PG-REQ(Network\_Re-Entry\_from\_Idle\_Mode) notifies the Paging and Idle Mode Services entity that the specified MS is attempting to re-enter network through the specified BS in order to receive DL traffic. The management entity also checks the MS service and operational information for the MS, and transmits C-PG-RSP(Network\_Re-Entry\_from\_Idle\_Mode) in response to this primitive.~~

~~- NCMS (MS) -> 802.16 entity (MS)~~

~~If an 802.16 entity(MS) receives C-PG-REQ(Network\_Re-Entry\_from\_Idle\_Mode), it shall generate with RNG-REQ to a BS.~~

~~- 802.16 entity(BS) -> NCMS (BS)~~

~~If an NCMS(BS) receives C-PG-REQ(Network\_Re-Entry\_from\_Idle\_Mode), it shall respond to the request with C-PG-RSP(Network\_Re-Entry\_from\_Idle\_Mode) primitive~~

[Modify Subclause 14.2.4.2.2 as follows ]

#### 14.2.4.2.2 C-PG-RSP

This primitive is used by an 802.16 entity or NCMS to respond to an idle mode service request. The Operation\_Type included in this primitive defines the type of idle mode service procedure to be performed. The possible Operation\_Types for this primitive are listed in Table below:

Operation Type	Action Type	Description
Action	- <del>Idle Mode Initiation</del> <a href="#">Idle_Mode_Initiation</a>	Idle Mode Initiation Request
Action	- <del>Network Re-entry from Idle Mode</del> <a href="#">Network_Re-Entry_from_Idle_Mode</a>	Network Re-Entry from Idle Mode Request

#### 14.2.4.2.2.1 C-PG-RSP (Action\_Type = Idle\_Mode\_Initiation)

##### Function:

This primitive is issued by the Paging and Idle Mode Services entity in the NCMS in response to the C-PG-REQ(Idle\_Mode\_Initiation) primitive.

##### Semantics of the service primitive:

The parameters of the primitive are as follows:

##### C-PG-RSP

```
(
  Operation_Type: Action,
  Action_Type: Idle_Mode_Initiation,
  Destination: NCMS, BS, MS,
  Attribute_List:
    Action code,
    MS MAC Address,
    Paging Information,
    Paging Controller ID,
    Idle Mode Retain Information,
    MAC Hash Skip Threshold,
    REQ-duration
)
```

##### Action code

Indicates the value of Action code to be included in DREQ-CMD message. (see Table 55.)

##### MS MAC Address

48-bit MAC Address which identifies MS during Idle Mode

##### Paging Information

Paging Group ID, Paging Cycle, and Paging Offset parameters followed by MS in Idle Mode.

##### Paging Controller ID

A logical network identifier for the serving BS or other network entity retaining MS service and operational information and/or administrating paging activity for the MS while in Idle Mode. The Paging Controller ID shall be set to the BSID when a BS is acting as the Paging Controller.

##### Idle Mode Retain Information

MS request for Paging Controller retention of MS service and operational information to expedite future Network Re-entry from Idle Mode. (see 6.3.2.3.42.)

##### MAC Hash Skip Threshold

Maximum number of successive MOB\_PAG-ADV messages that may be sent from a BS individual notification for an MS, including MS MAC Address Hash of an MS for which Action Code is 0b00, 'No Action Required'.

##### REQ-duration

Waiting value for the DREG-REQ message re-transmission (measured in frames).

##### When generated:

~~This primitive is generated to request a BS to issue a DREG-CMD message.~~

- NCMS (BS) -> 802.16 entity (BS)

This primitive is generated by the NCMS(BS) to request a 802.16 entity(BS) to issue a DREG-CMD message after receiving C-PG-REQ(Idle\_Mode\_Initiation).

- 802.16 entity(MS) -> NCMS (MS)

This primitive is generated by an 802.16 entity(MS) to inform result of idle mode initiation.

- NCMS (MS) -> 802.16 entity (MS)

This primitive is generated by the NCMS(MS) to request a 802.16 entity(MS) to issue a DREG-REQ message after receiving C-PG-REQ(Idle\_Mode\_Initiation).

- 802.16 entity(BS) -> NCMS (BS)

This primitive is generated by an 802.16 entity(BS) to inform result of idle mode initiation.

### Effect of receipt:

~~A BS receiving C-PG-RSP(Idle\_Mode\_Initiation) shall transmit DREG-CMD message with setting each field in accordance with the information elements in this primitive.~~

- NCMS (BS) -> 802.16 entity (BS)

When the 802.16 entity(BS) receives C-PG-RSP(Idle\_Mode\_Initiation), the BS transmits DREG-CMD message with setting each field in accordance with the information elements in this primitive.

- 802.16 entity(MS) -> NCMS (MS)

The NCMS(MS) completes idle mode initiation

- NCMS (MS) -> 802.16 entity (MS)

When the 802.16 entity(MS) receives C-PG-RSP(Idle\_Mode\_Initiation), the MS transmits DREG-REQ message with setting each field in accordance with the information elements in this primitive.

- 802.16 entity(BS) -> NCMS (BS)

The NCMS(MS) completes idle mode imitation.

#### 14.2.4.2.2.2 C-PG-RSP (Action\_Type = **Network re-entry from Idle mode** Network\_Re-Entry\_from\_Idle\_Mode)

### Function:

This primitive is issued by the Paging and Idle Mode Services entity to confirm the MS Network Re-entry from Idle Mode and provide the BS, at which the MS is attempting to re-enter the network, with service and operational information.

### Semantics of the service primitive:

The parameters of the primitive are as follows:

#### **C-PG-RSP**

(  
 Operation\_Type: Action,  
 Action\_Type: Network\_Re-Entry\_from\_Idle\_Mode,  
 Destination: BS, NCMS,  
 Attribute\_List:  
   MS MAC Address,  
   Security Information,  
   Service and operational information,  
 )

#### **MS MAC Address**

48-bit MAC Address which identifies MS during Idle Mode

#### **Security Information**

AK Context, Security Association Info, Authenticator ID, etc.

#### **Service and operational information**

MS service and operational information associated with MAC state machines, CS classifier information, etc.

### When generated:

~~This primitive is generated by BS when a RNG-REQ message including Ranging Purpose Indication with~~

~~setting bit #0 to 1 in combination with Paging Controller ID.~~

~~- NCMS (BS) -> 802.16 entity (BS)~~

~~This primitive is generated by the NCMS(BS) to respond C-PG-REQ(Network\_Re-Entry\_from\_Idle\_Mode).~~

~~- 802.16 entity(MS) -> NCMS (MS)~~

~~This primitive is generated by an 802.16 entity(MS) to inform result of network re-entry.~~

### Effect of receipt:

~~BS receiving C-PG-RSP(Network\_Re-Entry\_from\_Idle\_Mode) transmits RNG-RSP message including HO-Process Optimization which is based on the service and operational information in this primitive. The BS acknowledges the receipt of this message by transmitting the C-PG-ACK(Network\_Re-Entry\_from\_Idle\_Mode) message to the NCMS.~~

~~- NCMS (BS) -> 802.16 entity (BS)~~

~~When the 802.16 entity(BS) receives C-PG-RSP(Network\_Re-Entry\_from\_Idle\_Mode), the BS shall transmit RNG-RSP message with setting each field in accordance with the information elements in this primitive. The BS acknowledges the receipt of this message by transmitting the C-PG-ACK(Network\_Re-Entry\_from\_Idle\_Mode) message to the NCMS.~~

~~- 802.16 entity(MS) -> NCMS (MS)~~

~~The NCMS(MS) completes network re-entry.~~

**[Modify from 45 line on page 76 to 11 line on page 77 in section 14.2.4.2.4 as follows ]**

### C-PG-IND

(  
     Event\_Type: Paging Announce,  
     Destination: BS, NCMS  
     Attribute\_List:  
         MS MAC Address,  
         Paging Information,  
         Action Code  
 )

MS MAC Address

48-bit MAC Address which identifies MS during Idle Mode

Paging Information

Paging Group ID, Paging Cycle, and Paging Offset parameters followed by MS in Idle Mode.

Action Code

Action required for MS in Idle Mode (e.g. Network Re-entry, ranging for location update, and so on)

### When generated:

~~- NCMS (BS) -> 802.16 entity (BS)~~

~~This primitive is generated by the Paging and Idle Mode Services entity to request a BS to transmit BS Broadcast Paging message.~~

~~- 802.16 entity(MS) -> NCMS (MS)~~

~~This primitive is generated by the 802.16 entity (MS) to inform paging announce.~~

### Effect of receipt:

~~- NCMS (BS) -> 802.16 entity (BS)~~

~~A BS receiving C-PG-IND (Paging\_Announce) shall transmit MOB\_PAG-ADV message following the information provided by this primitive.~~

~~- 802.16 entity(MS) -> NCMS (MS)~~

~~The NCMS(MS) shall perform C-PG-IND(Paging\_Announce).~~