

Discussion of MMR Protocol Stack

Document Number:

IEEE C802.16j-06/076r1

Date Submitted:

2006-07-12

Source:

Hang Zhang, Wen Tong, Peiyong Zhu, Mohan Fong
Gamini Senarnath, David Steer, Derek Yu, Wang G-Q
Jose Costa
Nortel, 3500 Carling Avenue
Ottawa, On K2H 8E9 Canada

Voice: 613 7631315

E-mail: hazhang@nortel.com; wentong@nortel.com

Dean Kitchener, Mark Naden
Nortel
London Road
Harlow, Essex, CM17 9NA

Venue:

IEEE 802.16 Session #44, San Diego, USA

Base Document: C80216j-06_041: "Harmonized definitions and terminology for Mobile Multihop Relay"

Purpose:

[To introduce and clarify the terminologies of R-DL, R-UL, R-PHY and R-MAC](#)

Notice:

This document has been prepared to assist IEEE 802.16. It is offered as a basis for discussion and is not binding on the contributing individual(s) or organization(s). The material in this document is subject to change in form and content after further study. The contributor(s) reserve(s) the right to add, amend or withdraw material contained herein.

Release:

The contributor grants a free, irrevocable license to the IEEE to incorporate material contained in this contribution, and any modifications thereof, in the creation of an IEEE Standards publication; to copyright in the IEEE's name any IEEE Standards publication even though it may include portions of this contribution; and at the IEEE's sole discretion to permit others to reproduce in whole or in part the resulting IEEE Standards publication. The contributor also acknowledges and accepts that this contribution may be made public by IEEE 802.16.

IEEE 802.16 Patent Policy:

The contributor is familiar with the IEEE 802.16 Patent Policy and Procedures <http://ieee802.org/16/ipr/patents/policy.html>, including the statement "IEEE standards may include the known use of patent(s), including patent applications, provided the IEEE receives assurance from the patent holder or applicant with respect to patents essential for compliance with both mandatory and optional portions of the standard." Early disclosure to the Working Group of patent information that might be relevant to the standard is essential to reduce the possibility for delays in the development process and increase the likelihood that the draft publication will be approved for publication. Please notify the Chair <mailto:chair@wirelessman.org> as early as possible, in written or electronic form, if patented technology (or technology under patent application) might be incorporated into a draft standard being developed within the IEEE 802.16 Working Group. The Chair will disclose this notification via the IEEE 802.16 web site <http://ieee802.org/16/ipr/patents/notices>.

Introduction and Background

- Based on IEEE802.16j PAR, in order to achieve backward compatibility, we propose to retain the IEEE802.16e-2005 protocol stack by defining two new sub-layers for MMR-BS and RS:
 - R-MAC
 - R-PHY
 - Both are interoperable with IEEE802.16e-2005
- We also retain the DL and UL PHY/MAC format intact for the connectivity with MS to achieve zero change on IEEE802.16e-2005 MS
- The link for MMR-BS \leftrightarrow RS and RS \leftrightarrow RS are defined based on basic DL and UL with additional functionality and enhancement:
 - R-DL
 - R-UL

MMR Protocol Stack

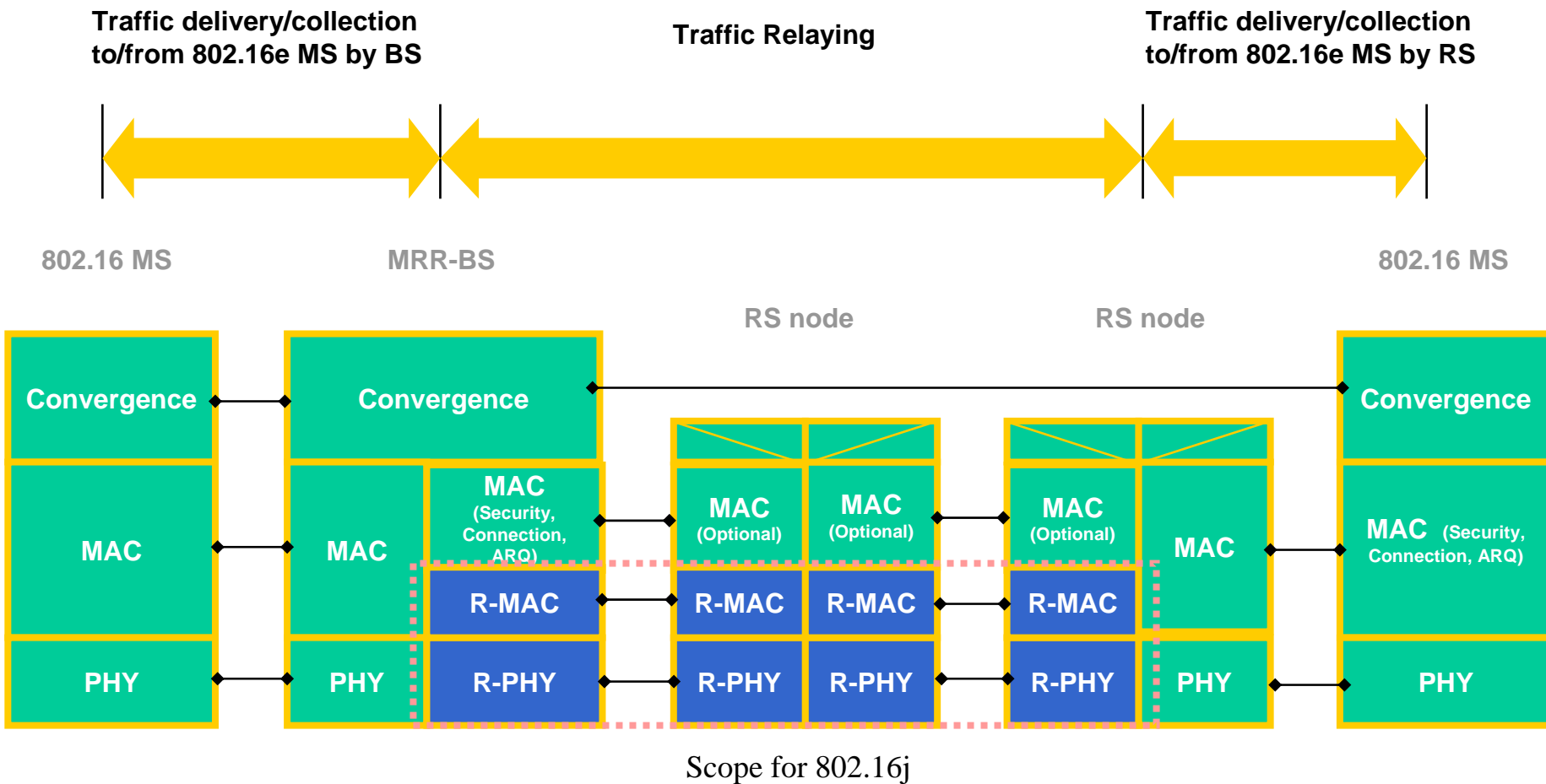

MMR protocol Stack: R-PHY and R-MAC

- Modify physical layer if needed: R-PHY sub-layer between
 - MMR-BS \leftrightarrow RS
 - RS \leftrightarrow RS
 - It uses current 802.16e-2005 PHY as baseline
 - It may be the enhanced 802.16e-2005 PHY
- Introduce a new MAC sub-layer: R-MAC sub-layer between
 - MMR-BS \leftrightarrow RS
 - RS \leftrightarrow RS
- Retain E2E 802.16e security
 - between MMR-BS \leftrightarrow MS
- Retain E2E 802.16e connection
 - between MMR-BS \leftrightarrow MS
- Retain E2E 802.16e ARQ
 - between MMR-BS \leftrightarrow MS
- Retain and support per-link HARQ
- Access RS implements the complete 802.16e MAC functionality
- Relaying path RSs implements partial 802.16e MAC functionality

MMR Architecture – Link Level

- IEEE802.16j MMR basic link connectivity can be defined as:

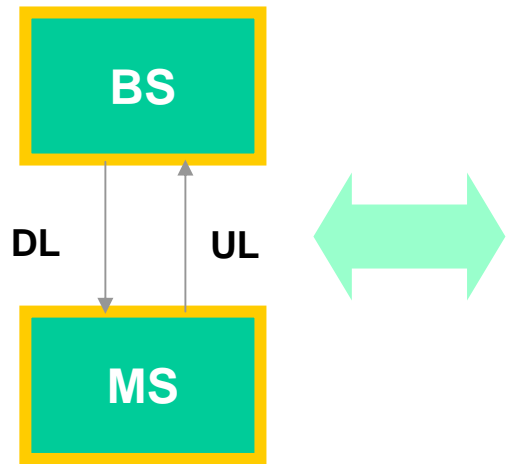

IEEE802.16e-2005

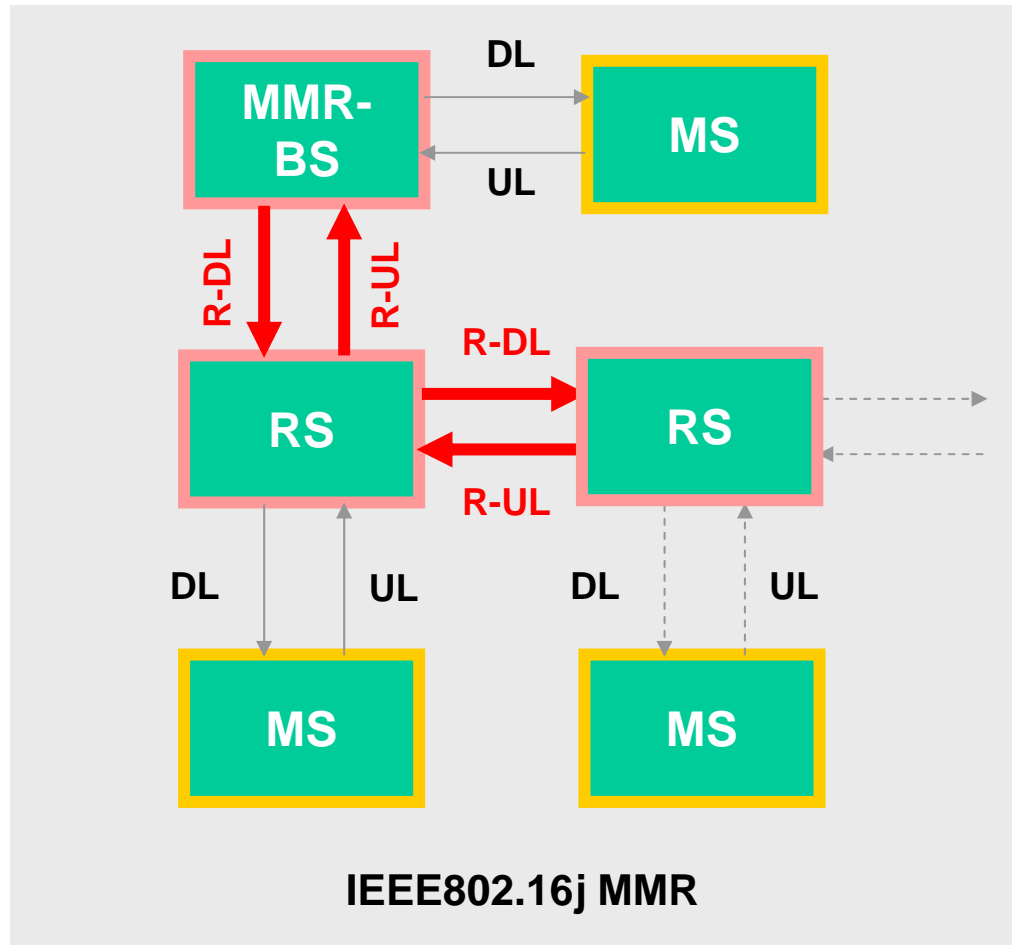

MMR Architecture – Path Level

- IEEE802.16j MMR basic path connectivity can be defined as:

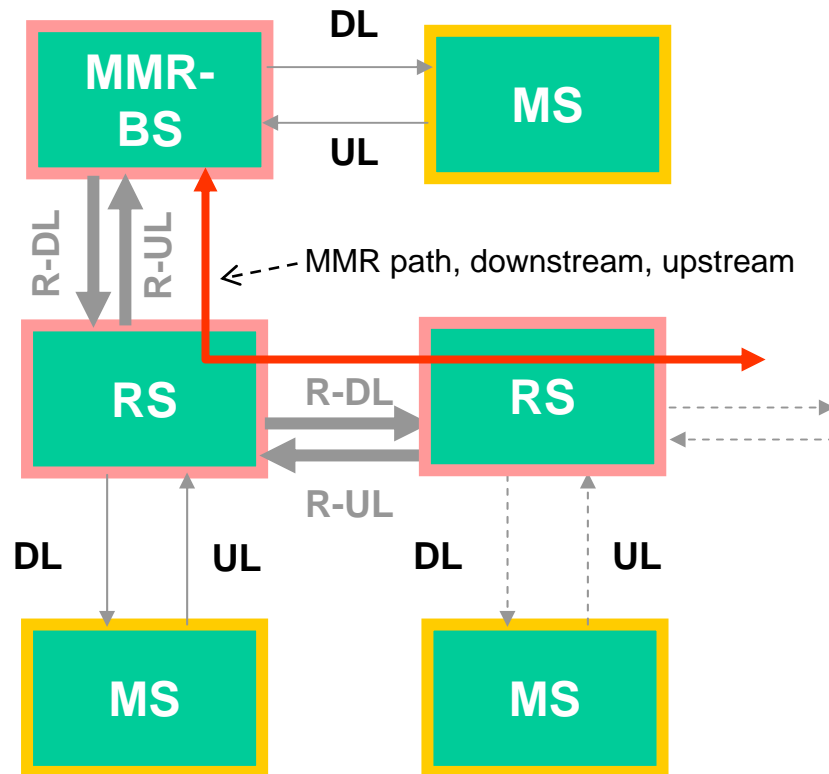

IEEE802.16j MMR

MMR Links: R-DL and R-UL

- Based on IEEE802.16j PAR, the legacy MS operation is not allowed to be changed, therefore,
- The link for MS namely the DL and UL can not be modified:
 - We propose to retain the terminology as IEEE802.16e-2005
- The links for MMR-BS \leftrightarrow and RS \leftrightarrow RS are defined as:
 - R-DL and R-UL,
- The relationship of DL/UL and R-DL/R-UL can be described as:

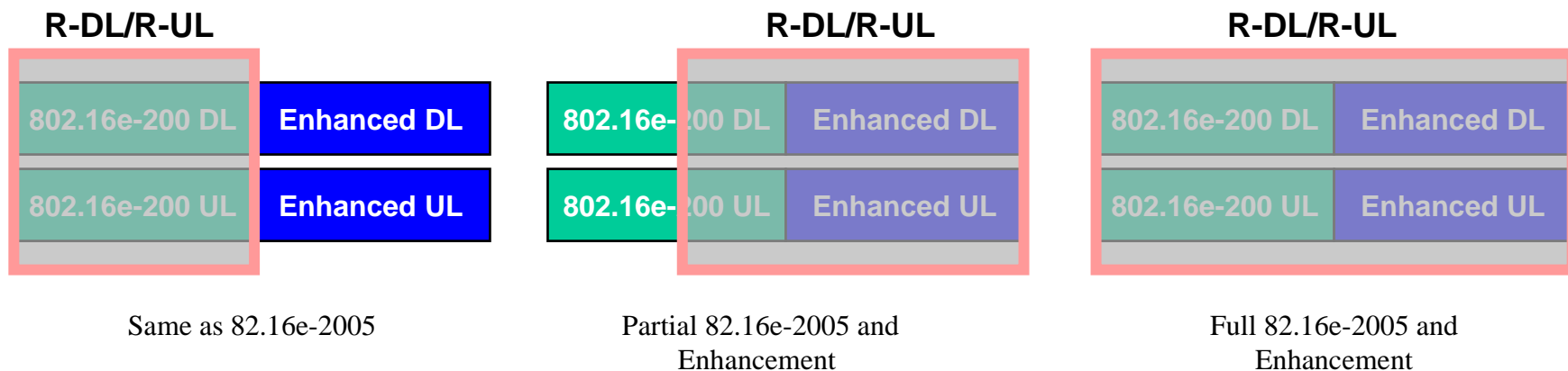

Text Proposal

- **R-MAC**
“MAC sub-layer to support multi-hop relay”
- **R-PHY**
“Physical sub-layer to support multi-hop relay”
- **R-DL**
“Down link between the MMR-BS and RS nodes or between RSs nodes for downstream relay”
- **R-UL**
“Up link between the MMR-BS and RS nodes or between RSs nodes for upstream relay”
- **MMR path**
“Concatenation of k consecutive relay links ($k \geq 1$) between the MMR-BS and the designated access RS”
- **Downstream Traffic**
“data flow to be relayed from MMR-BS to targeting MS”
- **Upstream Traffic**
“data flow to be relayed from MS to targeting MMR-BS”