

Project	IEEE 802.16 Broadband Wireless Access Working Group < <a href="http://ieee802.org/16">http://ieee802.org/16</a> >	
Title	[Scheduling Service and Distributed Scheduling for 802.16j system]	
Date Submitted	[2006-11-07]	
Source(s)	Yanling Lu, Ting Li, Shulan Feng Hisilicon Technologies [Harbour Building, No.8, Dongbeiwang West Road,] [HaiDian District, Beijing, China]	Voice: [86-10-82829010] Fax: [86-10-82829010] [mailto:luyanling@hisilicon.com]
Re:	This contribution is a response to " IEEE 802.16j-06/027 Call for Technical Proposals regarding IEEE Project 802.16j" (2006-10-15) .	
Abstract	This contribution described the proposed distributed scheduling in 802.16j system.	
Purpose	This document is provided in response for Call for Technical Proposals regarding IEEE Project 802.16j .	
Notice	This document has been prepared to assist IEEE 802.16. It is offered as a basis for discussion and is not binding on the contributing individual(s) or organization(s). The material in this document is subject to change in form and content after further study. The contributor(s) reserve(s) the right to add, amend or withdraw material contained herein.	
Release	The contributor grants a free, irrevocable license to the IEEE to incorporate material contained in this contribution, and any modifications thereof, in the creation of an IEEE Standards publication; to copyright in the IEEE's name any IEEE Standards publication even though it may include portions of this contribution; and at the IEEE's sole discretion to permit others to reproduce in whole or in part the resulting IEEE Standards publication. The contributor also acknowledges and accepts that this contribution may be made public by IEEE 802.16.	
Patent Policy and Procedures	The contributor is familiar with the IEEE 802.16 Patent Policy and Procedures < <a href="http://ieee802.org/16/ipr/patents/policy.html">http://ieee802.org/16/ipr/patents/policy.html</a> >, including the statement "IEEE standards may include the known use of patent(s), including patent applications, provided the IEEE receives assurance from the patent holder or applicant with respect to patents essential for compliance with both mandatory and optional portions of the standard." Early disclosure to the Working Group of patent information that might be relevant to the standard is essential to reduce the possibility for delays in the development process and increase the likelihood that the draft publication will be approved for publication. Please notify the Chair < <a href="mailto:chair@wirelessman.org">mailto:chair@wirelessman.org</a> > as early as possible, in written or electronic form, if patented technology (or technology under patent application) might be incorporated into a draft standard being developed within the IEEE 802.16 Working Group. The Chair will disclose this notification via the IEEE 802.16 web site < <a href="http://ieee802.org/16/ipr/patents/notices">http://ieee802.org/16/ipr/patents/notices</a> >.	

## **Scheduling Service and Distributed Scheduling for 802.16j system**

Yanling Lu , Ting Li, Shulan Feng

Hisilicon Technologies  
Harbour Building, No.8, Dongbeiwang West Road,  
HaiDian District, Beijing, China

### **Introduction**

In the 802.16j system, k-hop link ( $k > 1$ ) leads to more delay time of traffic transfer. In this document, a technical solution is proposed to accelerate traffic transfer.

### **Proposed distributed scheduling in 802.16j**

In 802.16j system, when one RS be able to schedule the uplink bandwidth, distributed scheduling may be used.

Assuming in 802.16j system it takes out-of-band relay frame structure and the MMR-BS decides to set up one service flow on the k-hop link between the MMR-BS and one MS , who is k-hop away from the MMR-BS, some optimization mechanism should be taken.

#### **One example:**

To create UGS service, obeying the rule of 802.16e, the MMR-BS and RSs along link between the MMR-BS and this MS should grant fixed size bandwidth to its next hop node on the real-time periodic basis. If the MMR-BS and RSs grant the bandwidth fully independently, it comes on the following:

After UGS data arrives at a RS, however, the RS has no adequate uplink bandwidth to send UGS data. This RS should storage these UGS data until it gets the bandwidth granted to itself. As an extreme case, if the MMR-BS and RSs grant the bandwidth at the same time , the granting frequency is one time per  $f$  frame and the MS is  $k$  hop away from the MMR-BS, then the delay time between the MS sending UGS data and the MMR-BS receiving the same UGS data is  $f \cdot (k-1)$  frame.

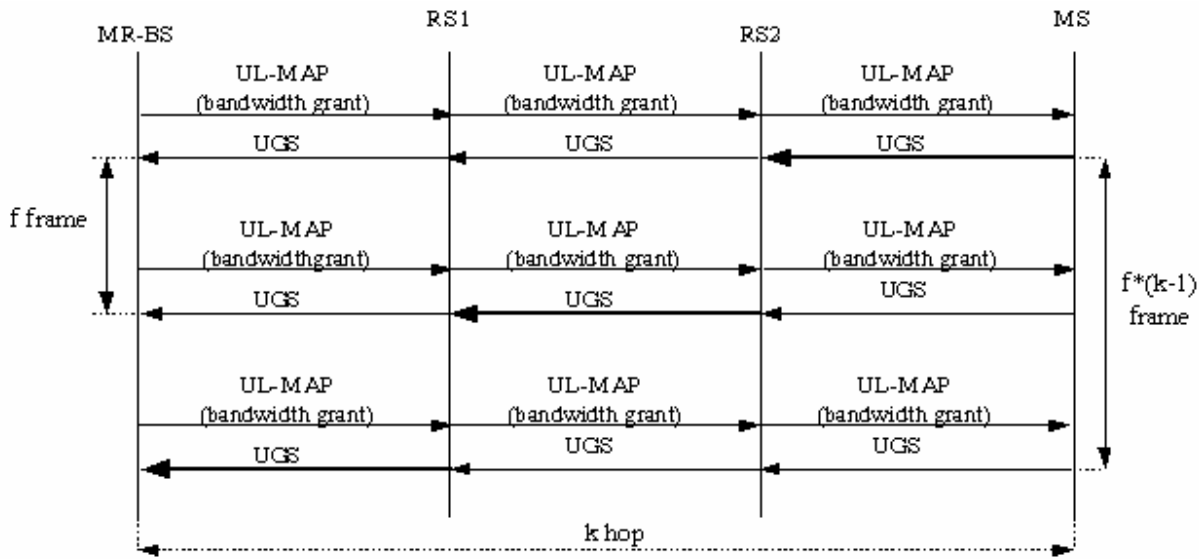

Figure 1- an example of UGS transfer in k-hop link

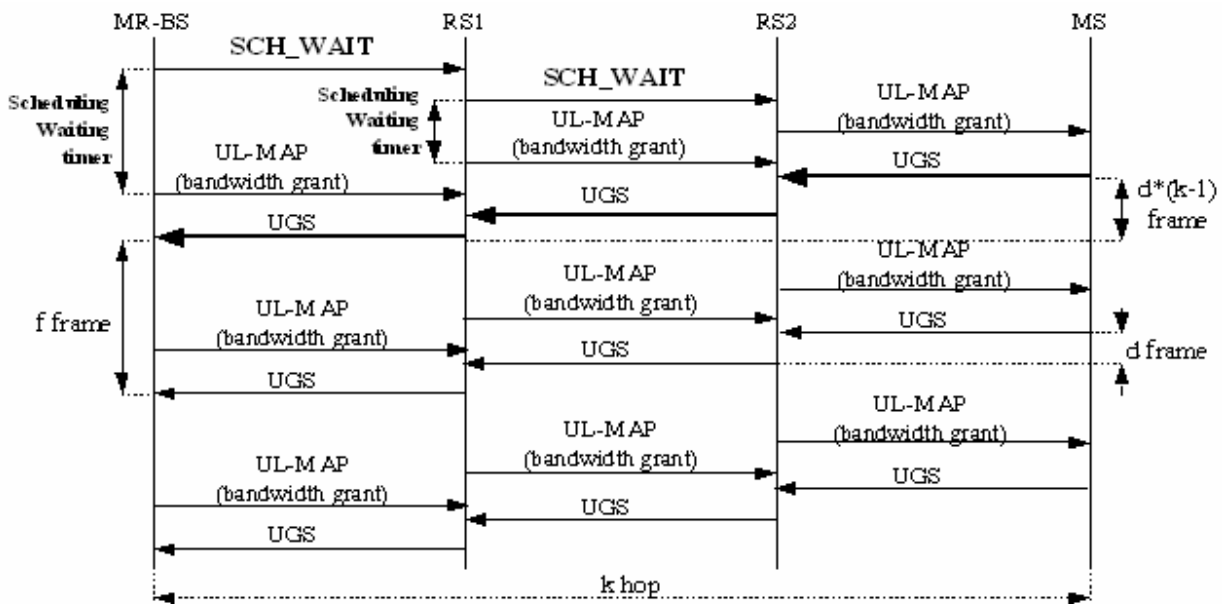

Figure 2- optimized UGS transfer in k-hop link

To prevent the long delay time incurred by multi-hop link, the MMR-BS should arrange RSs to grant bandwidth in order. When  $f > 1$ , for the first time granting, RS being MS's anchor station grants the bandwidth first, then the RS the second near to MS and so on. At last, the MMR-BS grants the bandwidth. In this order, the delay time can be decreased to only  $k$  frame at least.

Therefore, it is defined a new message-SCH\_WAIT message to notify RSs along the link between the MMR-BS and the MS when to grant bandwidth for the first time.

**Another example:**

To create rtPS service flow, the RS being the MS’s anchor station should supply unicast request opportunities to the MS on the real-time periodic basis. To accelerate setting up link for rtPS service flow, the first PDU of rtPS service flow shall be transferred on bandwidth requested through unicast polling opportunity. Furthermore, to ensure the QoS of rtPS service more sufficiently, it is proposed that intermediate RSs and MMR-BS may supply unicast request opportunities to the next hop node on real-time periodic basis after the first packet transfer.

To save the latency of data transfer on the k-hop link, SCH\_WAIT message is also be used to notify RSs when to polling the next hop node (for the first time, when polling is periodic).

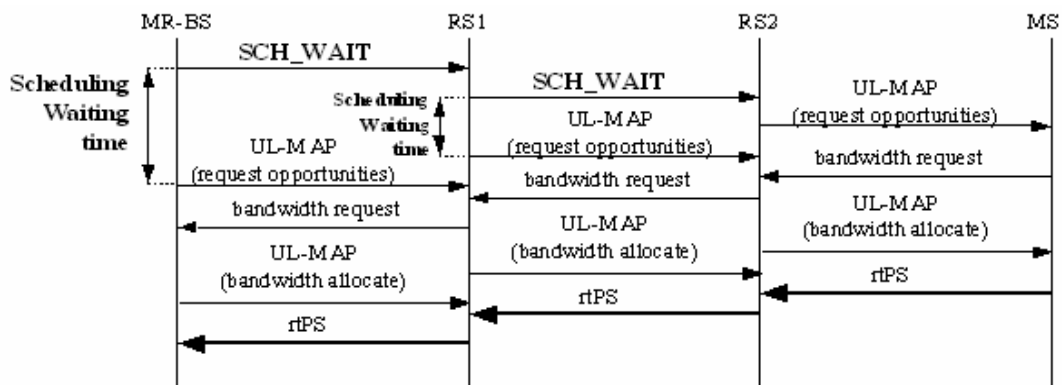

Figure 3- optimized rtPS transfer in k-hop link

When the MMR-BS decides to set up link for a special service flow, it sends the SCH\_WAIT message to the RSs along the k-hop link firstly. In SCH-WAIT message, it includes the Scheduling Waiting time for the RSs except which is MS’s anchor station. When SCH-WAIT message arrives at MS’s anchor station, it is only notify this RS to grant bandwidth or pooling immediately.

Scheduling Waiting time should be set not so large as to delay the data/message transfer , and not so short as RS having no data/message to send when RS is granted bandwidth or RS having not gotten how much bandwidth needed when RS is polled. Scheduling Waiting time in a RS n hop away from the MS should be subject to the following:

---Minimum value: Scheduling Waiting time  $\geq (n-1)*2$  (frame)

**Proposed text**

6.3.5 Scheduling services

6.3.5.2.1 UGS

*Insert the follow at the end of this clause:*

In the 802.16j system, to create a UGS service flow in a k-hop link, the MMR- BS and RSs along the link grant fixed size bandwidth to its next hop node on the real-time periodic basis.

By specifying a UGS service with its associated QoS parameters and knowing the routing information of the link on which the UGS service is transferred, the MMR-BS scheduler can arrange the granting sequence between the MMR-BS and RSs. Before the MMR-BS and RSs grant bandwidth to their next hop node, the MMR-BS sends SCH-WAIT message to RSs along the link. When the RSs except MS's anchor station receive the message, they set their each scheduling\_waiting-timer. As the timers expire, they can grant the bandwidth to their next hop node for the first time. When the MS's anchor station gets the SCH-WAIT message, it grants the bandwidth immediately.

#### 6.3.5.2.1 rtPS

*Insert the follow at the end of this clause:*

In the 802.16j system, to create a rtPS service flow in a k-hop link, the RS being the MS's anchor station should supply unicast request opportunities to the MS on the real-time periodic basis. To accelerate setting up link for rtPS service flow, the first packet shall be transferred on bandwidth requested though unicast polling opportunity. As for the following packet, intermediate RSs, between MMR-BS and RS being MS's anchor station, and the MMR-BS may supply unicast request opportunities to the next hop node on real-time periodic basis.

The MMR-BS scheduler can arrange the polling sequence between the MMR-BS and RSs. Before the MMR-BS and RSs poll their next hop node, the MMR-BS sends SCH-WAIT message to RSs along the link. When the RSs except MS's anchor station receive the message, they set their each scheduling\_waiting-timer. As the timers expire, they can poll their next hop node for the first time. When the MS's anchor station gets the SCH-WAIT message, it polls the MS immediately.

#### 6.3.5.2.2.1 Extended rtPS

*Insert the follow at the end of this clause:*

In the 802.16j system, to create an extended rtPS service flow in a k-hop link, the MMR-BS and RSs along the link grant variable size bandwidth to its next hop node on the real-time periodic basis.

The MMR-BS scheduler can arrange the granting sequence between the MMR-BS and RSs. Before the MMR-BS and RSs grant bandwidth to their next hop node, the MMR-BS sends SCH-WAIT message to RSs along the link. When the RSs except MS's anchor station receive the message, they set their each scheduling\_waiting-timer. As the timers expire, they can grant the bandwidth to their next hop node for the first time. When the MS's anchor station gets the SCH-WAIT message, it grants the bandwidth immediately.

In case that no unicast bandwidth request opportunities are available, the MS may use contention request opportunities for that connection, or send the CQICH codeword to inform the MMR-BS of its having the data to send. If the MMR-BS receives the CQICH codeword, the MMR-BS shall start allocating the UL grant corresponding to the current Maximum Sustained Traffic Rate value by sending a new SCH-WAIT message.

*Insert new subclause 6.3.7.6.1:*

#### 6.3.7.6.1. Distributed Scheduling

In 802.16j system, distributed Scheduling is an optional scheduling mechanism. To using distributed Scheduling, a RS should create his own DL/UL\_MAP, DCD/UCD.

#### 6.3.7.6.1.1 Requests

In 802.16j system, a RS may request the bandwidth to send its message originated by itself and message/data originated by MS. A Request may come as a stand-alone bandwidth request header, a PiggyBack Request or CDMA bandwidth request.

RS's bandwidth request is dressed on connections.

#### 6.3.7.6.1.2 Grants

In the 802.16j system, the bandwidth grant is addressed to the RS/MS Basic CID.

When k links in a k-hop link need to be granted bandwidth to transfer a service flow, granting sequence should be arranged by SCH-WAIT message.

#### 6.3.7.6.1.3 Polling

Polling is done on RS/MS basis.

When k links in a k-hop link need to be pooled in order to transfer a service flow, polling sequence should be arranged by SCH-WAIT message.

*Insert new subclause 6.3.2.3.62:*

#### 6.3.2.3.62 SCH-WAIT message

A MMR-BS or RS sends SCH-WAIT message to the RSs to notify them when to allocate bandwidth to the next hop node.

Table 109z-SCH-WAIT message format

Syntax	Size	Notes
SCH-WAIT_Message_format () {	-	-
Management Message Type=66	8bit	-
CID	16bit	Referring to Connection who needs the bandwidth
Num_RS	4bit	Number of RSs along the link except MS's anchor station
for (i=0; i<Num_RS i++){	-	-
RS MAC address	48bit	
Scheduling Waiting time	4bit	How many frames the RS should wait
}	-	-
Padding	Variable	Padding bit to ensure byte aligned
TLV encoded information	4bit	
}	-	-

Scheduling Waiting time: it is the number of frames that MMR-BS suggests a RS waits before Polling or grant for the first time. If the Scheduling Waiting Time is equal to 0, the RS polls or grants in the next frame, which is follow the frame where the SCH-WAIT message is received.

The Scheduling Waiting Time should be set not so large as to delay the data/message transfer , and not so short as RS having no data/message to send when RS is granted bandwidth or RS having not gotten how much bandwidth needed when RS is polled. Scheduling Waiting time in a RS n hop away from the MS should be subject to the following:

---Minimum value: Scheduling Waiting time  $\geq (n-1)*2$  (frame)