

Project	IEEE 802.16 Broadband Wireless Access Working Group < http://ieee802.org/16 >	
Title	MS Network Entry for transparent Relay Station	
Date Submitted	2007-01-18	
Source(s)	Masato Okuda, Yuefeng Zhou Fujitsu Laboratories LTD.	Voice: +81-44-754-2811 okuda@jp.fujitsu.com
	Chie Ming Chou, Tzu-Ming Lin, Wern-Ho Sheen, Fang-Ching Ren, Jen-Shun Yang, I-Kang Fu, Ching-Tang Hsieh Industrial Technology Research Institute (ITRI)/ National Chiao Tung University (NCTU).	chieming@itri.org.tw
	Yu Ge, Chen-Khong Tham, and Peng-Yong Kong Institute for Infocomm Research	Voice: +65 – 6874.1950 Email: geyu@i2r.a-star.edu.sg
	Gang Shen, Zhang -KaiBin Zhang Alcatel Shanghai Bell Co., Ltd.	Voice: 86-21-58541240-8194 Gang.A.Shen@alcatel-sbell.com.cn
	Shashikant Maheshwari, Yousuf Saifullah, Haihong Zheng Nokia	shashikant.maheshwari@nokia.com , Yousuf.saifullah@nokia.com ,
	Yanling Lu, Ting Li Hisilicon Technologies	luyanling@hisilicon.com Voice: 86-10-82829010
	David Comstock, John Lee, Zheng Shang, Jingning Zhu Huawei Technologies	dcomstock@huawei.com Voice: +1 858 735 9382
	Kanchei (Ken) Loa, Yung-Ting Lee, Yi-Hsueh Tsai, Heng-Iang Hsu, Chih-Chiang Hsieh, Shiann-Tsong Sheu, Frank C.D. Tsai, Youn-Tai Lee, Hua-Chiang Yin, Institute for Information Industry 8F., No. 218, Sec. 2, Dunhua S. Rd., Taipei City, Taiwan.	Voice: +886-2-2739-9616 loa@iii.org.tw
	Hang Zhang, Peiying Zhu, Mo-Han Fong, Wen Tong, David Steer, Gamini Senarath, Derek Yu, Mark Naden, G.Q. Wang Nortel 3500 Carling Avenue, Ottawa, Ontario K2H 8E9	Voice: +1 613 7631315 WenTong@nortel.com pyzhu@nortel.com
	Eugene Visotsky, Peterson Roger, Philippe Sartori, Mohsin Mollah, Masahito Asa Motorola	eugenev@motorola.com mohsin@motorola.com
	Yuan-Ying (Irene) Hsu Telcordia Applied Research Center Taiwan Co., Taipei, Taiwan	Voice : +886-2-37895177#4558 Fax : +886-2-26552078 yyhsu@tarc-tw.research.telcordia.com
	Aik Chindapol, Jimmy Chui Siemens Corporate Research	Voice: +1 609 734 3364 aik.chindapol@siemens.com
Re:	IEEE802.16j-06/027034: “Call for Technical Proposals regarding IEEE802.16j”	

Abstract	This contribution proposes MS network entry procedures and additional TLVs in transparent Relay Station systems.
Purpose	To propose text to describe MS network entry in non -transparent Relay Station systems
Notice	This document has been prepared to assist IEEE 802.16. It is offered as a basis for discussion and is not binding on the contributing individual(s) or organization(s). The material in this document is subject to change in form and content after further study. The contributor(s) reserve(s) the right to add, amend or withdraw material contained herein.
Release	The contributor grants a free, irrevocable license to the IEEE to incorporate material contained in this contribution, and any modifications thereof, in the creation of an IEEE Standards publication; to copyright in the IEEE's name any IEEE Standards publication even though it may include portions of this contribution; and at the IEEE's sole discretion to permit others to reproduce in whole or in part the resulting IEEE Standards publication. The contributor also acknowledges and accepts that this contribution may be made public by IEEE 802.16.
Patent Policy and Procedures	The contributor is familiar with the IEEE 802.16 Patent Policy and Procedures < http://ieee802.org/16/ipr/patents/policy.html >, including the statement "IEEE standards may include the known use of patent(s), including patent applications, provided the IEEE receives assurance from the patent holder or applicant with respect to patents essential for compliance with both mandatory and optional portions of the standard." Early disclosure to the Working Group of patent information that might be relevant to the standard is essential to reduce the possibility for delays in the development process and increase the likelihood that the draft publication will be approved for publication. Please notify the Chair < mailto:chair@wirelessman.org > as early as possible, in written or electronic form, if patented technology (or technology under patent application) might be incorporated into a draft standard being developed within the IEEE 802.16 Working Group. The Chair will disclose this notification via the IEEE 802.16 web site < http://ieee802.org/16/ipr/patents/notices >.

MS Network Entry for transparent Relay Station

Masato Okuda, Yuefeng Zhou

Chie Ming Chou, Tzu-Ming Lin, Wern-Ho Sheen, Fang-Ching Ren,

Jen-Shun Yang, I-Kang Fu, Ching-Tang Hsieh

Yu Ge, Chen-Khong Tham, and Peng-Yong Kong

Gang Shen, ~~Zhang KaiBin~~, Zhang

Yanling Lu, Ting Li, David Comstock, John Lee, Zheng Shang, Jingning Zhu

Kanchei (Ken) Loa, Yung-Ting Lee, Yi-Hsueh Tsai, Heng-Iang Hsu, Chih-Chiang Hsieh,

Shiann-Tsong Sheu, Frank C.D. Tsai, Youn-Tai Lee, Hua-Chiang Yin,

Hang Zhang, Peiyong Zhu, Mo-Han Fong, Wen Tong, David Steer, Gamini Senarath, Derek Yu,

Mark Naden, G.Q. Wang

Eugene Visotsky, Peterson Roger, Philippe Sartori, Mohsin Mollah, Masahito Asa

Yuan-Ying (Irene) Hsu

Aik Chindapol, Jimmy Chui

Introduction

This contribution proposes MS network entry procedure and additional TLVs in transparent RS systems.

The transparent RS does not transmit preamble and MAPs. A MS synchronizes with the MR-BS and receives MAPs from it, while downstream/upstream traffic is relayed. Therefore, it does not recognize existence of the RS even though it communicates with the MR-BS via the transparent RS. In the relay network, MS shall follow the legacy network entry and initialization procedures for backward compatibility. RS is involved in for message detection and relaying. In MS initialization, MS may be located in the overlapped area covered by several RSs and MR-BS. MR-BS shall make a determination as to appropriate access station for the MS to achieve an optimal MS-BS path. In other words, MR-BS should decide whether RS or which RS is required for a specified MS. For the purpose of the optimal path selection, MS-RS link quality shall be measured and reported to MR-BS.

Figure A-1 illustrates an example of transparent RS system.

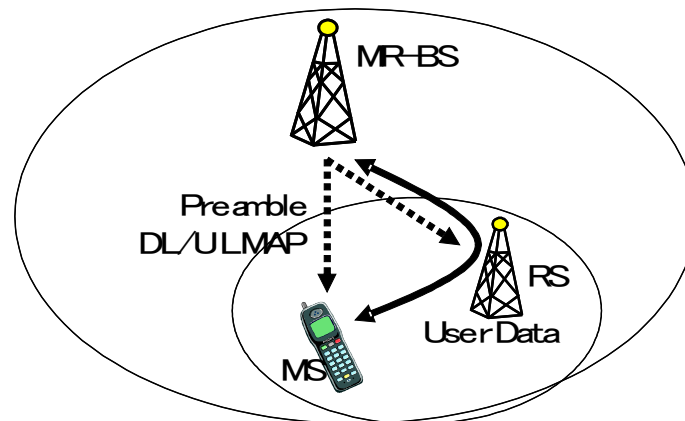

Figure A-1 Example of transparent RS system

This contribution describes detail messages sequence and RS and MR-BS behavior during ranging process and additional new TLVs, so that the MR-BS can decide the appropriate path (direct or relay path) for each MS.

Specific Text Changes

Insert the new subclause 6.3.9.16.1 (in “Support for network entry and initialization in relay mode”):

6.3.9.16.1 MS network entry procedures in transparent RS systems

In network entry procedure in transparent RS systems, MS scans for downlink channel and establish synchronization with the MR-BS, then obtains transmit parameters from UCD message as described in 6.3.9.1 through 6.3.9.4.

The initial ranging process shall begin by sending initial-ranging CDMA codes on the UL allocation dedicated for that purpose (for more details see 6.3.10.3). The RS shall monitor ranging channel assigned by the MR-BS.

The code may be received by the MR-BS and some RSs near the MS. RSs receiving the code with sufficient signal quality shall transmit a RNG-REQ to the MR-BS with the RS basic CID. The RNG-REQ message contains ranging status, code attributes and adjustment information such as frequency, timing and transmission power. When a RS receives multiple codes in a frame, the RS sends a RNG-REQ message which contains information of multiple codes which are received with sufficient signal quality.

When the MR-BS receives ranging code, it shall wait for RNG-REQ with the same ranging code from its subordinate RSs for T48 timer. Once T48 timer expired, the MR-BS compares measured signal information at each station to decide the most appropriate path to communicate with the code originating MS, according to channel measurement information. Algorithms to select a path are out of scope of this document.

When the ranging status at the selected path is continue, the MR-BS transmits a RNG-RSP to the MS directly with initial ranging CID. The RNG-RSP shall contain adjustment information measured at the RS on the selected path. If the ranging code has been successfully received at the access RS on the selected path ~~and the MR-BS decides to apply uplink and downlink relaying to the MS, the MR-BS transmits a RNG-RSP to the RS with the RS’s basic CID in order to notify the RS to receives and relays a RNG-REQ message transmitted on a burst specified with CDMA Allocation-IE in UL-MAP after decoding the UL-MAP or optionally R-MAP in the same frame. The MAP messages and IEs are defined in 8.4.5. If the direct communication is selected, the MR-BS follows sequence described in 6.3.10.3.~~

Once the RS receives a RNG-REQ containing ~~MS’s~~ MAC address with initial ranging CID, it forwards the message to the MR-BS with the RS basic CID, so that the MR-BS can identify the RS with which the MS connects.

Receiving the RNG-REQ, the MR-BS assigns basic and primary CIDs to the MS and sends ~~back~~ the RNG-RSP, which contains just assigned ~~containing the management messages~~ CIDs of MS, to the MS directly with the RS basic initial ranging CID. ~~The RS relays it to the MS with changing the CID to the initial ranging CID.~~

After assigning the basic and primary CID to the MS, the MS and the MR-BS continue network entry process as described in the 6.3.9.7 through 6.3.9.13 using the MS’s management CIDs. The RS on the selected path shall relay messages between them. The RS may monitor management messages and derive some information for some purpose which is out of scope of this document.

The message sequences chart (Table xxx) and flow charts (Figure xxx, Figure xxx, and Figure xxx) on the following pages define the ranging and adjustment process that shall be followed by compliant RSs and MMR-BSs. For CDMA ranging process between RS and MS, these details can be found in 6.3.10.3.

~~Optionally, the MS network entry process in transparent RS system will proceed with relaying of messages and data on uplink only, while relying on the direct MR-BS to MS transmissions on the downlink. -The message sequence chart for this process is provided in Table yyyy the same as the one of DL/UL relaying~~

described in Table xxx.

~~When the MR-BS decides to apply uplink only relaying to the MS, it send a duplicate RNG-RSP to the RS as well as a RNG-RSP to the MS. The duplicate RNG-RSP shall be transmitted with the RS's basic CID and contain the Ranging Method TLV in addition to information in the RNG-RSP sent to the MS in order to notify the RS of relaying uplink traffic from the MS. The duplicate RNG-RSP is never relayed to the MS.~~

Table xxx Ranging and automatic adjustments procedure in MR mode

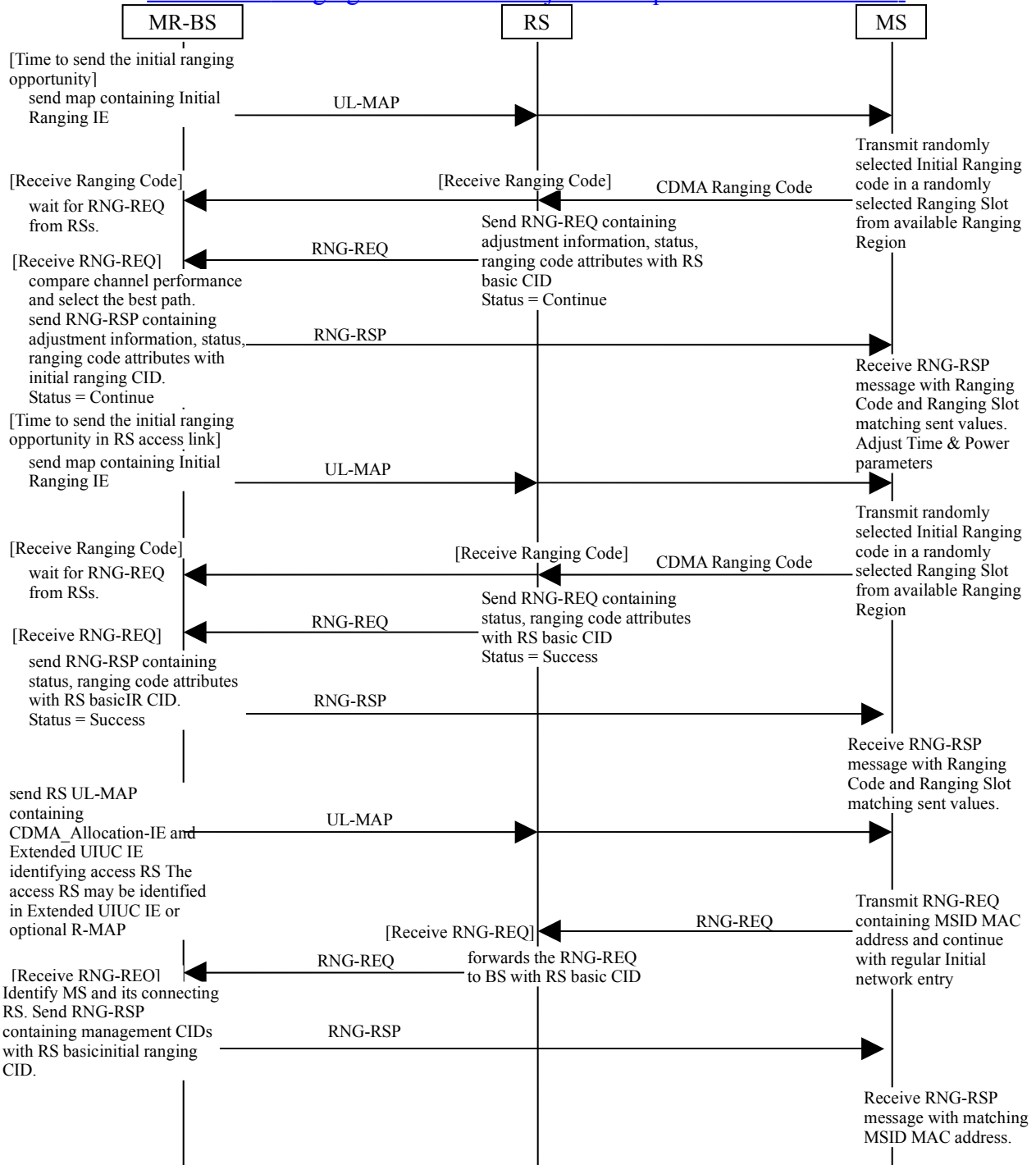
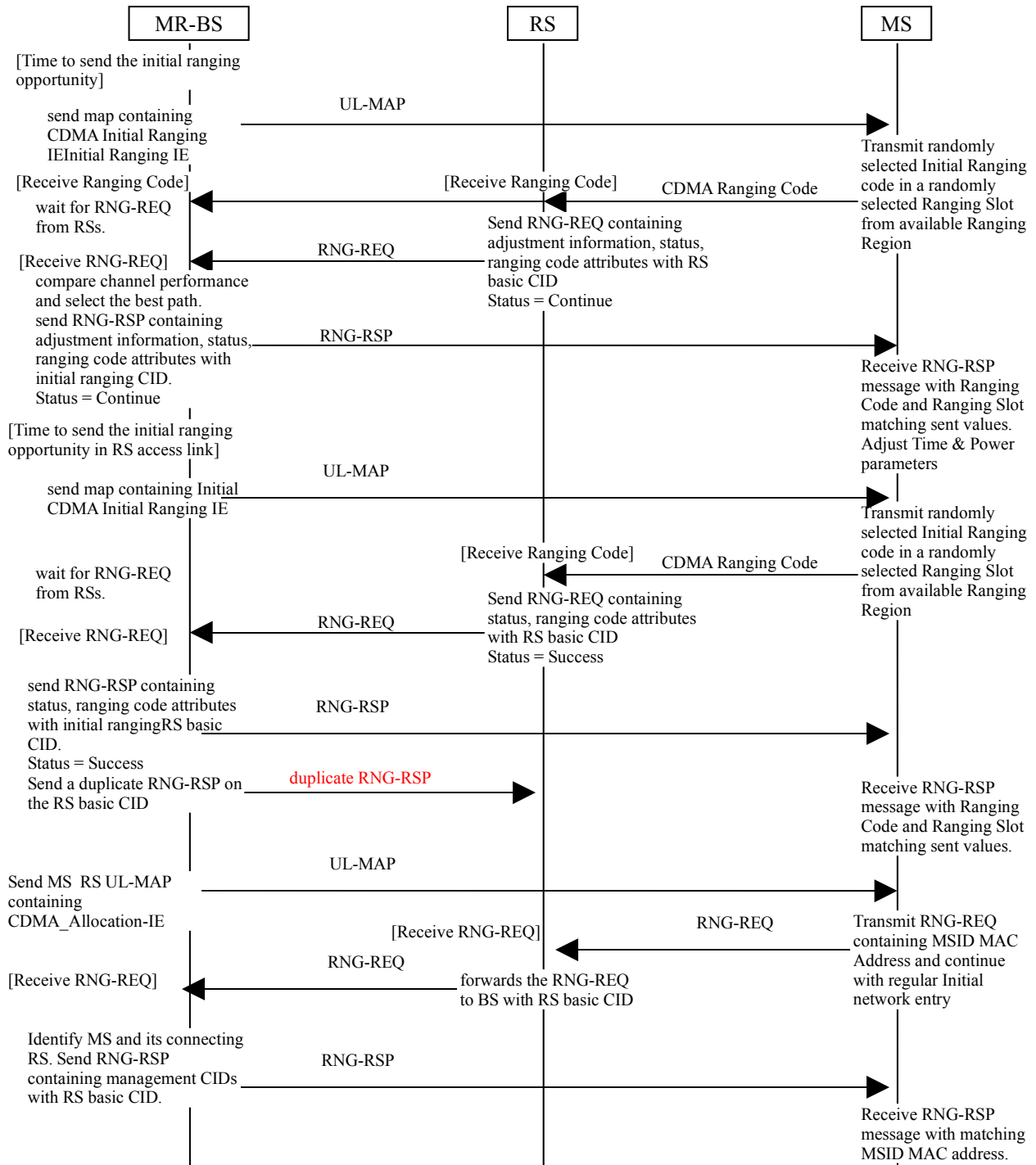

Table yyy Ranging and automatic adjustments procedure in MR mode with optional UL only relaying



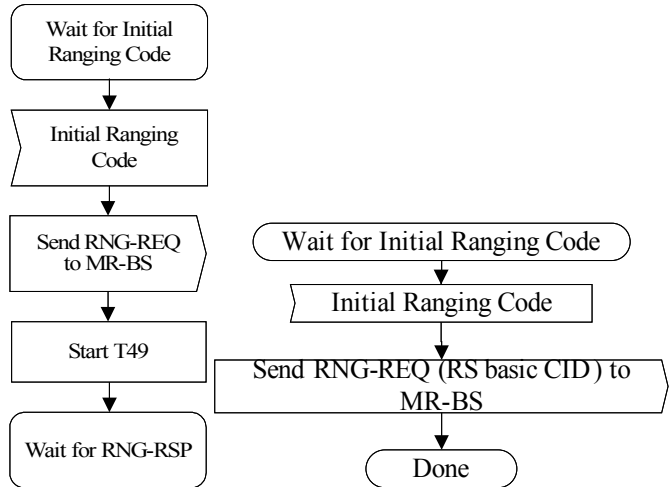
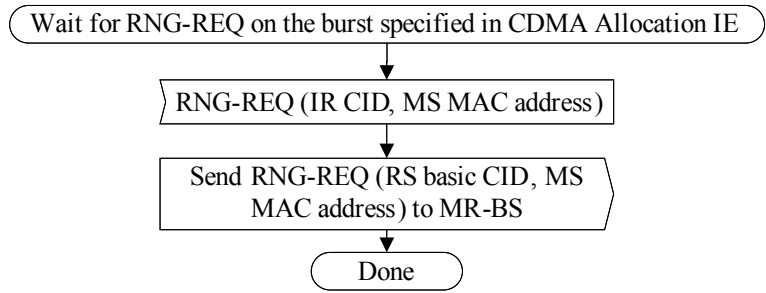

Figure xxx MS CDMA initial Ranging -- Access Transparent RS



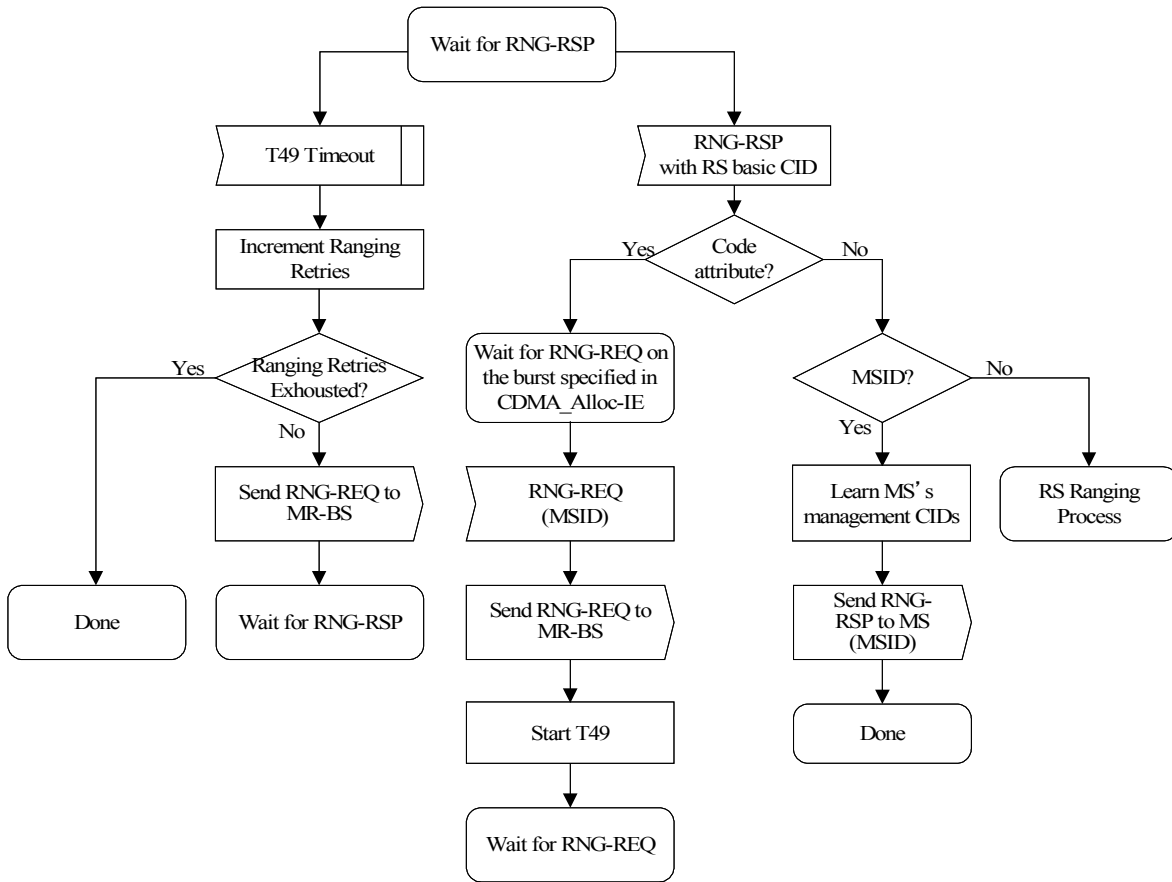

Figure xxx MS initial Ranging -- Access Transparent RS

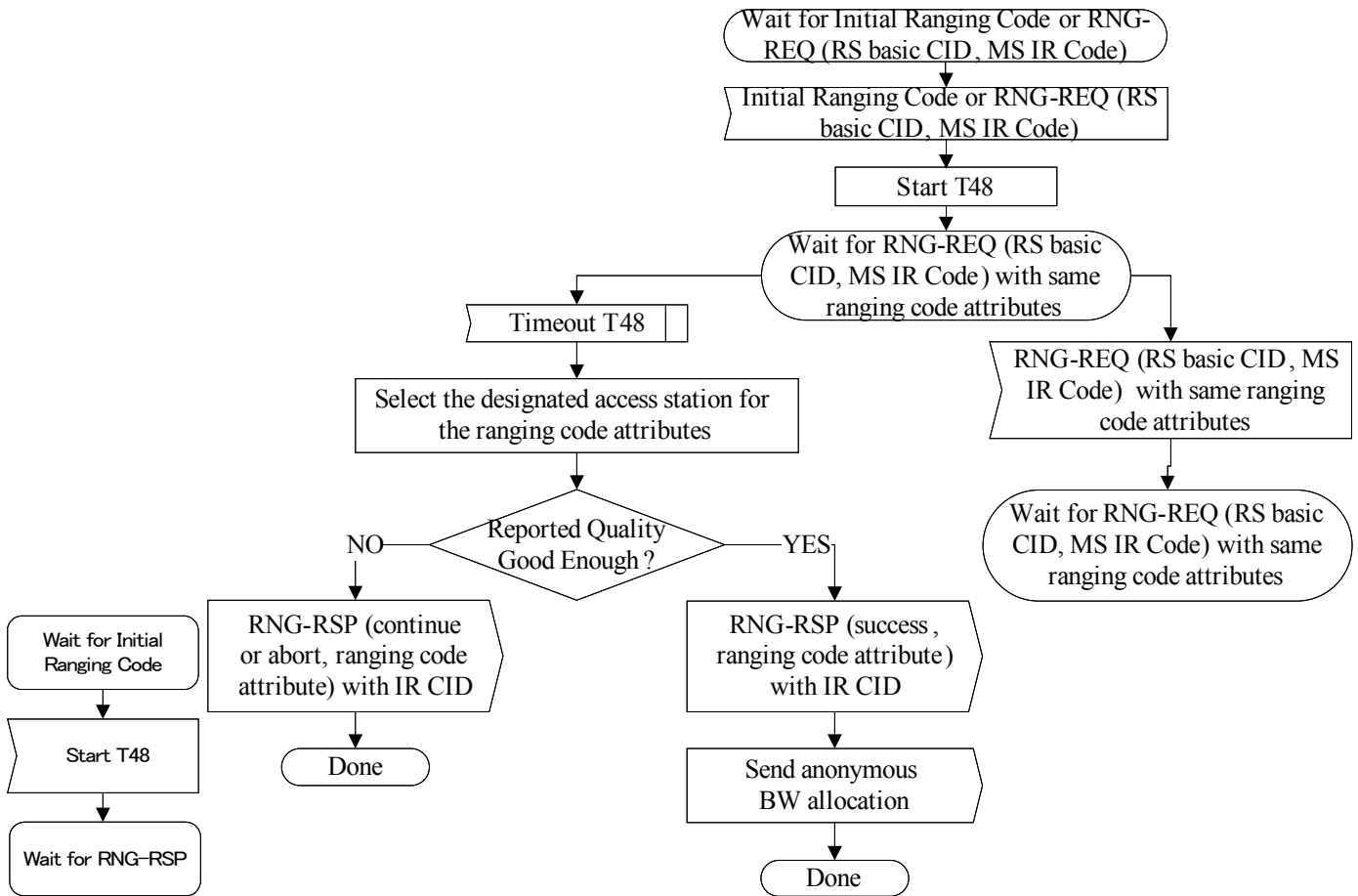
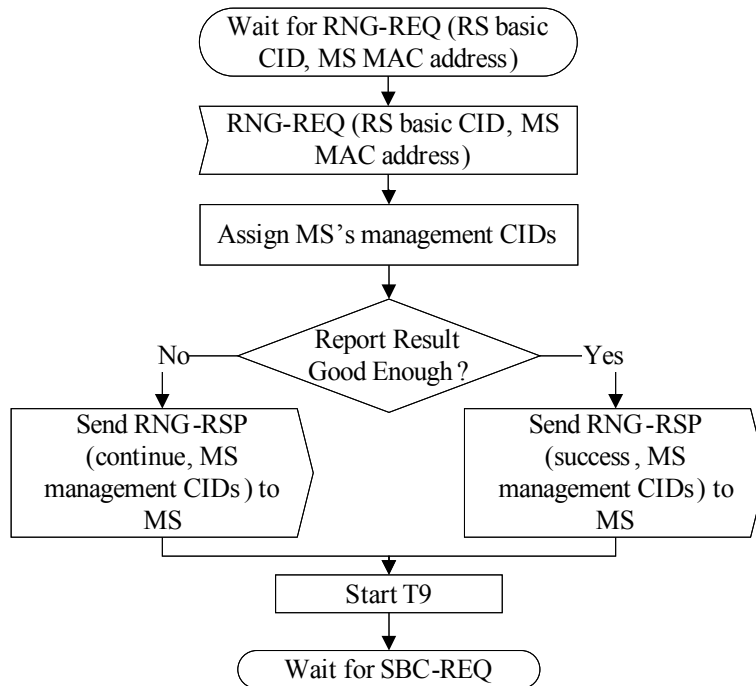

Figure xxx MS CDMA initial-Initial Ranging with Transparent RS – MR-BS



Note: T9 is the timer between the MR-BS sending a n RNG-RSP to an MS and receiving a n SBC-REQ from the same MS

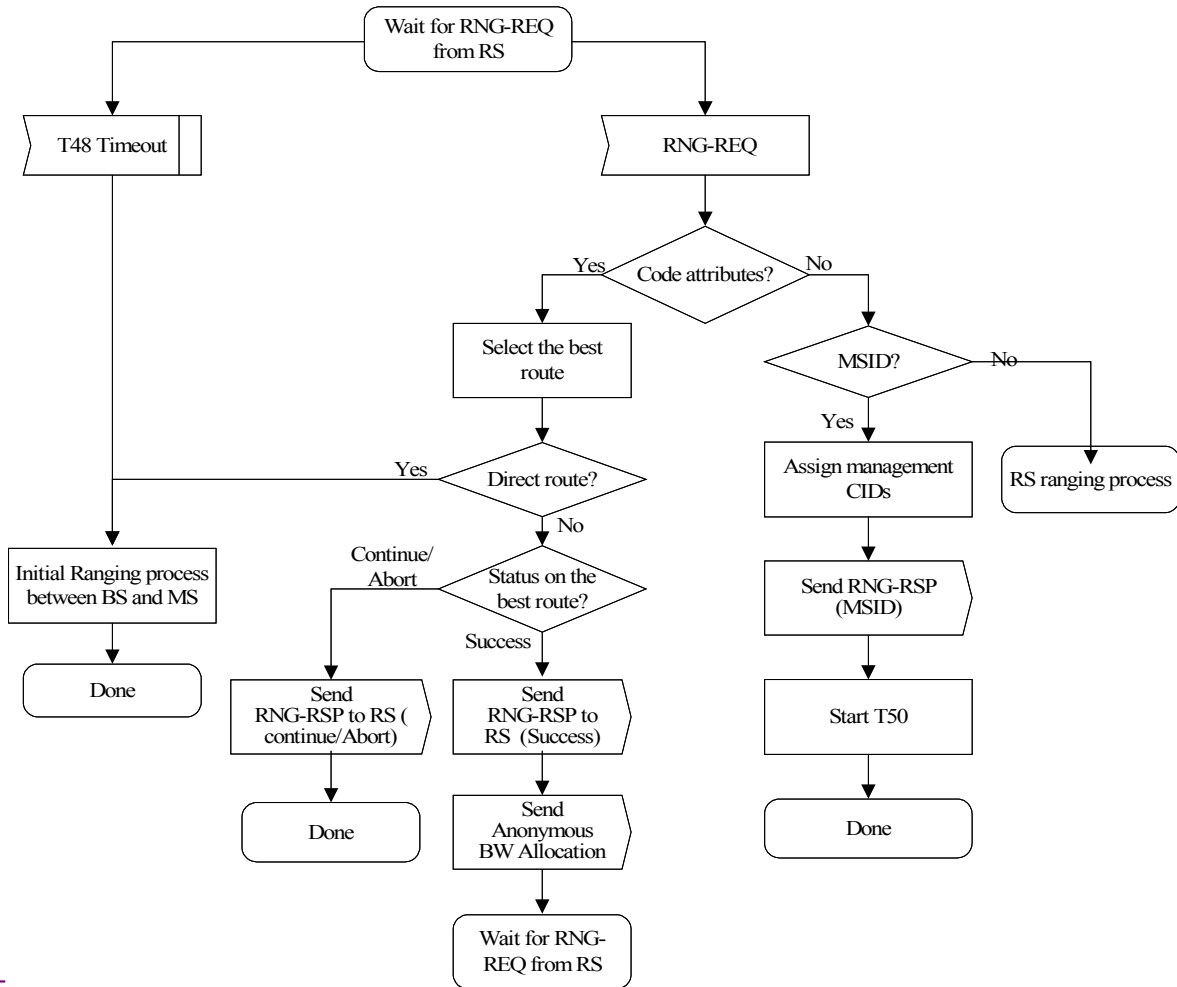

Figure xxx MS initial-Initial Ranging with Transparent RS– MR-BS

Insert the following rows into Table 342 at 10.1 Global Values:

Table 342—Parameters and constants

System	Name	Time reference	Minimum value	Default value	Maximum value
MR-BS	T48	Wait for RNG-REQ from the subordinate RS	tbd	tbd	
RS	T49	Ranging-Response reception timeout following the transmission of a Ranging Request to MR-BS		tbd	tbd
MR-BS	T50	Registration Timeout, the time allowed between the MR-BS sending a RNG-RSP (success) to an SS via RS, and receiving a SBC-REQ from that same SS via RS	tbd	tbd	

Insert the following rows into Table 364 at 11.5 RNG-REQ TLV:

Table 364—RNG-REQ message encodings

Name	Type (1 byte)	Length	Value (variable-length)	PHY Scope
Received Ranging Codes	TBA	Variable	Received Ranging Codes is a compound TLV value that indicates received code information.	OFDMA
Timing Adjust	TBA.1	4	Tx timing offset adjustment (signed 32-bit). The amount of time required to adjust SS transmission so the bursts will arrive at the expected time instance at the BS. Units are PHY specific (see 10.3).	OFDMA
Power Level Adjust	TBA.2	1	Tx Power offset adjustment (signed 8-bit, 0.25 dB units) Specifies the relative change in transmission power level that the SS is to make in order that transmissions arrive at the BS at the desired power. When subchannelization is employed, the subscriber shall interpret the power offset adjustment as a required change to the transmitted power density.	OFDMA
Offset Frequency Adjust	TBA.3	4	Tx frequency offset adjustment (signed 32-bit, Hz units). Specifies the relative change in transmission frequency that the SS is to make in order to better match the BS. (This is fine-frequency adjustment within a channel, not reassignment to a different channel.)	OFDMA
Ranging Status	TBA.4	1	Used to indicate whether uplink messages are received within acceptable limits by BS. 1 = continue, 2 = abort, 3 = success	OFDMA
Ranging code attributes	TBA.5	4	Bits 31:22 – Used to indicate the OFDM time symbol reference that was used to transmit the ranging code. Bits 21:16 – Used to indicate the OFDMA subchannel reference that was used to transmit the ranging code. Bits 15:8 – Used to indicate the ranging code index that was sent by the SS. Bits 7:0 – The 8 least significant bits of the frame number of the OFDMA frame where the SS sent the ranging code.	OFDMA
Channel Measurement Information	TBA.6	TBA	TBD	

Insert the following rows into Table 367 at 11.6 RNG-RSP TLV:

Table 367—RNG-RSP message encodings

Name	Type (1-byte)	Length h	Value (variable-length)	PHY Scope
Relaying Method	TBA	1	0: Downlink and Uplink relaying (default) 1: Uplink only relaying 2-7: reserved	OFDMA

References

- [1] M.Okuda, "relaying method proposal for 802.16j", IEEE C802.16j-06_132, IEEE 802.16 meeting #46, Dallas, November 2006.
- [2] M.Okuda, et. al, "MS network entry for non-transparent Relay Station with centralized scheduling", IEEE C802.16j-07_008, IEEE 802.16 meeting #47, London, January 2007.
- [3] M.Okuda, et. al, "MS network entry for non-transparent Relay Station with distributed scheduling", IEEE C802.16j-07_024, IEEE 802.16 meeting #47, London, January 2007.