

Project	IEEE 802.16 Broadband Wireless Access Working Group < http://ieee802.org/16 >	
Title	In-band Transparent Relay Frame Structure	
Date Submitted	2006-01-08	
Source(s)	<p>Kanchei (Ken) Loa, Yi-Hsueh Tsai, Chih-Chiang Hsieh, Yung-Ting Lee, Hua-Chiang Yin, Shiann-Tsong Sheu, Frank C.D. Tsai, Youn-Tai Lee, Heng- Iang Hsu Institute for Information Industry 8F., No. 218, Sec. 2, Dunhua S. Rd., Taipei City, Taiwan.</p> <p>Hang Zhang, Peiying Zhu, Mo-Han Fong, Wen Tong, David Steer, Gamini Senarath, Derek Yu, Mark Naden, G.Q. Wang</p> <p>Nortel 3500 Carling Avenue Ottawa, Ontario K2H 8E9</p> <p>[add co-authors here]</p>	<p>Voice: +886-2-2739-9616 loa@iii.org.tw</p> <p>Voice: +1 613 7631315 WenTong@nortel.com pyzhu@nortel.com</p>
Re:	IEEE 802.16j-06/034: "Call for Technical Proposals regarding IEEE Project P802.16j"	
Abstract	This contribution proposes in-band transparent relay frame structure	
Purpose	Text proposal for 802.16j Baseline Document	
Notice	This document has been prepared to assist IEEE 802.16. It is offered as a basis for discussion and is not binding on the contributing individual(s) or organization(s). The material in this document is subject to change in form and content after further study. The contributor(s) reserve(s) the right to add, amend or withdraw material contained herein.	
Release	The contributor grants a free, irrevocable license to the IEEE to incorporate material contained in this contribution, and any modifications thereof, in the creation of an IEEE Standards publication; to copyright in the IEEE's name any IEEE Standards publication even though it may include portions of this contribution; and at the IEEE's sole discretion to permit others to reproduce in whole or in part the resulting IEEE Standards publication. The contributor also acknowledges and accepts that this contribution may be made public by IEEE 802.16.	
Patent Policy and Procedures	The contributor is familiar with the IEEE 802.16 Patent Policy and Procedures < http://ieee802.org/16/ipr/patents/policy.html >, including the statement "IEEE standards may include the known use of patent(s), including patent applications, provided the IEEE receives assurance from the patent holder or applicant with respect to patents essential for compliance with both mandatory and optional portions of the standard." Early disclosure to the Working Group of patent information that might be relevant to the standard is essential to reduce the	

possibility for delays in the development process and increase the likelihood that the draft publication will be approved for publication. Please notify the Chair <mailto:chair@wirelessman.org> as early as possible, in written or electronic form, if patented technology (or technology under patent application) might be incorporated into a draft standard being developed within the IEEE 802.16 Working Group. The Chair will disclose this notification via the IEEE 802.16 web site <<http://ieee802.org/16/ipr/patents/notices>>.

In-band Transparent Relay Frame Structure

Introduction

In IEEE 80216j-06/026r1, frame structures for the MR-BS and non-transparent RS are defined to enable backward compatibility and efficient R-link operation. This contribution proposes a frame structure to enable relaying operations in transparent RS systems. The contribution covers a frame structure for both the Relay and the Access links. This proposal is intended for in-band relay operation with transparent RS (a RS that does not transmit a preamble at the beginning of the DL subframe).

Proposed Frame Structure

The proposed frame structure to enable relaying is illustrated in Figure 1. Based on Figure 1a and 1b, the basic relay frame structure is composed of:

A DL subframe and a UL sub-frame like in the 802.16e case

The DL sub-frame is composed of a DL access zone followed by a cooperative transmit diversity/silent area.

The DL access zone is dedicated to the BS → MS or BS → transparent RS related traffic and transparent RS → MS or transparent RS → child transparent RS related traffic.

Between the DL sub-frame and the UL sub-frame a TTG is placed

The UL sub-frame is composed of a UL access zone followed by a UL relay zone. Between the UL access zone and the related UL relay zone a Relay RTG (RRTG) is placed.

The UL access zone is dedicated to the MS → BS or MS → transparent RS related traffic. The UL relay zone is dedicated to the transparent RS → BS or transparent RS → parent transparent RS related traffic.

The DL access zone for BS is started by a preamble as specified by the 802.16e-2005 standard. The preamble is followed by the Frame Control Header (including the DLFP), DL MAP and UL MAP.

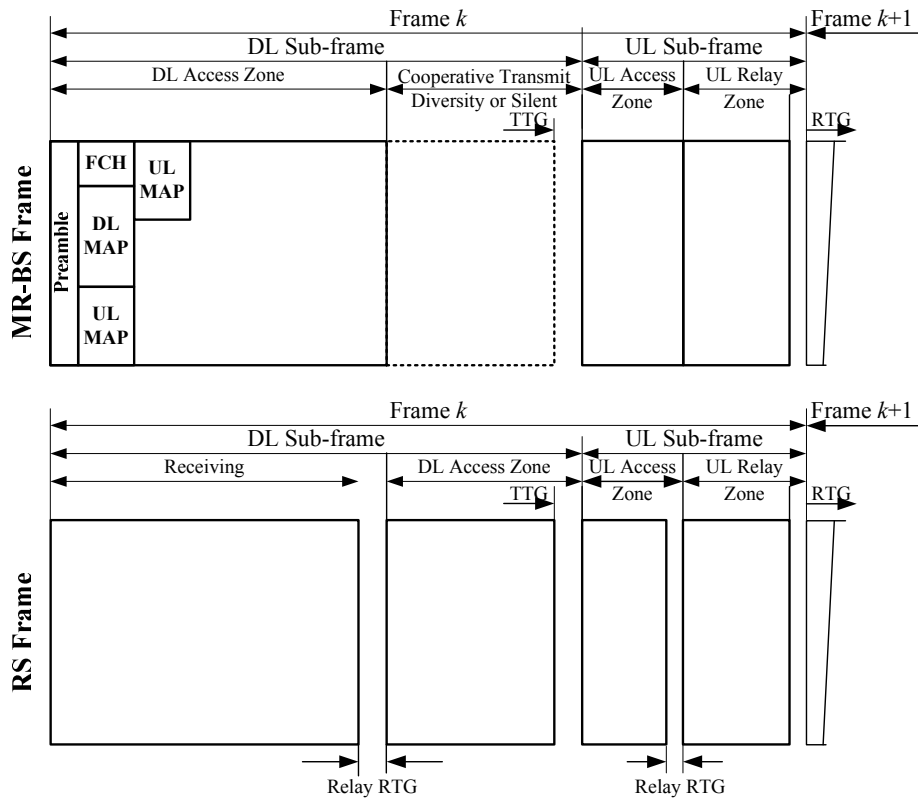

Figure 1a. Example of minimum configuration for transparent relay frame structure.

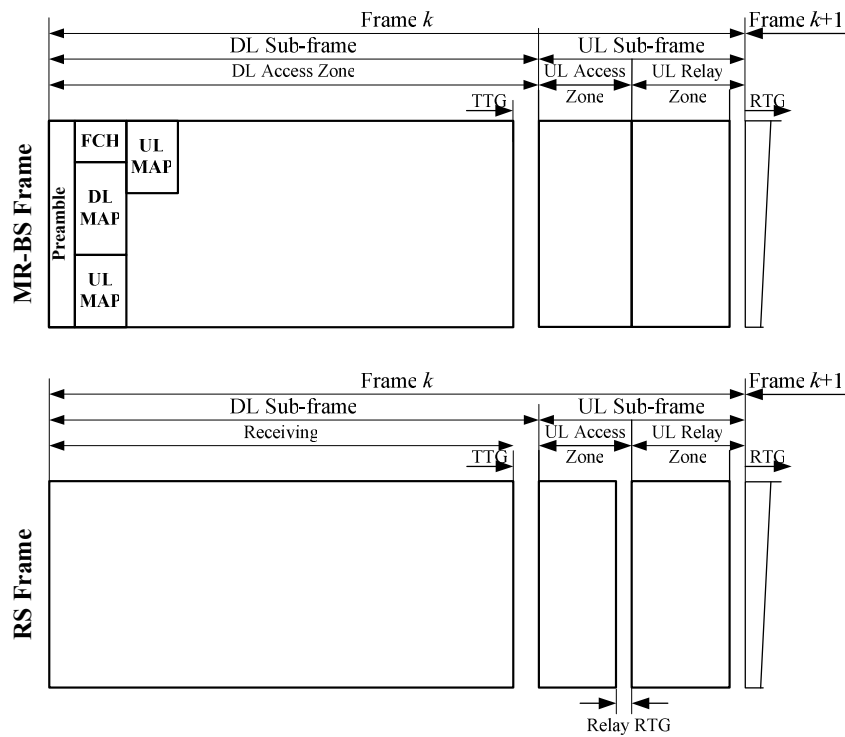

Figure 1b. Example of minimum configuration for upstream-only transparent relay frame structure.

At initialization, the RS performs an initial network entry with the MR-BS in the same way as the MS does, the RS detects a preamble in the MR-BS frame and it establishes the synchronization with the MR-BS. RS continues with

the remaining initial entry network procedures in the access region of the MR-BS frame. After completion of the initial network entry, RS should transmit traffic to MR-BS in the UL relay region of the MR-BS frame.

Conclusion

This proposal provides a simple extension to the existing frame structure defined in C80216j-06/233r8 that enables support for transparent RS.

Proposed text changes

According to the proposed text in IEEE 80216j-06/026r1, we propose the following text changes.

+++++ start text proposal +++++

[Change the text in section 3 “Definitions” as indicated:]

3.90 DL Access_Zone: A portion of the DL sub-frame in the MR-BS/RS frame used for MR-BS/RS to MS or transparent RS transmission.

[Insert the text in section 3 “Definitions” as indicated:]

3.94 Cooperative Transmit Diversity Zone: A portion of the DL sub-frame in the MR-BS/RS frame used for MR-BS/RS to RS/MS transmissions by utilizing transmit diversity schemes.

3.95 Silent Zone: A portion of the DL sub-frame in the MR-BS/RS frame used for providing reduced interference region for RS to RS/MS transmissions within the coverage area of the MR-BS or the RS.

[Insert the following text at subclause 8.4.4.7.1]

8.4.4.7.1.1 MR-BS frame structure

For the TDD mode, an example of the MR-BS frame structure is shown in Figure xxx.

Each MR-BS frame begins with a preamble followed by an FCH, a DL-MAP and possibly an UL-MAP. The DL sub-frame shall include at least one DL Access Zone and may follow by one zone used for Cooperative Transmit Diversity/Silent. The UL sub-frame may include one or more UL Access Zones and it may include one or more UL Relay Zones. In each frame, the TTG shall be inserted between the DL sub-frame and the UL sub-frame. The RTG shall be inserted at the end of each frame. In the DL Access Zone, the subchannel allocation, the FCH transmission, and the FCH shall be defined as in Section 8.4.4.2.

Other attributes of the MR-BS frame and the RS frame such as transition between modulation and coding, presence of multiple zones, may be the same as those described in 8.4.4.2.

The number, size, and location of the relay zones shall be configurable.

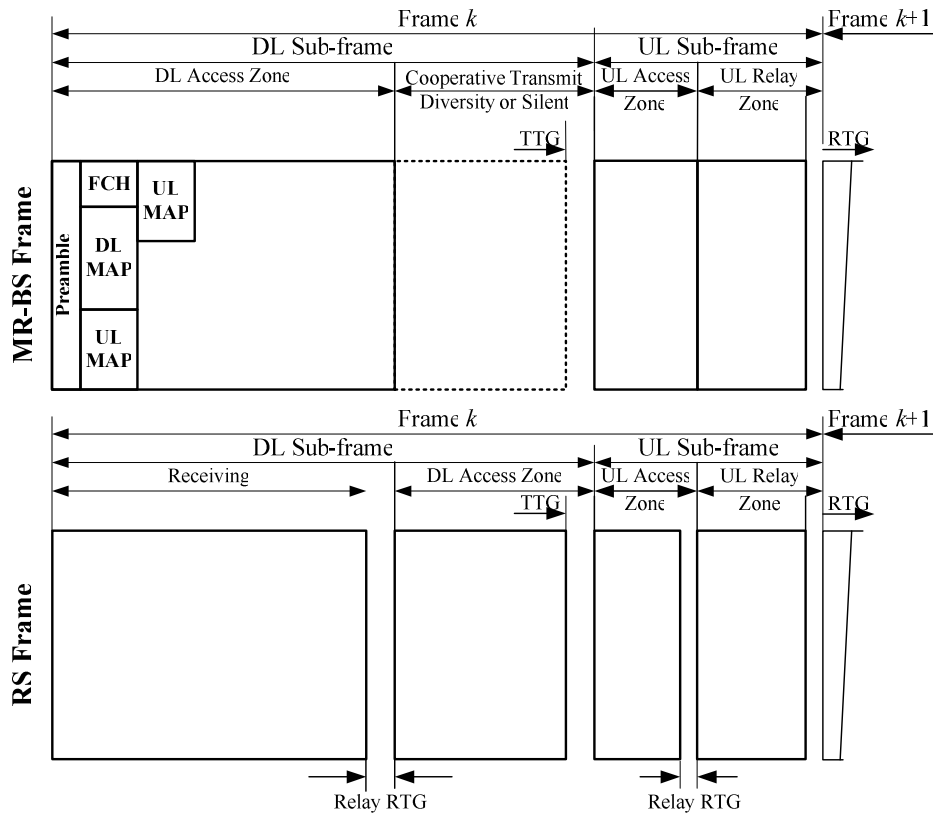

Figure xxx(a) Example of minimum configuration for an in-band transparent relay frame structure

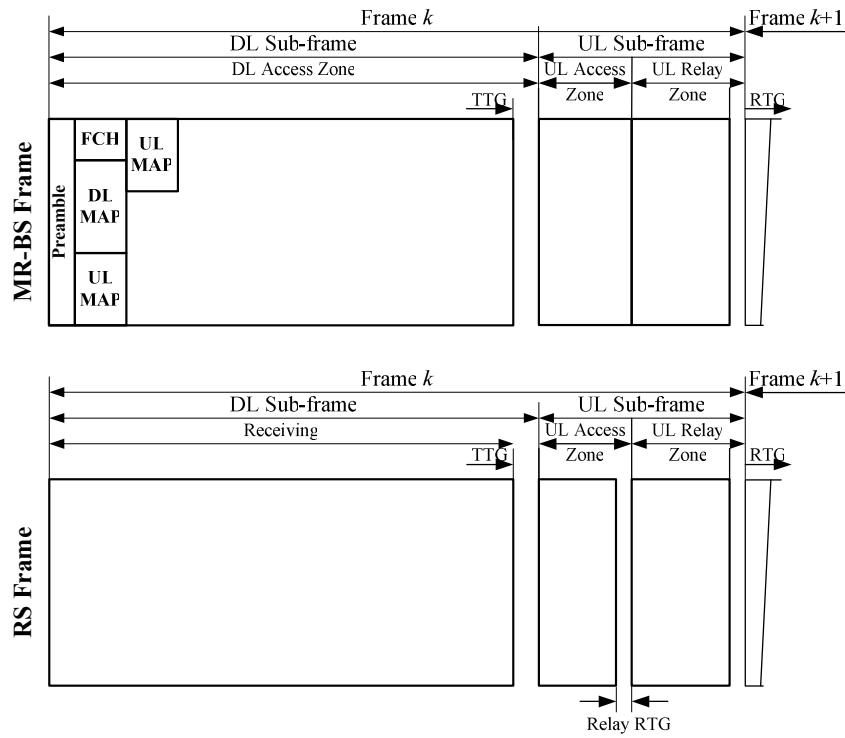

Figure xxx(b) Example of minimum configuration for an in-band upstream-only transparent relay frame structure

8.4.4.7.1.2 Relay frame structure

For the TDD mode, an example of an RS frame structure is shown in Figure xxx.

The Relay Station shall time aligned with its serving MR-BS frame start preamble. The DL sub-frame shall include at least one DL Access Zone and may follow by one zone used for cooperative Transmit Diversity/Silent.

The UL sub-frame may include one or more UL Access Zones and one or more UL Relay Zones. An R-RTG may be placed between a UL Access Zone and a UL Relay Zone.

If the relay station switches from transmission to reception mode, an R-TTG shall be required. If the relay station switches from reception to transmission mode, an R-RTG shall be required. There may be more than one R-TTG and more than one R-RTG inserted in the RS frame. In each frame, the TTG shall be inserted between the DL sub-frame and the UL sub-frame. The RTG shall be inserted at the end of each frame.

After synchronizing with the serving MR-BS preamble, each RS begins to receive the FCH, the DL-MAP, and possibly the UL-MAP from the serving MR-BS. In the DL Access Zone and UL Access Zone, the subchannel allocation shall be as defined in Section 8.4.4.2.

The number, size, and location of the relay zones shall be configurable.

+++++ End of text proposal +++++