

---

**IEEE 802.16 Broadband Wireless Access Working Group <<http://ieee802.org/16>>**

---

Title **On the use of postamble for the relay link**

---

Date Submitted **2007-01-108**

---

Changyoon Oh, Youngbin Chang, Voice: +82-31-279-7529  
 Mihyun Lee, HyoungKyu Lim, Fax: +82-31-279-5130  
 Jaeweon Cho, Panyuh Joo mail to: changyoon.oh@samsung.com  
 Samsung Electronics  
 416, Maetan-3dong, Youngtong-gu,  
 Suwon-si, Gyeonggi-do, Korea

Source(s) Rakesh Taori [rakesh.taori@samsung.com](mailto:rakesh.taori@samsung.com)  
 Samsung Advanced Institute of  
 Technology

[Dorin Viorel](mailto:dviorel@fmci.fujitsu.com) [dviorel@fmci.fujitsu.com](mailto:dviorel@fmci.fujitsu.com)  
[Fujitsu Microelectronics Canada Inc](#)  
[Mike Hart](#)  
[Fujitsu Laboratories Europe](#)

[Jerry Sydir](mailto:jerry.sydir@intel.com) [jerry.sydir@intel.com](mailto:jerry.sydir@intel.com)  
[Intel Corporation](#)

---

Re: Response to call for technical contributions on 80216j-06\_027, "Call for Technical Proposals regarding IEEE Project P802.16j", Sep.15,2006

---

Abstract This contribution proposes the use of postamble for the relay link.

---

Purpose Propose the text regarding the location of amble for the relay link in the multi-hop frame structure.

---

Notice This document has been prepared to assist IEEE 802.16. It is offered as a basis for discussion and is not binding on the contributing individual(s) or organization(s). The material in this document is subject to change in form and content after further study. The contributor(s) reserve(s) the right to add, amend or withdraw material contained herein.

---

Release The contributor grants a free, irrevocable license to the IEEE to incorporate material contained in this contribution, and any modifications thereof, in the creation of an IEEE Standards publication; to copyright in the IEEE's name any IEEE Standards publication even though it may include portions of this contribution; and at the IEEE's sole discretion to permit others to reproduce in whole or in part the resulting IEEE Standards publication. The contributor also acknowledges and accepts that this contribution may be made public by IEEE 802.16.

---

Patent Policy and Procedures The contributor is familiar with the IEEE 802.16 Patent Policy and Procedures <<http://ieee802.org/16/ipr/patents/policy.html>>, including the statement "IEEE standards may include the known use of patent(s), including patent applications, provided the IEEE receives assurance from the patent holder or applicant with respect to patents essential for compliance with both mandatory and optional portions of the standard." Early disclosure to the Working Group of patent information that might be relevant to the standard is essential to reduce the possibility for delays in the development process and increase the likelihood that the draft publication will be approved for publication. Please notify the Chair <<mailto:chair@wirelessman.org>> as early as possible, in written or electronic form, if patented technology (or technology under patent application) might be incorporated into a draft standard being developed within the IEEE 802.16 Working Group. The Chair will disclose this notification via the IEEE 802.16 web site <<http://ieee802.org/16/ipr/patents/notices>>.

---

# On the use of postamble for relay link

Changyoon Oh, Youngbin Chang, Mihyun Lee, HyoungKyu Lim, Jaeweon Cho, Panyuh Joo

*Samsung Electronics*

Rakesh Taori

*Samsung Advanced Institute of Technology*

## 1. Introduction

Figure 1 shows a typical topology that arises in the case of multi-hop relay. To support multi-hop relay, a minimum configuration of the frame structure has been agreed in the task group [1]. The group also agreed that the frame start preamble shall be time aligned throughout the system [2]. Figure 2 shows the minimum configuration of frame structure along with the time aligned preamble as agreed during the November meeting.

In addition to the frame start preamble defined for the access link, an amble is also needed for the relay link in order to enable synchronization as well as to facilitate measurement on the relay link. Furthermore, it is proposed that the amble on the relay link should also be time aligned throughout the network in order to obtain the same benefits as those obtained by the time aligned preamble. For an amble that is time aligned throughout the system in the relay zone, 3 possible cases can arise:

Case 1. Placing the amble at the start of the relay zone.

Case 2. Placing the amble at the end of the relay zone.

Case 3. Placing the amble somewhere in the middle of the relay zone.

Each case is analyzed to assess the benefit in section 2. From the analysis in section 2, it is concluded that the use of postamble is the best among the 3 cases mentioned above. Hence, this contribution proposes the use of postamble for the relay link.

## 2. Analysis of amble location

### 2.1 Case 1: Amble at the start of the relay zone

Figure 3 shows an example of a frame structure wherein the amble is placed at the start of the relay zone and at the end of the relay zone. By noting that each MMR-cell may have a different traffic ratio for the access link and the relay link, we argue that it is beneficial to accommodate flexible ratio of the access zone and the relay zone. However, we can see from Figure 3 that by placing the time aligned amble at the start of the relay zone, we are forced to give up the flexibility in choosing the access zone to relay zone ratio. Therefore, we conclude

that while time aligned amble can be placed at the start of the relay zone, this option results in a loss of flexibility.

### 2.2 Case 2: Amble at the end of the relay zone

By placing the amble at the end of the relay zone, however, as in the Figures 3, flexibility is achieved in addition to maintaining the time aligned attribute. Note that the ratio of DL/UL subframe is identical throughout the system. Figure 4 shows the example of the multi-hop frame structure with postamble, i.e. in Figure 4, the amble is placed at the end of each relay zone.

### 2.3 Case 3: Amble in the middle of the relay zone

Consider the case when the amble is placed somewhere in the middle of the relay zone, while satisfying the time aligned amble location. In this case, as shown in Figure 5, the amble location is likely to constrain the resource allocation.

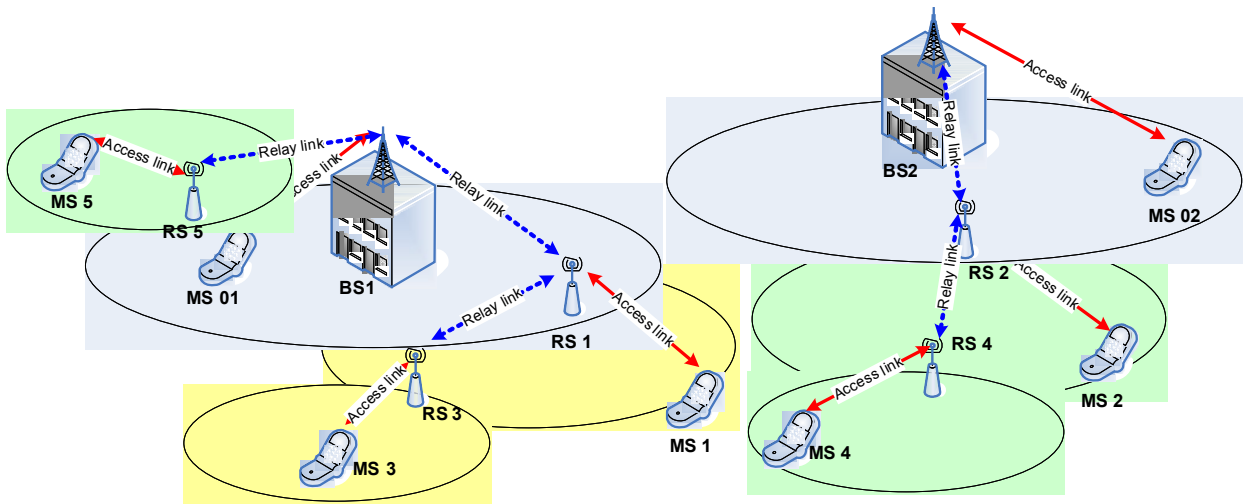

Figure 1. An example topology using Multi-hop Relay

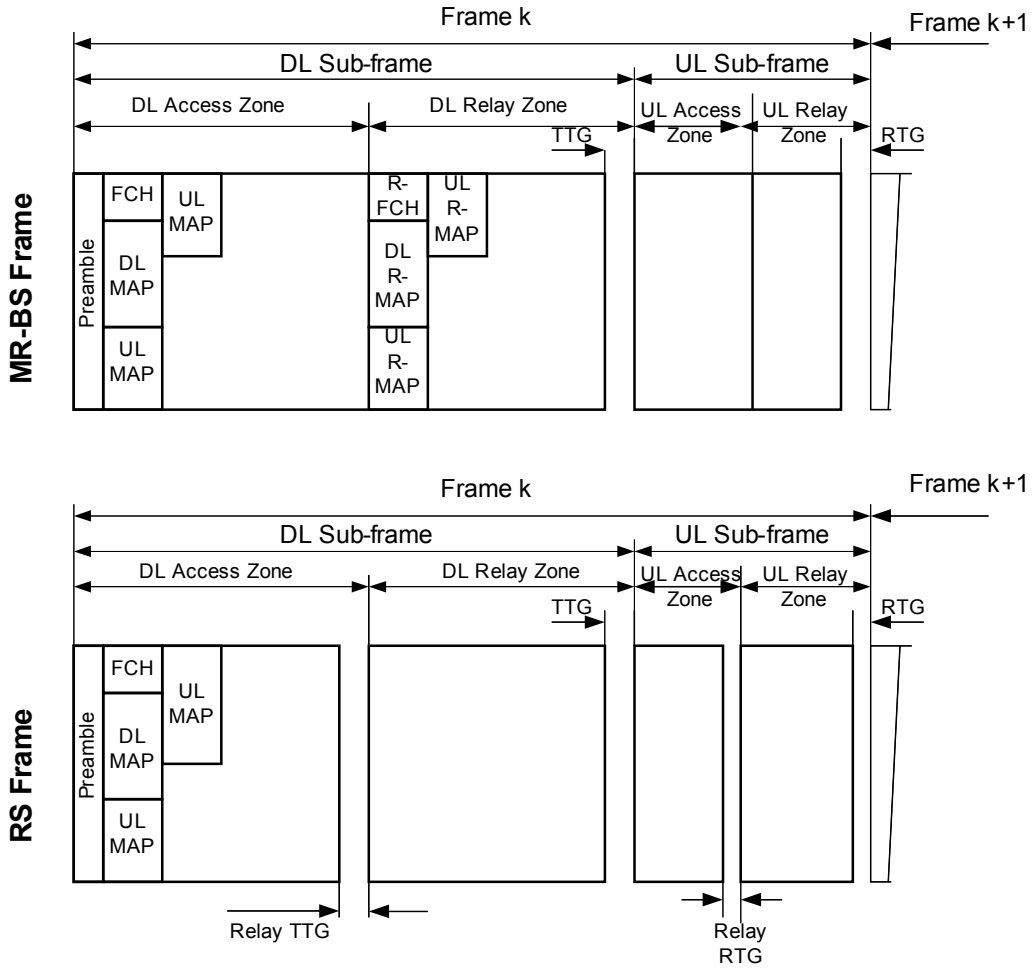

Figure 2. An example of a frame structure supporting multi-hop relay (adopted from [1]).

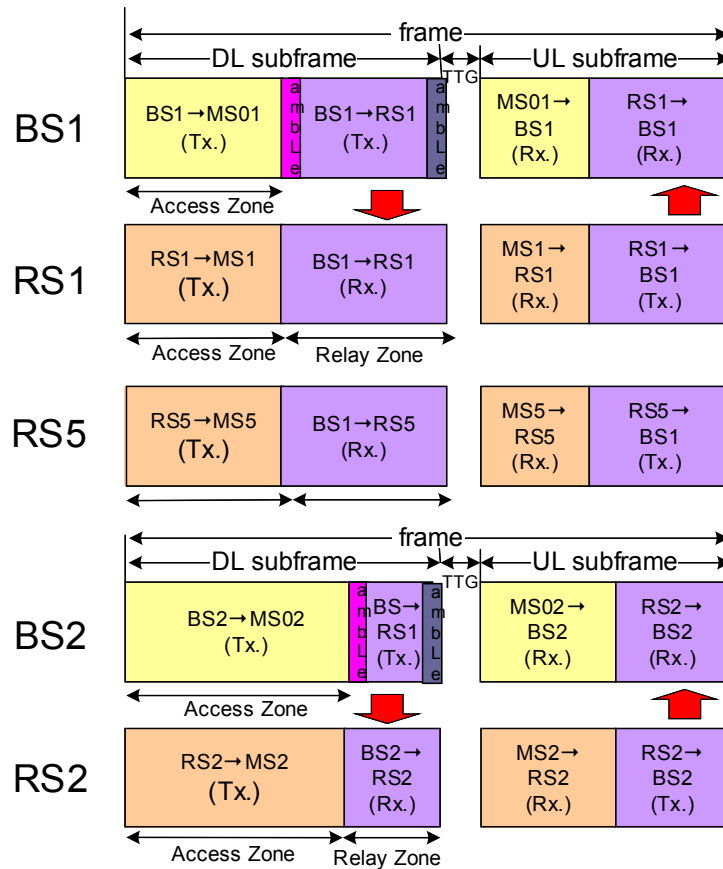

Figure 3. Postamble vs. Preamble. Using the postamble it is possible to maintain time alignment while allowing flexibility in the zone boundary. When amble is located at the start of the frame, however (i.e. preamble), time alignment attribute is lost when choosing for zone boundary flexibility.

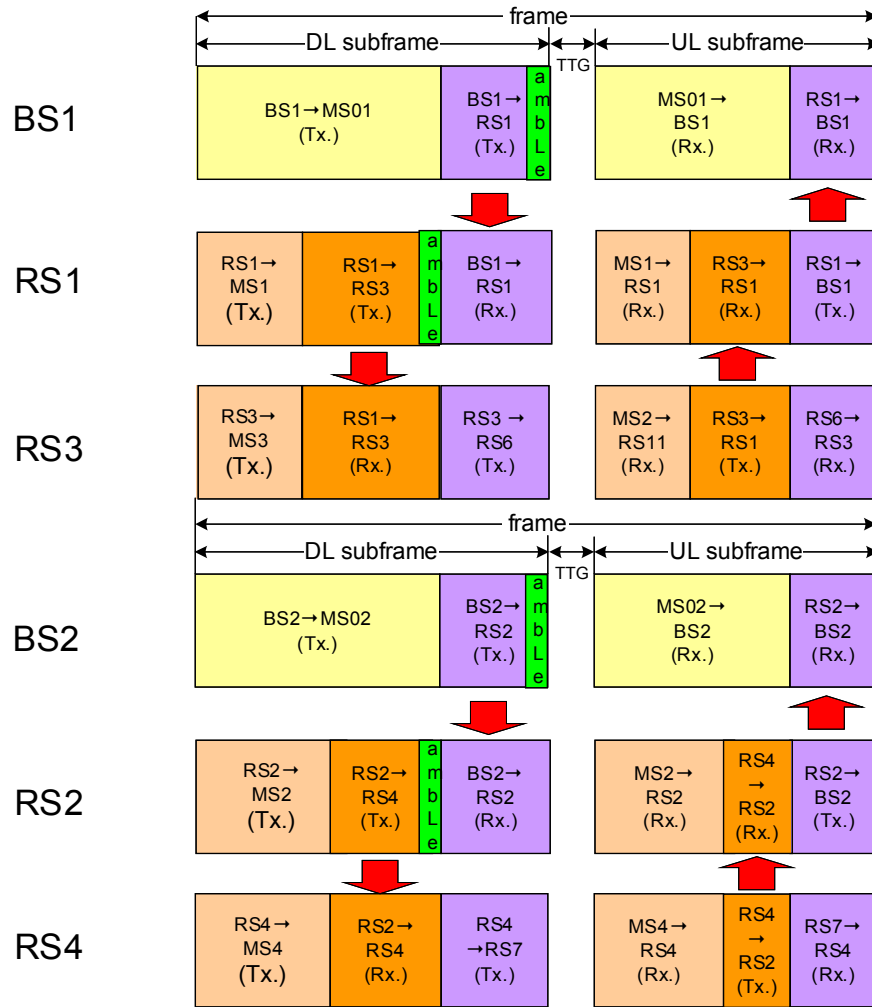

Figure 4 Time aligned amble location at the end of each relay zone for multi-hop relay.

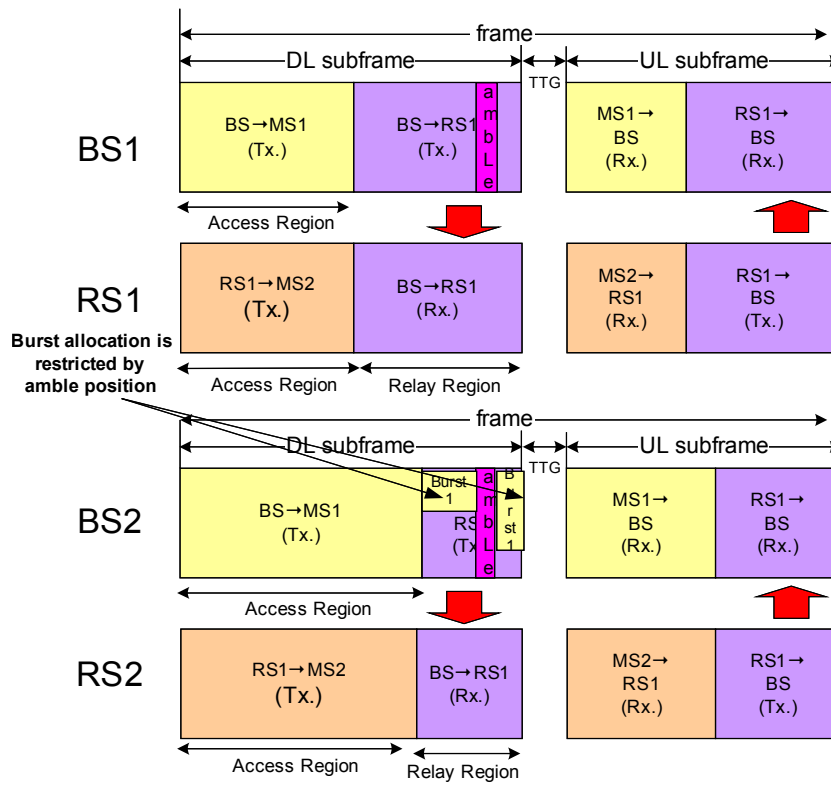

Figure 5 Time aligned amble location in the middle of the relay zone

### 5. Proposed Text

+++++++ start text proposal ++++++

[Insert a new sentence at the end of subclause 8.4.4.7.2.2:]

The relay link amble, when present, shall be located at the end of the last DL relay zone in which MR-BS/RS is in transmit mode.

[Replace the Figure xx at subclause 8.4.4.7.2.1:]

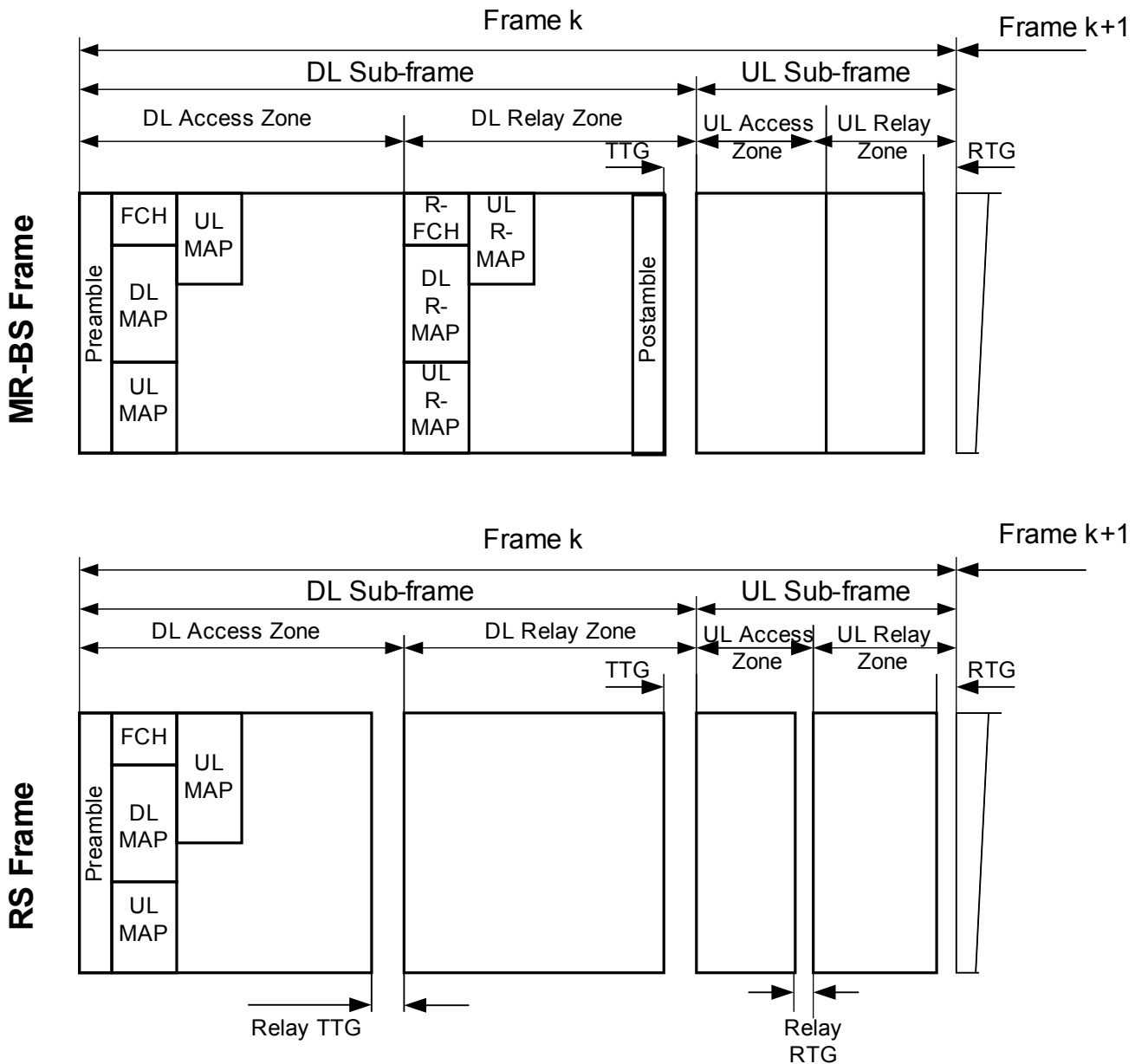

Figure xx Example of minimum configuration for an in-band non-transparent frame structure

+++++++ End of text proposal ++++++



## References

- [1] IEEE 802.16j-06/298r2, "Minimum guideline for harmonized frame structure", Nov. 2006
- [2] IEEE 802.16j-06/233r8, "Frame Structure to support relay node operation", Nov. 2006